

part #	description	qty	price
--------	-------------	-----	-------

1:10 ON ROAD NITRO DUAL SPORT CATALOG

CATALOG #10NDS June 1997

This free catalog is updated yearly; is yours current?
If you cannot obtain parts from your distributor or dealer, you may order them directly from us.

(We're sorry, you cannot order car kits from us.)

Numbers in **boldface** are unique to this catalog.

ORDERING INSTRUCTIONS

1. Write out order on separate sheet of paper if Order Form is missing. Include part no., quantity, and price of each item. **Include your phone no., full name and return address. DO NOT SEND CASH. NO CREDIT CARD ORDERS ACCEPTED.**

2. **California residents only** add sales tax: 7.75% in Orange County, 6.25% elsewhere.

3. **Add shipping fee of \$4.25** to all orders, except for faster Red, Orange & Blue Label services and international orders, which require extra charges.

4. **C.O.D. fee is \$4.75** (C.O.D. = "Cash On Delivery")

5. All international orders must be prepaid by International Money Order in US funds.

6. Mail order to: **Associated Electrics, Inc.**
3585 Cadillac Ave.
Costa Mesa, CA 92626 USA

7. Or call (714) 850-9342. **Please have your order ready before calling.** Or FAX: 714-850-1744. **Include your phone no., full name and return address.**

RC10 NITRO DS SPORT KITS

See page 2 for more details of all RC10NDS kits

part #	description	qty	price
8070	RC10 Nitro DS SPORT KIT Complete bushing kit w/muffler for pull start engine. Requires the addition of a .12 pull start engine and radio system to complete.	1	285.00
8071	RC10 Nitro DS SPORT KIT Complete bushing kit w/muffler for pull start engine. Requires a .12 pull start engine and radio system to complete.	1	285.00
8072	RC10 Nitro DS SPORT KIT Complete bushing kit w/muffler for pull start engine. Requires a .12 pull start engine and radio system to complete.	1	285.00

RC10 NITRO DS COMPETITION KITS

part #	description	qty	price
8075	RC10 Nitro DS RACER KIT, ball bearing kit without body. With tuned pipe for pull start engine. Uses same bodies as RC10DS. Requires a .12 pull start engine and radio system to complete.	1	410.00
8076	RC10 Nitro DS RACER KIT, ball bearing kit without body. With tuned pipe for non-pull start engine. Uses same bodies as RC10DS. Requires a .12 non-pull start engine and radio system to complete.	1	410.00

CLEAR BODIES & ACCESSORIES

part #	description	qty	price
--------	-------------	-----	-------

711	REEDY CAR WASH. Great for cleaning gas and electric cars and bodies. Lexan safe and biodegradable. Not for electrical components. 4 oz. bottles sold in cases of 12 only. Price reflects \$6.00 per bottle. (Purchase individual bottles at your hobby shop or race track.)	12	72.00
6180	DRIVER, clear	1	2.00
6190	WING MOUNT, adjustable (Wing-Things)	pr	1.75
6193	ALUMINUM WING MOUNT. Fits .065" and .078" wire	pr	3.50

DECALS

717	REEDY MODIFIED DECALS, 1995 style Reedy Logo, 3 sizes in both black and white (5.5" x 8.5" sheet)	1	2.50
718	REEDY MODIFIED DECALS, 1995 style Reedy Logo, 3 sizes in both fluorescent red and green (5.5" x 8.5" sheet)	1	3.50
2812	LARGE TEAM ASSOCIATED DECAL, black	5	2.50
2813	LARGE TEAM ASSOCIATED DECAL, white	5	2.50
3807	"RC10" DECALS, 3 sizes, fluorescent red & yellow	1	2.00
3817	ASSOCIATED BUMPER STICKERS, 1 large, 1 small. Red, white, blue.	1	4.00
3818	TEAM ASSOCIATED LOGO DECALS, Mylar peel and stick, black	6	1.00
3819	TEAM ASSOCIATED LOGO DECALS, Mylar peel and stick, white	6	1.00
6196	TEAM ASSOCIATED & MISC. SPONSORS decals, 5 colors	1	2.00
8801	"RC10DS" LOGO DECAL SHEET. Several sizes included. Fluorescent red and yellow with black outlines.	1	2.00

FRONT SUSPENSION & LINKAGE

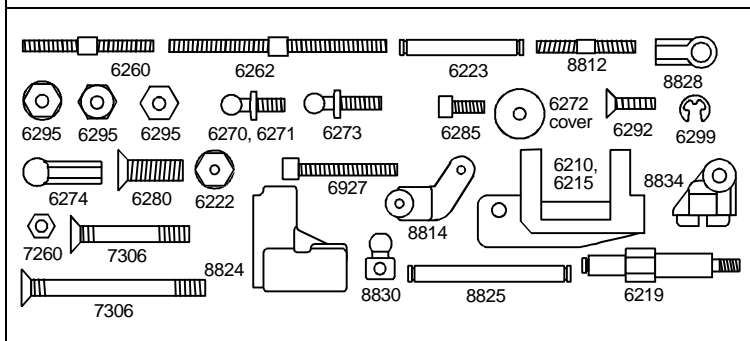

part #	description	qty	price
--------	-------------	-----	-------

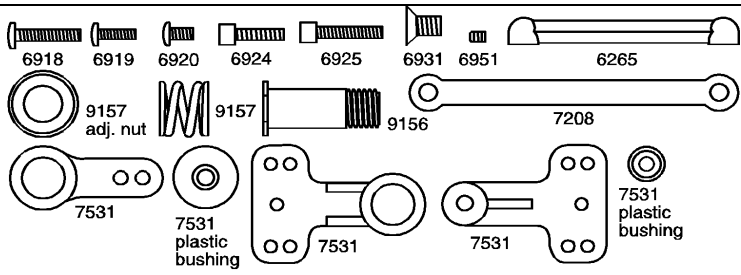
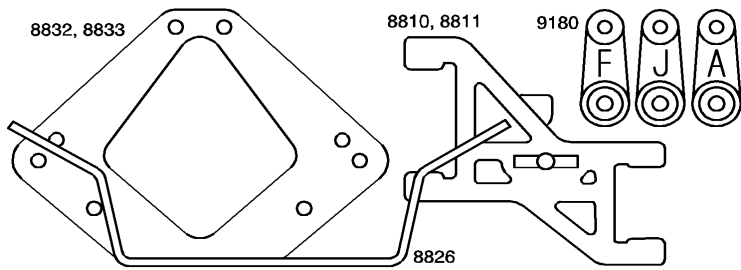

6210	FRONT BLOCK CARRIER, 30° caster	pr	3.00
6215	FRONT BLOCK CARRIER, 25° caster	pr	4.50
6219	FRONT STUB AXLE, steel 4-40 thread (w/E-clips and nuts)	pr	5.00
6222	SELF-THREADING NYLON LOCKNUT, for #6220 axles (Fits 4-40 or 5-40 thread)	8	2.00
6223	KINGPIN, with clips	pr	2.50
6260	TURNBUCKLE, 1"	2	3.00
6262	TURNBUCKLE, 1.65"	2	3.00
6265	DRAG LINK. One-piece replacement of the standard ball cups-and-turnstile linkage.	1	2.00
6270	BALL END, short thread, w/plastic end caps & nuts	2	2.50
6271	BALL END, short thread, w/plastic end caps & nuts	12	10.00
6272	BALL CUP DUST COVER	28	2.00
6273	BALL END, long thread, w/plastic end caps & nuts. 1/10" longer thread than #6270	2	2.50
6274	BALL CUP, spares for 6270, 6271, & 6273. molded nylon	14	5.00
6280	FLAT HEAD MACHINE Screw, (aluminum) 8-32 x 1/2"	16	2.00
6285	SOCKET HEAD CAP Screw, 4-40 x 1/4"	12	2.00
6292	FLAT HEAD SOCKET Screw, 4-40 x 3/8"	6	2.00
6295	4-40 NUT, 6 each plain nut, nylon and steel locknut	18	2.00
6299	E-CLIP, for 1/8 shaft	12	1.00
6918	BUTTON HEAD SOCKET Screw, 4-40 x 1/2"	6	2.00
6919	BUTTON HEAD SOCKET Screw, 4-40 x 5/16"	6	2.00
6920	BUTTON HEAD SOCKET Screw, 4-40 x 3/16"	6	2.00
6924	SOCKET HEAD CAP Screw, 4-40 x 3/8"	6	2.00
6925	SOCKET HEAD CAP Screw, 4-40 x 1/2"	6	2.00
6927	SOCKET HEAD CAP Screw, 4-40 x 3/4"	6	2.00
6931	FLAT HEAD MACHINE Screw, 8-32 x 1/4"	6	1.00
6951	SOCKET HEAD SET SCREW, 4-40 x 1/8", w/wrench	6	2.50
7208	FRONT BULKHEAD SUPPORT, aluminum	1	1.50
7260	4-40 NUT, plain small pattern	12	2.00
7306	NOSE PLATE SCREW SET (servo saver mounting screws)	1	2.00
7531	SERVO SAVER, plastic parts	set	2.50
8810	DS FRONT A-ARM, molded composite	pr	5.00
8811	DS FRONT A-ARMS, graphite composite. Optional	pr	8.00
8812	DS FRONT/REAR UPPER TURNBUCKLE, 0.75"	pr	3.00
8814	FRONT STEERING BLOCK trailing axle design for use with #6219 front axle. (Std. On Nitro DS kit)	pr	2.00
8824	DS FRONT BULKHEAD	1	4.00
8825	DS FRONT INNER HINGE PIN	pr	3.00
8826	DS FRONT ANTI-ROLL BAR KIT	1	8.00
8828	DS ROLL BAR CUPS, molded	2pr	2.00
8830	DS ROLL BAR PIVOT, aluminum, with set screw	2	4.00

part #	description	qty	price
--------	-------------	-----	-------

8832	DS FRONT SHOCK STRUT, fiberglass	1	7.00
8833	DS FRONT SHOCK STRUT, graphite	1	12.00
8834	DS FRONT ARM/SHOCK MOUNT	pr	1.50
9156	SERVO SAVER HUB, threaded	1	2.50
9157	SERVO SAVER SPRING & ADJUSTING NUT	1	2.00
9180	SERVO HORNS, molded (1 ea. fits Airtronics, Futaba, or JRpropo)	1	2.50

CHASSIS PARTS

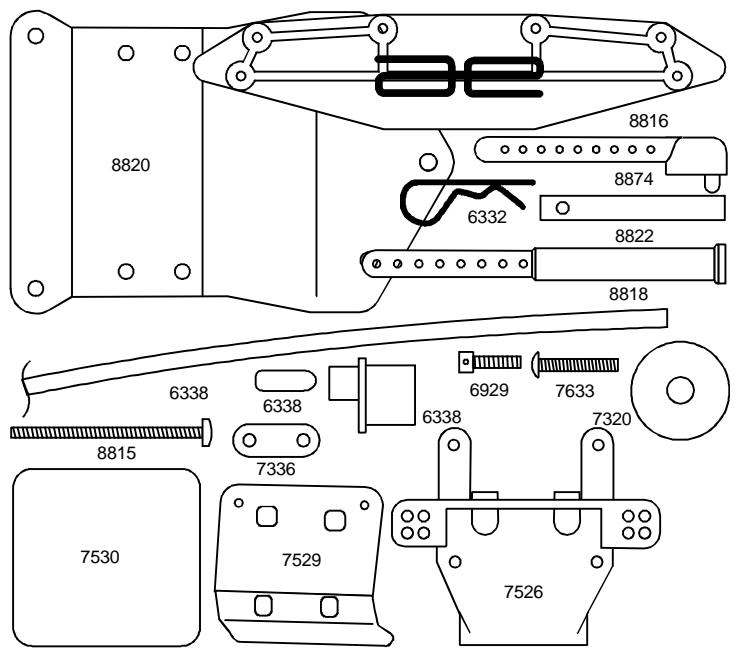

6285	SOCKET HEAD Cap screw, 4-40 x 1/4", steel	12	2.00
6312	CLEAR CHASSIS PROTECTIVE SHEET to protect the chassis finish, 6 1/2" x 18"	1	9.00
6332	HOOD PIN	6	.75
6338	ANTENNA KIT, with hardware	1	2.00
6917	BUTTON HEAD Cap screw, 4-40 x 3/8"	6	2.00
6924	SOCKET HEAD Cap screw, 4-40 x 3/8"	6	2.00
6925	SOCKET HEAD Cap screw, 4-40 x 1/2"	6	2.00
6927	SOCKET HEAD Cap screw, 4-40 x 3/4"	6	2.00
6932	SOCKET HEAD Cap screw, 4-40 x 5/16"	6	2.00
6936	#4 FLAT WASHER, aluminum	10	1.00
7260	4-40 NUT, plain small pattern	12	2.00
7306	NOSE PLATE SCREW SET (servo saver mounting screws)	1	2.00
7320	BODY MOUNT LARGE NYLON WASHER	4	.75
7336	SERVO MOUNT KIT, plastic parts, spacers and hardware	set	2.50
7337	SERVO MOUNT WASHERS, steel	4	1.00
7526	REAR BULKHEAD, new updated design, fits Nitro Ds and RC10GT	1	3.00
7527	SERVO MOUNTS, gas truck	2pr	2.50
7528	ANTENNA/RECEIVER MOUNT	1	2.00
7529	REAR BUMPER, gas truck	1	3.50
7530	FOAM PAD, for mounting receiver battery pack	1	1.50
7633	BUTTON HEAD SOCKET Screw, 4-40 x 5/8"	6	2.00
8815	NITRO DS CHASSIS, black anodized aluminum	1	36.00
8816	DS FRONT BUMPER	1	4.00
8818	DS FRONT BODY POST	pr	3.50
8820	DS FRONT KICKUP, aluminum, black anodized	1	8.00
8822	DS FRONT NOSE BRACE TUBE	pr	4.00
8874	DS REAR BODY MOUNT	pr	3.50

REAR SUSPENSION

(*) denotes non-standard discount item. (**) denotes short discount or net item.

part #	description	qty	price
--------	-------------	-----	-------

part #	description	qty	price
--------	-------------	-----	-------

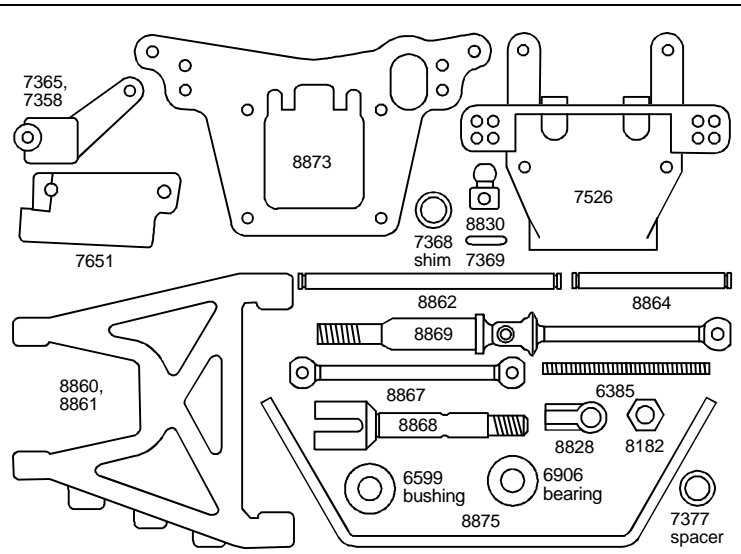

8860	DS REAR A-ARM, molded composite	pr	6.00
8861	DS REAR A-ARM, graphite. Optional	pr	9.00
8862	DS REAR INNER HINGE PIN	pr	3.00
8864	DS REAR OUTER HINGE PIN	pr	3.00
8867	DS DOGBONE	ea	5.00
8868	DS REAR STUB AXLE	ea	5.00
8869	DS UNIVERSALS	pr	35.00
8873	NITRO DS REAR SHOCK STRUT, fiberglass	1	6.50
7377	REAR AXLE BEARING SPACER, aluminum. For 3/16" rear axles	2	1.50
8828	DS ROLL BAR CUP	2pr	2.00
8830	DS ROLL BAR PIVOT, aluminum, with set screw	2	4.00
8875	DS REAR ANTI-ROLL BAR KIT	1	7.50
7651	REAR SUSPENSION MOUNTS, gas truck, 3 deg. toe-in per side	pr	2.00
7658	FLAT HEAD MACHINE Screw, 8-32 x 3/8", black anodized	6	2.00
6295	4-40 NUTS, 6 each, plain nut, nylon & steel locknuts	18	2.00
6296	8-32 LOCKNUTS, 6 each, Alum. Locknuts, nylon locknuts	12	3.00
6906	BALL BEARING, unflanged. 3/16" x 3/8"	pr	13.00
6917	BUTTON HEAD SOCKET Screw, 4-40 x 3/8"	6	2.00
6925	SOCKET HEAD CAP Screw, 4-40 x 1/2"	6	2.00
6927	SOCKET HEAD CAP Screw, 4-40 x 3/4"	6	2.00
6936	#4 FLAT WASHER, aluminum	10	1.00
7365	REAR HUB CARRIER, 0° toe-in per side (uses 1/4 X 3/8 unflanged bearing #7359)	pr	3.50
7358	REAR HUB CARRIER, 3° toe-in per side (uses 1/4 X 3/8 unflanged bearing #7359)	pr	3.50
7526	REAR BULKHEAD, fits GT and Nitro DS	1	3.00
6385	4-40 X 1 1/4 threaded rod (upper link)	2	1.00
7368	UNIVERSAL SHIMS, 3/16" I.D.	14	1.50
7369	AXLE SPRING PINS, 1.16"	4	1.00
6599	BUSHING, unflanged, 3/16 x 3/8"	4	2.00
6906	BALL BEARING, unflanged, 3/16" x 3/8"	pr	13.00
8182	8-32 NUT, special plain nut, used for rear suspension mount	6	2.00

TRANSMISSION

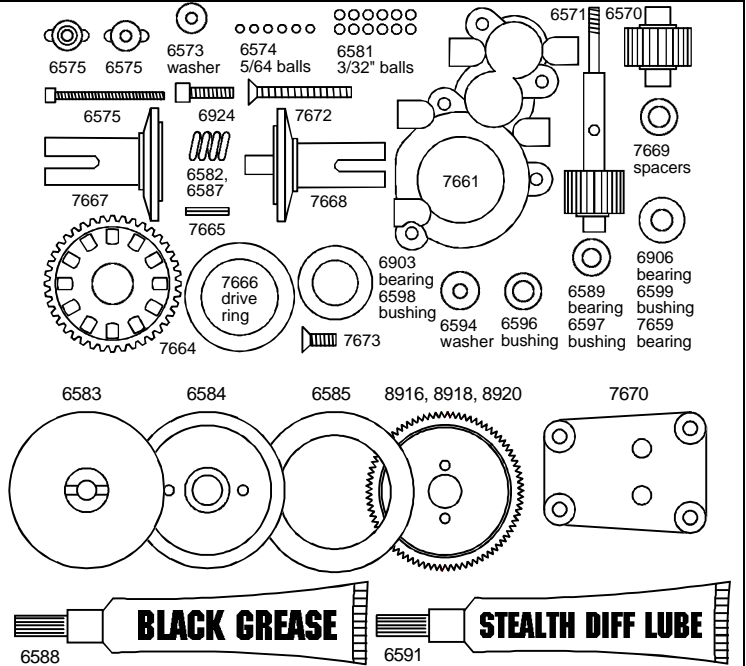

6563	COMPLETE TRANNY BALL BEARING SET (eight bearings and one busing)	set	52.00
7659	ECONOMY BEARINGS, to support gas truck idler gear in sport truck models	2	7.50
7661	GT TRANSMISSION CASE, left & right sides, for 2.60:1 transmission	set	6.00
6568	SPUR GEAR SCREW, 4-40 x 3/16"	4	1.50
6570	IDLER SHAFT AND GEAR	set	3.50
6571	DRIVE GEAR/SHAFT Assembly, w/roll pin	set	9.00
7665	GT DRIVE SHAFT ROLL PIN 3/32" x 7/16"	6	1.00
7669	DRIVE SHAFT SPACER	6	2.00
6573	DIFF THRUST WASHER	2	3.00
6574	PRECISION THRUST BALL, 5/64" (Replaces #6576)	6	2.00
6575	DIFF THRUST BOLT, THRUST BEARING COVER, dogbone spacers & Locking T-nut	1	2.00
7667	DIFF OUTDRIVE HUB, right, 2.60:1, fits T2, GT, Nitro DS	1	7.50
7668	DIFF OUTDRIVE HUB, left, 2.60:1, fits T2, GT, Nitro DS	1	7.50
7666	DIFF DRIVE RING, 2.60:1, Fits T2, GT, Nitro DS	2	1.50
7664	DIFF GEAR, 2.60:1, Fits T2, GT, Nitro DS	1	2.50
7670	TRANSMISSION BRACE, fits GT & Nitro DS	1	2.00
6581	CARBIDE DIFF BALL, large, 3/32"	12	12.00
6582	DIFF THRUST SPRING	1	1.50
6583	TORQUE CONTROL HUB, inner	1	7.50
6584	TORQUE CONTROL HUB, outer	1	7.50
6585	CLUTCH DISK	1	3.00
6594	THRUST BEARING WASHER, replaces #6586 thrust bearing	set	2.00
6587	TORQUE CONTROL SPRING & NUT	1	1.50
8916	56 TOOTH 32 PITCH SPUR GEAR	1	4.00
8918	58 TOOTH 32 PITCH SPUR GEAR	1	4.00
8920	60 TOOTH 32 PITCH SPUR GEAR	1	4.00
6588	BLACK GREASE	1	2.50
6589	DIFF BEARING, 5/32 X 5/16 unflanged	2	13.00
6591	TRANNY DIFF LUBE	1	2.50
6592	ALLEN WRENCH SET, 1/16", 5/64", 3/32"	1	2.50
6901	BALL BEARING, unflanged, 3/16 "x 5/16"	pr	13.00
6903	BALL BEARING, unflanged PTFE sealed 3/8" x 5/8"	2	20.00

part #	description	qty	price
--------	-------------	-----	-------

6906	BALL BEARING, unflanged, 3/16" x 3/8 "	2	13.00
6595	COMPLETE BUSHING SET FOR ASSOC. TRANSMISSION	9	5.00
6596	BUSHING, unflanged, 3/16" x 5/16"	2	1.00
6597	BUSHING, unflanged, 5/32" x 5/16"	2	1.00
6598	BUSHING, unflanged, 3/8" x 5/8"	2	1.50
6599	BUSHING, unflanged, 3/16" x 3/8"	4	2.00

BRAKE/THROTTLE

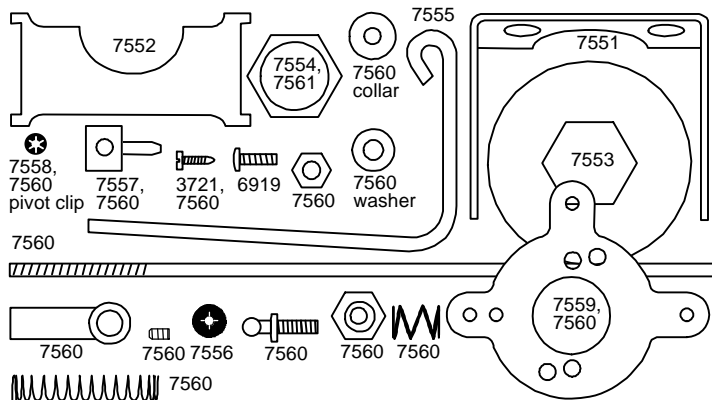

7551	BRAKE BRACKET, plated	1	2.50
7552	BRAKE SHOE, plated	1	1.50
7553	BRAKE DISC, fiber	1	4.00
7554	DISC BRAKE ADAPTER, plastic	1	1.00
7555	DISC BRAKE CAM,, steel	1	3.00
7556	BRAKE CAM CLIP (push nut)	6	1.50
7557	THROTTLE PIVOT, aluminum	1	2.00
7558	THROTTLE PIVOT CLIP (push nut)	6	1.50
7559	SERVO HORN ADAPTER, plastic	1	1.50
7560	BRAKE/THROTTLE LINKAGE KIT, complete	1	9.00
7561	DISK BRAKE ADAPTER, aluminum	1	3.50
3721	SELF-TAPPING screw, #2 X 1/4"	12	1.00
6919	BUTTON HEAD SOCKET Screw, 4-40 x 5/16"	6	2.00

SHOCKS

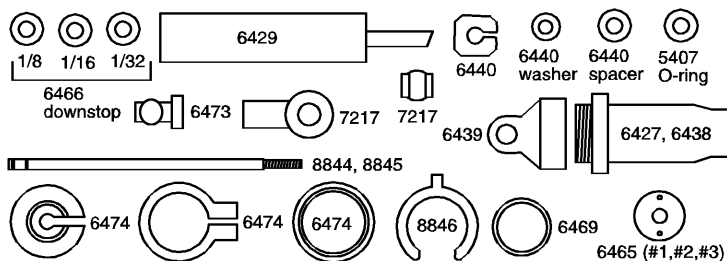

GOLD. Associated's standard shocks (#8840 & 8842) are precision machined to very close tolerances.

8840	DS FRONT SHOCK KIT, gold	1	25.00
8842	DS REAR SHOCK KIT, gold	1	25.00
6427	BODY, front, .056 STANDARD	1	6.75
6428	END CAP, plastic	1	2.25

GRAY. Associated's racing shocks (#8839-8841) are hard anodized and PTFE coated precision machined shock bodies for long wear and superior performance.

8839	DS FRONT SHOCK KIT, hard anodized	1	30.00
8841	DS REAR SHOCK KIT, hard anodized	1	30.00
6438	BODY, .56 RACING	1	7.75
6439	END CAP FOR GRAY SHOCKS, aluminum	1	3.00

PARTS FOR ALL SHOCKS

6429	SHOCK ASSEMBLY TOOL	1	1.00
6440	REBUILD KIT for Standard and Racing shocks, for 4	set	4.00

part #	description	qty	price
--------	-------------	-----	-------

shocks			
8844	DS SHOCK SHAFT, .35" stroke	ea	3.00
8845	DS UNOBTAINIUM SHOCK SHAFT, .35" stroke	ea	6.00
8846	DS SHOCK PRE-LOAD SPACERS, four sizes	set	3.00
7217	SHOCK ROD END, nylon w/plastic pivot ball	2	3.00
6464	PISTON, all 0.4 bore shocks	4	3.00
6465	PTFE SHOCK PISTON, 4 each of #1, #2 & #3. To adjust dampening.	12	3.00
6466	SHOCK DOWNSTOP	6	1.50
5407	RED O-RING, replacements for shock rebuild kits #6440 and #6467	8	2.00
6469	O-RING, shock end-cap to body seals	4	1.50
6473	SHOCK BUSHING	4	1.00
6474	SPRING CLAMP AND CUP, 4 sets	4	3.00

PRECISION RACING SPRINGS



6494,
6496,
8232

6496	Silver, 1.4"	2	2.50
8232	Black, 1.4"	2	2.50
6494	Green, 1.4"	2	2.50

SHOCK OILS

5412	SHOCK OIL, 50 wt, 1 oz bottle	1	1.25
5413	SHOCK OIL, 40 wt, 1 oz bottle	1	1.25
5414	SHOCK OIL, 30 wt, 1 oz bottle	1	1.25
5415	SHOCK OIL, 20 wt, 1 oz bottle	1	1.25
5416	SHOCK OIL, 10 wt, 1 oz bottle	1	1.25
5420	SILICONE SHOCK OIL, 10 wt, 2 oz bottle	1	3.50
5427	SILICONE SHOCK OIL, 15 wt, 2 oz bottle	1	3.50
5421	SILICONE SHOCK OIL, 20 wt, 2 oz bottle	1	3.50
5428	SILICONE SHOCK OIL, 25 wt, 2 oz bottle	1	3.50
5422	SILICONE SHOCK OIL, 30 wt, 2 oz bottle	1	3.50
5429	SILICONE SHOCK OIL, 35 wt, 2 oz bottle	1	3.50
5423	SILICONE SHOCK OIL, 40 wt, 2 oz bottle	1	3.50
5425	SILICONE SHOCK OIL, 80 wt, 2 oz bottle	1	3.50

WHEELS & TIRES

See Associated's full-color Pictorial Catalog for pictures of all our wheels and tires

ACCESSORIES & SPRAY

6859	TRACTION ACTION TIRE SPRAY. Increases traction and life of tire. 4 oz. bottles sold in cases of 12 only. Price reflects \$6.00 per bottle. (Purchase individual bottles at your hobby shop or race track.)	1 case	72.00
8877	DS HUB CAP, yellow. Incl. front and rear pairs	4	6.00
8878	DS HUB CAP, black . Incl. front and rear pairs	4	6.00
8879	DS HUB CAP, gold. Incl. front and rear pairs	4	6.00

FRONT WHEELS & TIRES

8889	DS FOAM TIRE INSERT, fits front and rear tires	4	3.00
8880	DS FRONT WHEEL, chrome	pr	6.00
8881	DS FRONT WHEEL, black	pr	5.00
8886	DS FRONT TIRE, G-compound rubber	pr	11.50
6599	BUSHING, 3/16 X 3/8	4	2.00
6906	BALL BEARING, unflanged, 3/16" x 3/8"	pr	13.00

REAR WHEELS & TIRES

8889	DS FOAM TIRE INSERT, fits front and rear tires	4	3.00
8890	DS REAR WHEEL, chrome	pr	6.00
8891	DS REAR WHEEL, black	pr	5.00
8896	DS REAR TIRE, semi-pneumatic rubber, with foam inserts. Fits DS and Nitro DS wheels	pr	12.50

ENGINE MOUNT PARTS

part #	description	qty	price
--------	-------------	-----	-------

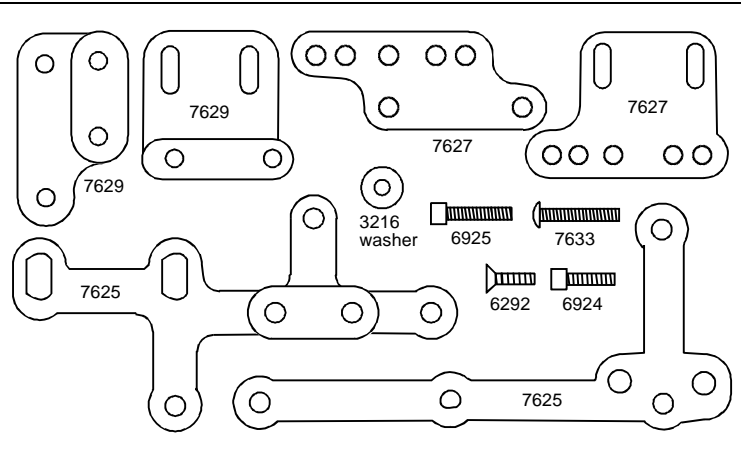

7625	CHASSIS ENGINE MOUNT, black	pr	8.00
7627	ENGINE MOUNT ADAPTER, for non-pull start engine	pr	11.00
7629	ENGINE MOUNT ADAPTER, for pull start engine	pr	8.00
3216	#4 FLAT WASHER, steel, (gold colored)	12	1.00
6292	FLAT HEAD SOCKET Screw, 4-40 x 3/8"	6	2.00
6924	SOCKET HEAD CAP Screw, 4-40 x 3/8"	6	2.00
6925	SOCKET HEAD CAP Screw, 4-40 x 1/2"	6	2.00
7633	BUTTON HEAD SOCKET Screw, 4-40 x 5/8" (rear engine mount adapter mounting screw)	6	2.00

CLUTCH

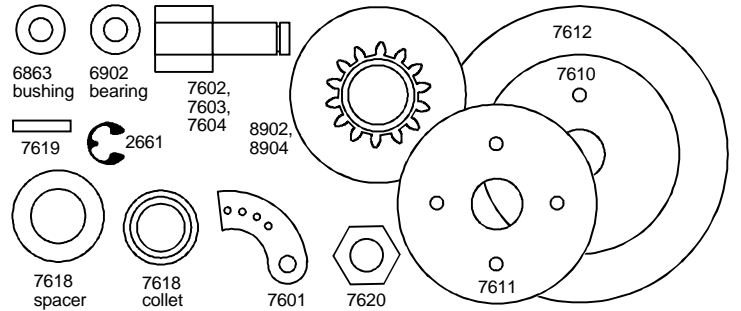

7601	CLUTCH SHOE, PTFE	pr	7.00
7602	CLUTCH NUT for Dynamite engine	1	5.00
7603	CLUTCH NUT (fits Yokomo and new OS Max engines)	1	5.00
7604	CLUTCH NUT, special (fits OS Max crankshafts made before Oct. 1993)	1	5.00
2661	CLUTCH NUT CLIPS	6	.75
8902	22 TOOTH, 32 PITCH CLUTCH BELL, steel.	1	8.50
8904	24 TOOTH, 32 PITCH CLUTCH BELL, steel.	1	8.50
6902	BALL BEARING, flanged 3/16" x 5/16"	pr	15.00
6863	BUSHING, flanged, 3/16" x 5/16"	4	1.50
7610	FLYWHEEL, non-pull start engine (Yokomo, Dynamite, OS Max)	1	8.00
7611	RACING FOUR SHOE FLY-WHEEL, requires two #7601 clutch shoe sets, not included	1	10.00
7612	FLYWHEEL, pull start engine (Yokomo, Dynamite, OS Max)	1	8.00
7618	FLYWHEEL COLLET, with spacer shim	1	3.00
7619	FLYWHEEL PIN	2	1.00
7620	SPECIAL CUT OFF NUT, for cutting crankshaft to correct length for clutch nut installation (Yokomo, Dynamite and OS Max)	1	2.50

ENGINE ACCESSORIES

part #	description	qty	price
--------	-------------	-----	-------

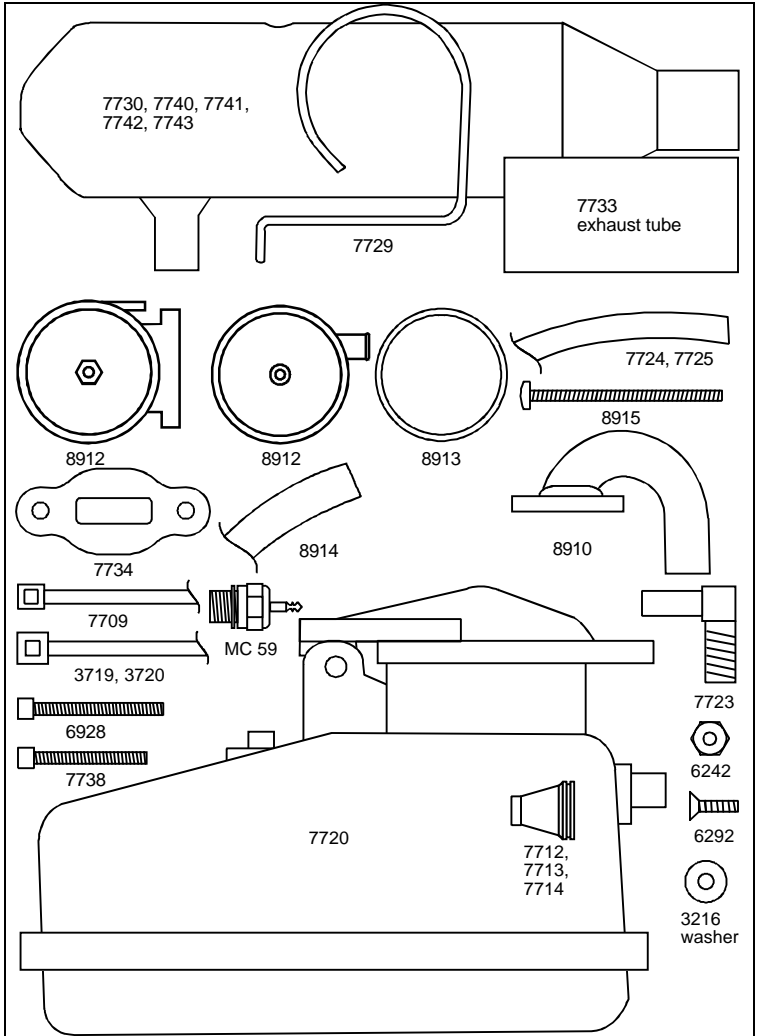

MC 59	McCOY GLOW PLUG. For .12 engines	1	3.65**
7705	AIR FILTER KIT, consists of paper filter, foam prefilter, and air filter boot	1	7.50
7706	PAPER AIR FILTER ELEMENT	1	3.00
7707	FOAM PREFILTER ELEMENT	4	2.50
7708	AIR FILTER BOOT	1	3.00
7710	FOAM FILTER TREATMENT	1 oz.	2.50
7712	CARBURETOR RESTRICTOR for the OS Max engine is designed to make your car easier to drive with smoother acceleration, .190", silver	1	3.50
7713	CARBURETOR RESTRICTOR, .180", blue	1	3.50
7714	CARBURETOR RESTRICTOR, .170", black	1	3.50
3719	NYLON WIRE TIES, 6" heavy duty	12	2.00
3720	NYLON TIES, 8", light duty for receiver	12	2.00
7709	NYLON WIRE TIES, 4" light duty	12	1.25
7720	FUEL TANK, plastic, 75cc	1	14.00
7723	FUEL TANK FITTING	1	4.00
7724	FUEL TUBING, 15"	1	2.00
7725	FUEL TUBING, 3 feet	1	4.00
7729	MUFFLER BRACKET	1	3.00
7730	MUFFLER TUNED PIPE	1	21.00
7740	MUFFLER, TUNED PIPE, black anodized	1	37.00
7741	MUFFLER TUNED PIPE, polished (chrome look)	1	37.00
7742	MUFFLER, TUNED PIPE, blue anodized	1	37.00
7743	MUFFLER TUNED PIPE, purple anodized	1	37.00
7733	SILICONE EXHAUST TUBING, 2"	1	2.00
7734	GASKET, exhaust manifold	3	2.00
8910	TUNED PIPE EXHAUST MANIFOLD, for non-pull start engine. For Nitro DS	1	12.50
8912	SPORT MUFFLER, for pull start engines	1	12.00

(*) denotes non-standard discount item. (**) denotes short discount or net item.

part #	description	qty	price
--------	-------------	-----	-------

8913	SPORT MUFFLER O-RING	1	1.50
8914	SPORT MUFFLER STINGER TUBE, rubber tubing	1	1.50
8915	PHILLIPS HEAD MACHINE SCREW, 4-40 x 1 1/2" (to assemble sport muffler), w/nuts	2pr	1.50
3216	#4 FLAT WASHER, steel (gold colored)	12	1.00
6242	4-40 LOCKNUTS, steel	6	1.00
6292	FLAT HEAD SOCKET Screw, 4-40 x 3/8"	6	2.00
6928	SOCKET HEAD CAP Screw, 4-40 x 1" (for Yokomo exhaust manifold installation)	6	2.00
7738	SOCKET HEAD CAP Screw, 4-40 x 7/8" (for OS Max and Dynamite exhaust manifold installation)	2	1.00

BALL BEARINGS

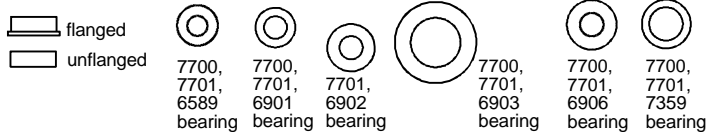

7700	BALL BEARING SET For all kits with 3/16" rear stub axles or universals. (Does not include gas engine clutch ball bearings #6902)	16	95.00
7701	COMPLETE BALL BEARING KIT, for RC10GT with 1/4" rear stub axles or universals (includes gas engine clutch ball bearings #6902)	18	105.00
6589	BALL BEARING, unflanged, 5/32" x 5/16"	pr	13.00
6901	BALL BEARING, unflanged, 3/16" x 5/16"	pr	13.00
6902	BALL BEARING, flanged, 3/16" x 5/16"	pr	15.00
6903	BALL BEARING, unflanged. 3/8" x 5/8"	pr	20.00
6906	BALL BEARING, unflanged, 3/16" x 3/8"	pr	13.00
7359	BALL BEARING, unflanged, 1/4" x 3/8"	pr	15.00

HARDWARE & TOOLS

MISCELLANEOUS HARDWARE

3721	SELF-TAPPING SCREW, #2 X 1/4"	12	1.00
6951	SOCKET SET SCREWS, 4-40 X 1/8", with wrench	6	2.50
6726	NEW IMPROVED SERVO TAPE, black roll, same adhesion, but easier to remove	36"	2.50
7709	NYLON WIRE TIES, 4 inch each	12	1.25
3719	NYLON WIRE TIE, 6" heavy duty	12	2.00
3720	NYLON WIRE TIE, 8" heavy duty	12	2.00
6270	BALL END, short thread, w/plastic end caps & nuts	2	2.50
6271	BALL END, short thread, w/plastic end caps & nuts	12	10.00
6272	BALL CUP DUST COVER	28	2.00
6273	BALL END, long thread, w/plastic end caps & nuts. 1/10" longer thread than #6270	2	2.50
6299	E-CLIPS for 1/8" shafts	12	1.00

NUTS

3438	8-32 LOCKNUT, aluminum	3	1.50
4184	4-40 LOCKNUT, nylon	6	1.00
4185	8-32 LOCKNUT, nylon	6	1.00
4449	4-40 LOCKNUT, alum. small pattern, gold anodized,	5	2.50
6222	SELF-THREADING NYLON LOCKNUT, for #6220 axles (fits 4-40 and 5-40 threads)	8	2.00
6242	4-40 LOCKNUTS, steel	6	1.00
6295	4-40 NUT, 6 each plain nut, nylon and steel locknut	18	2.00
6296	8-32 NUT, 6 each aluminum and nylon locknuts	12	3.00
8182	8-32 NUT, special plain nut. Used for rear suspension mount	6	2.00
6937	4-40 LOCKNUT, aluminum, blue anodized	6	3.00
7260	4-40 NUT, plain small pattern	12	2.00

WASHERS

3216	#4 FLAT WASHER, steel	12	1.00
3323	#8 FLAT WASHER, aluminum thick	12	1.50
6936	#4 FLAT WASHER, aluminum	10	1.00

SCREWS

part #	description	qty	price
--------	-------------	-----	-------

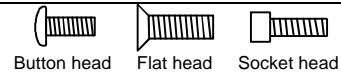

4334	BUTTON HEAD SOCKET Screw, 2-56 x 5/16"	8	1.50
6920	BUTTON HEAD SOCKET Screw, 4-40 x 3/16"	6	2.00
6288	BUTTON HEAD SOCKET Screw, 4-40 x 1/4"	6	2.00
6919	BUTTON HEAD SOCKET Screw, 4-40 x 5/16"	6	2.00
6917	BUTTON HEAD SOCKET Screw, 4-40 x 3/8"	6	2.00
6918	BUTTON HEAD SOCKET Screw, 4-40 x 1/2"	6	2.00
7633	BUTTON HEAD SOCKET Screw, 4-40 x 5/8"	6	2.00
6931	FLAT HEAD MACHINE Screw, 8-32 x 1/4"	6	1.00
6280	FLAT HEAD MACHINE Screw, 8-32 x 1/2", ALUM.	16	2.00
6281	FLAT HEAD MACHINE Screw, 8-32 x 7/8", ALUM.	6	2.00
3325	FLAT HEAD MACHINE Screw, 8-32 x 1 1/4", ALUM.	6	1.50
6291	FLAT HEAD SOCKET Screw, 4-40 x 1/4"	6	2.00
6939	FLAT HEAD SOCKET Screw, 4-40 x 1/4", ALUM.	6	2.00
7673	FLAT HEAD SOCKET Screw, 4-40 x 5/16"	6	2.00
6933	FLAT HEAD SOCKET Screw, 4-40 x 5/16", ALUM.	6	2.00
6292	FLAT HEAD SOCKET Screw, 4-40 x 3/8"	6	2.00
6934	FLAT HEAD SOCKET Screw, 4-40 x 3/8", ALUM.	6	2.00
6922	FLAT HEAD SOCKET Screw, 4-40 x 1/2"	6	2.00
6938	FLAT HEAD SOCKET Screw, 4-40 x 1/2" ALUM.	6	2.00
6923	FLAT HEAD SOCKET Screw, 4-40 x 3/4"	6	2.00
7672	FLAT HEAD SOCKET Screw, 4-40 x 7/8"	6	2.00
6285	SOCKET HEAD CAP Screw, 4-40 x 1/4"	12	2.00
6284	SOCKET HEAD CAP Screw, 4-40 x 1/4", ALUM.	12	4.00
6932	SOCKET HEAD CAP Screw, 4-40 x 5/16"	6	2.00
4145	SOCKET HEAD CAP Screw, 4-40 x 5/16" ALUM.	6	1.50
6924	SOCKET HEAD CAP Screw, 4-40 x 3/8"	6	2.00
6929	SOCKET HEAD CAP Screw, with hole, 4-40 x 3/8"	4	2.50
6860	SOCKET HEAD CAP Screw, 4-40 x 3/8" ALUM.	6	2.50
7874	SOCKET HEAD CAP Screw, 4-40 x 7/16"	8	2.50
7873	SOCKET HEAD CAP Screw, 4-40 x 7/16", ALUM.	8	2.50
6925	SOCKET HEAD CAP Screw, 4-40 x 1/2"	6	2.00
6916	SOCKET HEAD CAP Screw, with hole, 4-40 x 1/2"	4	2.00
6926	SOCKET HEAD CAP Screw, 4-40 x 5/8"	6	2.00
7801	SOCKET HEAD CAP Screw, 4-40 x 5/8", ALUM.	8	2.50
6927	SOCKET HEAD CAP screw, 4-40 x 3/4"	6	2.00
6928	SOCKET HEAD CAP Screw, 4-40 x 1"	6	2.00
6935	SOCKET HEAD CAP Screw, 4-40 x 1", ALUM.	4	3.00

TOOLS

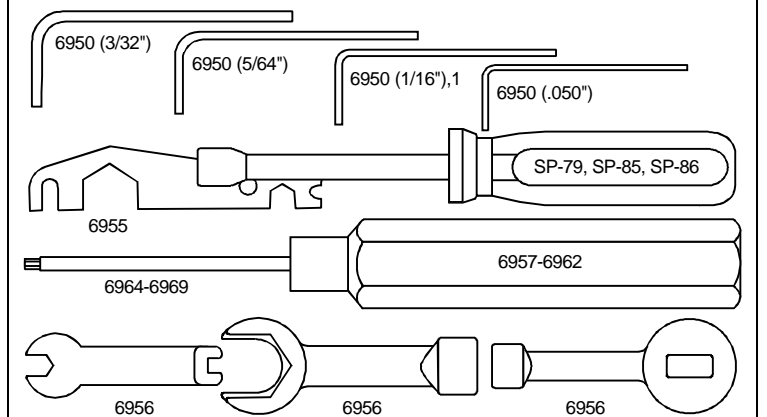

SP-79	NUT DRIVER, 3/8"	1	7.50*
SP-86	NUT DRIVER, 3/16"	1	7.50*
6950	ALLEN WRENCH set, 3/32", 5/64, 1/16, .050	4	2.50
6955	SHOCK/TURNBUCKLE WRENCH, original Associated tool (silver colored)	1	2.50
8416	SHOCK/TURNBUCKLE WRENCH, new Associated tool, fits Dynamic Strut Front End (gold colored)	1	2.50

part #	description	qty	price
--------	-------------	-----	-------

6956	ASSOCIATED MOLDED TOOL SET. Wrenches to install 11/32", 1/4" and 3/16" nuts, adjust 1/8" and 3/16" turnbuckles, and install and remove Associated shock caps.	Set	4.50
6957	.050" ALLEN DRIVER, precision ground replaceable tip, alum. hex handle (clear anodized)	1	10.50
6958	1/16" ALLEN DRIVER, precision ground replaceable tip, alum. hex handle (black anodized)	1	10.50
6959	5/32" ALLEN DRIVER, precision ground replaceable tip, alum. hex handle (blue anodized)	1	10.50
6960	3/32" ALLEN DRIVER, precision ground replaceable tip, alum. hex handle (gold anodized)	1	10.50
6961	2.5mm ALLEN DRIVER, precision ground replaceable tip, alum. hex handle (green anodized)	1	10.50
6962	1.5mm ALLEN DRIVER, precision ground replaceable tip, alum. hex handle (purple anodized)	1	10.50
6964	.050 REPLACEMENT TIP, precision ground	1	5.50
6965	1/16" REPLACEMENT TIP, precision ground	1	5.50
6966	5/64" REPLACEMENT TIP, precision ground	1	5.50
6967	3/32" REPLACEMENT TIP, precision ground	1	5.50
6968	2.5mm REPLACEMENT TIP, precision ground	1	5.50
6969	1.5mm REPLACEMENT TIP, precision ground	1	5.50

MISCELLANEOUS

See Associated's Pictorial Catalog for full-color pictures of all items below

CAR CARRIER EQUIPMENT

SP-100	ASSOCIATED CAR CARRIER BOX, cardboard outer box w/locking end flap, unassembled. Includes three 24 x 12 x 6" inner boxes, unassembled (fits inside #SP-415 carrier bag). <i>Due to its large size, an additional \$15.00 must be added to UPS standard shipping charges</i>	1	15.00**
SP-101	INNER BOXES, 24 x 12 x 6", unassembled. Replacement cardboard inner boxes for car carrier box #SP-100	3	5.25**
SP-415	ASSOCIATED CAR CARRIER BAG, black nylon with brass zipper (fits over #SP-100 car carrier box)	1	39.95**

APPAREL

SP-37	REEDY FIRE HAWK T-SHIRT. Fluorescent orange "Fire Hawk" and white Reedy logo on black T-shirt. Printed both sides. Specify M, L, XL only	1	11.00*
SP-37 XXL	REEDY FIRE HAWK T-SHIRT. Specify XXL.	1	13.00*
SP-39	RC10DS T-SHIRT, Full color of RC10DS cars. Same design both sides. Specify sizes M, L	1	11.00*
SP-410	TEAM ASSOCIATED JACKET, red, white & blue. Fully lined. Specify M, L, XL, XXL, XXXL.	1	59.95**

VIDEOS

6977	VHS VIDEO, "R/C Car Racing 1995"	1	19.95
6978	VHS VIDEO, "R/C Car Racing 1996"	1	19.95
6978P	PAL VIDEO, "R/C Car Racing 1996" Same as #6978, but in international PAL format.	1	19.95

part #	description	qty	price
--------	-------------	-----	-------