



MONSTER GT

BIGGER. FASTER. TOUGHER.

• Monster GT • Nitro Powered • Off Road Truck •

Monster GT 4.60 SE RTR Truck



Factory Team: blue extruded chassis



Factory Team: blue nuts



Factory Team: "Robo-Disc"



Factory Team: titanium turnbuckles

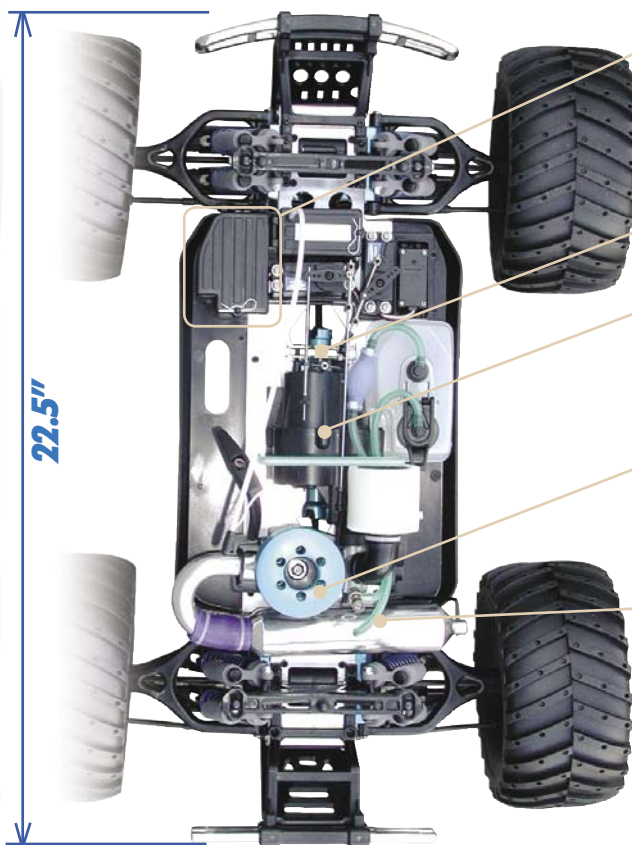

Features

- Sealed receiver box protects radio gear from dirt, dust and moisture. All radio gear easily removeable (with just four screws) for truck cleaning.
- Massive single-disc brake for positive, no-fade stopping power.
- 2-speed transmission equipped with tough steel gears and steel CVAs that are up to the job of handling the massive torque.
- AE 4.60 Engine with the unique MGT Dual-Start system: Convenient pull start or hex-shaft/drill start combined in one unit!
- High-performance tuned racing pipe with single outlet diverts exhaust out the bottom of the truck.
- Two painted body styles to choose from.

RTR = assembled

Preassembled with either of two painted body styles



Huge 6 5/8" diameter all-terrain tires



XP3 3-channel AM radio system—steering dual-rate, steering trim, throttle trim, high and low throttle end-point adjustments.



• SEE WEB SITE FOR COMPLETE DETAILS AND HOPUPS • www.RC10.com • www.TeamAssociated.com •

Page 10

FEATURE COMPARISONS

Feature	Monster GT SE RTR
transmission	2-speed reversible
shocks	8 oil-filled
tires	6 5/8" diameter
wheels	industry standard
turnbuckles	steel
bearings	shielded bearings
body	painted
dimensions	L=22.5", W=17.25"



#20501 Monster GT 4.60 SE RTR Truck \$839.99*

* Does not include foam prefilter treatment, fuel bottle, glow igniter, tools, batteries, fuel.