

B3 FRONT SUSPENSION

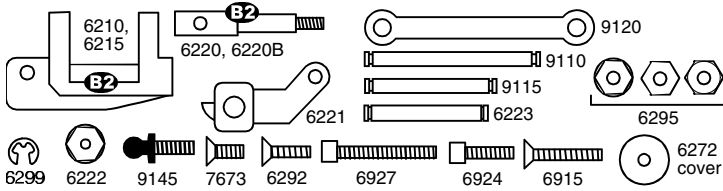

B3FRSUS2.WMF

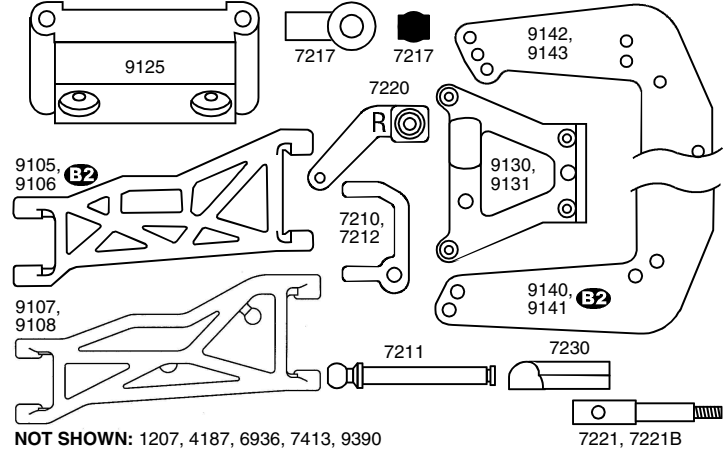

B3 REAR SUSPENSION

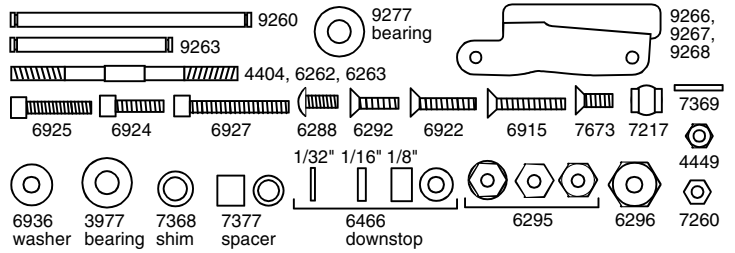

B3RRSUS2.WMF

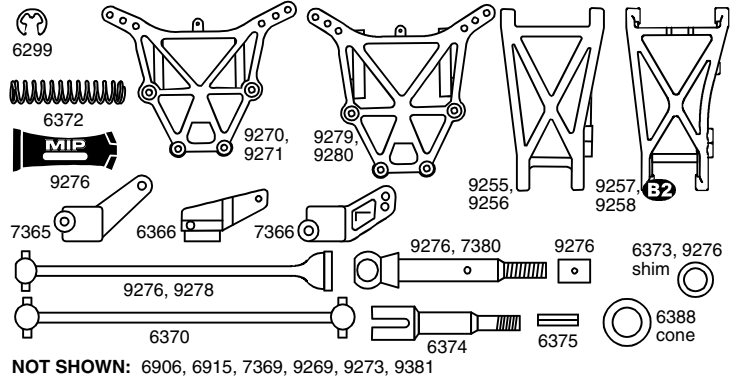

#9104 FRONT ANTI-ROLL BAR KIT



#9254 REAR ANTI-ROLL BAR KIT

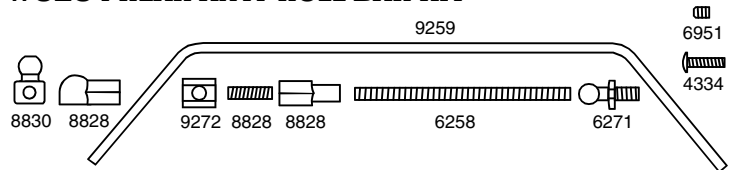

CHASSIS

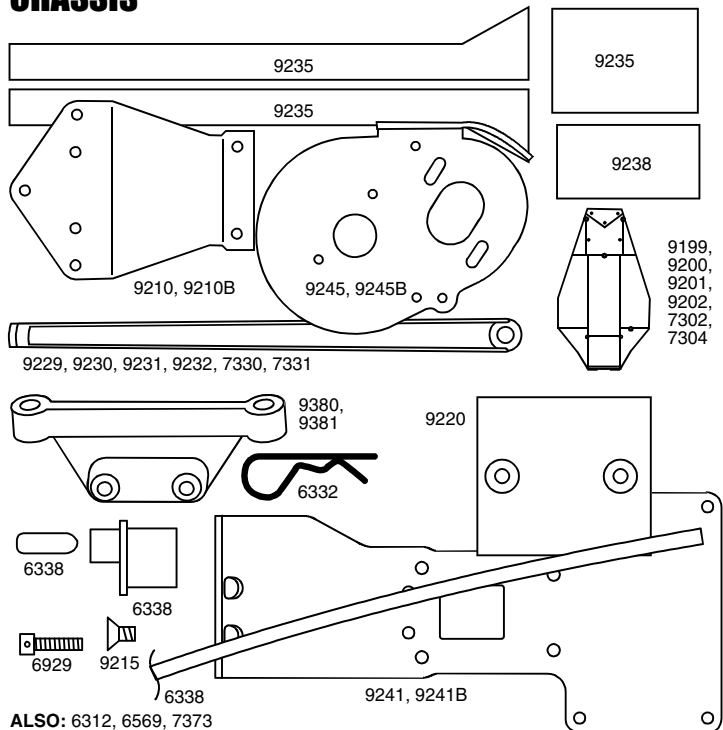

SHOCKS

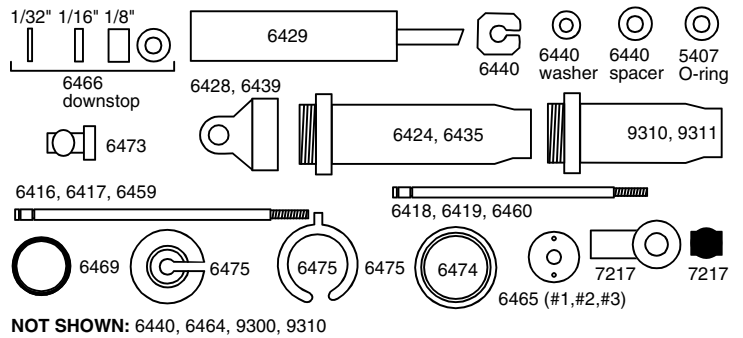

CHASSIS

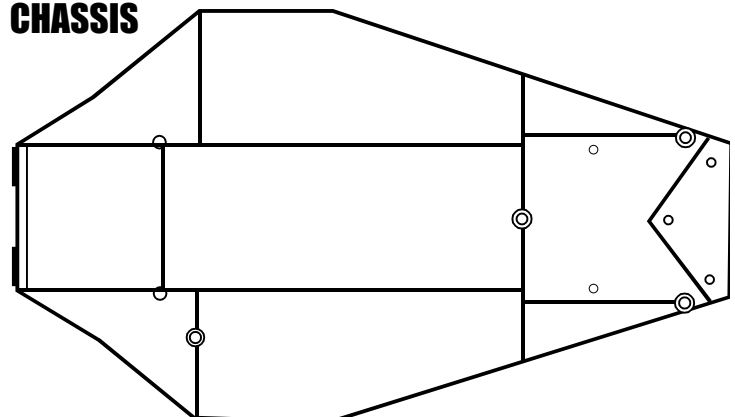

TRANSMISSION

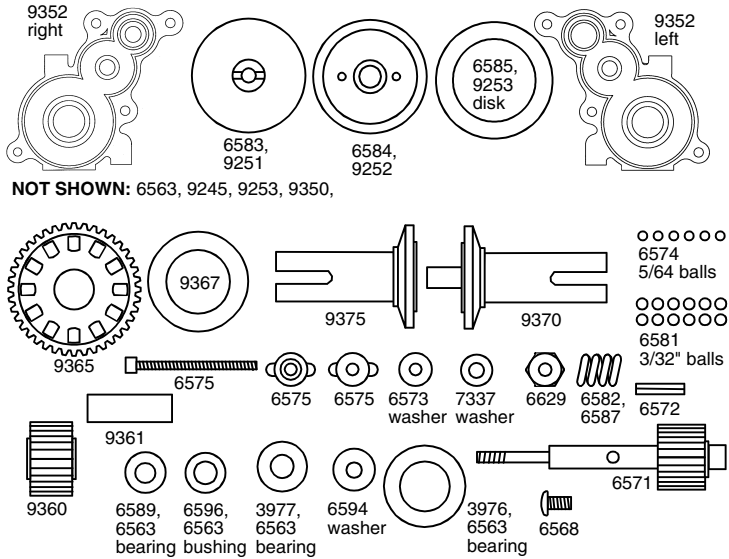

NOT SHOWN: 6563, 9245, 9253, 9350,

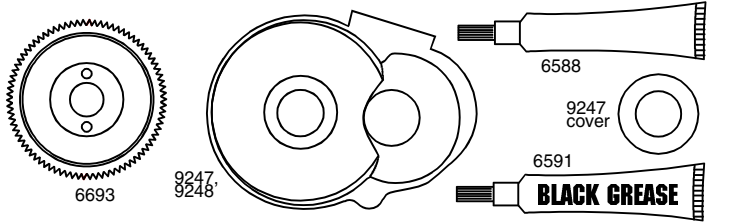

#6956 TOOLS

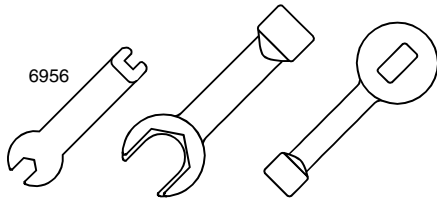

REEDY BRUSHES

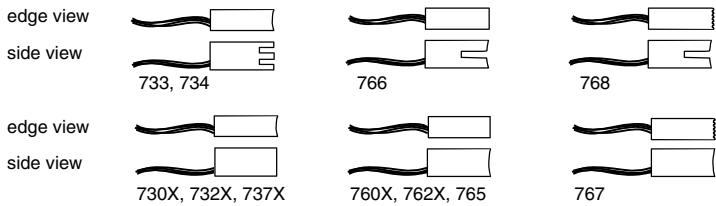

LINKAGE

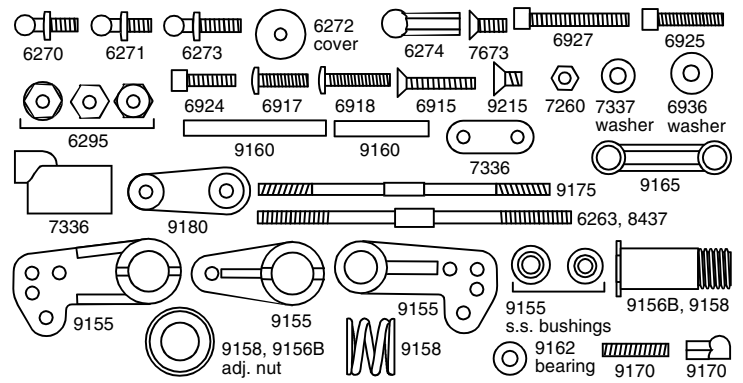

ALSO: 6295, 9150, 9162, 9215,

ELECTRICAL

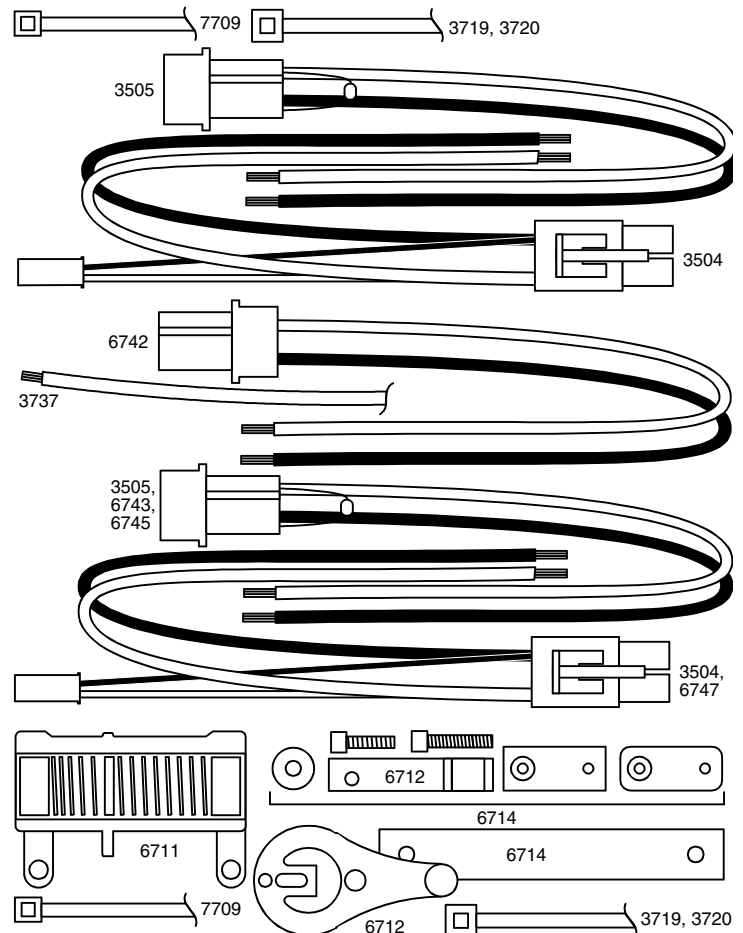

NOT SHOWN: 3736, 3740, 4436, 6714, 6725, 6744, 6746, 7527, 8850

RC10B3 2/2000			
SP-415	ASSOCIATED CAR CARRIER BAG, black nylon w/brass zipper. Fits #SP-100 car carrier box	1	39.95**
SP-410	TEAM ASSOCIATED JACKET, red,white & blue. Fully lined. Specify M,L,XL, XXL, XXXL	1	59.95**
SP-101	INNER BOXES 24" X 12" X 6." Replacement carboard inner boxes for #SP-100 car carrier box	3	5.25**
SP-100	ASSOCIATED CAR CARRIER BOX, cardboard outer box w/locking end flap (fits inside #SP-415 carrier bag), includes three 24" X 12" X 6" inner boxes. <i>Due to its large size, an additional \$15.00 must be added to UPS standard shipping charges</i>	1	15.00**
SP-41	B3 '97 WORLDS T-SHIRT. Printed front and back in full color on 100% cotton. Specify M, L, XL only.	1	13.00*
SP-41XXL	B3 '97 WORLDS T-SHIRT. Printed front and back in full color on 100% cotton. Size XXL.	1	15.00*
1207	FACTORY TEAM BLUE TITANIUM TURNBUCKLE KIT	set	27.00
3323	#8 ALUMINUM FLAT WASHER, thick	12	1.50
3325	8-32 X 1 1/4" ALUM. FLAT HEAD Machine Screw	6	1.50
3438	8-32 ALUMINUM LOCKNUT	3	1.50
3504	CONNECTOR, 2-pin JST mating pair, with pins	1	1.00
3505	CONNECTOR, 2-pin AMP, mating pair	1	2.00
3719	NYLON WIRE TIE, 6" heavy duty	12	2.00
3720	NYLON WIRE TIE, 8" heavy duty	12	2.00
3736	FAST CHARGE CORD, for 6 cell packs	1	5.50
3737	SILICONE WIRE, 16 gauge, 2 ft orange, 2 ft black	1	5.00
3740	CONNECTOR, 3-pin AMP, mating pair	1	2.50
3976	3/8 X 5/8" RUBBER SEALED BALL BEARING	PR	7.00
3977	3/16 x 3/8 BALL BEARING	pr	6.00
3977	3/16 X 3/8" RUBBER SEALED BALL BEARING	PR	6.00
3977	3/16 X 3/8" RUBBER SEALED BALL BEARING	pr	6.00
4145	4-40 X 5/16" ALUM. SOCKET HEAD Cap Screw	4	1.50
4187	PLASTIC WASHER/SHIM, 1/32" thick spacer for 1/8" shafts	12	1.00
4334	2-56 X 5/16" BUTTON HEAD socket screw	8	1.50
4404	TURNBUCKLE, for rear camber link	2	3.00
4436	SOCKET SET SCREW, 4-40 x 5/16"	4	1.50
4449	4-40 ALUM. LOCKNUT, small pattern (gold anodized)	5	2.50
4449	4-40 ALUM. LOCKNUT, small pattern (gold anodized)	5	2.50
5407	RED O-RING, replacements for shock rebuild kits #6440 and #6467	8	2.00
5420	SILICONE SHOCK OIL, 10 wt, 2 oz bottle	1	3.50
5421	SILICONE SHOCK OIL, 20 wt, 2 oz bottle	1	3.50
5422	SILICONE SHOCK OIL, 30 wt, 2 oz bottle	1	3.50
5423	SILICONE SHOCK OIL, 40 wt, 2 oz bottle	1	3.50
5425	SILICONE SHOCK OIL, 80 wt, 2 oz bottle	1	3.50
5427	SILICONE SHOCK OIL, 15 wt, 2 oz bottle	1	3.50
5428	SILICONE SHOCK OIL, 25 wt, 2 oz bottle	1	3.50
5429	SILICONE SHOCK OIL, 35 wt, 2 oz bottle	1	3.50
5435	SILICONE SHOCK OIL, 50 wt, 2 oz bottle	1	3.50
5436	SILICONE SHOCK OIL, 60 wt, 2 oz bottle	1	3.50
5437	SILICONE SHOCK OIL, 70 wt, 2 oz bottle	1	3.50
6133	B2 BUGGY BODY, clear Lexan	1	14.00
6142	B3 BUGGY BODY, clear Lexan	1	14.00
6154	PRO-LINE DEJA-VU TU body & wing, clear Lexan	1	16.95
6180	DRIVER, clear	1	2.00
6181	HIGH DOWN FORCE WING KIT, includes #6182 wing, #6190 wing mounts and wire (used in current RC10 car kits)	1	3.50
6182	HIGH DOWN FORCE WING, 5 1/2"	1	2.00
6183	HIGH DOWN FORCE WING, 7"	1	2.00
6190	WING MOUNTS, adjustable (Wing-Things)	pr	1.75

6193	WING MOUNTS, ALUMINUM, fits .065" and .078" wire (#9454 & #9455 pre-bent wire)	pr	3.50
6193B	FACTORY TEAM BLUE WING MOUNTS, ALUMINUM, fits .065" and .078" wire (#9454 & #9455 pre-bent wire)	pr	4.50
6194	COMPLETE TUNING GUIDE: B3. More than 70 illustrations detailing over 40 tuning options to set up your buggy to WIN!	1	3.95
6210	B2 FRONT BLOCK CARRIER, 30° caster (Kit standard)	pr	3.00
6215	B2 FRONT BLOCK CARRIER, 25° caster	pr	4.50
6220	ALUMINUM FRONT INLINE AXLES. (Axle thread is 5-40.) Uses #6222 black nylon locknut	pr	6.00
6220B	FACTORY BLUE ALUMINUM FRONT INLINE AXLES. (Axle thread is 5-40.) Uses #6222 black nylon locknut	pr	7.50
6221	B2 INLINE STEERING BLOCK, for alum. axles	pr	2.00
6222	SELF-THREADING NYLON LOCKNUT, for #6220 axles	8	2.00
6222	4-40/5-40 NYLON SELF THREADING LOCKNUTS, black	8	2.00
6223	KINGPIN, w/E-clips	2	2.50
6258	THREADED RODpr	2.00	
6262	B3 TURNBUCKLE, 1.65"	2	3.00
6263	B3 TURNBUCKLE, 2.06"	2	3.00
6270	SHORT BALL END, stainless steel, short thread, w/nuts & plastic ball cups	2	2.50
6271	SHORT BALL END, stainless steel, short thread, w/nuts & plastic ball cups	12	10.00
6271	SHORT BALL END, with nuts and plastic ball cups	12	10.00
6272	BALL END DUST COVER, foam	28	2.00
6272	BALL END DUST COVER, foam	28	2.00
6273	LONG BALL END, stainless steel, long thread (1/10" longer thread than #6270) w/nuts & plastic ball cups	2	2.50
6274	PLASTIC BALL CUPS, molded nylon (spares for #6270, #6271 or #6273)	14	5.00
6280	8-32 X 1/2" ALUM. FLAT HEAD Machine Screw	16	2.00
6281	8-32 X 7/8" ALUM. FLAT HEAD Machine Screw	6	2.00
6284	4-40 X 1/4" ALUM. SOCKET HEAD Cap Screw	12	4.00
6288	4-40 X 1/4" BUTTON HEAD Socket Screw	6	2.00
6292	4-40 X 3/8" FLAT HEAD Socket Screw	6	2.00
6292	4-40 X 3/8" FLAT HEAD Socket Screw	6	2.00
6295	NUT, 4-40, 6 each plain, lock, and nylon	18	2.00
6295	NUT, 4-40, 6 each plain, lock, and nylon	18	2.00
6295	NUT, 4-40, 6 each plain, lock, and nylon	18	2.00
6296	8-32 LOCKNUTS, 6 each alum. and nylon	12	3.00
6299	1/8" E-CLIPS	12	1.00
6299	1/8" E-CLIPS	12	1.00
6312	CLEAR CHASSIS PROTECTIVE SHEET to protect the chassis finish, 6 1/2" X 18"	1	6.50
6332	HOOD PIN	6	.75
6338	ANTENNA KIT, with hardware	1	2.00
6366	REAR HUB CARRIER, 1.5° toe-in (per side). Requires special 3/16" X 3/8" flanged bearing #9277 (only fits #9275 or #7367 rear axles)	pr	4.50
6370	DOG BONE (rear half shaft) for all basic and sport buggies	1	6.00
6372	DOG BONE SPRING and spacers	4	.75
6373	1/4" REAR AXLE SHIMS/SPACERS .010" thick for all 1/4" axles	14	1.50
6374	REAR STUB AXLE 1/4" dia., with roll pin (fits only #7359 bearing aor #7360 bushing)	1	5.00
6375	ROLL PIN for stub axle)only fits #6374 axle)	6	.75
6388	CONE WASHER, 1/4" x .400" .006"	4	1.00
6416	UNOBTAINIUM SHOCK SHAFT, 1.32 stroke. Titanium carbonitrade coated for smoother action	1	6.00
6417	UNOBTAINIUM SHOCK SHAFT, 1.02 stroke. Titanium carbonitrade coated for smoother action	1	6.00
6418	UNOBTAINIUM SHOCK SHAFT, 0.71 stroke. Titanium carbonitrade coated for smoother action	1	6.00
6424	REAR SHOCK BODY, 1.32 stroke (standard)	1	6.75

6428	END CAP, molded composite	1	2.25
6429	SHOCK ASSEMBLY TOOL	1	1.00
6435	REAR SHOCK BODY, 1.32 stroke (hard anodized, PTFE sealed)	1	8.50
6439	END CAP, black anodized aluminum	1	3.00
6440	REBUILD KIT for Standard and Racing (PTFE-coated) shocks, for 4 shocks,	set	4.00
6459	SHOCK SHAFT, 1.02 stroke	1	3.00
6460	SHOCK SHAFT, 0.71 stroke	1	3.00
6464	PISTON, #1 fits all 0.4" bore shocks	4	3.00
6465	PTFE SHOCK PISTON, 4 each of #1, #2 & #3. To adjust dampening. Fits all 0.4" bore shocks	12	3.00
6466	SHOCK DOWNSTOPS, (travel limiters), 4 ea. of 3 sizes 1/8" (.125"), 1/16" (.062") and 1/32" (.031")	set	1.50
6466	SHOCK DOWNSTOPS, (travel limiters), 4 ea. of 3 sizes 1/8" (.125"), 1/16" (.062") and 1/32" (.031")	set	1.50
6469	O-RING, shock end-cap to body seals	4	1.50
6473	SHOCK BUSHING	4	1.00
6475	PRELOAD SPACERS, collars & cups. 4 thicknesses, 4 sets each	4	3.00
6478	REAR SHOCK SPRING, Silver, 2.10 lb.	2	1.50
6480	REAR SHOCK SPRING, Green, 1.90 lb.	2	1.50
6481	REAR SHOCK SPRING, Black, 1.74 lb.	2	1.50
6494	FRONT SHOCK SPRING, Green, 3.50 lb.	2	1.50
6496	FRONT SHOCK SPRING, Silver, 3.85 lb.	2	1.50
6568	ASSOC. SPUR GEAR SCREWS, 4-40 X 3/16" Button Head Socket screw	4	1.50
6569	MOTOR PLATE SPACERS & END CAP	Set	1.50
6571	DRIVE GEAR/SHAFT assembly, w roll pin	1	9.00
6572	DRIVE SHAFT ROLL PIN	6	1.00
6573	DIFF THRUST WASHER	2	3.00
6574	PRECISION DIFF THRUST BALL, 5/64" (replaces #6576)	6	2.00
6575	LOCKING T-NUT, DIFF THRUST BOLT, DIFF THRUST BOLT COVER, and dogbone spacers	set	2.00
6581	CARBIDE DIF BALL, large 3/32"	12	12.00
6582	DIF THRUST SPRING	1	1.50
6583	TORQUE CONTROL HUB, inner NOT FOR B3 OR T3	1	7.50
6584	TORQUE CONTROL HUB, outer NOT FOR B3 OR T3	1	7.50
6585	RULON CLUTCH DISK NOT FOR B3 OR T3	1	3.00
6587	TORQUE CONTROL SPRING & LOCKNUT	set	1.50
6588	BLACK GREASE	1	2.50
6589	DIF BEARING, 5/32 X 5/16 unflanged	pr	13.00
6591	TRANNY DIF LUBE	1	2.50
6594	THRUST BEARING WASHER, replaces #6586 thrust bearing	set	2.00
6596	BUSHING, 3/16" X 5/16", unflanged	2	1.00
6629	DIF LOCKNUT, 5-40	6	1.00
6693	81 TOOTH, 48 PITCH	1	4.00
6694	85 TOOTH, 48 PITCH	1	4.00
6695	87 TOOTH, 48 PITCH	1	4.00
6697	83 TOOTH, 48 PITCH	1	4.00
6711	RESISTOR, throttle control (forward and brake only)	1	15.00
6712	WIPER ARM, throttle control1	1	2.50
6714	BYPASS KIT, for throttle control	1	3.50
6725	SERVO TAPE STRIP	2	2.50
6742	CONNECTOR, 2 mail pin AMP connector with 7" silicone wire leads	1	2.50
6743	CONNECTOR, 2 female pin AMP connector with 7" silicone wire leads	1	2.50
6744	WIRE HARNESS, input, 3 male pin AMP connector with radio diodes for non-BEC receiver	1	4.50
6745	WIRE HARNESS, motor output, with one .1ufd. capacitor installed	1	3.00
6746	ADAPTER, Tamiya 2 pin JST battery connector with old RC10 3 pin AMP connector	1	4.00
6747	WIRE HARNES, input, 2 pin JST Tamiya plug with JST BEC connector	1	3.00
6825	REAR TIRE, "Holeshot," 2.2", Proline M2 compound with foam inserts	pr	12.50

6860	4-40 X 3/8" ALUM. SOCKET HEAD Cap Screw	6	2.50
6878	FRONT TIRE, "Four Rib", 2.2", Proline M2 compound with foam inserts	pr	10.50
6880	FOAM TIRE INSERT, soft, supports sidewall of soft compound front & rear tires.	pr	2.00
6903	3/8" X 5/8" BALL BEARING, unflanged, PTFE sealed	pr	20.00
6906	3/16" X 3/8" BALL BEARING, unflanged	pr	13.00
6915	4-40 X 5/8" FLAT HEAD Socket Screw	6	2.00
6915	4-40 X 5/8" FLAT HEAD Socket Screw	6	2.00
6915	4-40 X 5/8" FLAT HEAD Socket Screw	6	2.00
6917	4-40 X 3/8" BUTTON HEAD Socket Screw	6	2.00
6918	4-40 X 1/2" BUTTON HEAD Socket Screw	6	2.00
6922	4-40 X 1/2" FLAT HEAD Socket Screw	6	2.00
6924	4-40 X 3/8" SOCKET HEAD Cap Screw	6	2.00
6924	4-40 X 3/8" SOCKET HEAD Cap Screw	6	2.00
6924	4-40 X 3/8" SOCKET HEAD Cap Screw	6	2.00
6925	4-40 X 1/2" SOCKET HEAD Cap Screw	6	2.00
6925	4-40 X 1/2" SOCKET HEAD Cap Screw	6	2.00
6927	4-40 X 3/4" SOCKET HEAD Cap Screw	6	2.00
6927	4-40 X 3/4" SOCKET HEAD Cap Screw	6	2.00
6927	4-40 X 3/4" SOCKET HEAD Cap Screw	6	2.00
6929	SOCKET HEAD Cap Screw, 4-40 X 3/8" with hole	4	2.00
6933	4-40 X 5/16" ALUM. FLAT HEAD Socket Screw	6	2.00
6934	4-40 X 3/8" ALUM. FLAT HEAD Socket Screw	6	2.00
6935	4-40 X 1" ALUM. SOCKET HEAD Cap Screw	4	3.00
6936	#4 ALUMINUM WASHER	10	1.00
6936	#4 ALUMINUM WASHER	10	1.00
6936	#4 ALUMINUM WASHER	10	1.00
6936	#4 ALUMINUM FLAT WASHER	10	1.00
6937	4-40 ALUMINUM LOCKNUTS (blue anodized)	6	3.00
6938	4-40 X 1/2" ALUM. FLAT HEAD Socket Screw	6	2.00
6939	4-40 X 1/4" ALUM. FLAT HEAD Socket Screw	6	2.00
6950	ALLEN WRENCH SET, .050", 1/16", 5/64", 3/32"	set	2.50
6951	4-40 X 1/8" SOCKET SET SCREW, with Allen wrench	6	2.50
6951	4-40 X 1/8" SOCKET SET SCREW with Allen Wrench	6	2.50
6956	ASSOCIATED MOLDED TOOL SET	set	4.50
7210	B3/T3 FRONT BLOCK CARRIER, 30 deg. caster	Pr	3.00
7211	B3/T3 KINGPIN BALL END	2	4.00
7212	B3/T3 FRONT BLOCK CARRIERS, 25 deg. caster	Pr	4.50
7217	B2/T2 SHOCK ROD END, nylon w/plastic pivot ball	2	3.00
7217	SHOCK ROD END, nylon w/plastic pivot ball	2	3.00
7217	B3/B2/T2 SHOCK ROD END, nylon w/plastic pivot ball	2	3.00
7220	B3/T3 FRONT STEERING BLOCK	Pr	2.00
7221	B3/T3 FRONT AXLE, aluminum with #6222 nuts	2	6.00
7221B	FACTORY BLUE INLINE FRONT AXLE	pr	7.50
7230	B3/T3 PLASTIC BALL END CUPS, molded	12	5.00
7260	4-40 SMALL PATTERN PLAIN NUT	12	2.00
7260	4-40 SMALL PATTERN PLAIN NUT	12	2.00
7302	B3/B2/T3 CHASSIS, LONG, molded Carbon Fiber composite (standard chassis length for T3)	1	25.00
7304	B3/B2/T3 CHASSIS, LONG, molded Carbon Fiber composite (standard chassis length for T3)	1	45.00
7330	BATTERY HOLD DOWN STRAP, LONG, molded composite	1	3.00
7331	BATTERY HOLD DOWN STRAP, LONG, molded Carbon Fiber composite	1	5.00
7336	STEERING SERVO MOUNT KIT, molded mounts, spacer, screws & washers	set	2.50
7337	SERVO MOUNT WASHERS, steel (gold colored)	4	1.00
7365	REAR HUB CARRIER, 0° toe-in per side (uses unflanged bearings) NOT FOR B3 OR T3.	pr	3.50
7366	B3/T3 REAR HUB CARRIER, 3° toe-in, molded composite	pr	3.50
7368	UNIVERSAL SHIMS, fits #9275 or #7367 rear axles	14	1.50

7369	B2/T2 AXLE SPRING PINS, fits #9275 or #7367 axles	4	1.00
7373	MOTOR PLATE GASKET	1	1.50
7377	REAR AXLE BEARING SPACER, aluminum (fits 3/16" rear axle)	2	1.50
7380	CVD 3/16" AXLE	1	8.00
7381	CVD REBUILD KIT for two axles	Set	8.50
7434	REAR SHOCK SPRING, Blue, 2.55 lb.	2	1.50
7435	REAR SHOCK SPRING, Gold, 2.75 lb.	2	1.50
7436	REAR SHOCK SPRING, Red, 3.03 lb.	2	1.50
7527	SERVO MOUNTS for throttle servo & steering servo	1	2.50
7658	8-32 X 3/8" ALUM. FLAT HEAD Machine Screw	6	2.00
7673	4-40 X 5/16" FLAT HEAD Socket Screw	6	2.00
7673	4-40 X 5/16" FLAT HEAD Socket Screw	6	2.00
7673	4-40 X 5/16" FLAT HEAD Socket Screw	6	2.00
7709	NYLON WIRE TIE, 4" light duty	12	1.25
7801	4-40 X 5/8" ALUM. SOCKET HEAD Cap Screw	8	2.50
7873	4-40 X 7/16" ALUM. FLAT HEAD Socket Screw	8	2.50
8232	FRONT SHOCK SPRING, Black, 3.20 lb.	2	1.50
8437	B2 TURNBUCKLE, for steering tie-rod	2	3.00
8828	ROLL BAR CUP SET. Closed and open cup with 5/16" set screw	2pr	2.00
8828	ROLL BAR CUP SET. Closed and open cup with 5/16" set screw	2pr	2.00
8830	ROLL BAR PIVOT, aluminum, with #6951 set screw	2	4.00
8830	ROLL BAR PIVOT, aluminum, with #6951 set screw	2	4.00
8850	RESISTON BRACKET, aluminum, black anodized	Set	7.00
9003	RC10B3 BASIC PLUS BUGGY KIT, Basic sport bushing kit with motor, but without the mechanical speed control. Less radio and batteries	1	215.00
9013	RC10B3 SPORT BUGGY KIT, with mechanical speed control, kit motor, bronze bushings, 2.40:1 Assoc. transmission, less radio and batteries	1	255.00
9021	RC10B3 WORLDS UPGRADE KIT. Upgrades your B3 to Worlds specs. Includes Pro-Line's Deja-Vu Tu body, low-profile rear shock tower, wide-body Pro-Line front and rear wheels.	1	29.95
9032	RC10B3 TEAM BUGGY KIT. Includes ball bearing Assoc. transmission, PTFE-coated shocks, Pro-Line tires, MIP CVD's, less radio and batteries.	1	299.95
9043	FACTORY TEAM B3. Includes Factory Team Blue and titanium parts, PTFE-coated shocks, ball bearing Assoc. transmission, Pro-Line tires, MIP CVD's, less radio and batteries.	1	369.95
9103	B3/T3 FRONT ANTI-ROLL BAR WIRE, 2 sizes.	2	2.50
9104	B3/B2 FRONT ANTI-ROLL BAR KIT, light & heavy bars included in kit	pr	8.00
9105	B2 FRONT A-ARM, molded composite	pr	6.00
9106	B2 FRONT A-ARM, molded Carbon Fiber composite	pr	9.00
9107	B3 FRONT SUSPENSION ARMS, composite	Pr	6.00
9108	B3 FRONT SUSPENSION ARMS, molded Carbon Fiber composite	Pr	9.00
9110	B2 FRONT INNER HINGE PIN, special hardened tool steel	2	5.00
9115	B2/B3 FRONT OUTER HINGE PIN,	2	3.00
9120	B2/B3 FRONT CROSS BRACE, aluminum	1	1.50
9125	B2/B3 FRONT BULKHEAD, nylon	1	4.00
9130	B2/B3 FRONT TOP PLATE, molded composite	1	5.00
9131	B2/B3 FRONT TOP PLATE, molded Carbon Fiber composite	1	8.00
9140	B2 FRONT SHOCK STRUT, fiberglass	1	7.00
9141	B2 FRONT SHOCK STRUT, graphite	1	13.00
9142	B3 FRONT SHOCK STRUT, fiberglass	1	7.00
9143	B3 FRONT SHOCK STRUT, graphite	1	13.00
9145	BALL END, long thread (low profile) black, w/nuts and plastic cups (for front shock strut)	pr	3.00
9150	B3/B2/T3 SERVO SAVER KIT, w/turnbuckles for steering tie-rods	1	11.00
9155	B3/B2/T3 SERVO SAVER, plastic parts only	1	3.50
9156B	B3/B2/T3 FACTORY BLUE SERVO SAVER HUB & COLLAR	1	6.50
9158	B3/B2/T3 NUT, TUBE & SERVO SAVER SPRING	1	4.50
9160	B3/B2/T3 SERVO SAVER & BELLCRANK PINS	2	3.00

9162	B3/B2/T3 OPTIONAL STEERING BELLCRANK BEARINGS, 1/8" X 1/4" flanged ball bearing, (replaces bushings in right side steering bellcrank)	2	15.00
9165	B3/B2/T3 STEERING DRAG LINK, molded nylon	1	2.00
9170	B3/B2/T3 ADJUSTABLE SERVO LINK, 4-40 X 1/2" set screw with special plastic ball cups	1	2.00
9175	B2 TURNBUCKLE, for front camber link	2	3.00
9180	SERVO HORNS, molded (1 ea. fits Airtronics, Futaba, Hitec, or JRpropo)	1	2.50
9199	B3/B2 CHASSIS, STANDARD, molded Carbon Fiber composite	1	45.00
9200	B3/B2 CHASSIS, STANDARD, molded composite	1	25.00
9201	B3/B2 CHASSIS, SHORT, molded composite	1	25.00
9202	B3/B2 CHASSIS, SHORT, molded Carbon Fiber composite	1	45.00
9210	B3/B2/T2 FRONT KICKUP (nose plate), aluminum, black hard anodized	1	7.50
9210B	B3/B2/T2 FACTORY BLUE FRONT KICKUP (nose plate), aluminum, blue anodized	1	10.00
9215	6-32 X 3/16" FLAT HEAD Machine Screw, phillips	6	1.50
9215	6-32 X 3/16" FLAT HEAD MACHINE SCREWS, Phillips (for mounting front kickup to chassis)	6	1.50
9220	FRONT BUMPER, molded nylon	1	2.50
9229	BATTERY HOLD DOWN STRAP, STANDARD, molded Carbon Fiber Composite	1	5.00
9230	BATTERY HOLD DOWN STRAP, STANDARD, molded composite	1	3.00
9231	BATTERY HOLD DOWN STRAP, SHORT, molded composite	1	3.00
9232	BATTERY HOLD DOWN STRAP, SHORT, molded Carbon Fiber composite	1	5.00
9235	BATTERY PADS, 3 adhesive foam pads for sides and bottom rear of battery slot	1	3.00
9238	BATTERY SPACERS, foam pads for spacing battery weight	2	2.00
9241	B3/B2/T3 REAR CHASSIS PLATE, aluminum, black hard anodized	1	9.00
9241B	FACTORY BLUE REAR CHASSIS PLATE	1	12.00
9245	B3/B2/T3 MOTOR MOUNT, aluminum, black anodized	1	6.00
9245B	B3/B2/T3 FACTORY BLUE MOTOR MOUNT, aluminum, blue anodized	1	8.00
9245	B3/B2/T3 MOTOR MOUNT, aluminum, black anodized	1	6.00
9247	B3/B2/T3 GEAR DUST COVER, w/black insert button	1	1.50
9248	GEAR DUST COVER, fits Losi Hydra Drive or Schumacher Viscous Drive, w/black insert button	1	1.50
9251	B3/T3 TORQUE CONTROL HUB, inner	1	7.50
9252	B3/T3 TORQUE CONTROL HUB, outer	1	7.50
9253	B3/T3 CLUTCH DISC	1	3.00
9254	B3/T3 REAR ANTI-ROLL BAR KIT, light & heavy bars included in kit	1	8.00
9255	B2 REAR A-ARMS, molded composite	pr	7.00
9256	B2 REAR A-ARMS, molded Carbon Fiber composite	pr	10.00
9257	B3 REAR A-ARMS, composite	pr	7.00
9258	B3 REAR A-ARMS, Carbon Fiber composite	pr	10.00
9259	REAR ANTI-ROLL BAR KIT, with light & heavy bars	2	2.50
9260	B3/B2/T3 REAR INNER HINGE PIN, with E-clips	pr	3.00
9263	B3/B2/T3 REAR OUTER HINGE PIN, with E-clips	pr	2.50
9266	B3/B2/T3 REAR SUSPENSION MOUNTS, 2° toe-in (per side)	pr	2.00
9267	B3/B2/T3 REAR SUSPENSION MOUNTS, 3° toe-in (per side) and 3° anti-squat	pr	2.00
9268	B3/B2/T3 REAR SUSPENSION MOUNTS, 3° toe-in (per side) and 0° anti-squat	pr	2.00
9269	5-40 X 1/2" FHSScrew	6	2.00
9270	B2 REAR SHOCK STRUT, molded composite	1	5.00
9271	B2 REAR SHOCK STRUT, molded Carbon Fiber composite	1	7.50
9272	REAR ANTI-ROLL BAR MOUNTS AND SCREWS, 2-56 x 5/16" button head socket screw	Set	2.00
9273	DOG BONE SPACER, ith spring. Replacement spacers & springs for all Sport and Basic kits.	2	1.00
9276	B3/B2 MIP CVD's, rebuildable universal axles. Will also fit RC10 series with #9277 bearings.	Pr	35.50
9277	3/16" X 3/8" BALL BEARING, flanged (for use with #6366 rear hub carrier and #9275 rear axle) NOT FOR B3 OR T3.	pr.	15.00

9278	B3/B2 CVD DOG BONE	1	11.50
9279	B3 LOW PROFILE REAR SHOCK STRUT, molded composite	1	5.00
9280	B3 FACTORY TEAM LOW PROFILE REAR SHOCK STRUT, molded Carbon Fiber composite	1	7.50
9300	B3/B2 FRONT SHOCK KIT, .89" shock body & .71" shock shaft (hard anodized, PTFE sealed bodies)	2	30.00
9310	B3/B2 FRONT SHOCK BODY, .89" stroke (hard anodized, PTFE sealed)	1	7.75
9311	B3/B2 FRONT SHOCK BODY, .89" stroke (gold anodized)	1	6.75
9315	B3/B2 REAR SHOCK KIT, 1.32" shock body & 1.02" shock shaft (hard anodized, PTFE sealed bodies)	2	30.00
9350	B3/B2/T3 2.40:1 ASSOC. TRANSMISSION KIT, with ball bearings and Associated Torque Control	1	120.00
9352	B3/B2/T3 TRANSMISSION CASE, right and left sides (w/motor plate spacers), for 2.40:1 transmission	set	9.00
9360	B3/B2/T3 IDLER GEAR, molded	1	2.00
9361	B3/B2/T3 IDLER GEAR SHAFT	1	2.00
9365	B3/B2/T3 DIFF GEAR, for 2.40:1 transmission only	1	2.50
9367	B3/B2/T3 DIFF DRIVE RINGS, for 2.40:1 transmission only	2	1.50
9370	B3/B2/T3 LEFT DIFF OUTDRIVE HUB	1	7.50
9375	B3/B2/T3 RIGHT DIFF OUTDRIVE HUB	1	7.50
9380	B2 TRANSMISSION BRACE, molded composite	1	4.00
9381	B2 TRANSMISSION BRACE, molded Carbon Fiber composite	1	6.00
9390	B3/T3 BALL BEARING SET	Set	45.00
9453	B2/B3 WING KIT, 6182 wing, mounts, and #9454 prebent wing wire (.065")	1	5.00
9454	WING WIRE, .065" prebent	1	2.50
9455	WING WIRE, .078":prebent	1	2.50
9480	ONE PIECE FRONT WHEEL, 2.125" (2 1/8"), white, uses #3977 ball bearing	pr	4.00
9480B	ONE PIECE FRONT WHEEL, 2.125" (2 1/8"), black, uses #3977 ball bearing	pr	4.00
9480Y	ONE PIECE FRONT WHEEL, 2.125" (2 1/8"), florescent yellow, uses #3977 ball bearing	pr	4.00
9481	ONE PIECE FRONT WHEEL, 2.2", white, uses #3977 ball bearing	pr	4.00
9481B	ONE PIECE FRONT WHEEL, 2.2", black, uses #3977 ball bearing	pr	4.00
9481Y	ONE PIECE FRONT WHEEL, 2.2", fluorescent yellow, uses #3977 ball bearing	pr	4.00
9482	ONE PIECE FRONT WHEEL, WIDE-BODY, 2.2", white	pr	5.50
9490	B3/B2 ONE PIECE REAR WHEEL, 2.2", white, fits 2.15" or 2.2" rear tires	pr	6.00
9490B	B3/B2 ONE PIECE REAR WHEEL, 2.2", black, fits 2.15" or 2.2" rear tires	pr	6.00
9490Y	B3/B2 ONE PIECE REAR WHEEL, 2.2", fluorescent yellow, fits 2.15" or 2.2" rear tires	pr	6.00
9491	ONE PIECE REAR WHEEL, WIDE-BODY, 2.2", white	pr	5.50