

1:10 RC10GT GAS TRUCK CATALOG

NORRCA TRUCK WORLD CUP CHAMPION, 1994, 1996, 1998!

CATALOG #10GT Dec. 1998

This free catalog is updated yearly; is yours current?
Prices subject to change without notice.

If you cannot obtain parts from your distributor or dealer, you may order them directly from us.

(We're sorry, you cannot order truck kits from us.)

For the latest in new products and online help, visit our web site:

<http://www.rc10.com>

Includes photos of bodies, decals, tires, wheels, apparel

ORDERING INSTRUCTIONS

1. Write out order on separate sheet of paper if order form is missing. Include part no., quantity, and price of each item. Include your phone no., full name and return address. DO NOT SEND CASH.

2. California residents only add sales tax: 7.75% in Orange County, 6.25% elsewhere.

3. Add shipping fee of \$4.25 to all orders, except for faster Red, Orange & Blue Label services and international orders, which require extra charges.

4. C.O.D. fee is \$4.75 (C.O.D. = "Collect On Delivery")

5. All international orders must be prepaid by International Money Order in US funds.

6. Mail order to:

Associated Electrics, Inc.
3585 Cadillac Ave.
Costa Mesa, CA 92626 USA

7. Or call (714) 850-9342. Please have your order ready before calling. Or FAX: 714-850-1744. Include your phone no., full name and return address.

8. Credit Card orders welcome. Use phone or fax numbers above. Include your credit card type (AmEx, MC, VISA, Discover), card number, expiration date, and name as it appears on card.

RC10GT BUSHING KIT

Will accept most side exhaust .12 through .17 engines that use a standard .12 crankshaft design. Check with your dealer for correct engine fit.

FOR PULL START ENGINES

7055	COMPLETE SPORT TRUCK (less engine). Complete bushing kit with gold shocks. Requires the addition of .12ci/.15ci pull start gas engine and radio system to complete. (Associated's Engine Installation Pack included in kit.)	1	320.00
------	--	---	--------

RC10GT BEARING KITS

Will accept most side exhaust .12 through .17 engines that use a standard .12 crankshaft design. Check with your dealer for correct engine fit.

FOR PULL START ENGINES

7065	COMPLETE TEAM TRUCK (less engine). Complete ball bearing kit with hard anodized shocks and now with MIP CVD rear axles. Requires	1	445.00
------	--	---	--------

the addition of .12ci/.15ci pull start gas engine and radio system to complete. (Associated Engine Installation Pack included in kit.)

FOR NON PULL START ENGINES

7066	COMPLETE TEAM TRUCK (less engine). Complete ball bearing kit with hard anodized shocks and now with MIP CVD rear axles. Requires the addition of .12ci/.15ci non pull start gas engine and radio system to complete. (Associated's Engine Installation Pack included in kit.)	1	445.00
------	---	---	--------

CLEAR TRUCK BODIES & ACCESSORIES

6131	RC10GT GAS TRUCK BODY. Body style shown on page 2, unpainted clear Lexan (will not fit electric RC10T's)	1	18.00
6134	NARROW GAS TRUCK BODY II '96. (Requires #7654 or 7656 shock strut.) Now kit std.	1	18.00
6180	DRIVER, clear	1	2.00

PRODUCT SPOTLIGHT

REEDY CAR WASH FOR REMOVING, POLISHING, CLEANING

Reedy's Car Wash removes fuel residue, tire scuff marks, and decal adhesives safely, quickly and easily from your Lexan body—without damaging the Lexan plastic. Biodegradable, it cleans and polishes both chassis and plastic components. Not for motors or electrical equipment. Simply spray on from this handy, 4 oz. size bottle, let sit for two to three minutes, then wipe off. #711

711	REEDY CAR WASH. Great for cleaning gas and electric cars and bodies. Lexan safe and biodegradable. Not for electrical components. 4 oz. bottles sold in cases of 12 only. Price reflects \$6.00 per bottle. (Purchase individual bottles at your hobby shop or race track.)	1 case	72.00
6190	WING MOUNT, adjustable	pr	1.75
6193	SUPER WING THINGS, aluminum. Fits .065" and .078" wire	pr	3.50
6193B	NEW! FACTORY TEAM BLUE WING MOUNT	pr	4.50
7185	TRUCK REAR SPOILER	1	2.00

DECALS & STICKERS

3811	RC10GT DECALS, 2 sizes of "RC10GT", fluorescent red & yellow with "GT" in white smoke	1	2.00
3824	NEW! FACTORY TEAM "DRIVER" DECAL, 10" x 4.25"	1	2.00
3825	NEW! FACTORY TEAM LOGO DECAL SHEET	1	2.00
7195	TRUCK DECAL SHEET, for the #6122 body	1	4.00
7197	RC10GT GAS TRUCK DECAL SHEET, for the #6131 Gas Truck body, 4 color Mylar	1	4.00
6196	DECAL SHEET, Associated logos, 4 colors	1	2.00
3817	ASSOCIATED BUMPER STICKERS, 1 large, 1 small. Red, white & blue.	1	4.00
3818	TEAM ASSOCIATED logo decal sheet, black	1	1.00
3819	TEAM ASSOCIATED logo decal sheet, white	1	1.00

Reusable, colored, Mylar Wheel Dots are adhesive-backed to cover the outside of buggy & truck wheels. Includes Associated and Reedy logos on each. 4 dots per package

6855	WHEEL DOTS, fluorescent pink	4	2.00
6856	WHEEL DOTS, fluorescent red	4	2.00
6857	WHEEL DOTS, fluorescent green	4	2.00

non-standard discount item. **net or short discount item.

ASSOCIATED ELECTRICS RC10GT CATALOG

RICHARD SAXTON WINS THE 1998 NORRCA TRUCK WORLD CUP WITH HIS RC10GT!!

Part #	Description	Qty	Price
6858	WHEEL DOTS, fluorescent yellow	4	2.00
FRONT SUSPENSION			
7200	TRUCK FRONT SUSPENSION KIT, no shocks (Bag 7-1)	1	30.00
7206	TRUCK FRONT A-ARM, (new design) black composite material	pr	7.00
7207	FRONT BULKHEAD, nylon	1	5.00
7208	FRONT BULKHEAD ALUMINUM SUPPORT	1	1.50
6210	FRONT BLOCK CARRIER, 30 deg. caster (kit standard)	pr	3.00
6211	FRONT BLOCK CARRIER, 5 deg. caster	pr	4.50
6212	FRONT BLOCK CARRIER, 10 deg. caster	pr	4.50
6213	FRONT BLOCK CARRIER, 15 deg. caster	pr	3.00
6214	FRONT BLOCK CARRIER, 20 deg. caster	pr	4.50
6215	FRONT BLOCK CARRIER, 25 deg. caster	pr	4.50
6220	ALUMINUM FRONT INLINE AXLE. Axle thread is now 5-40, not 4-40. Uses #6222 black nylon locknut. Now standard on all off road cars & trucks.	pr	6.00
6220B	FACTORY TEAM ALUMINUM FRONT INLINE AXLE. Blue anodized. Uses #6222 black nylon locknut.	pr	7.50
6221	INLINE STEERING BLOCK, for alum. axles. Now standard on all off road cars & trucks.	pr	2.00
6222	SELF-THREADING NYLON LOCKNUT, for #6220 axles	8	2.00
6223	KINGPIN with clips, 1.00"	pr	2.50
6561	STEALTH DIFF LUBE	1	2.50
1520	NEW! FACTORY TEAM TITANIUM TURNBUCKLE/HINGE PIN COMBO	1	46.00
1620	NEW! FACTORY TEAM TITANIUM HINGE PIN SET	1	18.00
7209	HINGE PIN, inner, with clips, 1.675"	pr	2.50
6227	HINGE PIN, outer, with clips, 1.020"	pr	2.50
6274	BALL CUP, spares for #6270, #6271, #6273, nylon	14	5.00
7230	PLASTIC BALL END CUPS, molded	12	5.00
7215	T2/GT RACING FRONT SHOCK STRUT, composite, replaces #7214 (standard in kits from July '96)	1	7.00
7216	T2/GT RACING FRONT SHOCK STRUT, Carbon Fiber composite	1	12.00
7240	REBUILD KIT (screws, clips, pins etc.)	1	13.00
6295	4-40 NUTS, 6 each, plain nut, nylon & steel locknuts	18	2.00
7260	THIN PLAIN NUT, 4-40, for ball ends	12	2.00

Part #	Description	Qty	Price
7420	SOCKET HEAD Cap screw, 4-40 x 5/8", special (truck front lower shock screw). Only fits original style truck front A-arms	2	1.00
LINKAGE & HARDWARE			
1280	NEW! FACTORY TEAM TITANIUM TURNBUCKLE SET, blue anodized	1	30.00
1408	NEW! FACTORY TEAM TITANIUM TURNBUCKLE, 2.65" / 67mm, blue anodized	pr	10.00
7251	TURNBUCKLE, 1.0"	1	1.50
7253	TURNBUCKLE, Tie Rod, 2.620"	1	3.00
7531	SERVO SAVER, Gas truck, plastic only	pr	2.50
7532	SERVO SAVER KIT COMPLETE, gas truck	1	11.00
9156	SERVO SAVER THREADED TUBE. Also replaces #7258	1	2.50
9157	SERVO SAVER SPRING & NUT. Also replaces #7257	1	2.00
6271	SHORT BALL ENDS, steel, (4-40 threaded ball studs) w/plastic end caps	12	10.00
6265	STEERING DRAG LINK, molded	1	2.00
6272	BALL END DUST COVER	28	2.00
6274	BALL CUP, spares for #6270, #6271, #6273, nylon	14	5.00
7230	PLASTIC BALL END CUPS, molded	12	5.00
6280	ALUM. FLAT HEAD Machine screw, 8-32 X 1/2	16	2.00
6285	SOCKET HEAD Cap screw, 4-40 X 1/4" steel	12	2.00
6295	4-40 NUTS, 6 each, plain nut, nylon & steel locknuts	18	2.00
6291	FLAT HEAD Socket screw, 4-40 X 1/4"	6	2.00
6925	SOCKET HEAD Cap screw, 4-40 X 1/2"	6	2.00
6927	SOCKET HEAD Cap screw, 4-40 X 3/4"	6	2.00
6936	ALUMINUM WASHER, #4	10	1.00
6951	SET SCREWS, 4-40 x 1/8", with wrench	6	2.50
7260	THIN 4-40 NUT, for ball ends	12	2.00
7633	BUTTON HEAD Socket screw, 4-40 X 5/8"	6	2.00
7658	FLAT HEAD Machine screw, 8-32 X 3/8"	6	2.00
7672	FLAT HEAD Socket screw, 4-40 X 7/8"	6	2.00
7738	SOCKET HEAD Cap screw, 4-40 X 7/8"	2	1.00

non-standard discount item. **net or short discount item.

ASSOCIATED ELECTRICS RC10GT CATALOG

RICHARD SAXTON WINS THE 1998 NORRCATRUCK WORLD CUP WITH HIS RC10GT!!

CHASSIS PARTS

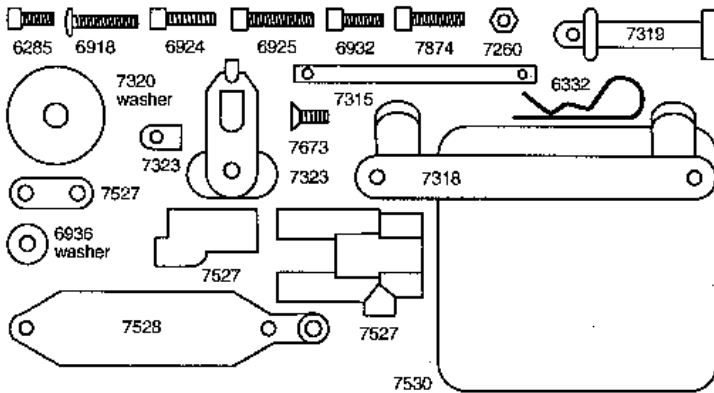
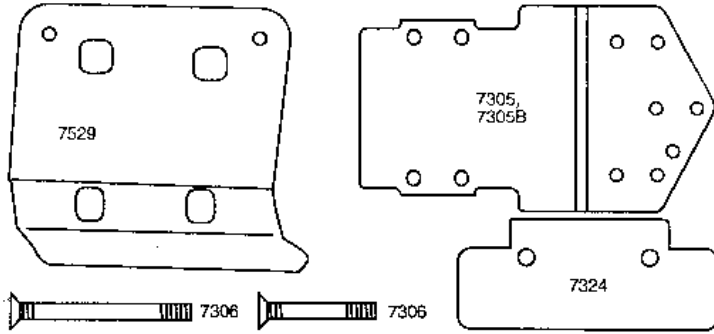

7525	GAS TRUCK TUB CHASSIS, aluminum, black anodized	1	36.00
7525B	NEW! FACTORY TEAM BLUE GAS TRUCK TUB CHASSIS, aluminum	1	40.00
6312	CLEAR CHASSIS PROTECTIVE SHEET to protect the chassis finish	1	8.50
7305	NOSE PLATE, black anodized	1	9.00
7305B	NEW! FACTORY TEAM BLUE NOSE PLATE	1	11.00
7306	TRUCK NOSE PLATE SCREW SET	1	2.00
7315	NOSE BRACE TUBES, black anodized, with screws	pr	5.50
7318	FRONT BODY MOUNT BRACE	1	2.50
7319	FRONT BODY MOUNTS	pr	1.50
7320	NYLON WASHERS, BODY MOUNT, large	4	.75
7323	REAR BODY MOUNTS with screws	pr	3.00
6332	HOOD PINS	6	.75
7324	FRONT BUMPER, nylon	1	2.50
7527	SERVO MOUNTS, gas truck	2pr	2.50
7528	ANTENNA/RECEIVER MOUNT	1	2.00
7529	REAR BUMPER, gas truck	1	3.50
7530	FOAM PAD, for mounting receiver battery pack	1	1.50
9180	SERVO HORNS, molded (1 ea. Airtronics, Futaba, or Jrpropo, Hitec)	1	2.50
6727	NEW! SERVO TAPE STRIP, 1.5 x 6". Replaces #6726 roll.	2	2.00
6285	SOCKET HEAD Cap screw, 4-40 X 1/4", steel	12	2.00
6918	BUTTON HEAD Cap screw, 4-40 X 5/16"	6	2.00
6924	SOCKET HEAD Cap screw, 4-40 X 3/8"	6	2.00
6925	SOCKET HEAD Cap screw, 4-40 X 1/2"	6	2.00
6932	SOCKET HEAD Cap screw, 4-40 X 5/16"	6	2.00
6936	ALUMINUM WASHER, #4	10	1.00
7260	THIN PLAIN NUT, 4-40	12	2.00

REAR SUSPENSION

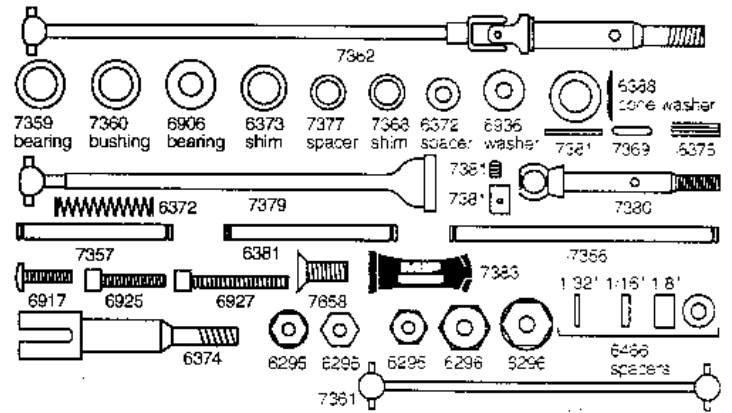
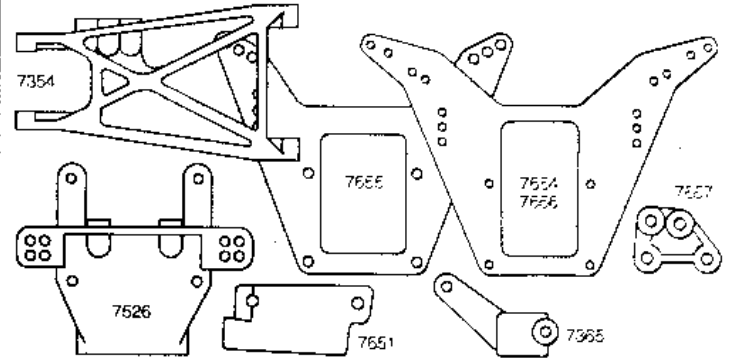

7673	FLAT HEAD Socket screw, 4-40 X 5/16"	6	2.00
7874	SOCKET HEAD Cap screw, 4-40 X 7/16	8	2.50
6372	DOGBONE SPRINGS & SPACERS	4	.75
6373	REAR AXLE SHIMS, 1/4" ID X .010" thick, for #7362 axles	14	1.50
6374	REAR STUB AXLE with roll pin. WARNING! only fits #7800 or #7802 rear wheels	1	5.00
6375	ROLL PIN for stub axle. Fits #6374 or 7362 rear axles	6	.75
6381	HINGE PIN, rear, outer. Fits #6355 or #7354 rear A-arms	2	2.50
6388	CONE WASHER, 1/4" x .400 x .006	4	1.00
7354	TRUCK REAR A-ARMS, new design, black composite material (requires use of #6381 hinge pin)	pr	7.00
7356	REAR A-ARM HINGE PIN, inner; clips, 2.084"	pr	3.00
7357	REAR A-ARM HINGE PIN, outer; clips, 1.205". Only fits original #7355 rear A-arm (#7355 A-arm has been discontinued)	pr	2.50
7359	BALL BEARINGS, 1/4" x 3/8" unflanged, for #6374 or 7362 rear axles	pr	15.00
7360	BUSHING, 1/4 X 3/8" unflanged, for #6374 or 7362 rear axles.	4	2.00
7361	DOGBONE (rear half shaft)	1	7.00
7362	TRUCK UNIVERSALS. WARNING! only fits #7800 or #7802 rear wheels. Uses #7359 bearing.	pr	35.00
7379	MIP CVD BONE, for T2/T3 or GT	1	11.50
7380	MIP CVD AXLE, for T2/T3 or GT	1	8.00
7381	MIP CVD REBUILD KIT, for two axles	set	8.50
7383	MIP CVD'S, new re-build able universal axles. (replaces #7367 axles). Fits T2/T3 & GT	pr	35.50
7368	3/16" I.D. X .010" REAR AXLE SHIMS, fits MIP CVD's and #7367 axles.	14	1.50

7369	1/16" REAR AXLE ROLL PINS, fits MIP CVD's and #7367 axles.	4	1.00
7377	REAR AXLE BEARING SPACER, aluminum (fits only the #7367 rear axle and MIP CVD's)	2	1.50
7365	REAR HUB CARRIERS, 0 deg. toe-in per side	pr	3.50
7526	REAR BULKHEAD, gas truck	1	3.00
7650	REAR SUSPENSION KIT COMPLETE, gas truck	1	37.00
7651	REAR SUSPENSION MOUNTS, gas truck, 3 deg. toe-in per side	pr	2.00
7654	RACING REAR SHOCK STRUT, composite (standard in kits from July '96) Only fits new #6134 GT II body.	1	7.00
7656	RACING REAR SHOCK STRUT, Carbon Fiber composite. Only fits new #6134 GT II body.	1	17.00
7657	REAR SHOCK MOUNTS, nylon	2	2.00
6466	SHOCK DOWNSTOPS, (travel limiters), 4 ea. of 3 sizes 1/8" (.125"), 1/16" (.062") and 1/32" (.031").	set	1.50
7658	FLAT HEAD Machine screw, 8-32 X 3/8", black (for mounting rear bulkhead and suspension mounts to chassis on gas truck)	6	2.00
6295	4-40 NUTS, 6 each, plain nut, nylon & steel locknuts	18	2.00
6296	8-32 LOCKNUTS, 6 each, Alum. locknuts, nylon locknuts	12	3.00
6906	3/16" X 3/8" BALL BEARING, unflanged. For #7367 axles and MIP CVD's	pr	13.00
6917	BUTTON HEAD Socket screw, 4-40 X 3/8"	6	2.00
6925	SOCKET HEAD Cap screw, 4-40 X 1/2"	6	2.00
6927	SOCKET HEAD Cap screw, 4-40 X 3/4"	6	2.00
6936	ALUMINUM WASHER, #4	10	1.00

GAS TRUCK STEALTH TRANSMISSION

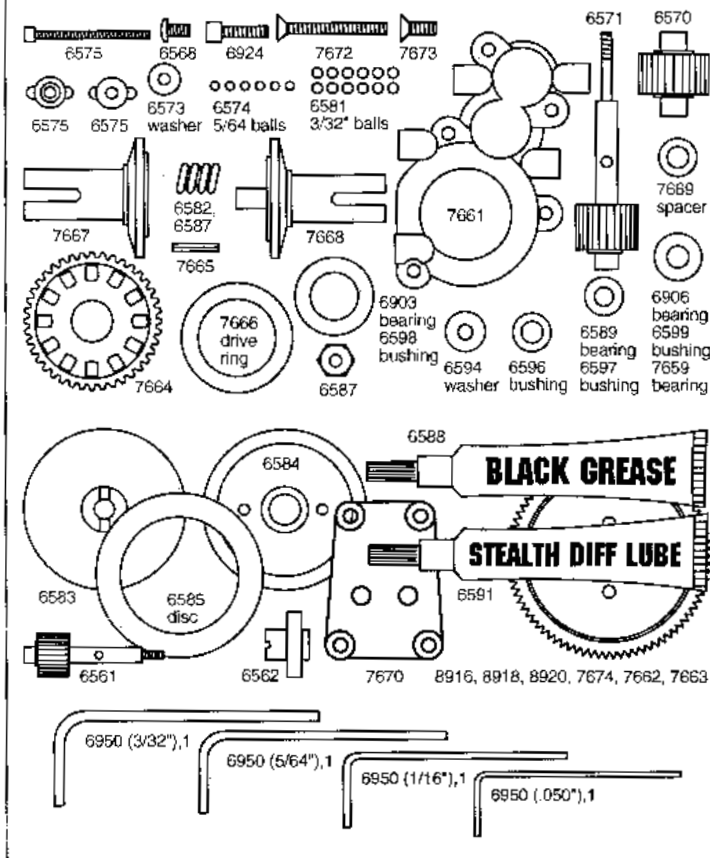

6563	STEALTH TRANSMISSION BALL BEARING SET Eight bearings and one bushing	1	52.00
7661	TRANSMISSION CASE, gas truck	1	6.00
6568	SPUR GEAR SCREWS	4	1.50
6570	IDLER SHAFT & GEAR SET	set	3.50
7669	ECONOMY BEARINGS, to support gas truck idler shaft	2	7.50
6571	DRIVE GEAR/SHAFT ASSEMBLY, roll pin	1	9.00
7665	DRIVE SHAFT ROLL PIN, gas truck	6	1.00
7669	DRIVE SHAFT SPACER	6	2.00
6573	DIFF THRUST WASHER	2	3.00
6574	PRECISION THRUST BALLS, 5/64"	6	2.00
6575	DIFF THRUST BOLT, Thrust Bearing Cover, Dogbone Spacers & Locking T-nut	set	2.00
7667	DIFF OUTDRIVE HUB, right, 2.60:1 Only fits RC10GT & RC10T2	1	7.50
7668	DIFF OUTDRIVE HUB, left, 2.60:1 Only fits RC10GT & RC10T2	1	7.50
7666	DIFF DRIVE RINGS, 2.60:1 Only fits RC10GT & RC10T2	2	1.50
7664	DIFF GEAR, 2.60:1 Only fits RC10GT & RC10T2	1	2.50
7670	TRANSMISSION BRACE, gas truck	1	2.00
6581	CARBIDE DIFF BALLS, large 3/32"	12	12.00
6582	DIFF THRUST SPRING	1	1.50
6583	TORQUE CONTROL HUB, inner	1	7.50
6584	TORQUE CONTROL HUB, outer	1	7.50
9251	T3/B3/GT TORQUE CONTROL HUB, inner	1	7.50
9252	T3/B3/GT TORQUE CONTROL HUB, outer (uses #6599 3/16" x 3/8" bushing)	1	7.50
6585	RULON CLUTCH DISK	1	3.00
9253	T3/B3/GT CLUTCH DISC	1	3.00
6594	THRUST BEARING WASHER, replaces #6586 thrust bearing	set	2.00
6587	TORQUE CONTROL SPRING & LOCKNUT	set	1.50
8916	56 TOOTH 32 PITCH SPUR GEAR	1	4.00
8918	58 TOOTH 32 PITCH SPUR GEAR	1	4.00
8920	60 TOOTH 32 PITCH SPUR GEAR	1	4.00
7674	NEW! 62 TOOTH 32 PITCH SPUR GEAR	1	4.00
7662	64 TOOTH, 32 PITCH SPUR GEAR gas truck	1	4.00
7663	66 TOOTH, 32 PITCH SPUR GEAR gas truck	1	4.00
6588	BLACK GREASE	1	2.50
6589	5/32" x 5/16" BALL BEARING, unflanged	pr	13.00
6591	STEALTH DIFF LUBE	1	2.50
6592	ALLEN WRENCH SET	set	2.50
6561	NEW! DIRECT DRIVE SHAFT (fixed drive gear shaft)	1	9.00
6562	NEW! GEAR ADAPTER, MOLDED, for direct drive shaft	1	3.50
6595	COMPLETE BUSHING SET FOR STEALTH TRANSMISSION	9	5.00
6596	3/16" x 5/16" BUSHING, unflanged	2	1.00
6597	5/32" x 5/16" BUSHING, unflanged	2	1.00
6598	3/8" x 5/8" BUSHING, unflanged	2	1.50
6599	3/16" x 3/8" BUSHING, unflanged	4	2.00
6903	3/8" x 5/8" BALL BEARING, unflanged, sealed	pr	20.00
6906	3/16" x 3/8" BALL BEARING, unflanged	pr	13.00
6924	SOCKET HEAD Cap screw, 4-40 X 3/8"	6	2.00
7672	FLAT HEAD Socket screw, 4-40 X 7/8" (front transmission mounting screw)	6	2.00
7673	FLAT HEAD Socket screw, 4-40 X 5/16" (rear transmission mounting screw)	6	2.00

non-standard discount item. **net or short discount item.

ASSOCIATED ELECTRICS RC10GT CATALOG

RICHARD SAXTON WINS THE 1998 NORRCATRUCK WORLD CUP WITH HIS RC10GT!!

BRAKE/THROTTLE

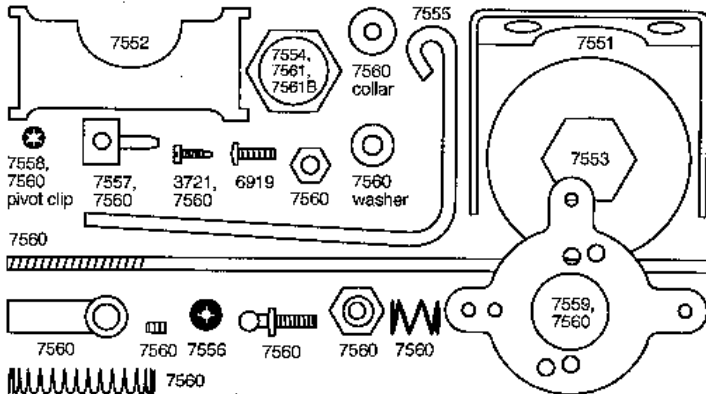

7551	BRAKE BRACKET, plated	1	2.50
7552	BRAKE SHOE, plated	1	1.50
7553	BRAKE DISC, fiber	1	4.00
7554	DISC BRAKE ADAPTER, plastic	1	1.00
7555	DISC BRAKE CAM., steel	1	3.00
7556	BRAKE CAM CLIP (push nut)	6	1.50
7557	THROTTLE PIVOT, aluminum	1	2.00
7558	THROTTLE PIVOT CLIP (push nut)	6	1.50
7559	SERVO HORN ADAPTER, plastic	1	1.50
7560	BRAKE/THROTTLE LINKAGE KIT, complete	1	9.00
7561	DISK BRAKE ADAPTER, aluminum	1	3.50
7561B	NEW! FACTORY TEAM BLUE DISK BRAKE ADAPTER, aluminum	1	5.00
3721	SELF-TAPPING screw, 2-56 X 1/4"	12	1.00
6919	BUTTON HEAD Socket screw, 4-40 X 5/16"	6	2.00

CLUTCH

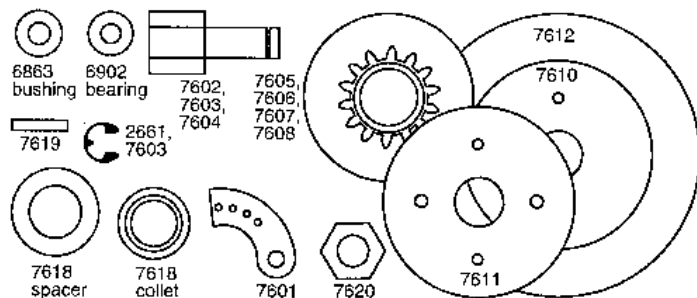

7601	CLUTCH SHOE, Teflon	pr	7.00
7602	CLUTCH NUT for Dynamite engine	1	5.00
7603	CLUTCH NUT (fits Yokomo and new OS Max engines)	1	5.00
7604	CLUTCH NUT, special (fits OS Max crankshafts made before Oct. 1993)	1	5.00
2661	CLUTCH NUT CLIPS	6	.75
7605	15 TOOTH, 32 PITCH CLUTCH BELL, steel. Recommended gear for small, tight, off road tracks.	1	8.00
7606	16 TOOTH, 32 PITCH CLUTCH BELL, steel. Recommended gear for larger off road tracks.	1	8.00
7607	17 TOOTH, 32 PITCH CLUTCH BELL, steel. For use on oval track racing (will not fit pull start engines)	1	8.00
7608	18 TOOTH, 32 PITCH CLUTCH BELL, steel. For use on large oval track racing (will not fit pull start engines). WARNING: May require aftermarket parts	1	8.00

	and modification to truck.		
8902	22 TOOTH, 32 PITCH CLUTCH BELL, steel.	1	8.50
8904	24 TOOTH, 32 PITCH CLUTCH BELL, steel.	1	8.50
6902	BALL BEARING, 3/16 X 5/16", flanged	pr	15.00
6863	BUSHING, 3/16 X 5/16", for two rims	4	1.50
7610	FLYWHEEL, non-pull start engine (Yokomo, Dynamite, OS Max)	1	8.00
7611	RACING FOUR SHOE FLY-WHEEL, requires two #7601 clutch shoe sets, not included	1	10.00
7612	FLYWHEEL, pull start engine (Yokomo, Dynamite, OS Max)	1	8.00
7818	FLYWHEEL COLLET, with spacer shim	1	3.00
7619	FLYWHEEL PIN	2	1.00
7620	SPECIAL CUT OFF NUT, for cutting crankshaft to correct length for clutch nut installation (Yokomo, Dynamite and OS Max)	1	2.50

WHEELS & TIRES

See Associated's Pictorial Catalog or web site for pictures of most wheels and tires

REAR WHEELS & TIRES

7800	REAR WHEEL, 3 piece, with screws. White. (Fits only #6374 or #7362 axles)	pr	7.00
7800B	TRUCK REAR WHEELS, 3 piece, 2.2", black. (Fits only #6374 or #7362 axles)	pr	7.00
7800Y	TRUCK REAR WHEELS, 3 piece, 2.2", fluorescent yellow. (Fits only #6374 or #7362 axles)	pr	7.00
7801	ALUM. SOCKET HEAD Cap screw, 4-40 X 5/8"	8	2.50
7802	REAR WHEEL, one piece, lightweight. White (Fits only #6374 or #7362 axles)	pr	7.00
7802B	TRUCK REAR WHEELS, 1 piece, 2.2", black. (Fits only #6374 or #7362 axles)	pr	7.00
7802Y	TRUCK REAR WHEELS, 1 piece, 2.2", fluorescent yellow. (Fits only #6374 or #7362 axles)	pr	7.00
7803	NEW TRUCK REAR WHEEL, 1 piece, 2.2" white (fits MIP CVD's or #7367 rear axles only.)	pr	7.00
7803B	NEW TRUCK REAR WHEEL, 1 piece, 2.2" black (fits MIP CVD's or #7367 rear axles only.)	pr	7.00
7803Y	NEW TRUCK REAR WHEEL, 1 piece, 2.2" fluorescent yellow (fits MIP CVD's or #7367 rear axles only.)	pr	7.00
7824	REAR TIRE, PROLINE M2 compound, "Bow Tie" design, with foam inserts. 2.2". New standard tire for Truck kits	pr	17.95
7880	TRUCK TIRE INSERT, white	pr	2.00
6926	SOCKET HEAD Cap screw, 4-40 x 5/8"	6	2.00

WIDE FRONT WHEELS & TIRES

7840	WIDE FRONT WHEEL, 3 piece, with screws	pr	7.00
7840B	TRUCK FRONT WHEELS, 3 piece, 2.2", black	pr	7.00
7840Y	TRUCK FRONT WHEELS, 3 piece, 2.2", fluorescent yellow	pr	7.00
7801	ALUM. SOCKET HEAD Cap screw, 4-40 X 5/8"	8	2.50
7842	WIDE FRONT WHEEL, one piece, lightweight	pr	7.00
7842B	TRUCK FRONT WHEELS, 1 piece, 2.2", black	pr	7.00
7842Y	TRUCK FRONT WHEELS, 1 piece, 2.2", fluorescent yellow	pr	7.00
6599	FRONT WHEEL BUSHING, 3/16" x 3/8", unflanged	4	2.00
6926	SOCKET HEAD Cap screw 4-40 x 5/8"	6	2.00
7877	FRONT TIRE, PROLINE M2 compound, "Edge" design, 2.2" w/foam inserts	pr	17.95
6906	3/16" x 3/8" BALL BEARING, unflanged	pr	13.00

BALL BEARINGS

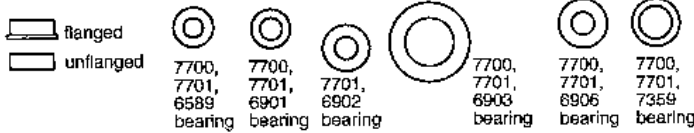

7700	BALL BEARING SET For all kits with 3/16" rear stub axles or universals. (Does not include gas engine clutch ball bearings #6902)	16	95.00
7701	COMPLETE BALL BEARING KIT, for RC10GT with 1/4" rear stub axles or universals (includes gas engine clutch ball bearings #6902)	18	105.00
6589	5/32" X 5/16" BALL BEARING, unflanged	pr	13.00
6901	3/16" X 5/16" BALL BEARING, unflanged	pr	13.00
6902	3/16" X 5/16" BALL BEARING, flanged	pr	15.00
6903	3/8" X 5/8" BALL BEARING, unflanged	pr	20.00
6906	3/16" X 3/8" BALL BEARING, unflanged	pr	13.00
7359	1/4" X 3/8" BALL BEARING, unflanged	pr	15.00

SHOCKS

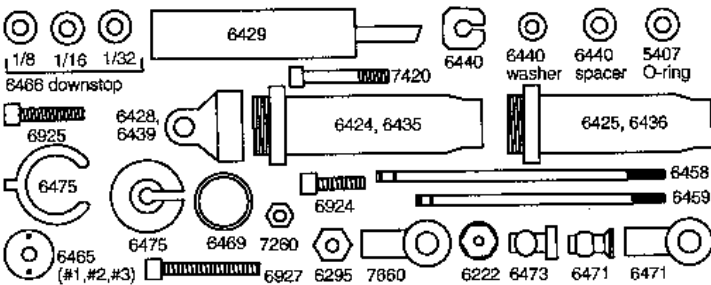

GOLD, STANDARD

6420	SHOCK SET, rear, 1.32, STANDARD	pr	25.00
6421	SHOCK SET, front, 1.02, STANDARD	pr	25.00
6424	SHOCK BODY, rear, 1.32, STANDARD	1	6.75
6425	SHOCK BODY, front, 1.02, STANDARD	1	6.75
6428	END CAP, plastic	1	2.25
6429	SHOCK ASSEMBLY TOOL	1	1.00

GRAY, RACING. HARD ANODIZED, TEFLON SEALED

6431	SHOCK SET, rear, 1.32, RACING	pr	30.00
6432	SHOCK SET, front, 1.02, RACING	pr	30.00
6435	SHOCK BODY, rear, 1.32, RACING	1	8.50
6436	SHOCK BODY, front, 1.02, RACING	1	8.50
6439	SHOCK END CAP, aluminum black anodized	1	3.00
6429	SHOCK ASSEMBLY TOOL	1	1.00

PARTS FOR ALL SHOCKS

5407	RED SILICONE "O" RINGS only, as used in rebuild kits #6440	8	2.00
6440	REBUILD KIT, for for 4 shocks	set	4.00
6458	SHOCK SHAFT 1.32 Stroke	1	3.00

PRODUCT SPOTLIGHT

ASSOCIATED'S UNOBTAINIUM SHOCK SHAFTS

Improved shock performance and shaft life comes with the Associated Unobtainium coated shock shafts. The highly advanced Titanium CARBOnitride coating has a 30% harder finish and 25% less friction than the coating being used by other manufacturers. This results in smoother shock performance, increased shaft and seal life, and increased time between rebuilds that the serious racer and hobbyist has been looking for.

6416	UNOBTAINIUM SHOCK SHAFT 1.32 Stroke, rear	1	6.00
6417	UNOBTAINIUM SHOCK SHAFT 1.02 Stroke, front	1	6.00
6459	SHOCK SHAFT 1.02 Stroke	1	3.00
6464	PISTONS, all 0.4 bore shocks	4	3.00
6465	SHOCK PISTON, 4 each of #1, #2 & #3 to adjust dampening	12	3.00
6466	SHOCK DOWNSTOPS, (travel limiters), 4 ea. of 3 sizes 1/8" (.125"), 1/16" (.062") and 1/32" (.031").	set	1.50
6469	O-RINGS, shock end caps-to-body seals	4	1.50
6470	MOUNTING KIT, with rod ends, for 2 shocks	1	4.50
6471	ROD ENDS for 2 shocks, .230 ball	pr	3.00
6473	SHOCK BUSHINGS	4	1.00
6475	NEW! SPRING CUPS AND PRELOAD CLIPS	1	5.00
7217	SHOCK/TURNBUCKLE ROD END, nylon w/plastic pivot ball (replaces #7660 w/steel ball end)	2	3.00
7660	REAR SHOCK/TURNBUCKLE steel ball end with nylon eyelet	pr	3.00
6222	SELF-THREADING NYLON LOCKNUT, for #6220 axles	8	2.00
6295	4-40 NUTS, 6 each, plain nut, nylon & steel locknuts	18	2.00
6924	SOCKET HEAD Cap screw, 4-40 X 3/8"	6	2.00
6925	SOCKET HEAD Cap screw, 4-40 X 1/2"	6	2.00
6927	SOCKET HEAD Cap screw, 4-40 X 3/4"	6	2.00
7260	THIN NUTS, 4-40, for ball ends	12	2.00
7420	SOCKET HEAD Cap screw, 4-40 x 5/8", special (truck front lower shock screw). Only fits original style truck front A-arms	2	1.00

SHOCK OILS

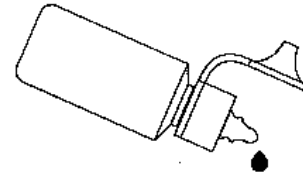

5410	SHOCK OIL, 140 wt. 1 ounce bottle	1	1.25
5412	SHOCK OIL, 50 wt. 1 ounce bottle	1	1.25
5413	SHOCK OIL, 40 wt. 1 ounce bottle	1	1.25
5414	SHOCK OIL, 30 wt. 1 ounce bottle	1	1.25
5415	SHOCK OIL, 20 wt. 1 ounce bottle	1	1.25
5416	SHOCK OIL, 10 wt. 1 ounce bottle	1	1.25
5420	SILICONE SHOCK OIL, 10 wt. 2 ounce bottle	1	3.50
5427	SILICONE SHOCK OIL, 15 wt. 2 ounce bottle	1	3.50
5421	SILICONE SHOCK OIL, 20 wt. 2 ounce bottle	1	3.50
5428	SILICONE SHOCK OIL, 25 wt. 2 ounce bottle	1	3.50
5422	SILICONE SHOCK OIL, 30 wt. 2 ounce bottle	1	3.50
5429	SILICONE SHOCK OIL, 35 wt. 2 ounce bottle	1	3.50
5423	SILICONE SHOCK OIL, 40 wt. 2 ounce bottle	1	3.50
5425	SILICONE SHOCK OIL, 80 wt. 2 ounce bottle	1	3.50

PRECISION RACING SPRINGS



Order of springs from top to bottom: soft to firm

7426	TRUCK FRONT RACING SPRING, black	pr	2.50
7427	TRUCK FRONT RACING SPRING, green	pr	2.50
7428	TRUCK FRONT RACING SPRING, silver	pr	2.50
7429	TRUCK FRONT RACING SPRING, blue	pr	2.50

7425	TRUCK FRONT RACING SPRING, gold	pr	2.50
7430	TRUCK FRONT RACING SPRING, red	pr	2.50
6481	TRUCK & BUGGY REAR RACING SPRING, black	pr	2.50
6480	TRUCK & BUGGY REAR RACING SPRING, green	pr	2.50
6478	TRUCK & BUGGY REAR RACING SPRING, silver	pr	2.50
7434	TRUCK & BUGGY REAR RACING SPRING, blue	pr	2.50
7435	TRUCK & BUGGY REAR RACING SPRING, gold	pr	2.50
7436	TRUCK & BUGGY REAR RACING SPRING, red	pr	2.50

ENGINE MOUNT PARTS

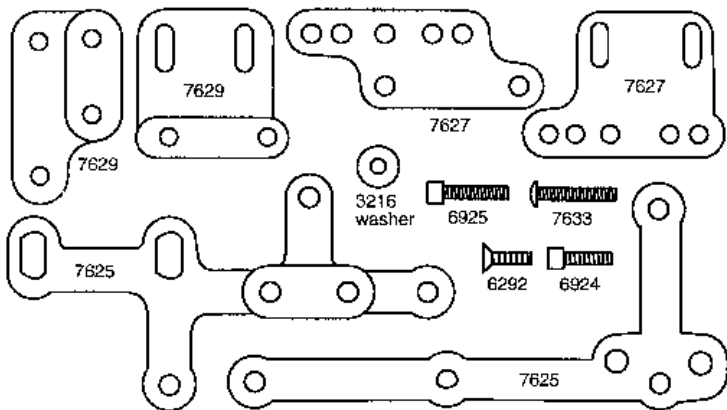

7625	CHASSIS ENGINE MOUNT, black	pr	8.00
7627	ENGINE MOUNT ADAPTER, for non-pull start engine	pr	11.00
7629	ENGINE MOUNT ADAPTER, for pull start engine	pr	8.00
3216	WASHER, #4, steel, (gold colored)	12	1.00
6292	FLAT HEAD Socket screw, 4-40 X 3/8"	6	2.00
6924	SOCKET HEAD Cap screw, 4-40 X 3/8"	6	2.00
6925	SOCKET HEAD Cap screw, 4-40 X 1/2"	6	2.00
7633	BUTTON HEAD Socket screw, 4-40 X 5/8" (rear engine mount adapter mounting screw)	6	2.00

ENGINE ACCESSORIES

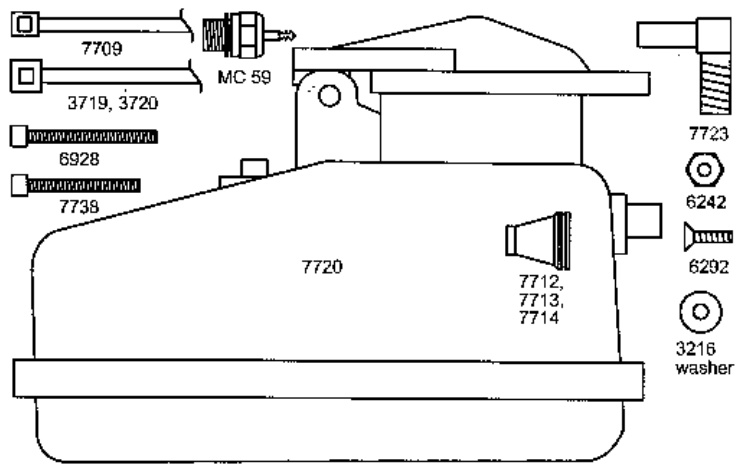
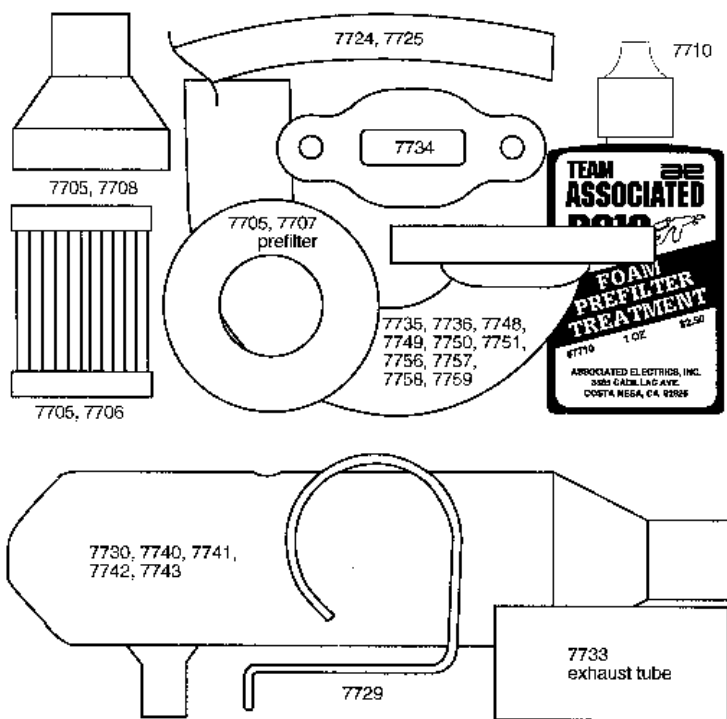

MC 59	McCOY GLOW PLUG. For .12 engines	1	3.65**
7705	AIR FILTER KIT, consists of paper filter, foam prefilter, and air filter boot	1	7.50
7706	PAPER AIR FILTER ELEMENT	1	3.00
7707	FOAM PREFILTER ELEMENT	4	2.50
7708	AIR FILTER BOOT	1	3.00
7710	FOAM FILTER TREATMENT	1 oz.	2.50

PRODUCT SPOTLIGHT

CARBURETOR RESTRICTOR FOR THE OS MAX
 Associated's carburetor restrictor for the OS Max engine is designed to make your car easier to drive with smoother acceleration. Three hole sizes are available to help you find just the right handling you need.

7712	CARBURETOR RESTRICTOR for the OS Max engine is designed to make your car easier to drive with smoother acceleration, .190", silver	1	3.50
7713	CARBURETOR RESTRICTOR, .180", blue	1	3.50
7714	CARBURETOR RESTRICTOR, .170", black	1	3.50
3719	NYLON WIRE TIES, 6" heavy duty	12	2.00
3720	NYLON TIES, 8", light duty for receiver	12	2.00
7709	NYLON WIRE TIES, 4" light duty	12	1.25
7720	FUEL TANK, plastic, 75cc	1	14.00
7723	FUEL TANK FITTING	1	4.00
7724	FUEL TUBING, 15"	1	2.00
7725	FUEL TUBING, 3 feet	1	4.00
7729	MUFFLER BRACKET	1	3.00
7730	MUFFLER, TUNED PIPE	1	21.00
7740	MUFFLER, black anodized	1	37.00
7741	MUFFLER, polished (chrome look)	1	37.00
7742	MUFFLER, blue anodized	1	37.00
7743	MUFFLER, purple anodized	1	37.00
7733	SILICONE EXHAUST TUBING, 2"	1	2.00
7734	GASKET, exhaust manifold	3	2.00
7735	EXHAUST MANIFOLD, for pull start engine (Yokomo, Dynamite and OS Max)	1	12.50
7736	EXHAUST MANIFOLD, for non-pull start engine (Yokomo, Dynamite and OS Max)	1	12.50
7748	MANIFOLD, PULL START, black anodized	1	20.00
7749	MANIFOLD, PULL START, polished (chrome look)	1	20.00
7750	MANIFOLD, PULL START, blue anodized	1	20.00
7751	MANIFOLD, PULL START, purple anodized	1	20.00
7756	MANIFOLD, NON PULL START, black anodized	1	20.00
7757	MANIFOLD, NON PULL START, polished (chrome look)	1	20.00
7758	MANIFOLD, NON PULL START, blue anodized	1	20.00

non-standard discount item. **net or short discount item.

7759	MANIFOLD, NON PULL START, purple anodized	1	20.00
3216	WASHER, #4	12	1.00
6242	FRONT WHEEL LOCKNUTS, 4-40	6	1.00
6292	FLAT HEAD Socket screw, 4-40 X 3/8"	6	2.00
6928	SOCKET HEAD Cap screw, 4-40 X 1" (for Yokomo exhaust manifold installation)	6	2.00
7738	SOCKET HEAD Cap screw, 4-40 X 7/8" (for OS Max and Dynamite exhaust manifold installation)	2	1.00

MISCELLANEOUS

The following fasteners include parts not standard on the RC10GT. These are included to meet any needs for custom installations.

LIGHTWEIGHT ALUMINUM & NYLON HARDWARE



7675	LIGHTWEIGHT ALUMINUM SCREW SET, for all RC10GT models (70 screws)	1	17.00
3325	ALUM. FLAT HEAD Machine screw, 8-32 X 1 1/4"	6	1.50
6280	ALUMINUM FLAT HEAD Machine screw, 8-32 X 1/2"	16	2.00
6281	ALUM. FLAT HEAD Machine screw 8-32 X 7/8"	6	2.00
7658	FLAT HEAD Machine screw, 8-32 X 3/8"	6	2.00
6284	ALUM. SOCKET HEAD Cap screw, 4-40 X 1/4"	12	4.00
4145	ALUM. SOCKET HEAD Cap screw, 4-40 X 5/16"	4	1.50
7873	ALUM. SOCKET HEAD Cap screw 4-40 x 7/16"	8	2.50
7801	ALUM. SOCKET HEAD Cap screw, 4-40 X 5/8"	8	2.50
7801	ALUM. SOCKET HEAD Cap screw, 4-40 X 5/8"	8	2.50
6939	ALUM. FLAT HEAD Socket, 4-40 X 1/4"	6	2.00
6933	ALUM. FLAT HEAD Socket, 4-40 X 5/16"	6	2.00
6934	ALUM. FLAT HEAD Socket, 4-40 X 3/8"	6	2.00
6938	ALUM. FLAT HEAD Socket, 4-40 X 1/2"	6	2.00
6935	ALUM. SOCKET HEAD Cap screw, 4-40 X 1"	4	3.00
6936	ALUMINUM WASHER, #4	10	1.00
3323	WASHER, #8	12	1.50
3438	ALUMINUM LOCKNUT, 8-32	3	1.50
4184	NYLON LOCKNUT, 4-40	6	1.00
4185	NYLON LOCKNUT, 8-32	6	1.00
4449	ALUMINUM LOCKNUT, 4-40, lightweight, small	5	2.50
6222	SELF-THREADING NYLON LOCKNUT, for #6220 axles	8	2.00
6937	ALUMINUM LOCKNUT, 4-40	6	3.00

STANDARD SCREWS

3216	WASHER, #4	12	1.00
7260	THIN NUTS, 4-40, for ball ends	12	2.00
6295	4-40 NUTS, 6 each, plain nut, nylon & steel locknuts	18	2.00
6296	8-32 LOCKNUTS, 6 each, Alum. locknuts, nylon locknuts	12	3.00
3721	SELF-TAPPING SCREW, 2-56 X 1/4"	12	1.00
6951	SET SCREWS & WRENCH, 4-40 X 1/8"	6	2.50
6242	FRONT WHEEL LOCKNUT, 4-40	6	1.00
8920	BUTTON HEAD Socket screw, 4-40 X 3/16"	6	2.00
6288	BUTTON HEAD Socket screw, 4-40 X 1/4"	6	2.00
6918	BUTTON HEAD Cap screw, 4-40 X 5/16"	6	2.00
6919	BUTTON HEAD Socket screw, 4-40 X 5/16"	6	2.00
6917	BUTTON HEAD Socket screw, 4-40 X 3/8"	6	2.00
7633	BUTTON HEAD Socket Screw, 4-40 x 5/8"	6	2.00
7413	BUTTON HEAD Socket Screw, 4-40 x 3/4"	6	2.00
6931	FLAT HEAD Machine screw, 8-32 X 1/4"	6	1.00
6291	FLAT HEAD Socket screw, 4-40 X 1/4"	6	2.00
7673	FLAT HEAD Socket Screw, 4-40 x 5/16"	6	2.00

6292	FLAT HEAD Socket screw, 4-40 X 3/8"	6	2.00
6922	FLAT HEAD Socket screw, 4-40 X 1/2"	6	2.00
4519	FLAT HEAD Socket screw, 4-40 x 9/16"	6	2.00
6923	FLAT HEAD Socket screw, 4-40 X 3/4"	6	2.00
7672	FLAT HEAD Socket Screw, 4-40 x 7/8"	6	2.00
6285	SOCKET HEAD Cap screw, 4-40 X 1/4"	12	2.00
6932	SOCKET HEAD Cap screw, 4-40 X 5/16"	6	2.00
6924	SOCKET HEAD Cap screw, 4-40 X 3/8"	6	2.00
6929	SOCKET HEAD Cap screw, 4-40 X 3/8" with hole	4	2.50
7874	SOCKET HEAD Cap screw, 4-40 x 7/16"	8	2.50
6925	SOCKET HEAD Cap screw, 4-40 X 1/2"	6	2.00
6926	SOCKET HEAD Cap screw, 4-40 X 5/8"	6	2.00
6930	SOCKET HEAD Cap screw, 4-40 X 3/4", special	6	2.00
6927	SOCKET HEAD Cap screw, 4-40 X 3/4"	6	2.00
6860	SOCKET HEAD Cap screw, 4-40 X 7/8" (for OS Max and Dynamite exhaust manifold installation)	2	1.00
6928	SOCKET HEAD Cap screw, 4-40 X 1" (for Yokomo exhaust manifold installation)	6	2.00

TOOLS

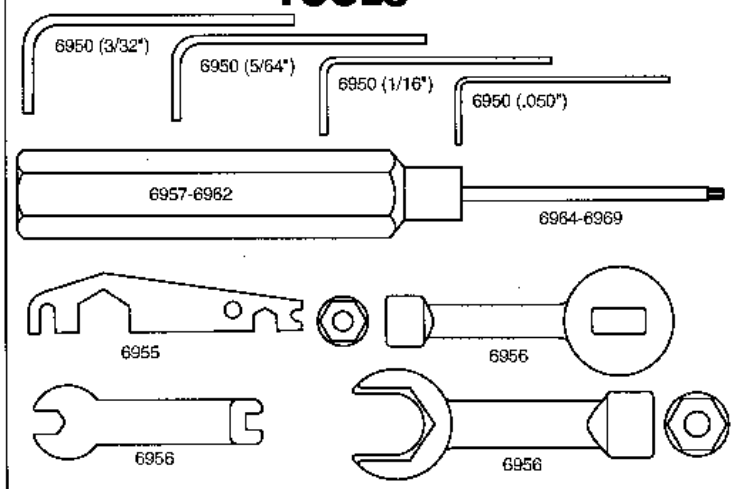

SP-78	NUT DRIVER, 5/16" (glow plug wrench)	1	7.50*
SP-86	NUT DRIVER, 3/16"	1	7.50*

PRODUCT SPOTLIGHT

ASSOCIATED TEAM TOOL KIT

Associated Electrics just made the job of adjusting and maintaining your R/C car a little easier by releasing their new Team Tools molded tool set. This three-piece, multi-use molded tool set features six different functions: a steering turnbuckle adjustment wrench, a 3/16" 10L camber adjustment turnbuckle wrench, two different size sockets to fit both front and rear wheel nuts, and tow handy shock tools; a wrench perfectly sized to fit Associated shock caps, and a wrench to hold your shock body securely during shock building or maintenance. No more scarring your shock's finish with ill-fitting pliers! #6956.

6956	ASSOCIATED MOLDED TOOL SET. Wrenches to install 11/32", 1/4", and 3/16" nuts, adjust 1/8" and 3/16" turnbuckles, and install and remove Associated shock caps.	Set	4.50
6957	.050" ALLEN DRIVER, clear anodized alum. hex handle, precision ground replaceable tip	1	10.50
6958	1/16" ALLEN DRIVER, black anodized alum. hex handle, precision ground replaceable tip	1	10.50
6959	5/64" ALLEN DRIVER, blue anodized alum. hex handle, precision ground replaceable tip	1	10.50
6960	3/32" ALLEN DRIVER, gold anodized alum. hex handle, precision ground replaceable tip	1	10.50

non-standard discount item. **net or short discount item.

6961	2.5mm ALLEN DRIVER, green anodized alum. hex handle, precision ground replaceable tip	1	10.50
6962	1.5mm ALLEN DRIVER, purple anodized alum. hex handle, precision ground replaceable tip	1	10.50
6964	.050" REPLACEMENT TIP, precision ground	1	5.50
6965	1/16" REPLACEMENT TIP, precision ground	1	5.50
6966	5/64" REPLACEMENT TIP, precision ground	1	5.50
6967	3/32" REPLACEMENT TIP, precision ground	1	5.50
6968	2.5mm REPLACEMENT TIP, precision ground	1	5.50
6969	1.5mm REPLACEMENT TIP, precision ground	1	5.50
6950	ALLEN WRENCH SET, 3/32", 1/16", .050, .035	set	2.50
6955	SHOCK WRENCH SET (and ball joint splitter)	1	2.50

TRUCK & EQUIPMENT CARRIER

SP-100	ASSOCIATED CAR CARRIER BOX, cardboard outer box w/locking end flap (fits inside #SP-415 carrier bag), includes three 24" X 12" X 6" inner boxes. Due to its large size, an additional \$15.00 must be added to UPS standard shipping charges.	1	15.00**
SP-101	INNER BOXES 24" x 12" x 6." Replacement cardboard inner boxes for #SP-100 car carrier box	3	5.25**
SP-415	ASSOCIATED CAR CARRIER BAG, black nylon w/brass zipper. Fits #SP-100 car carrier box	1	39.95**

APPAREL

SP-37 XXL	REEDY FIRE HAWK T-SHIRT. Fluorescent orange "Fire Hawk" and white Reedy logo on black T-shirt. Printed both sides. XXL size only.	1	13.00*
SP-41	RC10B3 '97 WORLDS T-SHIRT. Specify M, L, XL	1	13.00*
SP-41 XXL	RC10B3 '97 WORLDS T-SHIRT. Size XXL	1	15.00*
SP-42	NEW! RC10T3/GT T-SHIRT. Specify M, L, XL	1	13.00*
SP-42 XXL	NEW! RC10T3/GT T-SHIRT. Size XXL	1	15.00*

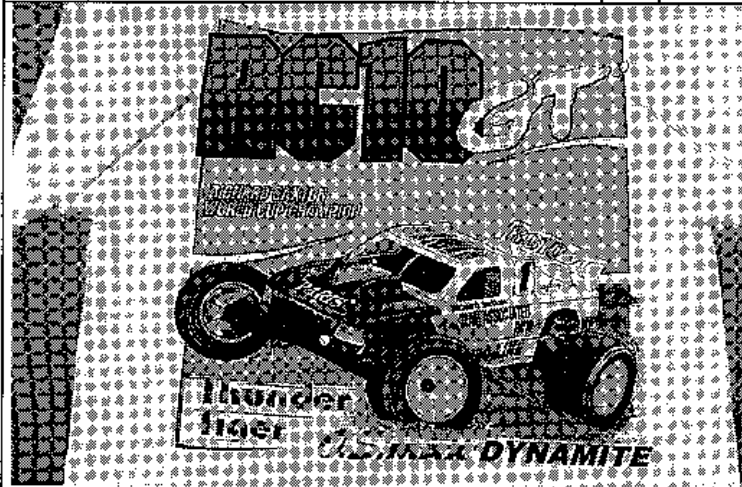

Mark Pavidis' RC10T3 on front,

Richard Saxton's RC10GT on back, pictured above (#SP-42).

SP-410	TEAM ASSOCIATED JACKET, red, white & blue. Fully lined. Specify M, L, XL, XXL, XXXL	1	59.95**
SP-406	NEW! FACTORY TEAM CAP, blue. Latest cool low crown style to complement your car! Heavy brushed twill cap with contrasting stitch, and are buckle back adjustable. One size fits all.	1	15.95*
SP-407	NEW! FACTORY TEAM CAP, black. Latest cool low crown style to complement your car! Heavy brushed twill cap with contrasting stitch, and are buckle back adjustable. One size fits all.	1	15.95*



Caps are available in black (#SP-407) and dark blue (#SP-406).

VIDEOS

7790	VHS VIDEO, <i>How to Tune Your RC10GT Engine</i>	1	9.95
7790P	PAL VIDEO, <i>How to Tune Your RC10GT Engine</i> in international PAL format	1	9.95
6977	VHS VIDEO, <i>R/C Car Racing '95</i> . Highlights from some of 1995's greatest races!	1	19.95
6979	VHS VIDEO, <i>R/C Car Racing '97</i> . Highlights from some of 1997's greatest races! (Note: 1997 Off Road IFMAR Worlds not included due to contractual limitations.) Approx. 110 min.	1	19.95
6979P	PAL VIDEO, <i>R/C Car Racing '97</i> . In international PAL format.	1	19.95

OTHER

SP-200	NEW! OFF ROAD MOUSEPAD with B3 and T3 action shots.	1	9.95
--------	--	---	------

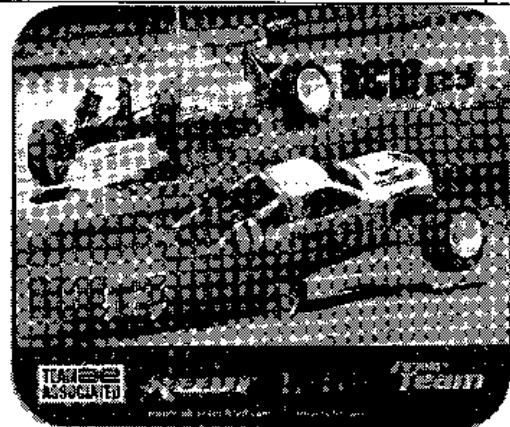

This full color Mousepad (#SP-200) shows off your favorite off road kit!

See this hobby dealer for Associated products:

FACTORY Team PARTS

for the RC10GT truck

TEAM
ASSOCIATED

#7305B
GT NOSEPLATE

#7742
BLUE
TUNED PIPE

#7741
CHROME
TUNED PIPE

#7743
PURPLE
TUNED PIPE

#7740
BLACK
TUNED PIPE

#7525B
GT CHASSIS

#7675
LIGHTWEIGHT
SCREW KIT

#1280
TURNBUCKLE KIT

#7751 (for pull start)
#7759 (non pull start)

#7741 (for pull start)
#7749 (non pull start)

#7750 (for pull start)
#7758 (non pull start)

#7748 (for pull start)
#7756 (non pull start)