



• Nitro TC3 series • 1:10 scale • Nitro Powered • On Road Touring Car •

Nitro TC3 Team

Nitro TC3 RTR



NITRO TC3

Team: side exhaust (shown) or rear exhaust

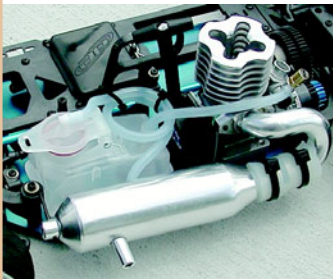

(engine not included)

Team: 2-speed

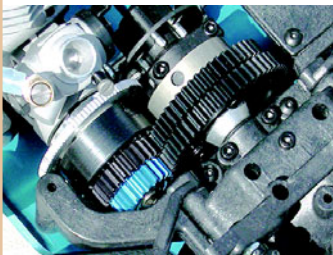

shaft drive

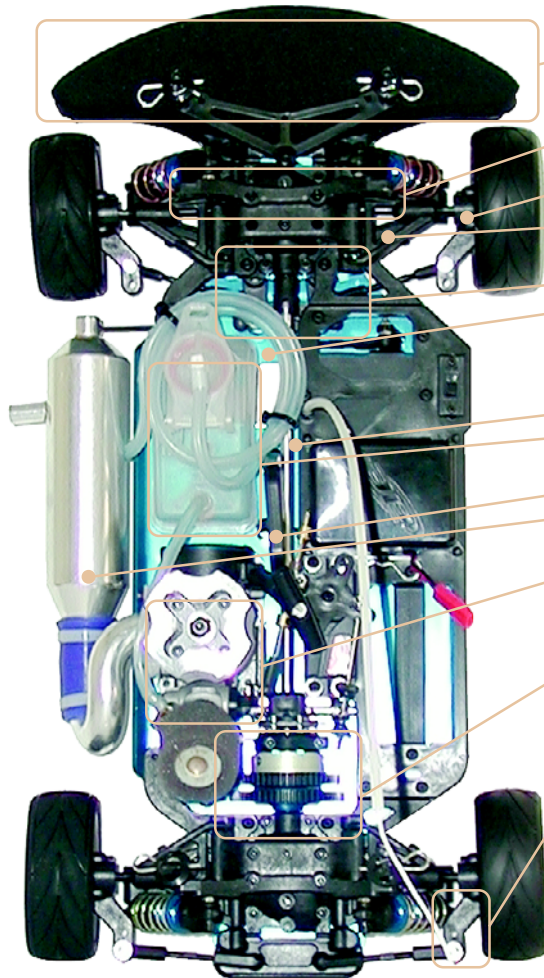

Features

- Rubber-mounted floating bumper with extra wide Kydex base.
- Same shock towers on front and rear.
- Symmetrical hub carriers, front and rear.
- Symmetrical A-arms, front and rear.
- Optimized Ackerman.
- Chassis is made from 0.10" (2.6mm) thick aircraft aluminum for strength.
- Durable shaft drive.
- Reversed quick-fill fuel tank.
- Easy-carry handle.
- Rear or side exhaust engine compatible.
- .12 size pull start side exhaust ABC engine (RTR only).
- Shoe type 2-speed transmission. (single speed on RTR.)
- Pivot ball suspension uses finely-threaded pivot balls.
- Kimbrough spur

NITRO TC3 RTR

RTR: Prepainted bodies



RTR: radio system



RTR: .12 pull start engine



Photo shows optional items not included in kits

• SEE WEB SITE FOR MORE DETAILS AND HOPUPS • www.RC10.com • www.TeamAssociated.com •

FEATURE COMPARISONS

Feature	Pull Start Kit, side exhaust	Non Pull Start Kit, rear exhaust	RTR Pull Start
body	none	none	repainted
shocks	threaded blue VCS Macro	threaded blue VCS Macro	composite bodies
wheels/tires	Pro-Line V-Rage w/Gumby wheels	Pro-Line V-Rage w/Gumby wheels	mounted wheels & tires
driveshafts	aluminum MIP CVD's	aluminum MIP CVD's	uni-axle design
starter	pull start engine mounts	non pull engine mounts	.12 pull start engine
turnbuckles	steel	steel	steel
bearings	rubber-sealed ball bearings	rubber-sealed ball bearings	rubber-sealed ball bearings
engine	none	none	.12 ABC pull start engine
transmission	2 speed	2 speed	single speed

#2030 Nitro TC3 Team	\$459.99	side exhaust, pull start*
#2031 Nitro TC3 Team	\$459.99	rear exhaust, non pull start*
#2040 Nitro TC3 RTR	\$499.99	side exhaust, pull start**

*Does not include radio, batteries, engine, carb, fuel, fuel bottle, glow plug, and glow plug igniter. Non-pull start kit will also require starter box or electric hand starter with car starter donut, and battery for starter system.
 **Does not include fuel, fuel bottle, batteries, and glow plug igniter.