



TEAM ASSOCIATED

World Champion R/C Cars

FT 1/18 Scale Chassis Conversion Manual

This conversion kit works for the following Associated vehicles:

***#20101 RC18T2 RTR, #20103 RC18B2/RC18T2 Kit, #20106 RC18B2 RTR,
#20120 SC18 RTR, #20130 RC18LM RTR***

5/10

2

:: Introduction

Thank you for purchasing this Team Associated product. This manual contains instructions and tips for converting your Associated 1/18th scale belt drive vehicle to a Factory Team vehicle. Please take a moment to read through the manual and familiarize yourself with the steps. This conversion kit will work for the following vehicles: #20101 RC18T2 RTR, #20103 RC18B2/RC18T2 Kit, #20106 RC18B2 RTR, #20120 SC18 RTR, #20130 RC18LM RTR.

We are continually changing and improving our designs; therefore, actual parts may appear slightly different than the illustrations. New parts will be noted on supplementary sheets located in the appropriate parts bags. Check each bag for these sheets before you start to build.

Team Associated wants you to enjoy the process of building, driving, and maintaining your Associated vehicle. If you discover any problems or need help with the assembly of your model, please give us a call, or visit our web site, and we will do our very best to help you.



This Symbol Indicates a special note or instruction..

**Associated Electrics, Inc.
26021 Commercentre Dr.
Lake Forest, CA 92630**



**Customer Service
Tel: 949.544.7500
Fax: 949.544.7501**

<http://www.TeamAssociated.com> • <http://www.RC10.com> • http://twitter.com/Team_Associated • <http://bit.ly/AEonFacebook>

:: Teardown

STEP 1

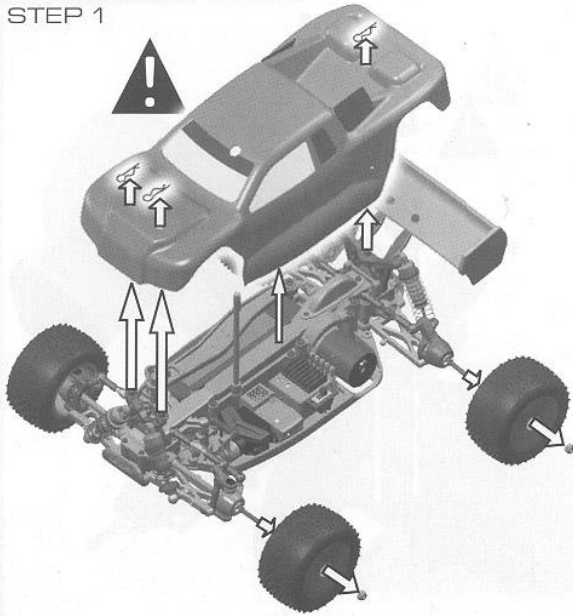

Remove all noted parts
and set aside for
re-installation later!

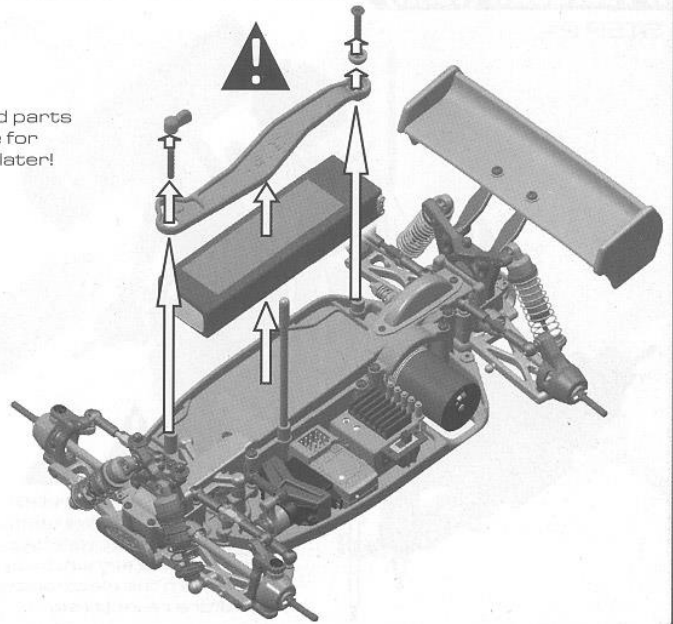

4

:: Teardown (cont.)

STEP 2

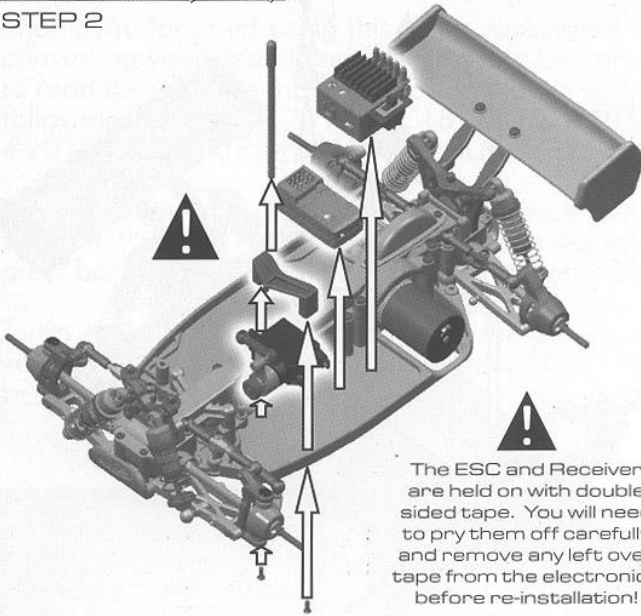

The ESC and Receiver
are held on with double
sided tape. You will need
to pry them off carefully
and remove any left over
tape from the electronics
before re-installation!

Remove all noted parts
and set aside for
re-installation later!

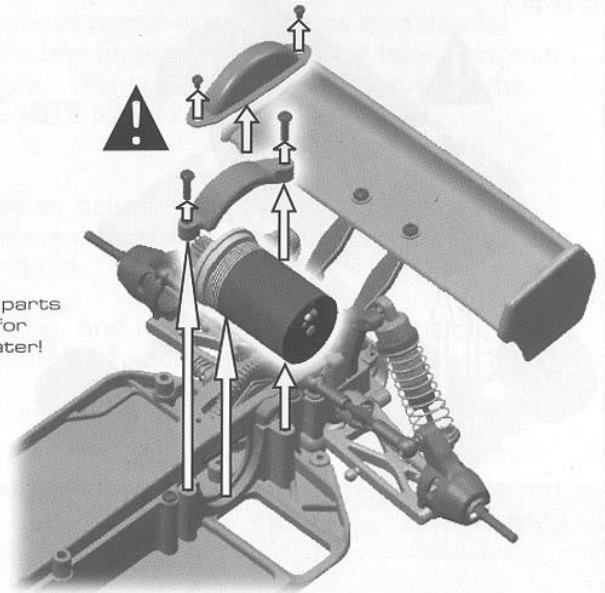

:: Teardown (cont.)

STEP 3

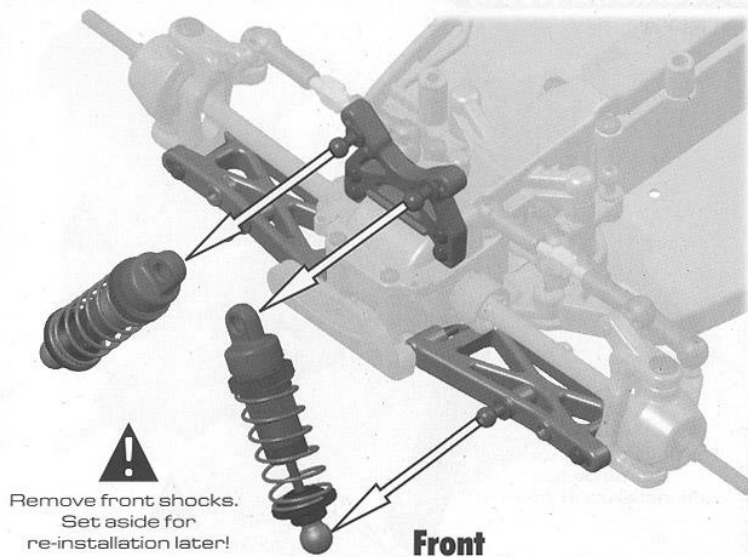
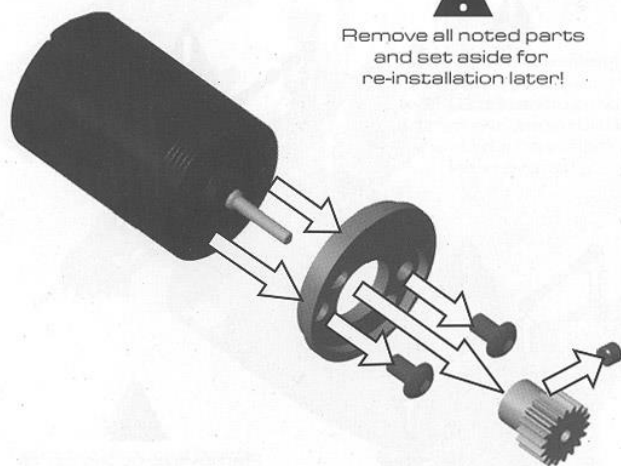

:: Teardown (cont.)

STEP 4

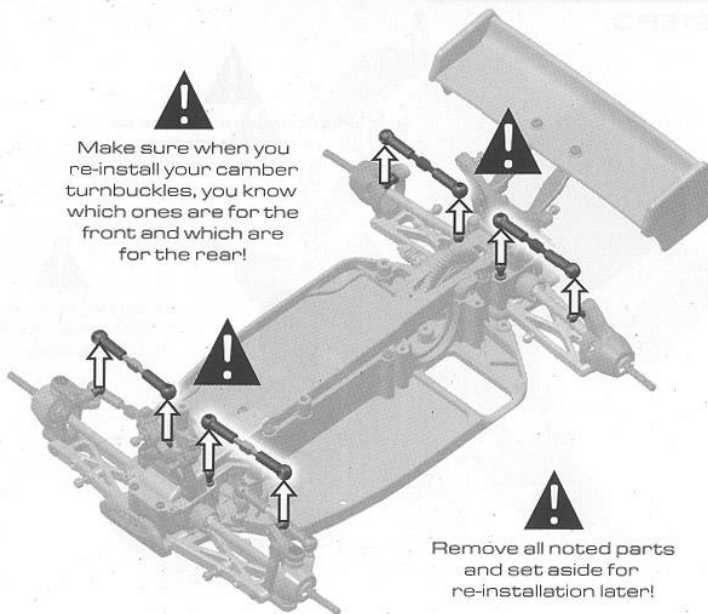
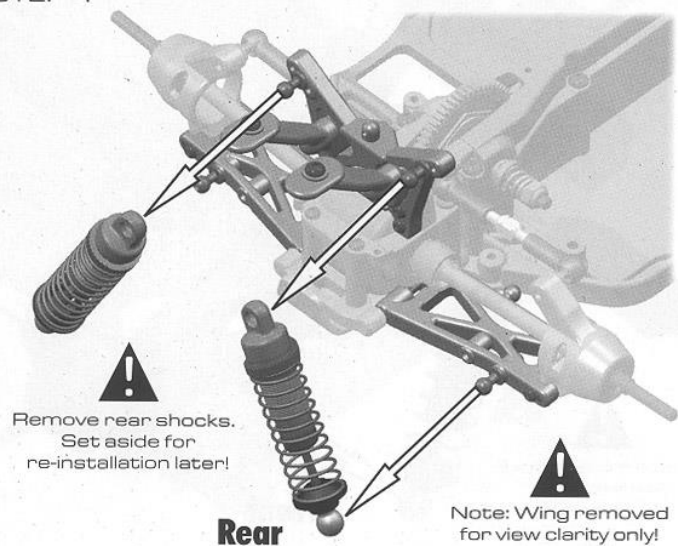

:: Teardown (cont.)

STEP 5

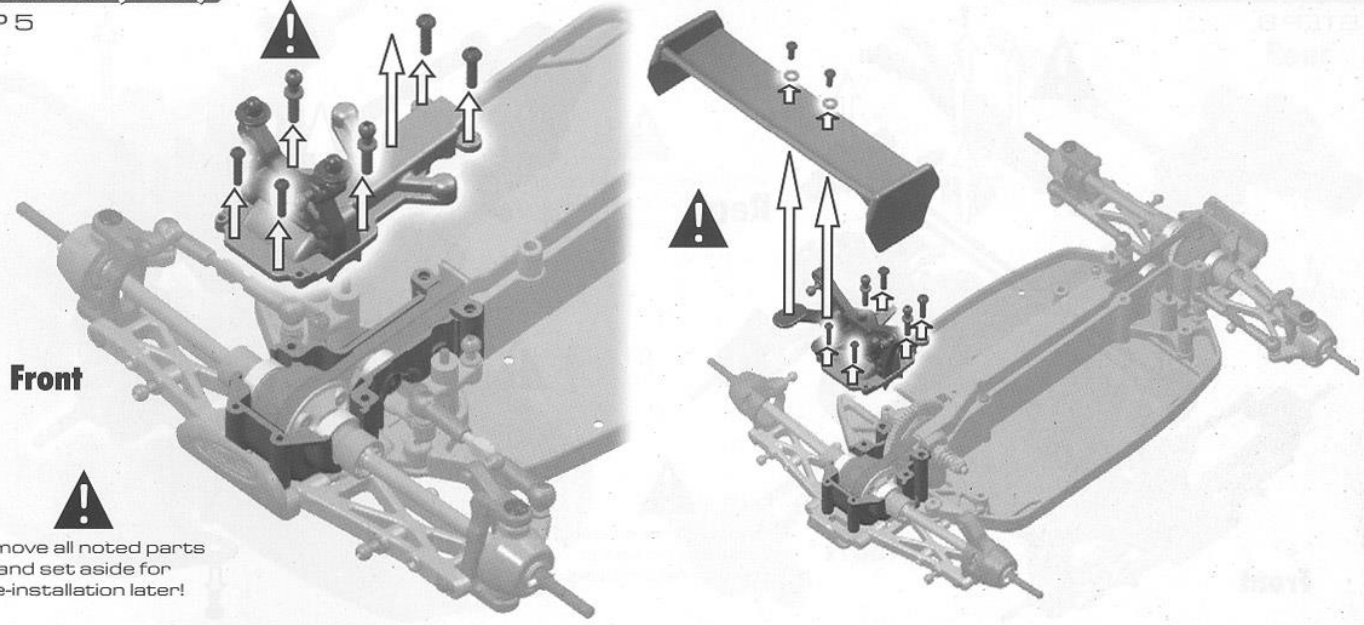

!
Remove all noted parts
and set aside for
re-installation later!

8

:: Teardown (cont.)

STEP 6

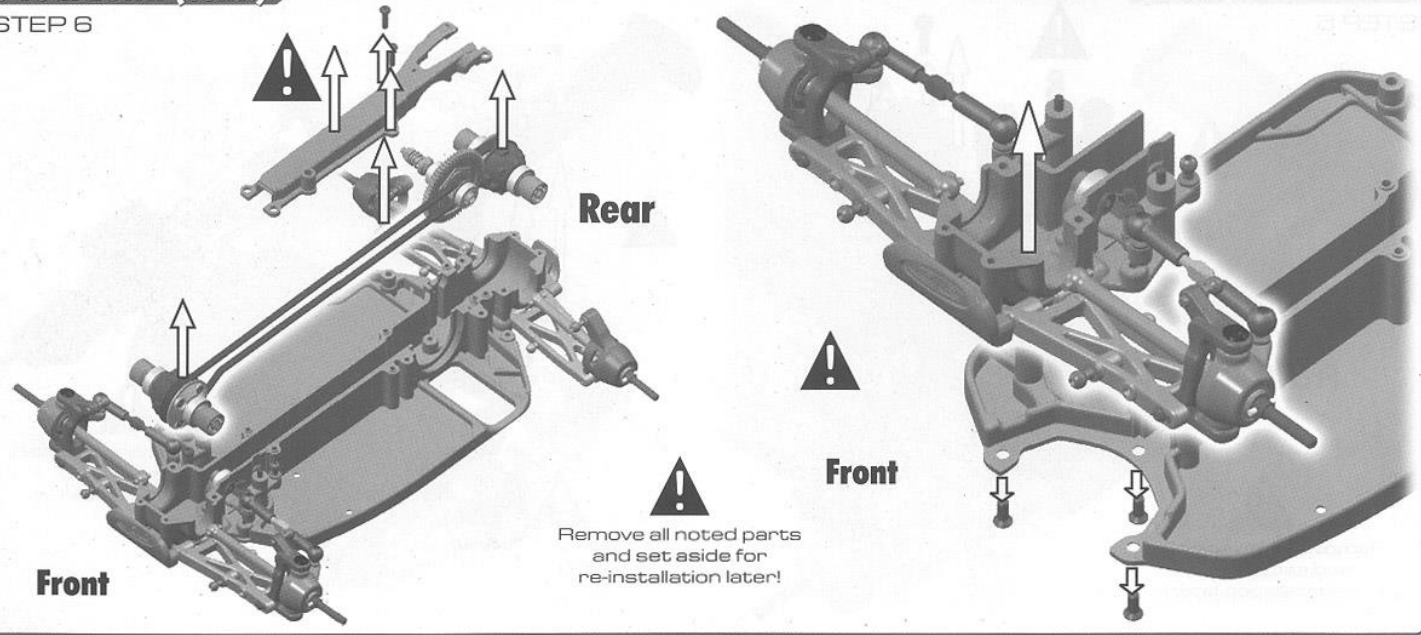

!
Remove all noted parts
and set aside for
re-installation later!

:: Teardown (cont.)

STEP 7

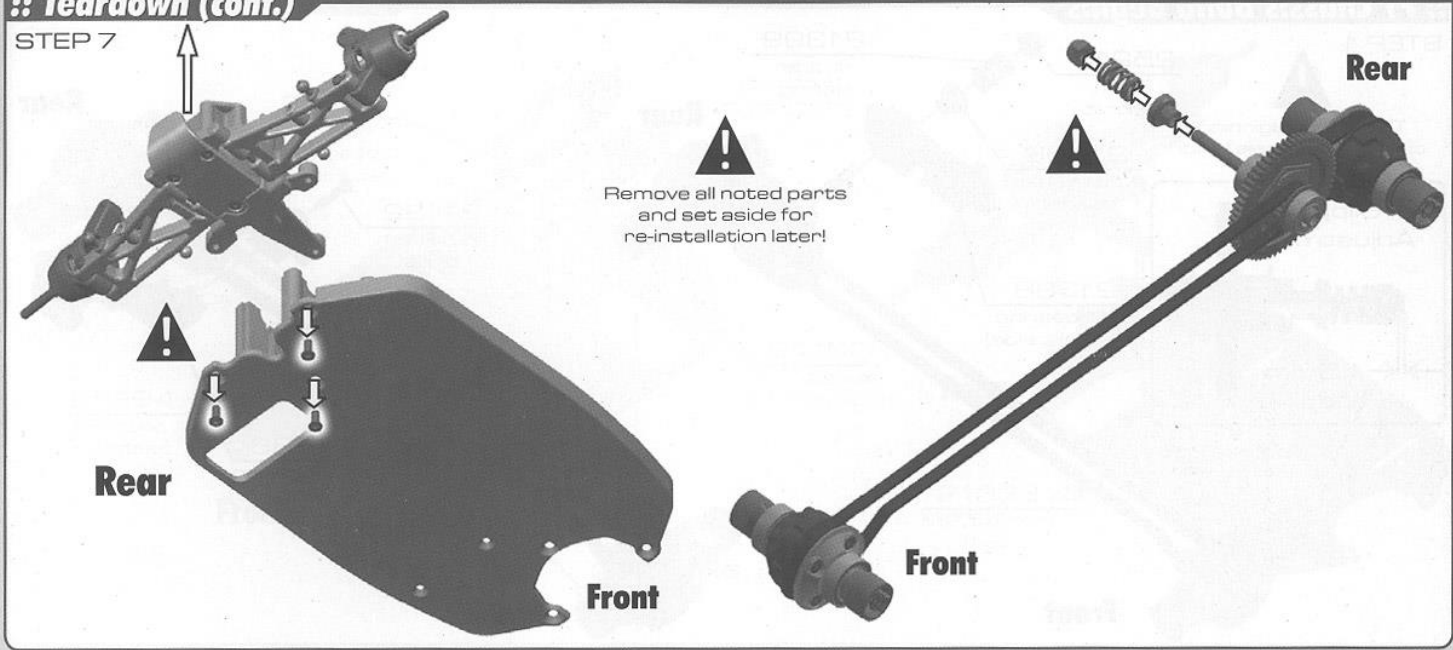

10

:: FT Chassis Build Begins

STEP 1



This is the beginning of your FT Chassis build!

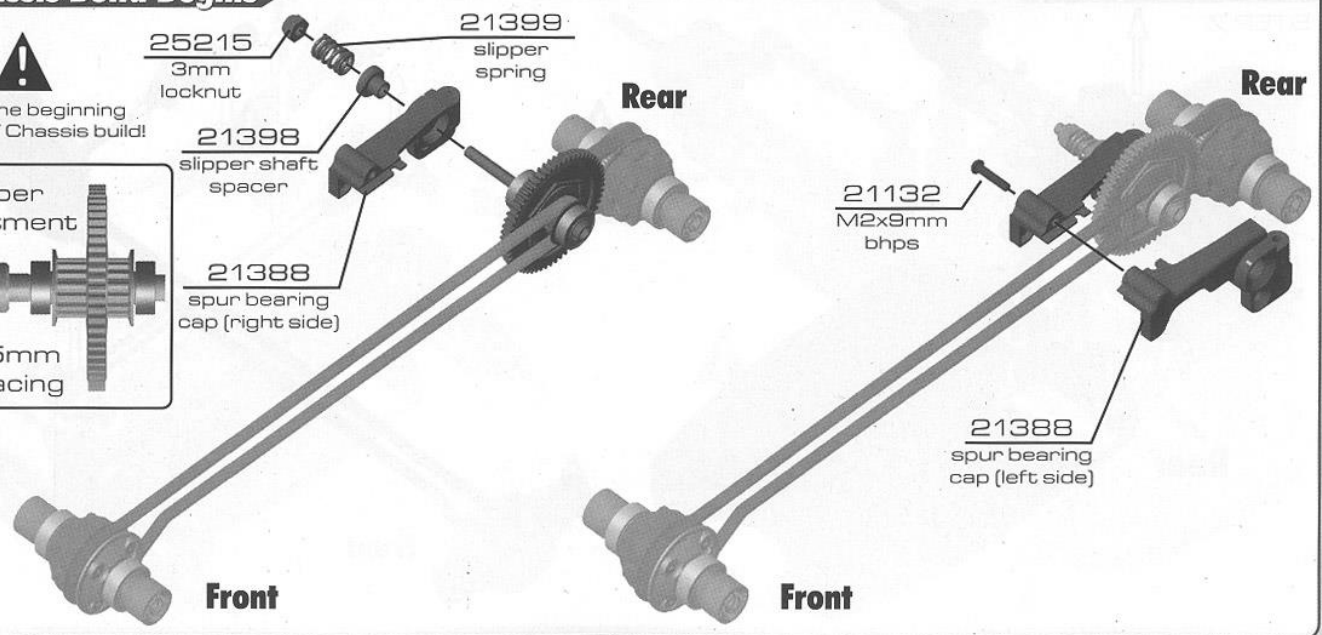
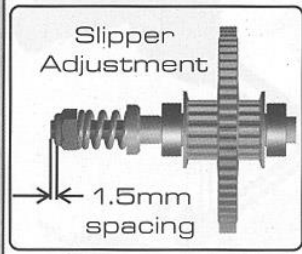

:: FT Chassis Build (cont.)

STEP 2



Racers Tip:
Chamfer the edges of the chassis and battery slots with mild sand paper to take off sharp edges. Seal edges with CA glue!

21394
FT front bulkhead

21393
FT rear bulkhead (right side)

21392
FT rear motor mount

Rear

21400
FT chassis (carbon fiber)

Rear

21333 x3
M2.5x6mm fhps

21333 x6
M2.5x6mm fhps

Front

:: FT Chassis Build (cont.)

STEP 3

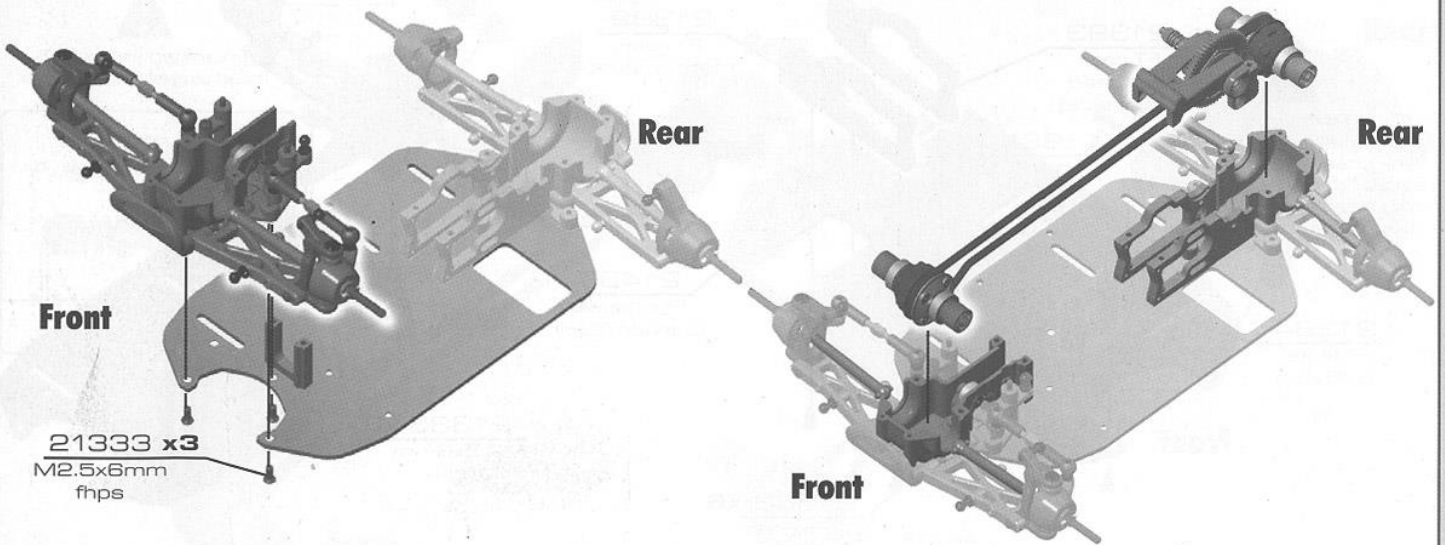

:: FT Chassis Build (cont.)

STEP 4

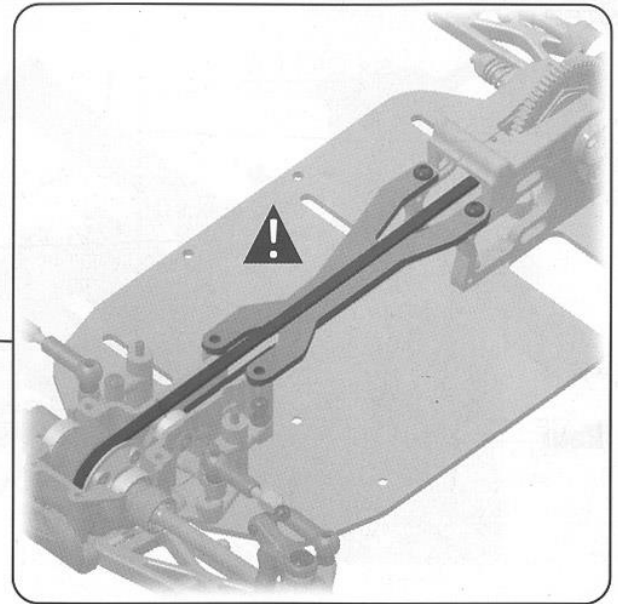
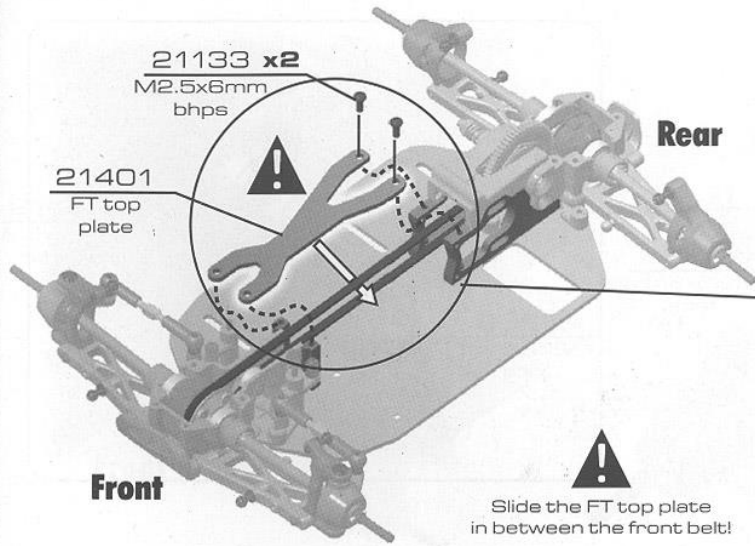

14

:: FT Chassis Build (cont.)

STEP 5

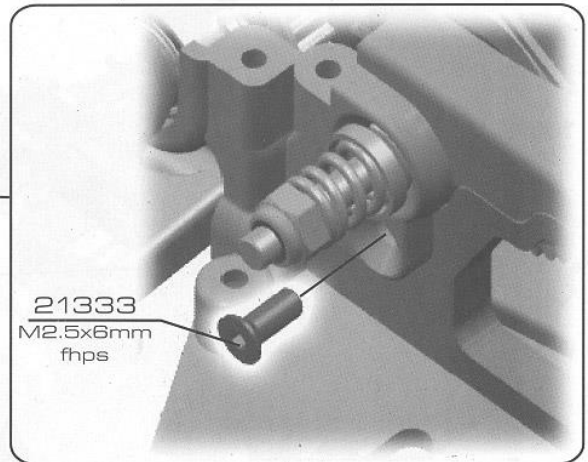
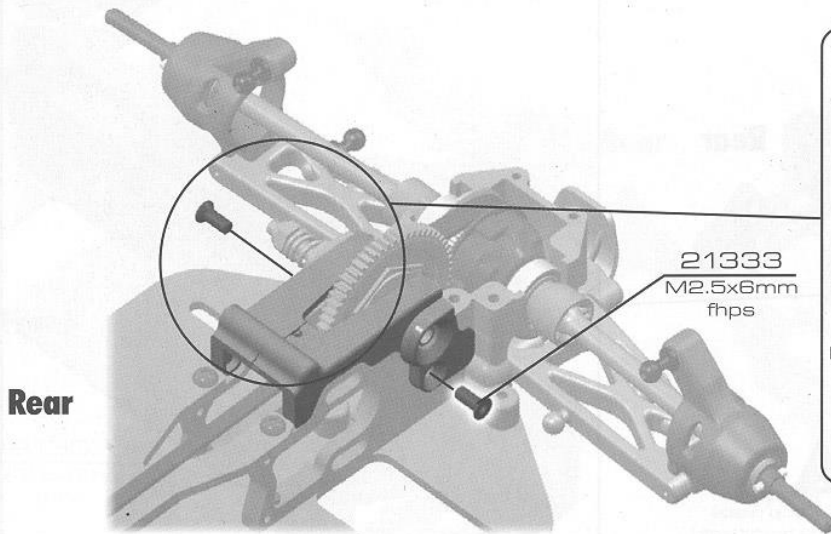

:: FT Chassis Build (cont.)

STEP 6

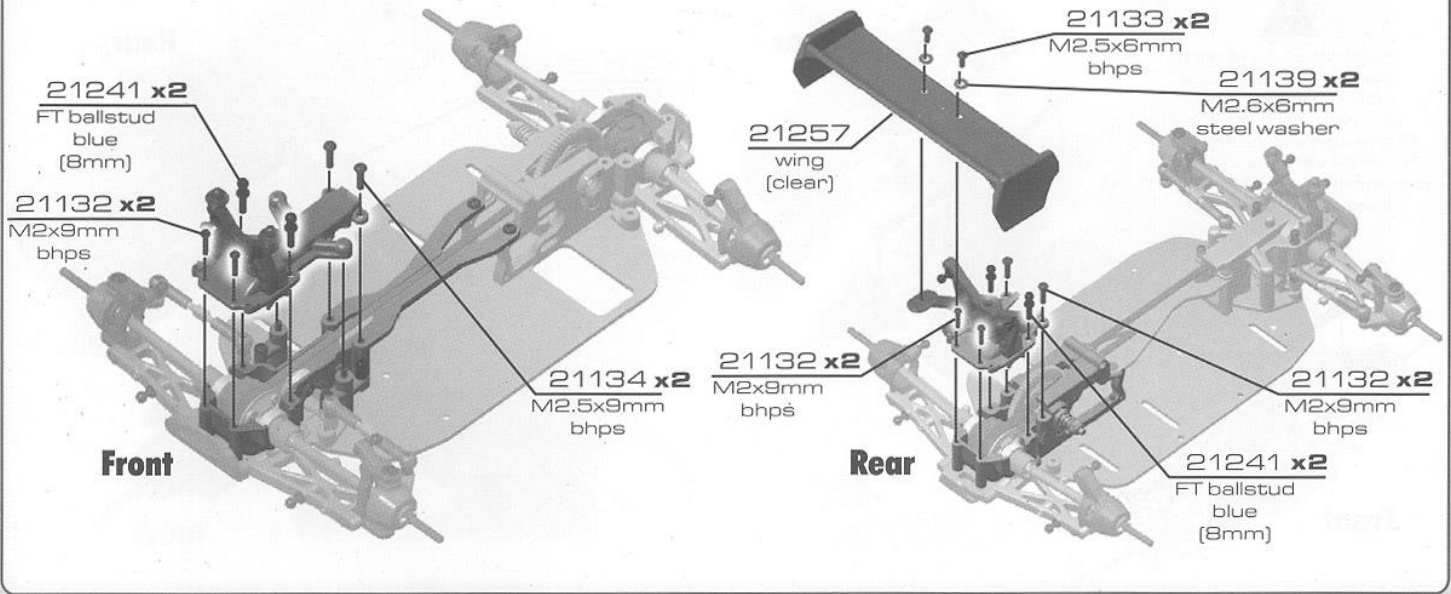

16

:: FT Chassis Build (cont.)

STEP 7



Refer to your owners manual to make sure you install the front and rear camber links in the correct positions! The RTR vehicles will have the same "molded" camber links, front and rear.

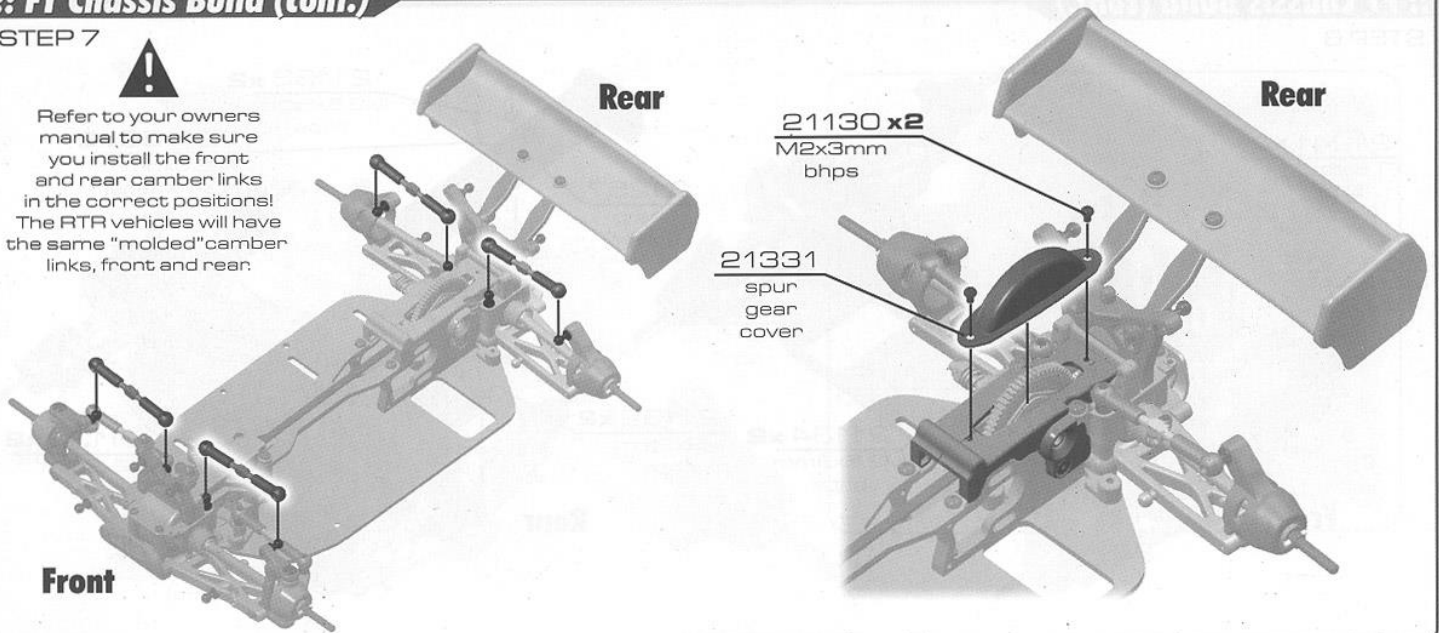

:: FT Chassis Build (cont.)

STEP 8

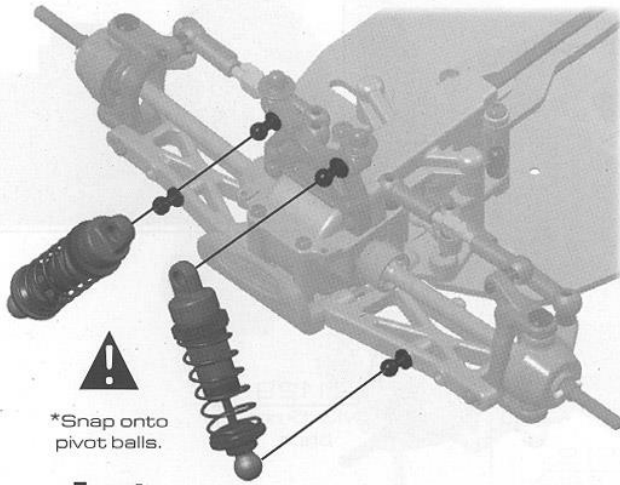

*Snap onto pivot balls.

Front

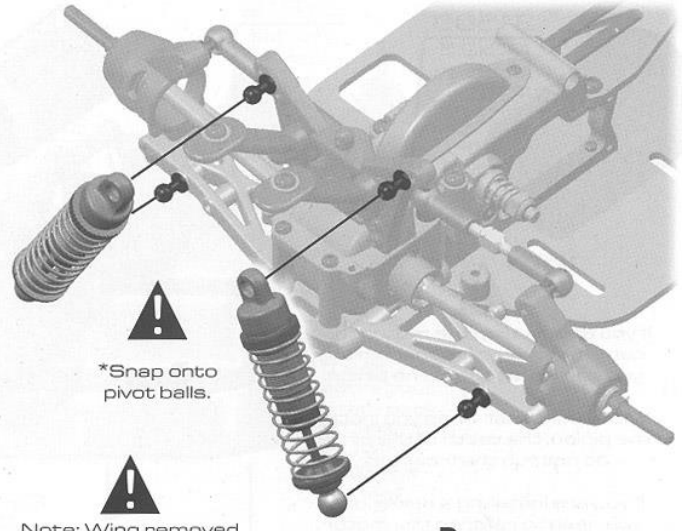

*Snap onto pivot balls.



Note: Wing removed for view clarity only!

Rear

18

:: FT Chassis Build (cont.)

STEP 9



31500
M3x2.5
set screw



If you are reusing the motor that came from your original vehicle, you can reuse the same pinion.

Make sure that when you install the pinion, the teeth of the pinion do not rub the front belt.

If you are installing a new motor, you need to refer to the motor manufacturers gearing instructions to find the correct pinion size needed.

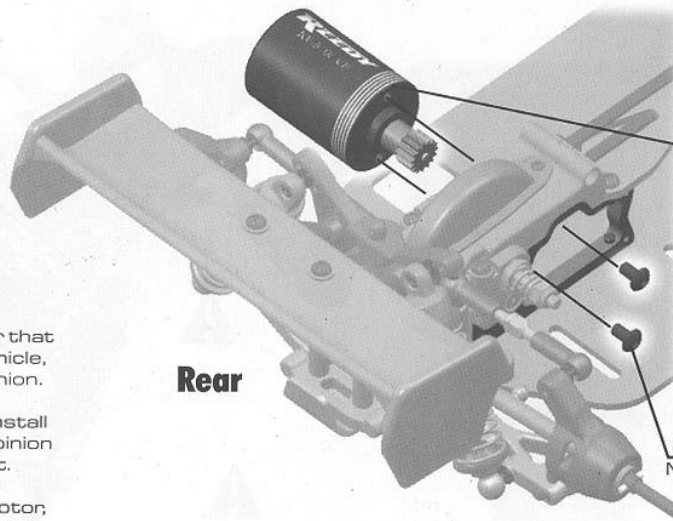

Rear

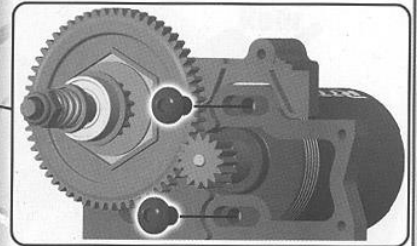

21129 x2
M3x5mm
bhps

:: FT Chassis Build (cont.)

STEP 10

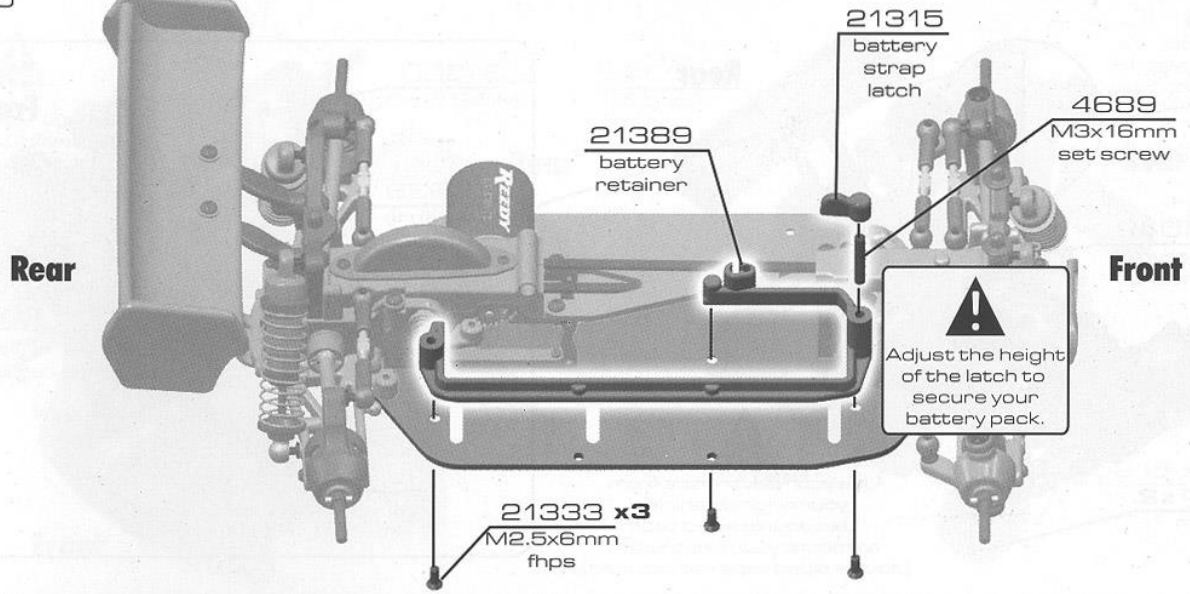

20

:: FT Chassis Build (cont.)

STEP 11

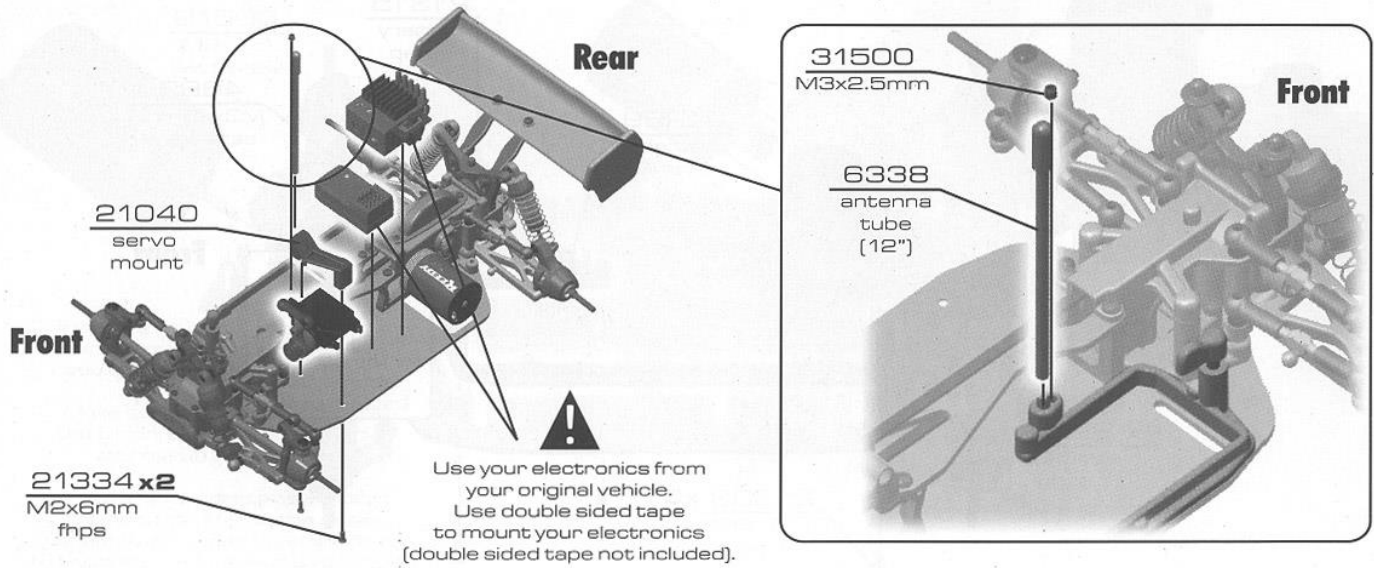

:: FT Chassis Build (cont.)

STEP 12

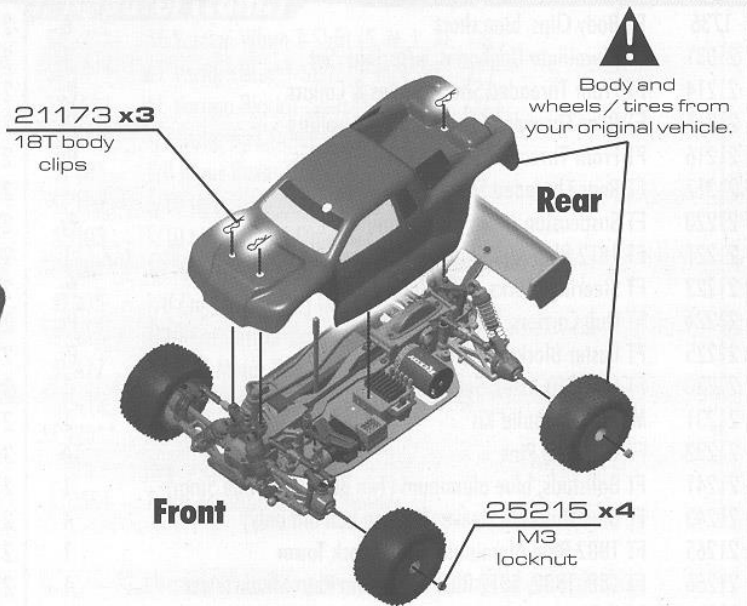
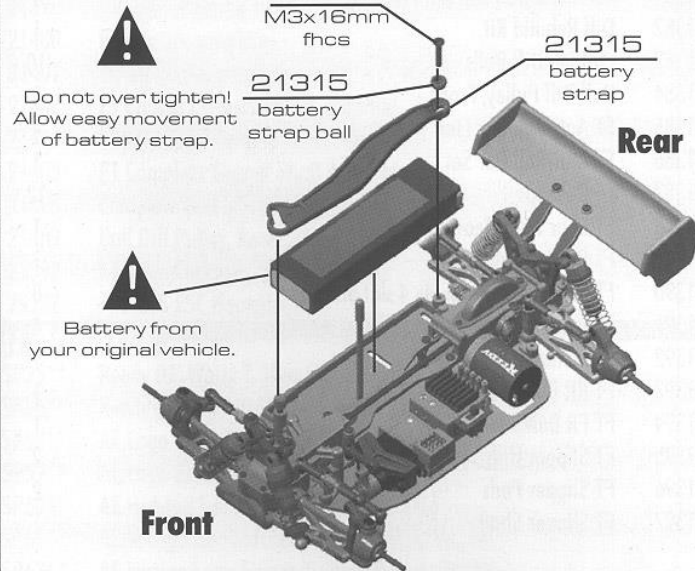

22

:: Factory Team Options

1736	FT Body Clips, blue short	6	21380	MIP CVD Assemblies (SC18, RC18LM, 18R)	1
21031	FT Aluminum Dogbones, w/springs Set	1	21381	Complete Ball Diff Kit, Front	1
21214	FT Front Threaded Shock Bodies & Collars	Pr.	21382	Diff Rebuild Kit	1
21215	FT Rear Threaded Shock Bodies, w/collars	Pr.	21383	Carbide Diff Balls	10
21216	FT Front Threaded Shock Kit, with Collars	Pr.	21384	Ball Diff Pulley, Front	1
21217	FT Rear Threaded Shock Kit, w/collars Set	1	21385	FT Anti-Roll Bar Link	4
21220	FT Suspension Arms, blue aluminum	Pr.	21386	FT Anti-Roll Bar Set	1
21221	FT 18T2 Blue Aluminum Front Shock Tower	1	21387	FT Ballcaps	12
21223	FT Steering Blocks, blue aluminum	Pr.	21388	FT Spur Gear Bearing Caps	1
21224	FT Hub Carriers, blue aluminum	Pr.	21389	FT Battery Retainer	1
21225	FT Caster Blocks, blue aluminum	Pr.	21390	FT Pistons (4x 3 slot, 4x 4 slot pistons)	8
21230	FT MIP CVD Axles, Set	1	21391	FT Anti-Roll Bar Pivot	4
21231	MIP CVD Rebuild Kit	1	21392	FT Motor Mount	1
21232	FT CVD Axle Pins	4	21393	FT RR Bulkhead	1
21241	FT Ballstuds, blue aluminum (Two 8mm and Nine 5mm)	1	21394	FT FR Bulkhead	1
21243	FT Blue Outdrive Sleeves (Use on ball diff only)	4	21395	FT Slipper Hub	2
21265	FT 18B2 Blue Aluminum Front Shock Tower	1	21396	FT Slipper Pads	2
21266	FT 18B, 18B2, 18T2 Blue Aluminum Rear Shock Tower	1	21397	FT Slipper Shaft	1
21330	18T2 Bearing Set	1			

:: Factory Team Options (cont.)

21398	FT Slipper Shaft Spacer	1
21399	FT Slipper Spring	1
21400	FT Chassis, graphite	1
21401	FT Top Plate, graphite	1
21402	FT Chassis Conversion Kit, graphite	1
21404	18B2, 18T2 Titanium Turnbuckle Set	1
21405	FT Complete Slipper Shaft Assembly	1
21408	Complete Ball Diff Kit, Rear	1
21409	Ball Diff Pulley, Rear	1
25392	FT 3mm Locknuts, blue	10
29137	18T XPS ESC Heatsink	1

:: Apparel

SP35**	Reedy 09' White T-Shirt (M, L, XL, XXL, XXXL)	1
SP36**	Reedy 09' Black T-Shirt (M, L, XL, XXL, XXXL)	1
SP58**	AE Logo Black T-Shirt (M, L, XL, XXL)	1
SP59**	AE Logo Blue T-Shirt (M, L, XL, XXL)	1
SP60**	AE Hooded Sweatshirt (S, M, L, XL, XXL)	1
SP61**	AE Vertigo Hooded Sweatshirt (S, M, L, XL, XXL)	1
SP62**	AE Vertigo Long Sleeve T-Shirt (S, M, L, XL, XXL)	1

:: Apparel (cont.)

SP63**	AE Vertigo White T-Shirt (S, M, L, XL, XXL)	1
SP64**	AE Vertigo Blue T-Shirt (S, M, L, XL, XXL)	1
SP65**	AE Vertigo Black T-Shirt (S, M, L, XL, XXL)	1
SP100	1/8 Inner and Outer Boxes Only, Set	1
SP101	1/8 Inner Boxes Only, Set	1
SP102	1/10 Inner and Outer Boxes Only, Set	1
SP103	1/10 Inner Boxes Only, Set	1
SP410**	AE Hats Black (S-M, L-XL, XXL-XXXL)	1
SP415	1/8 Car Carrier Bag Only	1
SP416	1/10 Car Carrier Bag Only	1
SP417	1/10 FT Motor Bag	1
SP418	1/10 FT Car Carrier Bag with Boxes, Set	1
SP420**	AE Pit Gloves (M, L, XL)	Pr.
715	Reedy 2009 Track Banner	1
110684	Team Associated Track Banner	1

** Use part number plus the desired size when ordering!