

# REEDY

# 121 VS

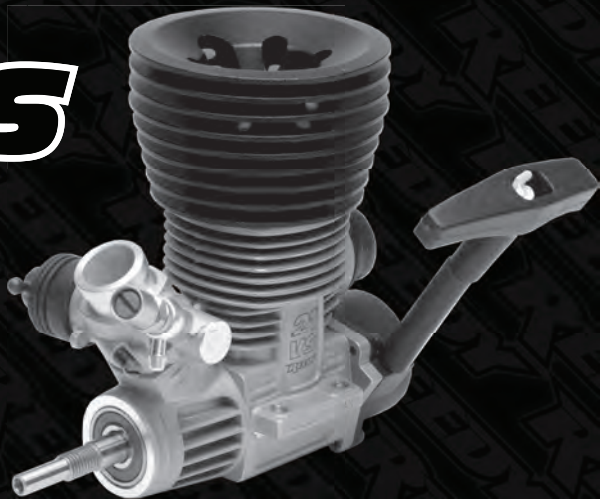

**:: Owner's Manual**

April 13' **#802**

## ***:: Introduction***

Thank you for purchasing Reedy's 121VS Nitro Engine. Designed in-house by our esteemed engineering staff, this engine is produced using state-of-the-art materials and high-tech manufacturing processes. The result is a powerful, user-friendly engine suitable for organized competition or casual driving sessions with your friends.

Please read the Owner's Manual thoroughly before starting your engine for the first time.

### ***Required Equipment***

The following items are required to set up and start your engine:

- Model Car Fuel w/20% lubricant
- Glow Igniter
- Fuel Bottle
- Air Filter Oil
- 8.0mm Glow Plug Wrench
- 3mm Flat Tuning Screwdriver
- MC59 Standard Glow Plug

**:: Features & Technical Data**

- ABC Construction
- Precision Ball Bearings
- Machined Aluminum Heatsink Head
- 2-Needle Carburetor
- Uses Standard Glow Plug
- Reliable Pull-Start system

Part #	802
Displacement	3.49cc
Maximum RPM	36,000
Stroke	16.8mm
Bore	16.26mm
Cylinder	ABC
Crankshaft Dia.	14.0mm
Glow Plug Type	Standard

## **:: Safety Instructions and Warnings**

This product is a powerful internal combustion engine. It is not a toy. As the owner, you are responsible for the safe and proper operation of the engine and the vehicle in which it is installed.

- Because deadly carbon monoxide gas will be released in the engine's exhaust, it should only be operated outdoors.
- During operation, the engine will become dangerously hot to the touch. Contact with the engine or parts connected to the engine could result in a serious burn.
- This engine must only be operated with fuels designed for R/C car engines.
- R/C fuels are highly flammable. Always keep fuel away from exposed flames or other sources of ignition. Carefully read the warnings on the R/C fuel container before use.
- Mount the engine securely and set throttle linkages as explained in the R/C vehicle's owner's manual. Always utilize a throttle return spring.

## **:: Safety Instructions and Warnings (cont.)**

- Never stop the engine by slowing the flywheel with fingers or other objects. Never attempt to plug the exhaust outlet with your fingers. With the engine running at neutral, pinch the fuel supply line to stop the flow of fuel to the carburetor.
- Keep spectators and small children at a safe distance when starting the engine and operating the vehicle.

## **:: Installation**

Please consult the R/C vehicle's owner's manual for proper installation of the engine, clutch assembly, exhaust, and linkages. Start with final drive ratio of 12.4:1. Depending upon the track layout and surface, the optimum ratio may fall between 11.6:1 and 13.2:1.

## ***:: Before Starting Your Engine***

Your new engine must be securely installed in your vehicle with the clutch assembly and exhaust system mounted, gear mesh set, fuel and pressure lines fitted, and a new oiled air filter securely attached to the carburetor. If your fuel tank does not have a built-in filter, add an external fuel filter on the fuel line between the tank and carburetor.

For optimal linkage smoothness and consistency, the carburetor should be rotated so that the barrel is pulled straight out of the carburetor body rather than at an angle (See Figure. 1). To rotate the carburetor loosen the carburetor retaining screw, then rotate the carburetor to the desired position and re-tighten the screw (See Figure. 2). Additionally, the throttle linkage ball should be positioned so that the throttle linkage is parallel to the chassis. (See Figure. 3)

Install an MC59 standard glow plug and tighten until snug. Then fill the fuel tank with fuel. You are now ready to start your engine.

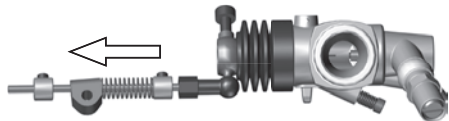
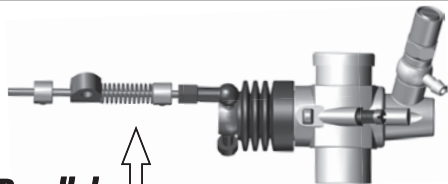
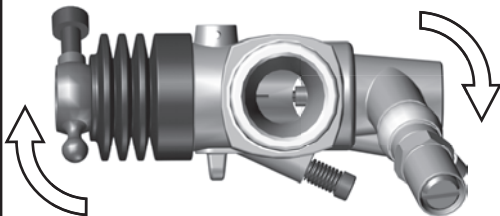
**:: Before Starting Your Engine (cont.)****(Figure 1)****Parallel  
to chassis****(Figure 3)****(Figure 2)**

## **:: Carburetor Adjustment**

Your engine comes with pre-set carburetor needle and idle settings. It is recommended to verify that the settings are correct. The high-speed and low speed needles should be adjusted to three turns out from fully closed. The idle setting (throttle slide gap) should be between .5mm and .7mm. These settings should be suitable to start the engine and begin the break-in process. However, different fuel types and atmospheric conditions may require adjustments to the settings.

There are three adjustments used to tune your engine:

1. The HIGH-SPEED NEEDLE adjusts the quantity of fuel when throttle is fully open (Medium/High RPM). Turn clockwise to reduce the quantity of fuel for a leaner mixture. Turn counter-clockwise to increase the quantity of fuel for a richer mixture.
2. The LOW-SPEED NEEDLE adjusts the quantity of fuel for best acceleration from stand still or low RPM). Turn clockwise to reduce the quantity of fuel for a leaner mixture. Turn counter-clockwise to increase the quantity of fuel for a richer mixture.
3. The IDLE ADJUSTMENT SCREW adjusts the engine idle speed at neutral throttle. Turn clockwise to increase idle RPM. Turn counter-clockwise to reduce idle RPM.  
(See diagrams of carburetor adjustments on page 9)



## :: Carburetor Adjustment Diagram

(Figure 4)

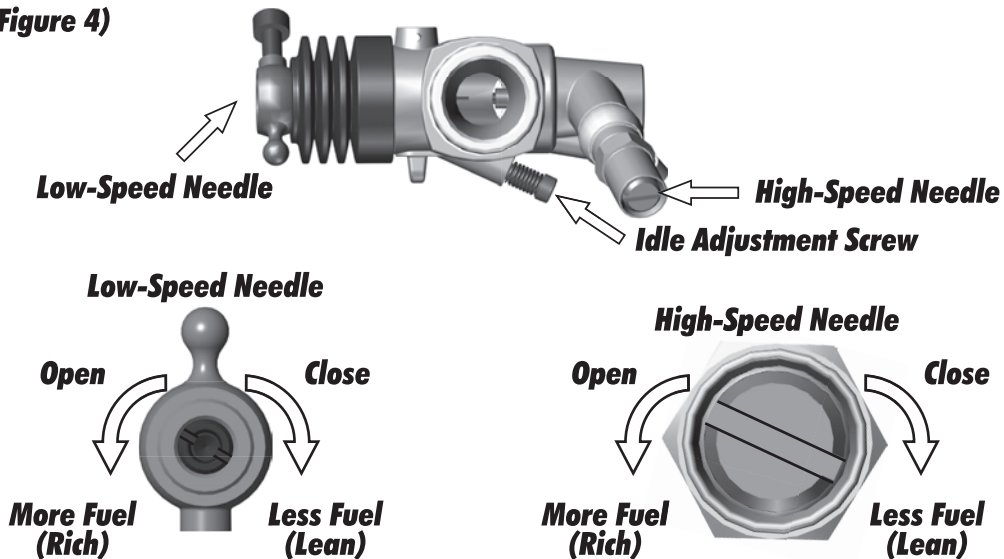

## :: Engine Break-In

Breaking-in the engine ensures that all the internal moving parts fit properly with their counterparts. By following the procedure outlined below, the engine will provide maximum power output, fuel mileage, and longevity. The same procedure should be followed after the installation of a new piston and cylinder.

1. Remove the plug and with a fully charged glow igniter, check that the plug lights. Then re-install the plug.
2. Place the vehicle on a stand with the wheels off the ground and with the throttle at neutral, pull the starter to turn the engine over until fuel can be seen flowing through the fuel line and entering the carburetor.
3. Connect the glow igniter and pull the starter a few times in successive tries to start the engine. A small amount of throttle may be required and is achieved by manual movement of the throttle servo. It may take a few tries before the engine fires. If the engine fails to start, lean the low speed needle by 1/12 turn (1 hour) and try again. (diagram)

**(Figure 5)**

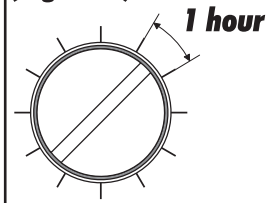

**:: Engine Break-In**

4. Once the engine has started, allow it to idle with wheels off the ground at this rich setting until one tank of fuel has been used being careful not to allow the engine to run out of fuel. During this time, the engine may die and require re-starting. A small amount of throttle input may also be required to keep the engine running. It is perfectly normal for the exhaust to emit a lot of smoke and oil during the break-in process. When finished, shut the engine off and allow it to cool completely.
5. Once the engine has cooled, turn on the radio and car, and then re-start the engine. Drive the car on the track or in a safe area until one tank of fuel has been used. During this process, the high speed needle can be leaned slightly (one-hour increments) as long as the temperature remains below 80°C (190°F). Be careful not to allow the engine to run out of fuel between tanks, and refrain from full throttle high RPM operation.
6. Allow the engine to cool to room temperature.

## **:: Final Adjustment**

Your engine is now ready to be tuned for maximum performance. Start the engine and drive the car until the engine warms up (1 - 2 minutes). It is very important that the engine reach operating temperature (200° -220° F) before carrying out any adjustments. Then follow these steps in order:

1. The high-speed needle setting is determined by driving your vehicle at maximum speed on the longest straight. After each full speed run, close the high-speed needle one hour at a time noting the difference in speed. The goal is to achieve the highest straight line speed while maintaining a visible trail of smoke from the exhaust. If the high-speed needle is closed too far, a reduction in speed and increase in temperature will result. If this occurs, open the high speed needle in one hour increments until the engine operates properly.
2. The low-speed needle setting is determined by how the vehicle accelerates from a stand still. Bring the vehicle to a complete stop and let it idle for 5-6 seconds, then give 100% throttle. If the vehicle emits excessive smoke and does not accelerate smoothly and quickly, the mixture is likely too rich. Turn the low-speed needle clockwise in one.....

## **:: Final Adjustment (cont.)**

- ...hour increments until the car accelerates quickly and smoothly. However, if the engine speeds up momentarily and then cuts out abruptly when 100% throttle is applied, the mixture is too lean. In this case, turn the low-speed needle counter-clockwise in one-hour increments until the car accelerates quickly and smoothly.
3. The idle adjustment screw should be set so that the engine runs just fast enough to maintain idle speeds without dying when the throttle is at the neutral position. Increase idle speeds by turning the idle adjustment screw clockwise and reduce idle speeds by turning the adjustment screw counter-clockwise.

When the adjustments are set correctly, light smoke will be visible from the exhaust and the engine RPM and acceleration will be strong and smooth.

Continually changing atmospheric conditions (temperature, humidity, barometric pressure) mean that your engine will always require small adjustments to optimize performance. Changes in altitude will also require tuning adjustments.

**:: Final Adjustment (cont.)**

Note: It is important to realize that a poorly performing clutch (bad bearings, weak or broken springs, interference with engine or chassis components, etc.) may trick you into making adjustments that are not necessary or incorrect resulting in an improperly tuned and poorly running engine. Be sure your clutch is in perfect running order at all times.

**:: Cleaning & Maintenance**

Proper cleaning and maintenance of your engine will result in maximum power output, fuel economy, tuning consistency, and longevity. Please read and familiarize yourself with the following:

**Air Filter** - A clean air filter with well-oiled foam element is critical for maximum performance and engine protection. Change and service air filters on a regular basis to reduce the possibility of premature engine wear and to maintain maximum performance.

**Fuel Filter** - Dirt particles can accumulate and restrict the flow of fuel.

## **:: *Cleaning & Maintenance (cont.)***

Inconsistent tuning and reduced performance will result. Install a fuel filter in line between the fuel tank and carburetor to trap these harmful particles. Be sure to clean the fuel filter regularly to remove any accumulation.

**Carburetor** - Remove and disassemble the carburetor on a regular basis. Clean each needle and adjustment screw, and inspect the o-rings for damage. If any damage exists, replace it. It is good practice to change the o-rings regularly even if they appear undamaged. After cleaning, re-assemble the carburetor making sure that the needles are set as they were before disassembly. It will be necessary to make slight adjustments to the needles when the engine is restarted.

**Fuel Tank** - To prevent residual build-up in the fuel tank and fuel lines, remove any excess fuel from the fuel tank after each run and run the engine to burn any remaining fuel in the fuel lines.

**Engine** - When through with the day's running, empty the fuel tank and run the engine to burn any remaining fuel. The engine will need to be....

**:: Cleaning & Maintenance (cont.)**

....started a few times to accomplish this. All fuel has been consumed when the engine will no longer start. Now remove the glow plug and inject a few drops of after run oil into the engine. Then re-install the glow plug and turn the engine over for 3-5 seconds using your starter box or pull-start. Remove dirt from the outside of your engine with a heavy brush. Oily and greasy deposits should be removed with Kerosene or Methanol.

Parts Replacement - Over time, even a perfectly tuned and maintained engine will experience a reduction in performance due to normal wear of its mechanical parts. Replacing worn parts will ensure efficient operation of the engine.

We recommend replacing the appropriate part if you experience the following symptoms:

- Engine sound changes and easily overheats - The front and/or back bearing are the likely cause and should be replaced.



## **:: Cleaning & Maintenance (cont.)**

- Reduction in power and acceleration or idle RPM is inconsistent - Compression has been reduced due to a worn piston and cylinder. Replace the piston, cylinder, connecting rod, and bearings (if necessary) at this time to regain performance.

## **:: Trouble Shooting**

### The Engine Fails to Start

- Fuel is not reaching the carburetor.  
*Be sure that the fuel tank is full and the fuel line is connected to the carburetor.*
- The fuel line is broken or perforated.  
*Check and replace fuel line if necessary.*
- The glow plug is burned out or glow igniter battery is dead.  
*Replace the glow plug or recharge the glow igniter battery.*
- The fuel filter, air filter, or exhaust pipe is clogged.  
*Clean/replace the fuel or air filter. Unclog the exhaust pipe exit.*
- The engine is flooded (too much fuel).  
*Remove the glow plug and run the engine on the starter box/pull-start...*

## **:: Trouble Shooting (cont.)**

....to allow excess fuel to escape.

- Incorrect carburetor needle settings.  
*Return the needle setting to factory settings or to the last known working settings.*
- The starter box motor is spinning the wrong direction or not turning fast enough.  
*Check starter box wiring and wire correctly. Charge starter box battery.*

### The Engine Starts Then Quickly Dies

- Low fuel.  
*Fill fuel tank.*
- Glow plug is damaged.  
*Replace glow plug.*
- The clutch assembly is damaged or misadjusted.  
*The clutch bell should spin freely when the engine is not running. Check the vehicle owner's manual for recommendations.*
- The fuel filter, air filter, or exhaust pipe is clogged.  
*Clean/replace the fuel or air filter. Unclog the exhaust pipe exit.*

## **:: Trouble Shooting (cont.)**

- Glow igniter is disconnected too quickly.  
*Leave the glow igniter connected until the engine is running smoothly.*

### The Engine Does Not Maintain a Steady Idle

- Glow plug type is not suitable for climate conditions.  
*See glow plug manufacturer's recommendations for correct plug type.*
- Incorrect fuel type.  
*Be sure to use fuel for model cars with the proper nitromethane and oil content.*
- The exhaust system is not fastened correctly.  
*Install the exhaust pipe and manifold per the manufacturer's instructions.*

### The Engine Fails to Attain Maximum RPM

- Incorrect or insufficient break-in period.  
*Adjust the high-speed needle or repeat the break-in procedure.*
- The exhaust system is not fastened correctly.  
*Install the exhaust pipe and manifold per the manufacturer's instructions.*

## **:: Trouble Shooting (cont.)**

- The fuel line is broken or perforated.  
*Check and replace fuel line if necessary.*

### The Engine Does Not Accelerate Responsively

- Glow plug is damaged.  
*Replace glow plug.*
- Needle settings are too rich.  
*Gradually close the high-speed and low-speed needles.*

## **:: Warranty**

Your engine is warranted to the original purchaser for 30 days from the date of purchase against defects in material and workmanship. Engines that have been mishandled, misused, abused, or damaged by the user are not covered under warranty. Associated Electrics Inc. is not liable for any loss or damage, whether direct or indirect, incidental or consequential, or from any special situation, arising from the use, misuse, or abuse of this product.

## :: Carburetor Exploded View

25318	NEEDLE VALVE for .21/4.60/121VS	1
25388	RETURN SPRING .28/121VS	1
25389	COMPLETE CARB .28/4.60/121VS	1
25394	O-RING SET .28/4.60	1
25452	SLIDE VALVE 8.0/121VS	1
25458	IDLE SCREW 4.60/121VS	1

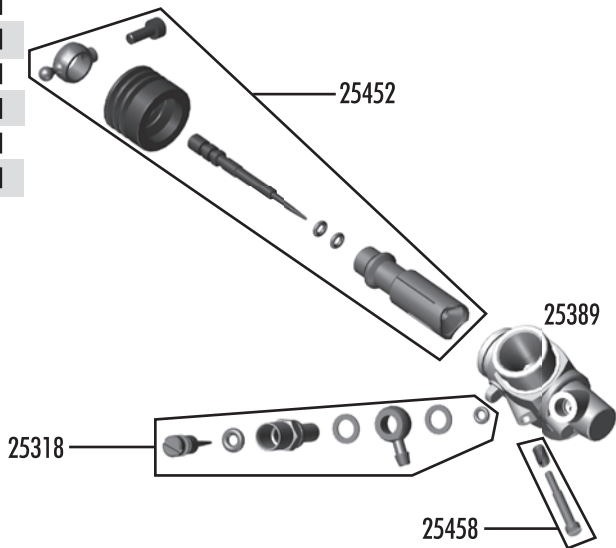

# :: Engine Exploded View

# 22

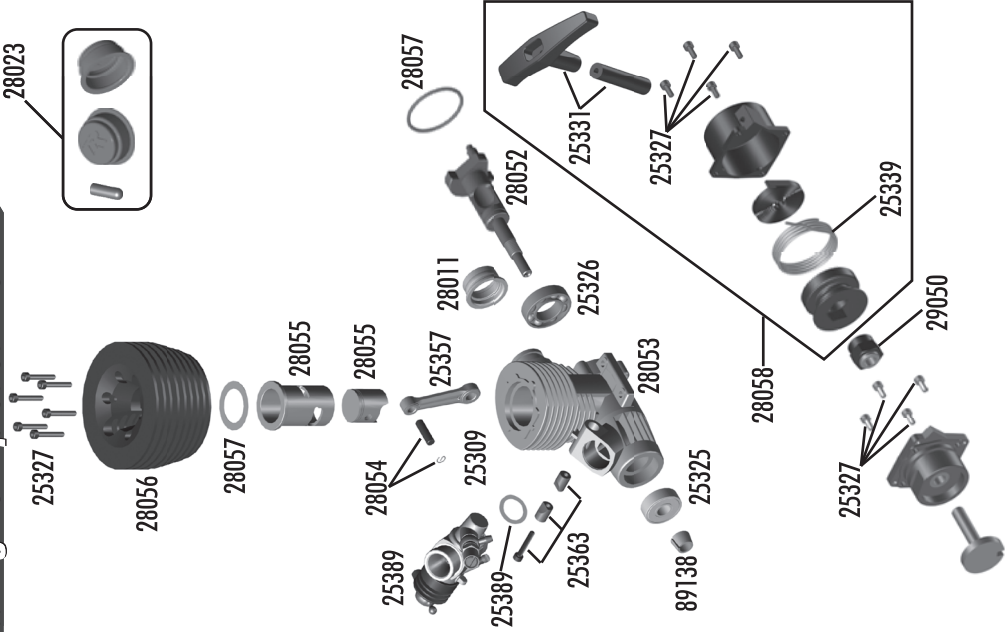

**:: Engine Parts List**

25309	CIRCLIP .21/4.60/121VS	1
25318	NEEDLE VALVE .21/4.60/121VS	1
25325	CRANKCASE BB F .21/121VS	1
25326	CRANKCASE BB R .21/121VS	1
25327	SCREW SET .21/121VS	1
25331	PS HANDLE .21/4.60	1
25339	PS CORD .21/4.60/121VS	1
25357	CON ROD 4.60/121VS	1
25363	CARB RET BOLT 4.60/121VS	1
25388	RETURN SPRING .28/121VS	1
25389	CARB .28/4.60/121VS	1
25394	O-RING S. .28/4.60	1
25452	SLIDE VALVE 8.0/121VS	1
25458	IDLE SCREW 4.60/121VS	1
28011	121 EXHAUST GASKET	1
28023	121 DUST CAP SET	1
28052	121VS CRANKSHAFT	1
28053	121VS CRANKCASE	1
28054	121VS WRIST PIN ASSEMBLY	1
28055	121VS PISTON & CYLINDER	1
28056	121VS CYLINDER HEAD	1
28057	121VS GASKET SET	1
28058	121VS STARTING COVER SET	1
29050	ONE-WAY PS .12/.15/121VS	1
89138	FLYWHEEL COLLET	1



## ***Lifetime Engine Replacement Policy***

If you are the owner of a Reedy engine, you are eligible to receive a replacement engine on a exchange, or trade in, basis. You may trade in your old, worn out, or broken engine plus 50% of the current MSRP of that engine for a brand new engine. Please visit [www.reedypower.com](http://www.reedypower.com) for details regarding this program.

***[www.ReedyPower.com](http://www.ReedyPower.com)***

***Associated Electrics, Inc.***

***26021 Commercentre Dr.***

***Lake Forest, CA 92630 USA***