

# REACHING US

## CUSTOMER SUPPORT

(714) 850-9342  
 FAX (714) 850-1744  
 web site: www.rc10.com  
 or www.teamassociated.com



## ASSOCIATED ELECTRICS, INC.

3585 Cadillac Ave.  
 Costa Mesa, CA 92626-1401  
 USA  
 ©2000 Associated Electrics, Inc.

# BEFORE BUILDING

These instructions assume that you already have a TC3 kit. The Conversion Kit contains direct-fit parts that will replace comparable parts on your TC3. The instructions will show you where the TC3 Rally parts go; use your TC3 manual to disassemble your kit properly and reassemble with the new parts. Retain this instruction manual for reference and to help

When the instructions tell you to remove an "original" part, it is referring to the part currently on your TC3 kit.

When the instructions tell you to use a "Rally" part, it is referring to a part that is included in the TC3 Rally Conversion Kit.

## Front Shocks

### SHOCK SPRING

REMOVE original spring.  
 Replace with #6494 green spring.

### SHOCK SHAFT

REMOVE original shaft.  
 Replace with #6461 .56 shock shaft.

### SHOCK OIL

Use 25 wt. oil.

### SHOCK PISTON

Use #2 piston.

### SHOCK LIMITERS

Add 1 stock limiter to shaft inside body.

### SHOCK PRELOADS

Use one 1/8" and 1/16" per shock.

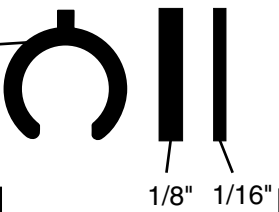
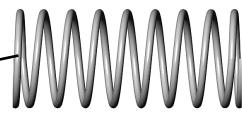

preload spacers

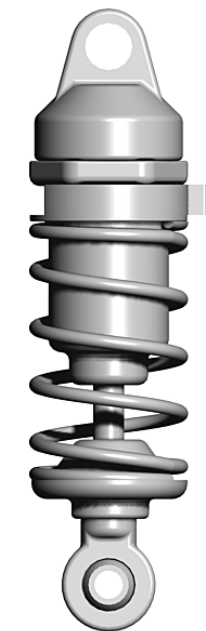

(stock TC3 shock)

## Rear Shocks

### SHOCK SPRING

REMOVE original spring.  
 Replace with #8232 black spring.

### SHOCK SHAFT

REMOVE original shaft.  
 Replace with #6461 .56 shock shaft.

### SHOCK OIL

Use 25 wt. oil.

### SHOCK PISTON

Use #1 piston.

### SHOCK LIMITERS

Add 1 stock limiter to shaft inside body.

### SHOCK PRELOADS

Use one 1/8", 1/16", and 1/32" per shock.

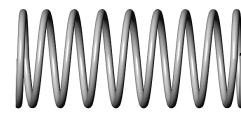

preload spacers

## Wheels & Tires



PRO-LINE 24mm WHEEL  
 #3956 24mm wheel



FOAM INSERT  
 #3957 foam insert



RALLY TIRE  
 #3957 tire

## Front Suspension Assembly

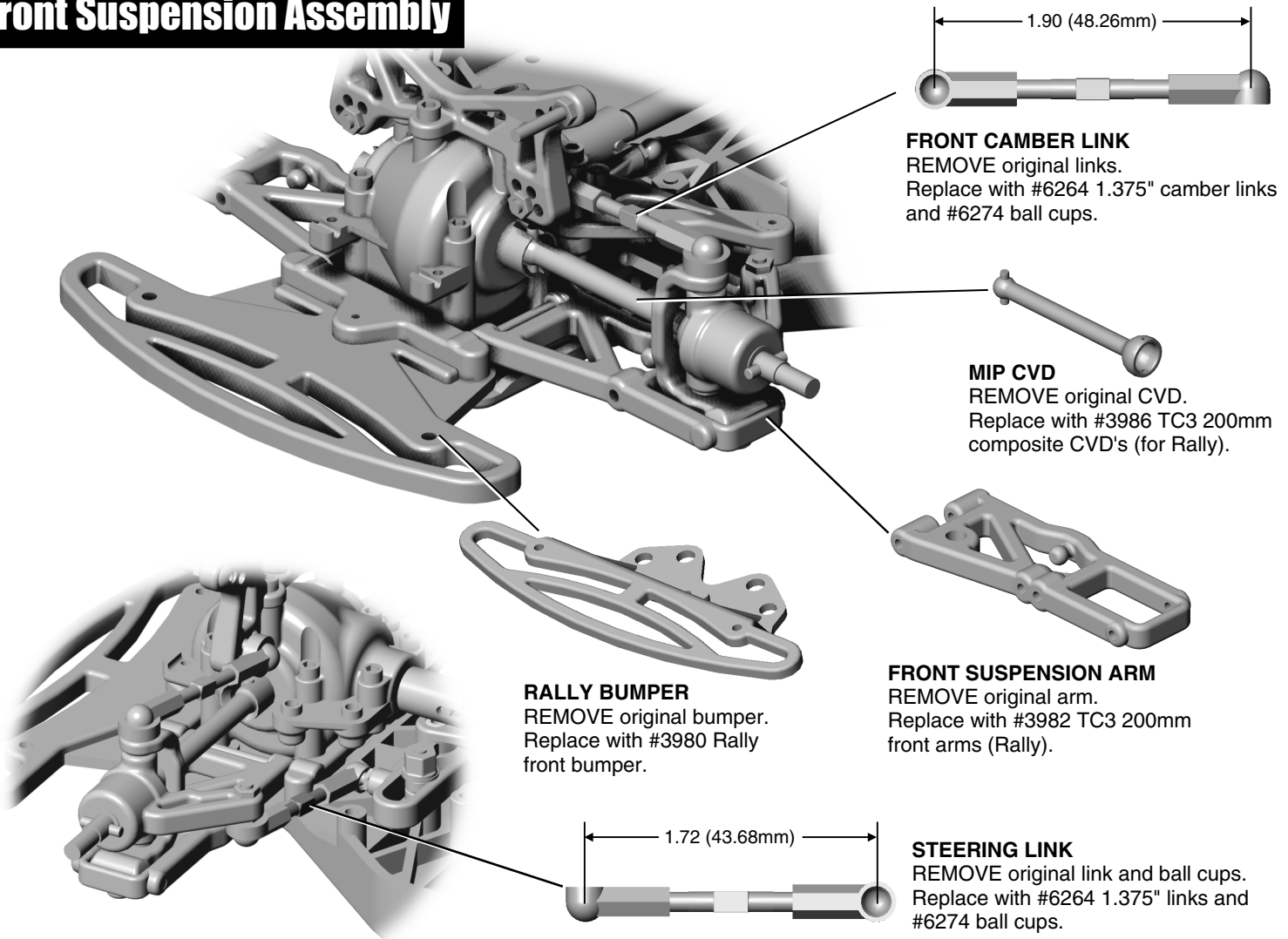

## Front Shock Mounting

Mount front shock to the stock position on shock tower and outer holes on new arm.

When complete, front suspension should look like the picture below right.  
 Compare photos of original TC3 and Rally TC3 Conversion.

**STOCK TC3**



**CONVERSION CHECKLIST:**

- > Increased ride height.
- > Outside shock hole mounting position on arm.
- > Stock camber link position.
- > Stock shock position on tower.

**RALLY TC3 CONVERSION**

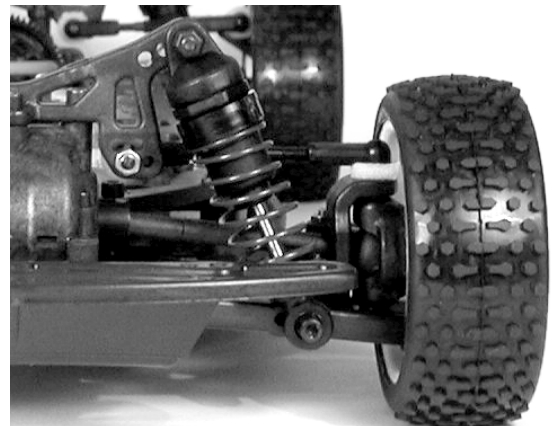

# Rear Suspension Assembly

Body posts mounted here

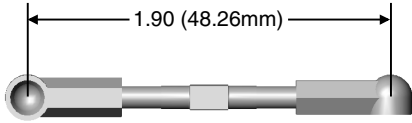

## REAR CAMBER LINK

REMOVE original links and ball cups.  
Replace with #6264 1.375" camber links and #6274 ball cups.

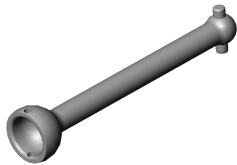

## MIP CVD

REMOVE original CVD.  
Replace with #3986TC3 200mm composite CVD (for Rally).

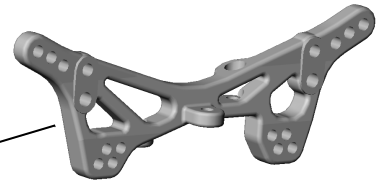
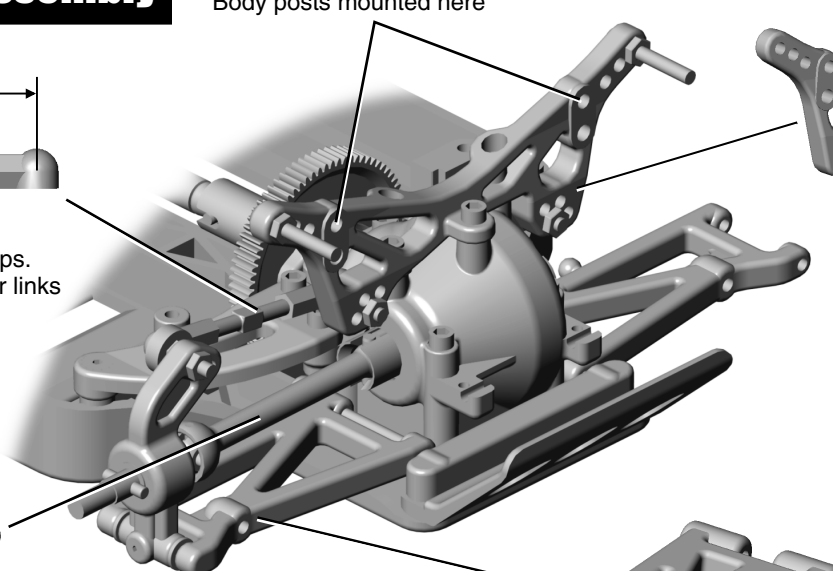

## REAR SHOCK TOWER

REMOVE original tower.  
Replace with updated #3895 TC3 rear tower.

*Mount original body posts to the back side of the rear tower.*

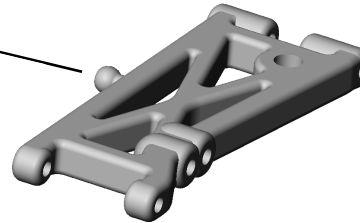

## REAR SUSPENSION ARM

REMOVE original arm.  
Replace with #3984 TC3 200mm rear arms (for Rally).

# Rear Shock Mounting

Mount Rear shocks to the stock position on the rear shock tower and inner holes on the new arms.

When complete, rear end should look like the picture below right.  
Compare photos of original TC3 and Rally TC3 Conversion.

## STOCK TC3



## CONVERSION CHECKLIST:

- > Increased ride height.
- > Outside shock hole mounting position on arm.
- > Stock camber link position.
- > Stock shock position on tower.
- > Rear body posts mounted on back of tower.

## RALLY TC3 CONVERSION

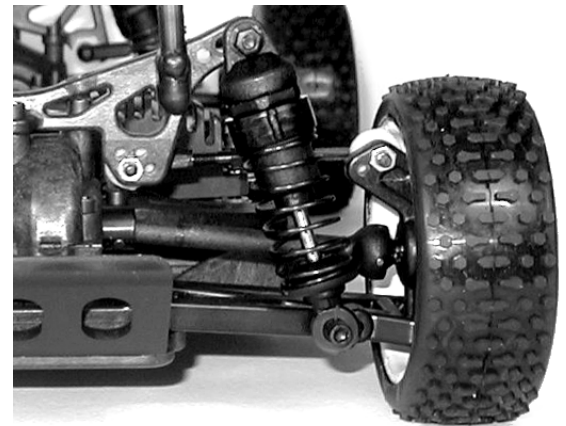

## CONVERSION PARTS LIST

3956	Pro-Line 24mm Wabash wheel	pr.	5.95	3986	200mm composite CVD	pr.	10.00
3957	Pro-Line rally tire with foam insert	pr.	12.50	5428	25 Weight Silicone Shock Oil	2oz.	3.50
3895	TC3 rear tower	1	7.00	6264	Turnbuckle, 1.375"	pr.	3.00
3980	TC3 Rally front bumper	1	4.00	6274	Ball cup	16	5.00
3982	TC3 200mm front arm	pr.	6.00	6461	Shock Shaft, .56	1	3.00
3984	TC3 200mm rear arm	pr.	6.00	6494	Green spring, 3.5 lb.	pr.	2.50
				8232	Black spring, 3.2 lb.	pr.	2.50