



240-1

Associated Transmission

240-1

#9350 Instruction Manual
For the **B2/B3/T3**



REMOVE THESE PARTS FOR: Steps 1-5

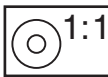

6573, qty 2
diff thrust washer



6574, qty 6
diff thrust ball

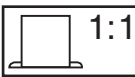

6575, qty 1
T-nut

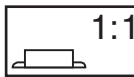

6575, qty 1
diff thrust bolt cover, nylon



6575, qty 1
2-56 diff bolt



6581, qty 12
diff balls carbide



6582, qty 1
diff spring



6589, qty 2
5/32 x 5/16
ball bearing



6588, qty 1
black grease



6591, qty 1
diff lube



9365, qty 1
diff gear



9367, qty 2
diff drive ring



9370, qty 1
left diff outdrive hub



9375, qty 1
right diff outdrive hub

TOOLS USED



step 1

SET UP DIFF GEAR

- 1 Add a generous amount of #6591 diff lube to the #9365 diff gear ball holes and push in the twelve #6581 diff balls. Then push the lube that came out back in.
- 2 Insert one #6589 bearing into the gear.

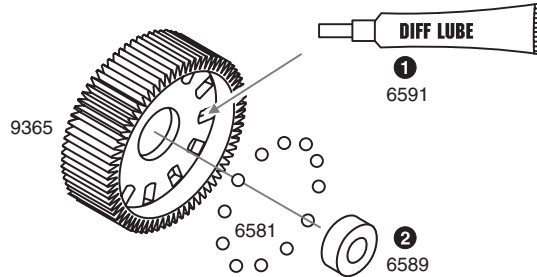

step 2

LEFT OUTDRIVE HUB

Push in the #6582 spring and #6575 T-nut.

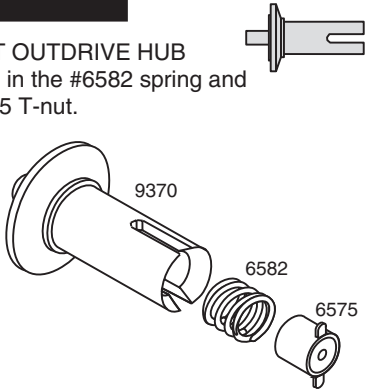

step 3

RIGHT OUTDRIVE HUB

- 1 Slide one #6573 washer onto the #6575 bolt. Apply a generous amount of #6588 black grease to the washer on the side facing away from the bolt head.
- 2 Stick six #6574 balls into the grease against the #6575 bolt and washer. Add the other #6573 washer. The grease will hold the balls in place during assembly.
- 3 Slide all this into the #9375 right outdrive hub, being careful not to lose any of the balls.
- 4 Insert the #6575 bolt cover.

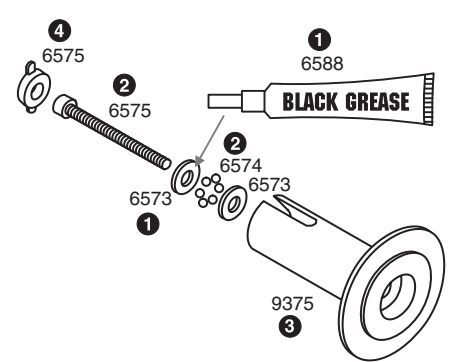

step 4

RIGHT OUTDRIVE HUB

- 1 Insert one #6589 bearing into the #9375 right hub.
- 2 Add a light coat of #6591 diff lube to right hub where shown.
- 3 Place a #9367 diff drive ring and then the gear assembly on the hub.

ASSEMBLE THE HUBS

- 4 Add light coat of #6591 diff lube to left hub where shown.
- 5 Place a #9367 diff drive ring on the hub.
- 6 Push the #9370 hub over the diff bolt and center the hub.

CHECK ALIGNMENT OF HUBS

- 7 Tighten the diff with your 5/64" Allen wrench, but not completely.
- 8 Rotate the diff hubs several times as you are tightening the bolt to check for proper alignment of the parts.
- 9 We'll adjust the diff on the next page.

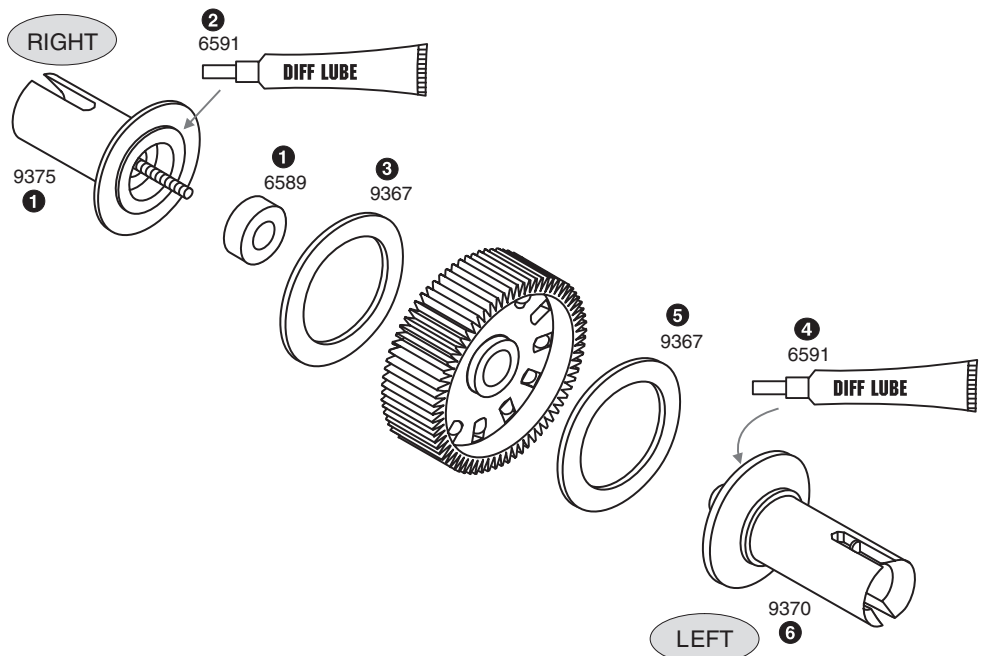

step 5

ADJUST THE DIFFERENTIAL

1 As you tighten the diff bolt, you will notice the T-nut ears moving closer to the bottom of the diff hub slot. This compresses the spring behind the T-nut. The spring should be fully compressed at the same time the T-nut reaches the end of the slot.

Caution: Pay close attention to feeling when

the spring is fully compressed. Do not overtighten the bolt. When you feel the spring fully compressed, loosen the diff bolt 1/8 of a turn. No more, no less. Your diff should now operate very smoothly when turning the hubs in opposite directions. After you have driven the car once, recheck the diff adjustment. Never adjust the diff any other way.

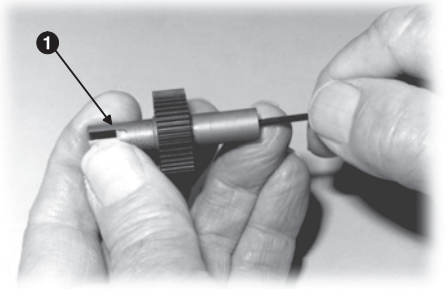

REMOVE THESE PARTS FOR:
Steps 6-7

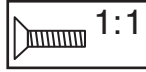

6292, qty 1
4-40 x 3/8

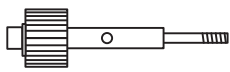

6571, qty 1
drive shaft/gear

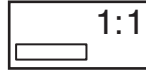

6572, qty 1
drive shaft
roll pin



6928, qty 3
4-40 x 1



7669, qty 2
drive shaft
spacer



9352, qty 1
right tranny case

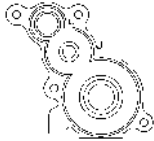

9352, qty 1
left tranny case



6903, qty 2
3/8 x 5/8
unflanged bearing

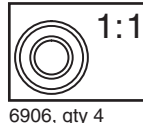

6906, qty 4
3/16 x 3/8
unflanged bearing



9360, qty 1
idler gear



9361, qty 1
idler gear shaft



7337, qty 3
washer, gold

TOOLS USED

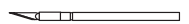
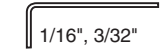
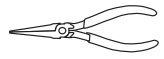

step 6

ADD BEARINGS TO THE CASE HALVES

- 1 Cut the two #9352 transmission case halves and the three #9352 spacers from the runner.
- 2 Add #6906 bearings to the top and #6903 bearings to the bottom of each case half.

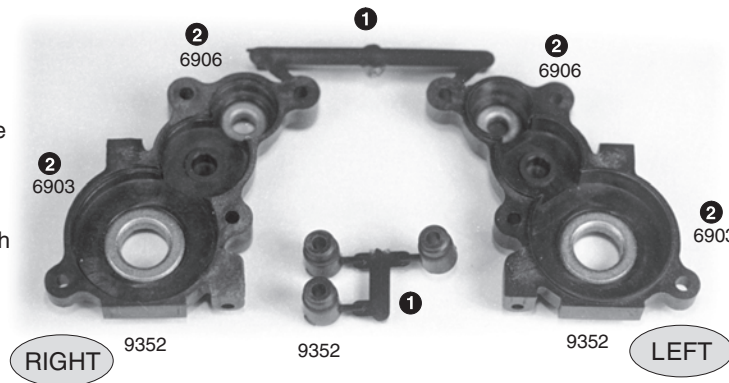

step 7

INSIDE THE TRANNNY

- 1 Install the right side diff assembly into the right case. (Page 2, Step 3 will show you which diff hub is the right side.)
- 2 Add the #7669 spacer to the #6571 drive shaft and put both into the case.
- 3 Install the two #6906 bearings in the #9360 gear, followed by the #9361 shaft. Insert the assembly into the case.
- 4 Add the other #7669 spacer to the #6571 shaft and put the case halves together.

OUTSIDE THE TRANNNY

- 5 Screw the halves together with one #6292 bolt.
- 6 Insert the #6572 roll pin into the shaft hole with your needlenose pliers.
- 7 Push the three #6928 bolts through, each with its own #7337 washer.

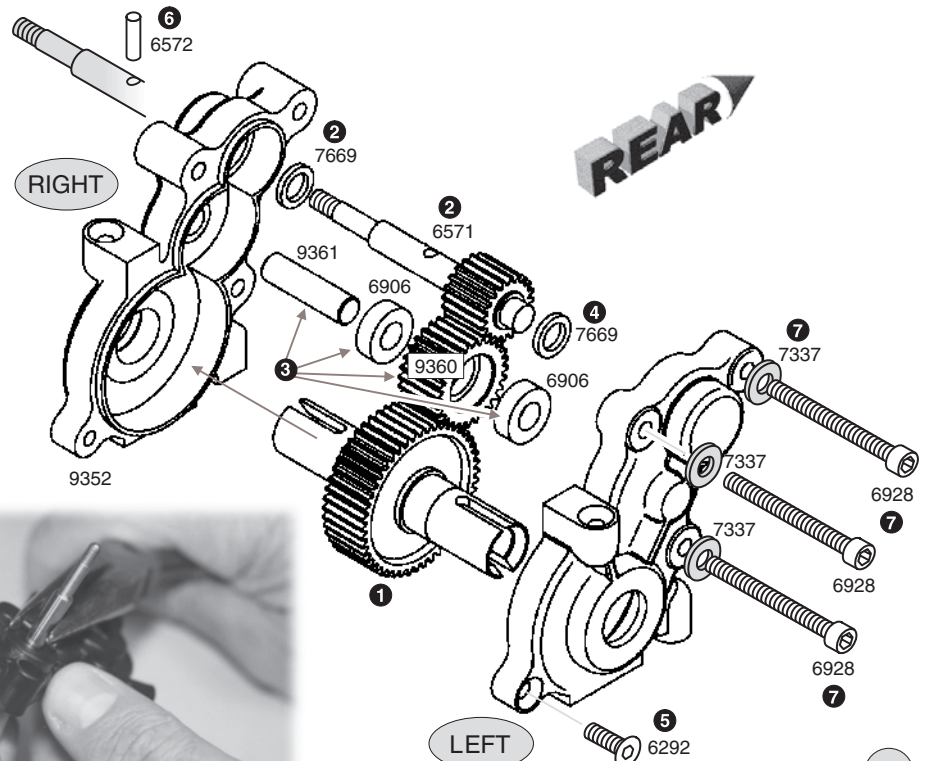
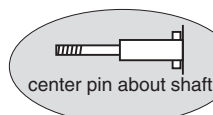

REMOVE THESE PARTS FOR: Steps 8-11

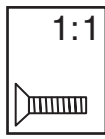

6292, qty 2
4-40 x 3/8



6568, qty 4
4-40 x 3/16

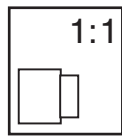

9352, qty 3
motor plate spacer



9251, qty 1
inner torque clutch hub

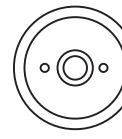

9252, qty 1
outer torque clutch hub



9253, qty 1
clutch disc



6587, qty 1
torque control spring



6594, qty 2
thrust bearing washer (thin)



6594, qty 2
thrust bearing washer (thick gold)

TOOLS USED

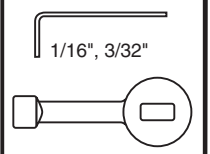

6594, qty 1
thrust bearing (thick gold)



6599, qty 1
3/16 x 3/8 bushing

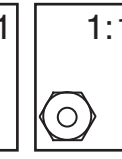

6629, qty 1
5-40 locknut

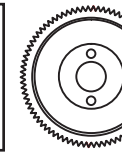

6693, qty 1
81T 48 pitch spur gear

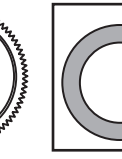

7373, qty 1
motor plate gasket foam

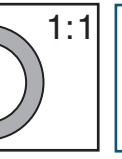

7874, qty 2
4-40 x 7/16



9245, qty 1
motor plate

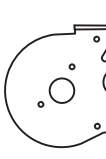

9380, qty 1
rear transmission brace

step 8

REMOVE THE BACKING

- 1 Remove the backing and center from the #7373 gasket.

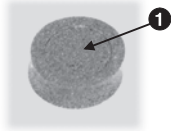

step 9

INSTALL THE MOTOR PLATE

- 1 Center the #7373 gasket around the large round hole of the plate.
- 2 Install the three #9352 spacers.
- 3 Line up the #9245 plate and fasten with the three #6928 screws of Page 3, Step 7.

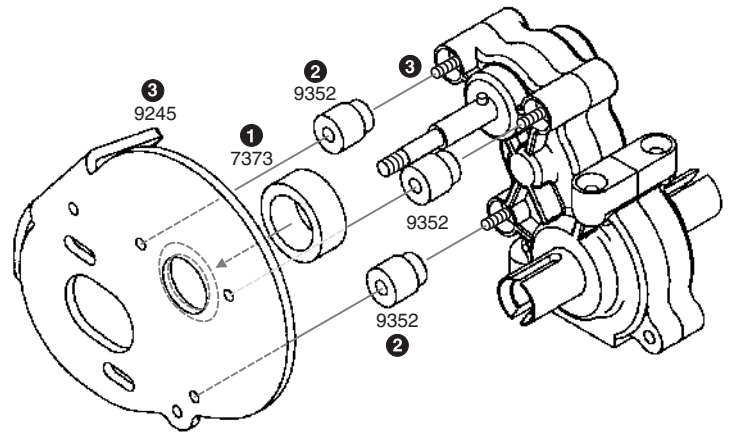

step 10

INSTALL THE ASSOCIATED TORQUE CLUTCH (ATC)

- 1 Add the #9251 inner hub to the shaft, lining up the notch with the roll pin.
- 2 Install the #9253 clutch disc into the inner hub, then add the #9252 outer hub and #6599 bushing.
- 3 Install parts in the following order: #6594 (thin), 6594 (thick), 6594 (thin), 6587 black spring, 6629 locknut.
- 4 Orient the #6693 spur gear side facing out as shown and mount to #9252 with two #6568 screws.
- 5 Tighten the #6629 locknut so the end of the shaft is flush with the end of the nut. This is a good initial adjustment.

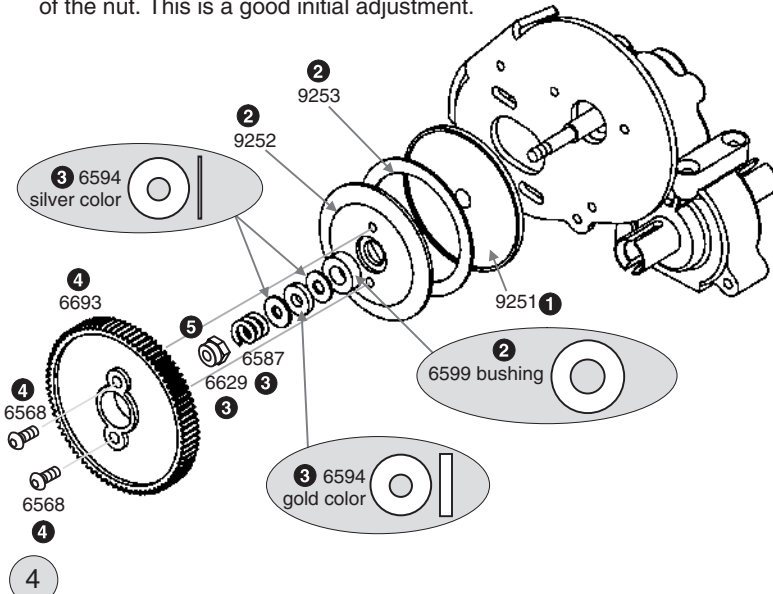

DIFFERENTIAL ADJUSTMENT

Once the differential has been correctly adjusted, there should be no need to change it until rebuilding time.

- 1 Tighten the diff screw down until the T-nut reaches the bottom of the diff hub slot or you feel the spring fully compressed. Do not overtighten. When you feel the spring fully compressed, loosen the diff bolt 1/8 of a turn. No more, no less.
- 2 On a new or just rebuilt differential, apply a small amount of throttle while holding one of the rear wheels stationary. Do this for about 10 seconds. This will correctly seat all of the differential parts.
- 3 Now recheck the differential adjustment by again following step 1 above.



TEAM ASSOCIATED
3585 Cadillac Ave.
Costa Mesa, CA 92626-1401

(714) 850-9342
fax (714) 850-1744
web: <http://www.teamassociated.com>