

TEAM ASSOCIATED

ae
Ready-To-Run

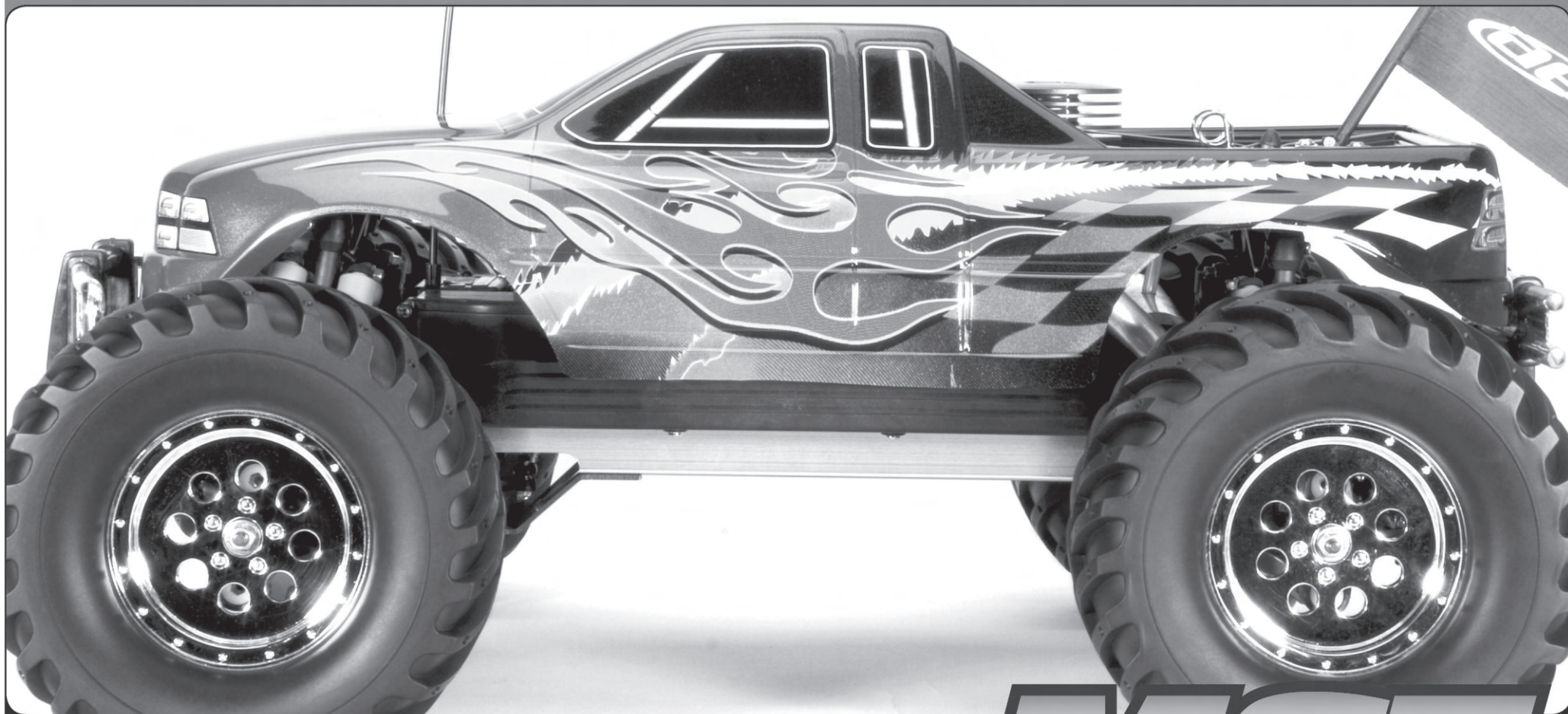

***Users Guide for the
MGT 4.60 SE***

***MGT
4.60 SE***



MGT 460 SE

Monster GT 460 SE #20501

Thank you for purchasing the Team Associated Monster GT. This User's Guide contains the steps you will use to prepare and use your new vehicle. Please read the entire manual before attempting to start your car to help reduce any problems on start up. We hope that you will enjoy your new Team Associated Monster GT!

The Monster GT is not intended for use by children without the supervision of a responsible adult. Associated Electrics, Inc. shall not be liable for any loss or damages, whether direct, indirect, special, incidental, or consequential, arising from the use, misuse, or abuse of this product and any chemical or accessory required to operate this product.

Contacting Us:

Customer Support
 Phone: (714) 850-9342, ext. 124
 Fax: (714) 850-1744
 Web Site: <http://www.rc10.com>

Associated Electrics, Inc.
 3585 Cadillac Ave.
 Costa Mesa, CA 92626 USA
<http://www.teamassociated.com>

Additional Equipment

Tools Supplied

MGT Hex Drive Starting Shaft
 MGT Nut Wrench
 Allen Wrenches (5 sizes - 1.5mm, 2.0mm, 2.5mm, 3.0mm, 5.0mm)



Helpful Items

Thread-Locking Adhesive (AE #1596)
 After Run Oil
 Needlenose Pliers

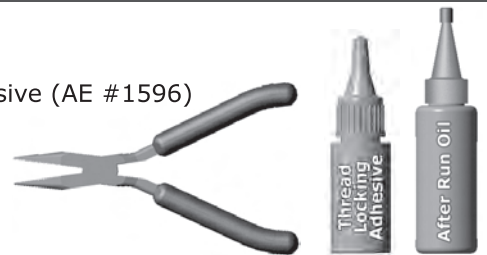

Items Required

Foam Pre-Filter Treatment (AE #7710)
 Fuel Bottle - 400cc (AE #1749)
 Glow Igniter - 110v (AE #1738)
 Slotted Screwdriver (AE #1552)
 Phillips Screwdriver (AE #1553)
 AA Batteries (12)
 Fuel (15%-30% only! See Fuel Selection on next page.)



Warning!

Do not use a power screwdriver to install screws into nylon, plastic or composite materials. The fast rotation speed can heat up the screws being installed. They can then break the molded parts or strip the threads during installation.

Visit Team Associated's Web Site For:

- New Products - added after this manual was printed.
- Tuning Tips - setting up your truck for superior handling.
- Customer Support - the answer to your question may already be posted.
- Body Painting Ideas - check out the Racer's Spotlight section for some cool paint schemes.
- Subscribe to our FREE Team Associated Insider's Newsletter - delivered right to your e-mail box!
- Hobby shop & track locations worldwide.
- Nitro engine troubleshooting tips.



2 Guidelines for Operation

CAUTION TIPS! Read this before you drive!

- Keep fingers away from all rotating parts while engine is running. Be aware of the rotating driveshafts on the underside of the truck. Use the handle or bumpers when picking up or turning over the truck.
- Nitro engines get VERY hot. Keep fingers and flammable items away from the exhaust pipe, exhaust header and from the top of the engine.
- Nitro fuel is poisonous, dangerous and highly flammable! Follow all the directions and heed all the warnings shown on the fuel container. **KEEP FUEL OUT OF THE REACH OF CHILDREN!**
- As do all gas engines, nitro engines can emit poisonous gasses. Run your truck ONLY in a well-ventilated area and do not run it indoors.
- Never drive your truck in a crowded area. Always maintain safe driving distance from spectators and yourself. Always leave a safety margin around the truck to help prevent collisions.
- Practice good ON 1ST - OFF LAST transmitter discipline. Always make sure that you turn on your transmitter BEFORE turning on your truck. Likewise make sure that you turn off your transmitter only **AFTER** stopping the engine and turning off your truck. This will help prevent a runaway accident.
- Weak transmitter signals and slow servos cause problems and accidents. Use fresh batteries in BOTH the transmitter and the receiver. If the red light is flashing on your transmitter or the servos seem sluggish on your truck, it's time to replace or recharge (NiCD and NiMH only) your batteries.
- Be aware of transmitter frequencies. Each transmitter and receiver pair comes with a numbered frequency crystal. If you are driving your truck in an area where other radio controlled vehicles are running, you will need to make sure that you are not on the same frequency as anyone else. This will help prevent runaway vehicles and glitches; either of which could result in injury or serious damage to your or someone else's property.

Tips for Engine Longevity

- Never allow the engine to overheat (260° F, measured at the glow plug; see included 4.60 AE Engine Manual for acceptable motor temperature ranges).
- Use only approved fuels. Fuels containing more than 20% nitro will run hotter and therefore reduce engine life.
- Do not run engine at full throttle for long periods of time. High engine speeds create more engine heat. Vary the engine speed.
- Do not use lean needle settings. Lean mixture settings will cause the engine to run too hot and decrease its life. Refer to the engine tuning section for proper adjustment.
- If your truck flips over, do not rev the engine! The engine will run until the tank is empty, even when upside down. Revving the engine will only cause excess heat in the motor.
- Keep the intake area clean. Clean and re-oil the filter at regular intervals.
- Do not drive the truck in deep or continuous water. If the engine becomes flooded by water, it will most likely need to be rebuilt.
- Use after run oil before you put the truck away for the day. This will keep the engine lubricated and fight corrosion. After run oil is available at most hobby shops.

Fuel Selection

- Choose a fuel from a reputable, brand name company that is approved for car/truck use. Do not use airplane or boat fuels in your truck.
- Choose a fuel that has a nitro content in the range 15%-30%. Lower nitro percentages will generally result in a cooler engine running temperature and therefore last longer before needing a rebuild; cooler-running engines also generally produce less power. 20% nitro is the most widely used fuel in these engines.
- Fuel color is for identification purpose only and is not important to performance or durability of your engine.



15% - 30% Nitro

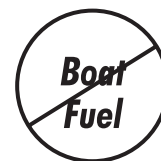

Oiling the Air Cleaner

When the air filter starts to get dirty, do the following steps:

- Clean the foam with dish soap & water. When it's clean, remove excess moisture with a towel & let the filter dry completely before oiling.
- Apply Associated's #7710 Foam Pre-Filter Treatment to help keep the dirt out. Dab a small amount of treatment all around the filter, put the filter in a plastic sandwich bag, and knead it until the filter is saturated, but not soaked.



3 Getting to Know Your Radio System

The Monster GT is equipped with a high quality 3-channel XP3 radio system. The following transmitter terms will be used throughout the rest of these operating instructions.

The XP Radio System

- Power Switch** – Switches your XP3 Radio ON and OFF.
- Steering Wheel** – Provides directional control of your truck.
- Throttle Trigger** – Provides throttle (pull) and brake (push) control of your truck.
- Forward/Reverse Button** – Toggles your truck's transmission between Forward and Reverse.
- Transmitter Antenna** – Transmits signals from your Transmitter. Always fully extend the Transmitter Antenna when you operate your truck.
- Battery Level Indicator** – Indicates the battery voltage level.
- Throttle HI ATV (Adjustable Throttle Volume)** – Allows you to preset the maximum travel of the throttle servo on the High side (throttle side).
- Throttle LO ATV** – Allows you to preset the maximum travel of the servo on the Low side (braking side).
- Steering Trim** – Adjusts the steering servo's center position to allow your truck to run straight.
- Throttle Trim** – Adjusts the throttle servo's center position to allow your engine to idle properly.
- Servo Reversing Switches** – Reverses the servo's rotation direction relative to your control input.
- Steering Dual Rate** – Limits the steering travel of your truck. A high setting increases the steering sensitivity of your truck while a low setting reduces the steering sensitivity.
- Transmitter Crystal** – Determines the frequency in which your radio transmits. Make sure that the corresponding Receiver Crystal has the same frequency as the Transmitter Crystal whenever you run.

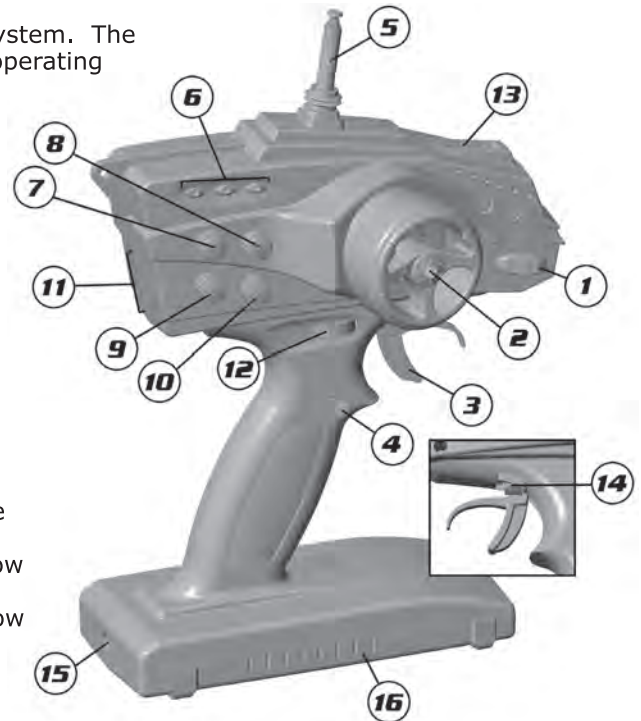

- Trigger Neutral Position Lever** – Allows the neutral position of the Throttle Trigger to be changed.
- External Charging Jack** – Allows the Transmitter Batteries to be recharged using an optional charger. Use only with rechargeable NiCd or NiMH batteries. Do not use with Alkaline or Standard cells.
- Battery Cover** – Holds your Transmitter's batteries in place.

Preparing Your Radio System

- Install Transmitter Antenna.
- Install Transmitter Batteries. Requires 8 AA Batteries.
- Install Receiver Batteries. Requires 4 AA Batteries.

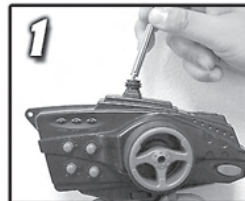

Testing Transmitter & Truck

- Switch ON the Transmitter and extend the Transmitter Antenna. You should see the Battery Level Indicator light up showing that the radio is ON.
- Switch ON the Receiver switch. All the servos should move to their respective neutral settings.
- Turn the Steering Wheel left and right. This will turn the truck's front wheels left and right (as viewed from the rear of the truck).
- Pull the Throttle Trigger. This will open the throttle on the Carburetor.
- Release the Throttle Trigger. This will return the Carburetor back to its closed position.
- Push the Throttle Trigger. This will activate the brakes.
- Press the Forward/Reverse Button. This will shift the truck into Reverse. Press the Forward/Reverse Button again to shift the truck into Forward.
- Set the truck on the ground. Pull the Throttle Trigger and give the truck a push. The truck should roll freely. While it is still rolling, push on the Throttle Trigger to activate the brakes. The truck should come to an immediate stop. If these steps do not produce these results, refer to the Adjustments Section under Linkage Setup.

Frequency Crystals (Channels)

The 27MHZ Frequency Band is divided into 6 Channels so that up to six different vehicles can be operated simultaneously. The XP3 Radio System includes one of these six Channels, in the form of a pair of Crystals; one for the Transmitter and one for the Receiver. Should you choose to run two Monster GT's, you will need to check to make sure both trucks are NOT on the same Channel. The chart below lists the channels and their flag colors.

27MHZ	Flag Color	Channel	AE Part #
26.995	Brown	1	29108
27.045	Red	2	29109
27.095	Orange	3	29110
27.145	Yellow	4	29111
27.195	Green	5	29112
27.255	Blue	6	29113

4 Getting to Know Your Truck

Please take a few moments to familiarize yourself with the Monster GT. The pictured truck below highlights only a few of the exciting features we have included with your new truck. Many hours have been spent making sure this is one of the Biggest, Fastest, and Toughest trucks available!

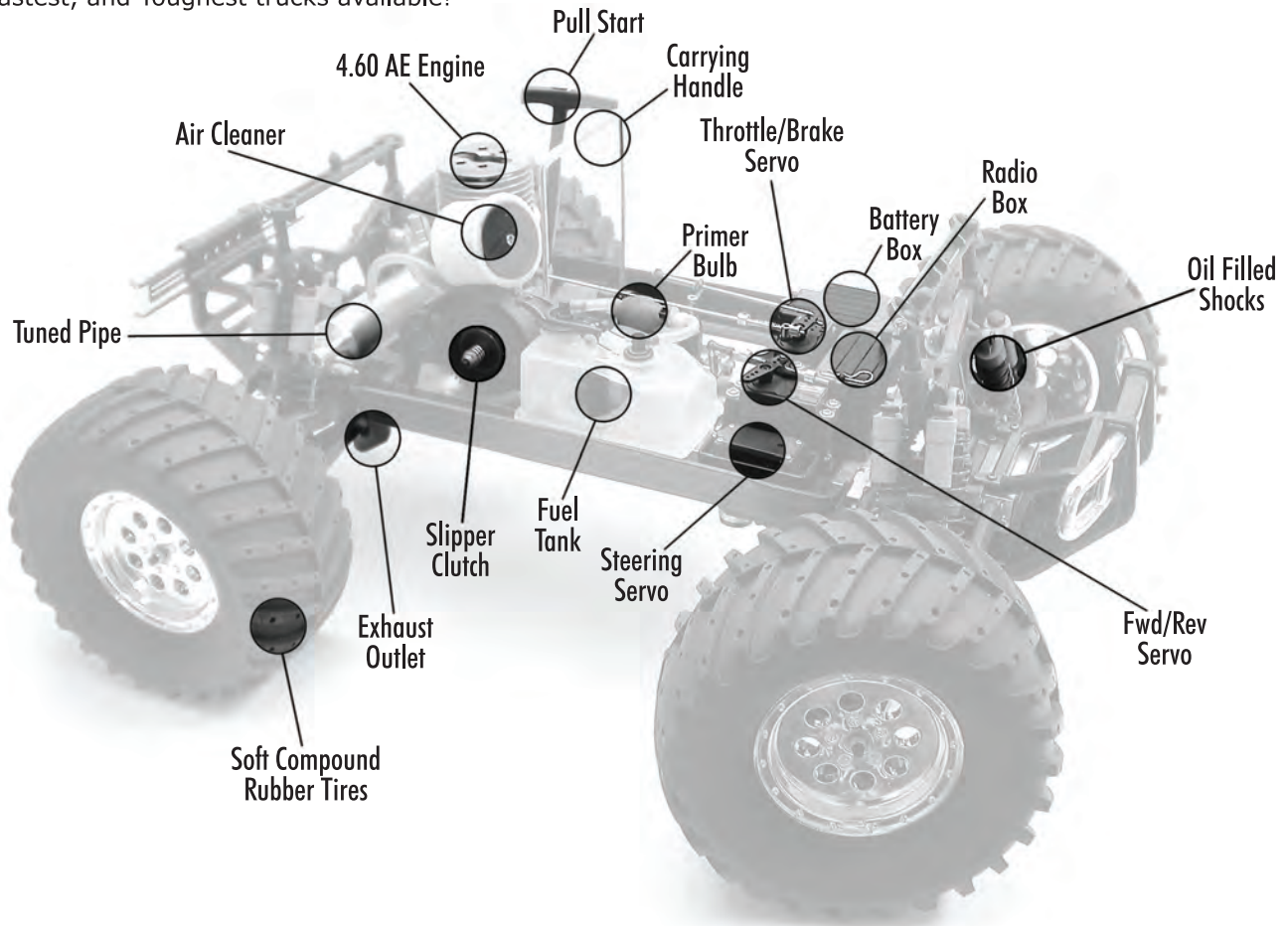

5 Shutdown Procedures

Make sure that you have read and understand the shut down procedure before starting the truck!

1. Bring your truck to a complete stop and idle.
2. Remove the body clips and body.
3. Using needle-nose pliers or a clothespin, pinch off the fuel line just before the carburetor until the engine stops (1-2 seconds).
4. **DO NOT ATTEMPT TO STOP THE MOTOR BY TOUCHING OR GRABBING THE FLYWHEEL!** These motors have a lot of torque and serious injury could occur from stopping the engine in this manner.
5. The exhaust gasses can be very hot, stopping the motor by plugging the exhaust with your finger could result in a serious burn.
6. Turn off your truck at the battery box.
7. Turn off your radio.

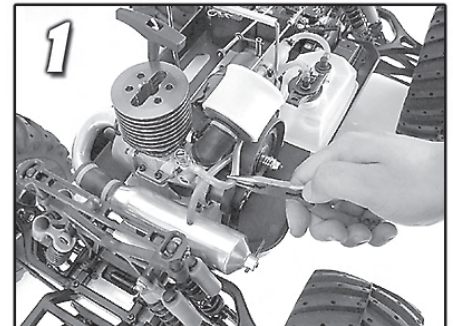

6 Starting Your Truck

1. Have fresh batteries or a full charge (for rechargeable NiCd and NiMH versions) in your glow plug igniter.
2. Make sure that your radio system (transmitter and receiver) is ready (See section on transmitter settings and use).
3. Remove the truck body.
4. Add Fuel to the Fuel Tank.
 - 4.1. Use a squeeze bottle to safely and easily transfer fuel to the tank.
 - 4.2. Fill the tank no higher than the bottom of the neck.
5. Turn on the transmitter.
6. Turn on the receiver switch.

7. Prime the carburetor:

- Squeeze the primer bulb completely once.
- Slowly squeeze the primer bulb again while watching the fuel come through the line.
- Repeat the above step until the fuel just reaches the carburetor inlet (see figure).
- Carefully give the bulb another ¼ squeeze (1/8th inch). **BE CAREFUL NOT TO SQUEEZE TOO MUCH** or the engine will become flooded. Attempting to start a grossly flooded (or hydro-locked) engine (full of fuel) can cause serious damage to internal engine parts.

8. Put the glow plug igniter on the glow plug and make sure that it is seated properly.

9. Start the truck using either the pull-start or hex start (cordless drill required).

Fuel to here then add 1/4 squeeze of primer bulb.

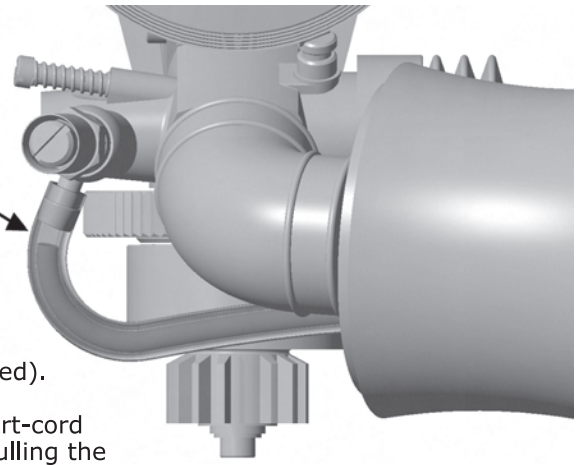

Pull Start - Hold the truck by the handle with one hand and pull the pull-start-cord with the other. Use quick and short pulls and make sure that you are only pulling the cord about 5-7 inches. Pulling the cord more than 8 inches or all the way will damage the pull-start mechanism. If the cord is difficult to pull or is stuck it is an almost sure sign that the engine is flooded.

Hex Start - Make sure that your drill is set to the clockwise or forward position. Insert the Hex Starting Shaft to the drill and tighten the drill's chuck with the ball end facing away from the drill. BEFORE inserting the Hex Starting Shaft into the dual start output, squeeze the trigger and verify that the drill is turning the same direction as is shown on the sticker on the pull start cover. **WARNING - Attempting to start the motor by using a counter-clockwise direction could damage the pull-start mechanism or possibly the engine's internal components!** Insert the ball end of the Hex Start Shaft into the Dual Start output. Grasp the drill tightly and squeeze the trigger.

- If the engine becomes flooded: Turn off your truck, and then the radio.

Remove the glow plug using a glow plug wrench and then remove the air filter. Turn the truck over to allow any excess fuel in the engine to run out. Turn the truck right side up. Reinstall the air cleaner. Slowly pull the pull-start cord about 7 inches, 5 to 7 times. Reinstall the glow plug with the glow plug wrench. Return to step 7.

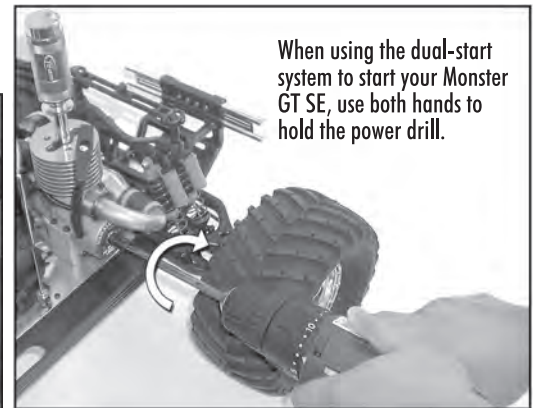
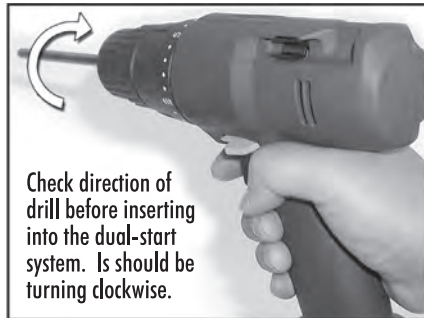

10. Continue to pull the cord or squeeze trigger on the drill until the engine starts. If the engine still does not start, try giving the primer bulb another ¼ squeeze. If the truck still does not start, check the glow plug (see section 6 of the engine manual).

11. Remove igniter from the glow plug.

12. Install the truck body and body clips.

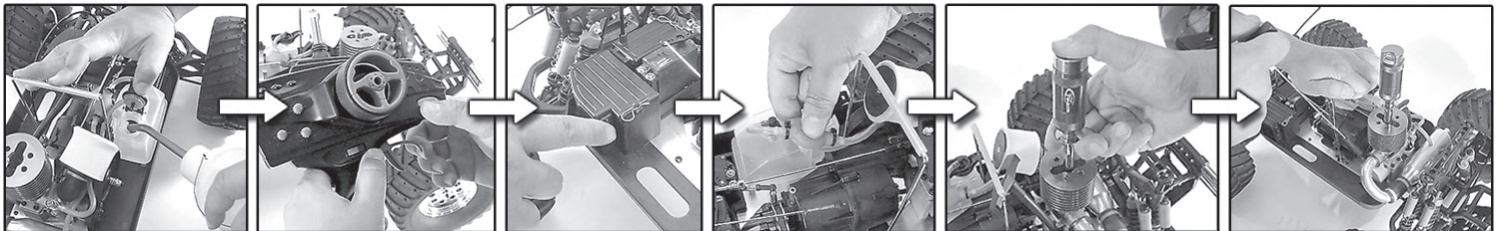

7 Driving & Storage Tips

Operating/Driving Tips

- Your truck is just that, a truck. Therefore, by design, it has a high center of gravity and will require slower cornering speeds to keep from rolling over.
- Forward and reverse use
 - Make sure that the truck has come to a stop before shifting directions.
 - Press the reverse button on your radio located near your thumb (see radio section).
 - Throttle and brake actuation work in the same directions as when the car is in forward gear (pull trigger for throttle, push trigger for brake).
 - Stop the truck when you would like again to return to normal driving.
 - Press the reverse button.
- Your truck has a two-speed transmission. The transmission can be thought of as an automatic transmission that is

designed to shift when the truck is traveling at a certain set speed. Refer to the "Adjusting the two-speed" section in this manual to adjust that set point or if your truck does not appear to be shifting correctly.

- The electronic components on your truck are in compartments to keep them from malfunctioning because of dirt and debris build up. **The servos and the compartments housing the electronics are not waterproof.** Driving through water could cause damage and/or malfunction to occur.
- Follow all the caution tips listed in this manual and USE COMMON SENSE! Abusive and rough driving could result in broken parts.
- The Monster GT can be carefully refueled while the engine is running to extend the run time.

Storing your truck

To keep your truck in good working condition, there are a few steps that need to be followed:

1. Remove the fuel from the tank. Both your truck and squeeze bottle should always be stored free of fuel.
 - Empty any fuel remaining in your squeeze bottle back into the fuel container.
 - Draw the fuel in the fuel tank into the squeeze bottle and squeeze it back into the fuel container.
 - Repeat the above step as necessary until the tank is as empty as is possible.
 - Make sure to store your fuel container out of the reach of children in a cool, dark location and make sure that the lid is securely tightened.
2. Put the glow plug igniter on the glow plug, hold the carburetor all the way open and pull the pull-start a few times. This will make sure that there is no unused fuel in the engine or fuel lines.
3. Use after run oil.
 - Start out by taking an old toothbrush and cleaning off the dirt around the base of the filter. This will help to keep grit out of your engine.
 - Remove the filter from the carburetor.
 - Place 2-6 drops (as recommended by after run oil manufacturer) directly into the open carburetor.
 - Slowly pull the pull-start cord about 8 inches, 3-5 times.
 - Reinstall the air cleaner.
4. Clean your truck – storing it dirty can lead to a gummy build up and poor performance.
 - Use nitro car cleaner, WD-40 or equivalent to clean up the dirt and oil.
 - Use an old toothbrush or a small paintbrush to get to the hard to reach areas.
 - A damp cloth works well for cleaning the body. Stubborn dirt and oil on the body is best removed with any diluted organic solvents (Simple Green, etc).
5. Lubricate the wheel bearings, drive axle joints, clutch bell bearings and suspension pivots using thin oil.
6. Verify that BOTH the radio and receiver switches are turned off. It is very disappointing to have dead batteries next time you want to run your truck.

8 Adjustments

Two-Speed Adjustment

1. Your truck's two-speed shift point is preset from the factory. It should shift into 2nd gear within **12-15** feet on a full throttle, standing-start acceleration.
2. If you wish to adjust the shift point, first **shut down the engine** then open the two-speed access cover on the transmission case. Align the **BLACK adjustment set screw** with the opening on the 2nd gear as shown on the diagram.
3. Using a **2mm Allen wrench**, turn the black adjustment set screw **clockwise to make the two-speed shift later**; turn it **counter-clockwise to make the two-speed shift earlier**. Only use ¼ turn increments whenever you adjust your two-speed.
4. Close the two-speed access cover on the transmission case.
5. Be careful not to touch any **hot engine components** in the area.

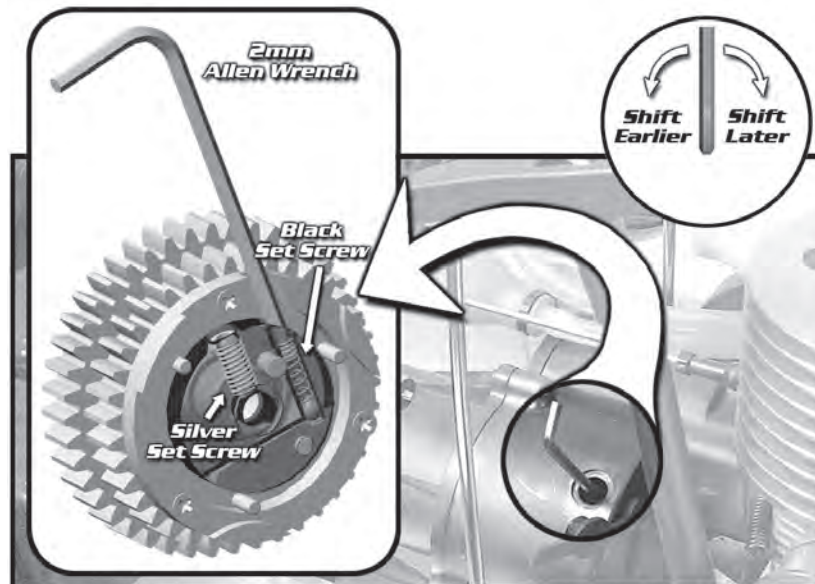

Front & Rear Toe-In / Toe-Out

1. Use a **1.5mm Allen wrench** as shown to adjust the front & rear toe-in.
2. Lengthening the **Turnbuckles** will increase the amount of toe-in, shortening them will increase the amount of toe-out.
3. The **notch** on the turnbuckle indicates the side that has the **right-hand thread**. Use it as a guide to determine which way to turn the turnbuckle when adjusting its length.

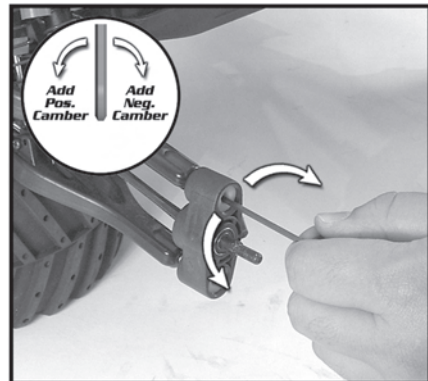

Front & Rear Camber

1. Use a **2.5mm Allen wrench** as shown to adjust the front & rear camber.
2. Turning the upper pivot ball clockwise increases camber towards the negative side; turning it counter-clockwise increases camber towards the positive side.

Ride Height

1. The truck's ride height can be increased by adding preload clips to the shocks. Removing preload clips will decrease the ride height.
2. Compress the spring and insert the preload clips between the spring collar and the shock body flange.

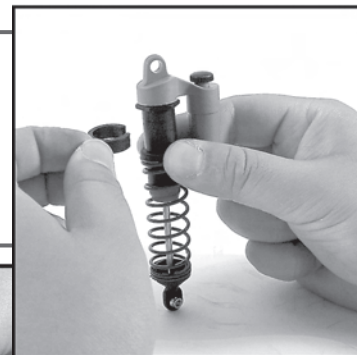

Slipper Clutch

1. Use a **7mm nut driver** to adjust the slipper clutch.
2. Tighten the slipper nut until the spring is fully compressed.
3. Once you've reached the point where the spring is fully compressed, loosen the slipper nut 1/4 turn.
4. Do not run your truck with the slipper nut any looser than 1/4 turn from full spring compression. Setting the slipper too loose may result in a damaged spur gear.

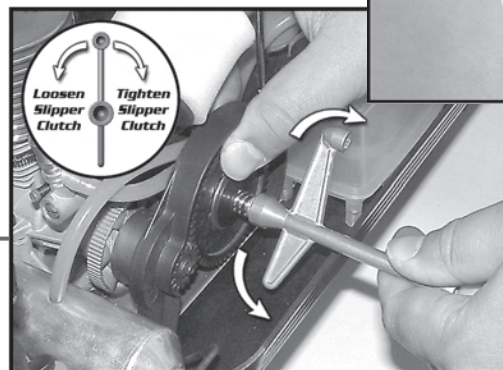

Radio Adjustments

1. **Dual Rate** – Push the dial to the right to increase the amount of steering throw for a tighter turning radius; push the dial to the left to decrease the amount of steering throw for a larger turning radius.
2. **Steering Trim** – Start the truck and drive it forward slowly with no input on the steering wheel. If the truck veers to the right, turn the Steering Trim knob to the left until the truck runs straight. If the truck veers to the left, turn the Steering Trim knob to the right.
3. **Throttle Trim** – With the engine running, the truck should remain stopped (on level ground) when the throttle is in neutral. At the same time the truck should roll freely in both forward and reverse directions. If the truck creeps forward, turn the Throttle Trim knob to the left just enough so that the truck stops moving. If the truck doesn't roll freely turn the Throttle Trim knob to the right just enough to disengage the brakes.
4. **Throttle HI ATV** – Perform this adjustment only with the **engine OFF** and the **radio system ON**. Remove the air filter from the carburetor and turn the Throttle HI ATV knob all the way to the left. Pull the throttle trigger all the way to full throttle and look into the carburetor. You'll see that the slide valve is not open all the way. Now start turning the Throttle HI ATV knob to the right until the slide valve fully opens. Do not adjust the Throttle HI ATV past the point where the valve is fully open because it will strain the throttle servo.
5. **Throttle LO ATV** – You can use this adjustment to limit your truck's braking power. Turning the Throttle LO ATV to the right gives you more braking power; turning it to the left gives you less braking power.

Linkage Reference Pictures

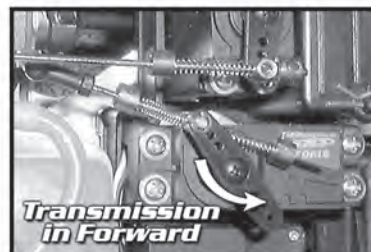
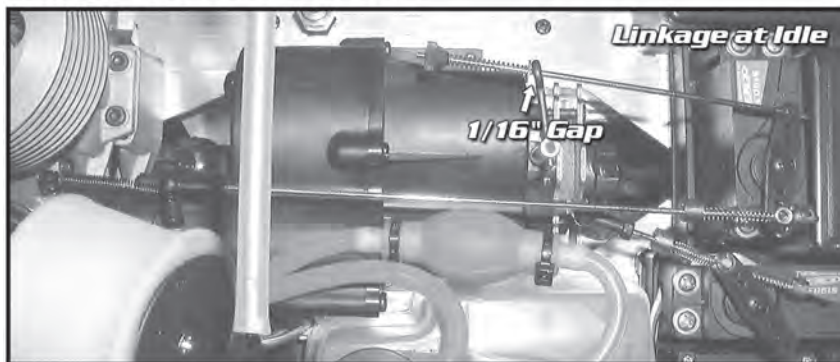

Adjusting throttle, brake, and FWD/REV linkages

Your truck comes with linkages that are pre-set. At some point it may be necessary to adjust or replace the linkages that connect the servos to the throttle, brake, and/or transmission. See pictures above for reference.

1. Throttle linkage adjustment

- Loosen the setscrews of the collars using a 1.5mm Allen driver.
- Turn on your radio and truck but do not start the engine.
- Move the forward collar so it is just in contact with the pivoting linkage collar on the servo horn and tighten the setscrew.
- Move the rearward collar and spring so the spring is just in contact with the pivoting linkage collar and tighten the setscrew.
- Verify motion of the linkage by moving the throttle trigger through its full range of motion.
- Make small adjustments using the throttle TRIM and throttle High ATV if necessary.

2. Brake linkage adjustment - only make this adjustment after the throttle linkage has been set up correctly!

- Turn on the radio and the truck, but do not start the engine.
- Leave the throttle trigger on the radio set at the neutral setting.
- Hold the brake lever so the brake is engaged (minimal pressure) with one hand.
- Using your other hand, turn the plastic brake adjustment nut at the end of the linkage until there is a 1/16" (1.5mm) gap between the spring and the brake lever when the spring is not compressed.
- Verify motion of the linkage by pulling the throttle on the radio to full throttle and pushing it to full brakes, check to make sure that there is full actuation of the slide carburetor and the brake lever.
- While holding the trigger to full brakes, try to roll the truck forward and backward. It should not roll.
- Make small adjustments using the throttle TRIM and throttle High ATV if necessary.

3. FWD/REV linkage adjustment

- Loosen the setscrews of the collars on the wire linkages using a 1.5mm Allen driver.
- Turn on the radio and the truck, but do not start the engine.
- The servo will move automatically to the position for forward driving.
- Move the rearward collar toward the pivoting linkage collar on the servo horn until the spring is fully compressed. Uncompress the spring about 3/16" (4.5mm) by sliding the collar back and then tighten the setscrew.
- Press the FWD/REV button on the radio.
- Repeat step 3.4 with the forward collar.

Shock Springs



Stiffer springs will give you better handling and higher cornering speed on smooth surfaces such as asphalt, concrete, and hard pack dirt. Soft springs are better for rougher terrain, rock crawling and jumping. Softer springs will increase the rollover tendency of the truck at higher speeds.

AE Part #	Spring Color	Rate	Relative Stiffness
25062	Blue (std)	4.40lb/in	Softest
25063	Gold	5.10lb/in	↓
25064	Red	5.95lb/in	
25065	Copper	6.90lb/in	Stiffest

Optional Gearing

Additional gearing is available for your Monster GT. Additional gearing allows you to match your engine and transmission to your driving situation. Bigger gears on the clutch bell (or smaller slipper gears) will result in greater top speed, but will have slower acceleration from a stop (see chart below). If you change the gearing you will need to reset the gear mesh:

- Loosen (or tighten if engine was removed) the four engine mounting bolts located on the underside of the truck until you can just slide the engine forward and backward.
- Slide the engine up to the spur gear until the teeth on the clutch bell are meshed tightly with the teeth on the slipper gear.
- Move the engine back a little bit (1/32" or 0.8mm). Check the mesh by holding the smaller gear with one hand and rocking the bigger gear back and forth with the other. The big gear should rock back and forth slightly with little effort. A gear mesh that is too tight will be noisy, have lower performance and could ruin the gears.

Clutch Bell Gear Size	Slipper Gear Size	Final Reduction 1st Gear	Final Reduction 2nd Gear	 Better Acceleration Higher Top Speed 
14 AE #25370	52 (kit) - AE #25038	30.17	20.87	
	49 - AE #25378	28.46	19.68	
	46* - AE #25379	26.75*	18.50*	
15 AE #25155	52	28.22	19.51	
	49	26.59	18.39	
	46	24.97	17.27	
16 (kit) AE #25372	52	26.43	18.28	
	49	24.88	17.21	
	46	23.42	16.20	
17 AE #25373	52	24.88	17.21	
	49	23.42	16.20	
	46	22.04	15.24	
18 AE #25374	52*	23.42*	16.20*	
	49	22.04	15.24	
	46	20.82	14.40	

*Some gear combinations may require modification of the spur gear support guard. Look for equivalent ratios to avoid making modifications. For example, instead of using the 18-52 combination, choose either of the 17-49 or 16-46 combos.

Air Filter Elements

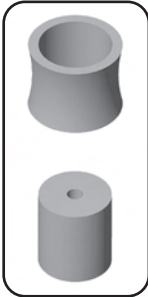

x3 25078

Option:
Foam
Prefilter
Treatment
#7710

Pipe

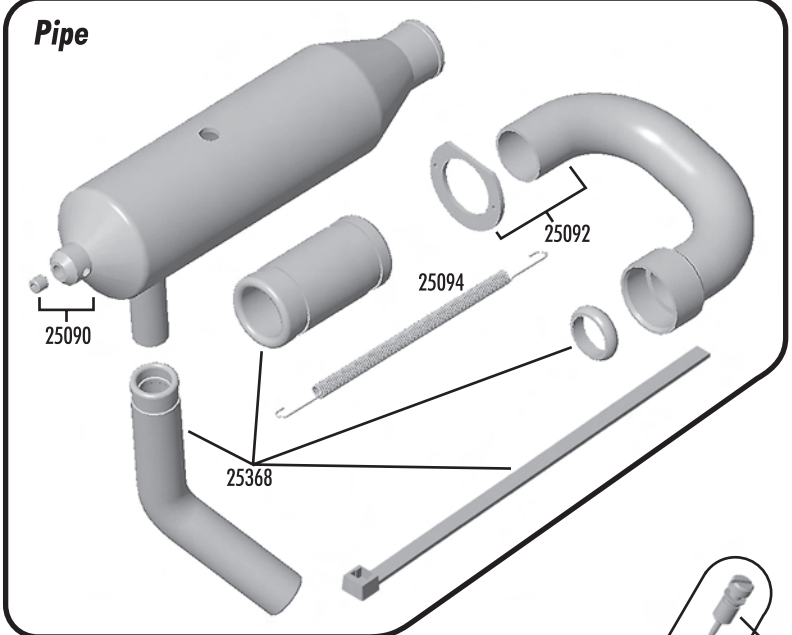

25090
25092
25094
25368



25327

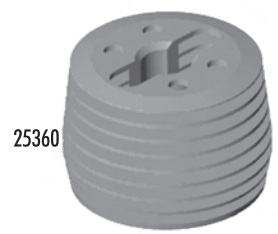

25360



25361

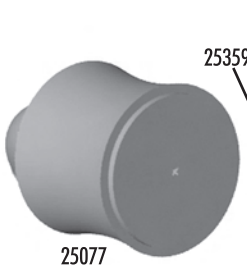

25077

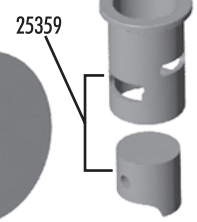

25359



25309

25358



**Complete Engine
#25354**

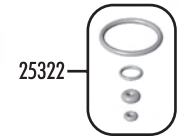

25322

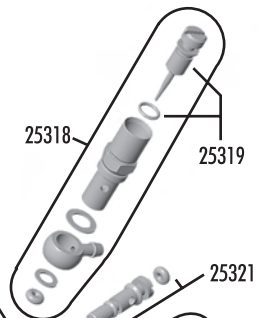

25318

25319

25321

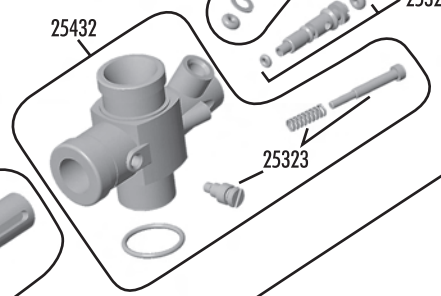

25432

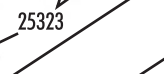

25323



25357



25364

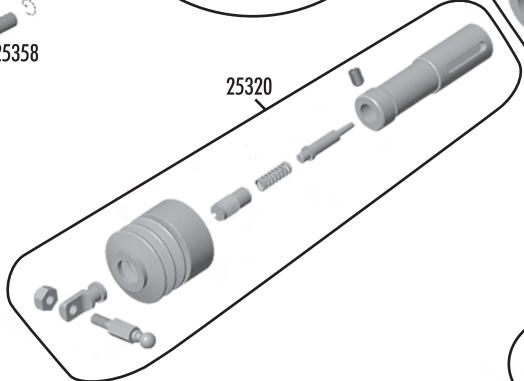

25320

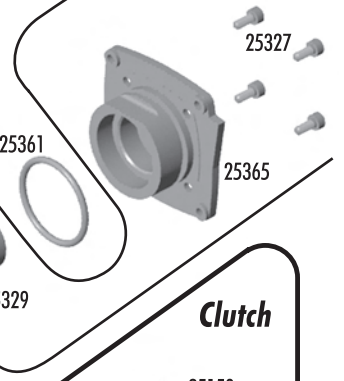

25327

25361

25365

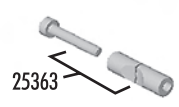

25363

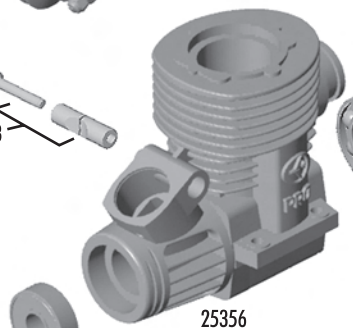

25356



25355

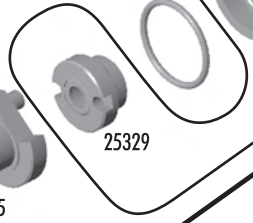

25329

Clutch



25150



25148



25237



25146



25155



25147

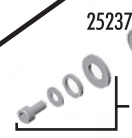

25237

25152



25149



Pull Start

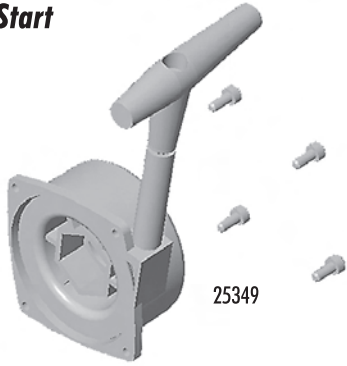

Tank, Fuel Tubing & Primer Bulb

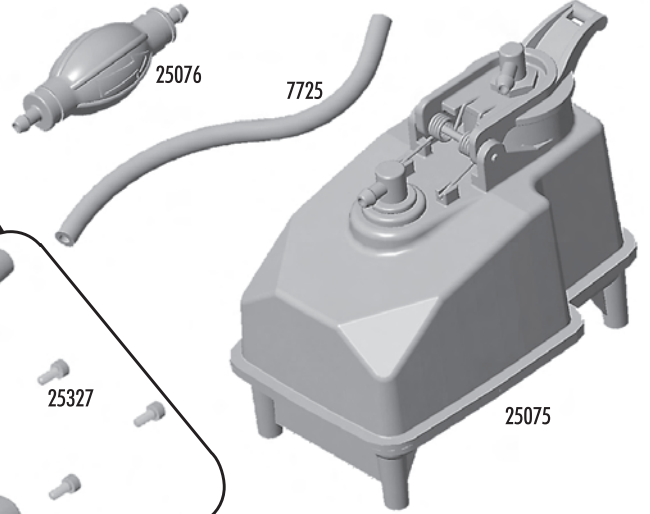

Backplate



25366

25343

25331

25327

25353

25339

25335

25341

25361

25330

25333

25164

Radio Box

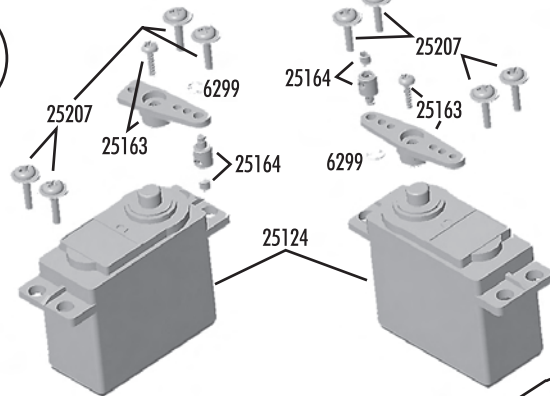

25165

6338

25160

25180

6332

29126

25207

25162

29123

6332

29117

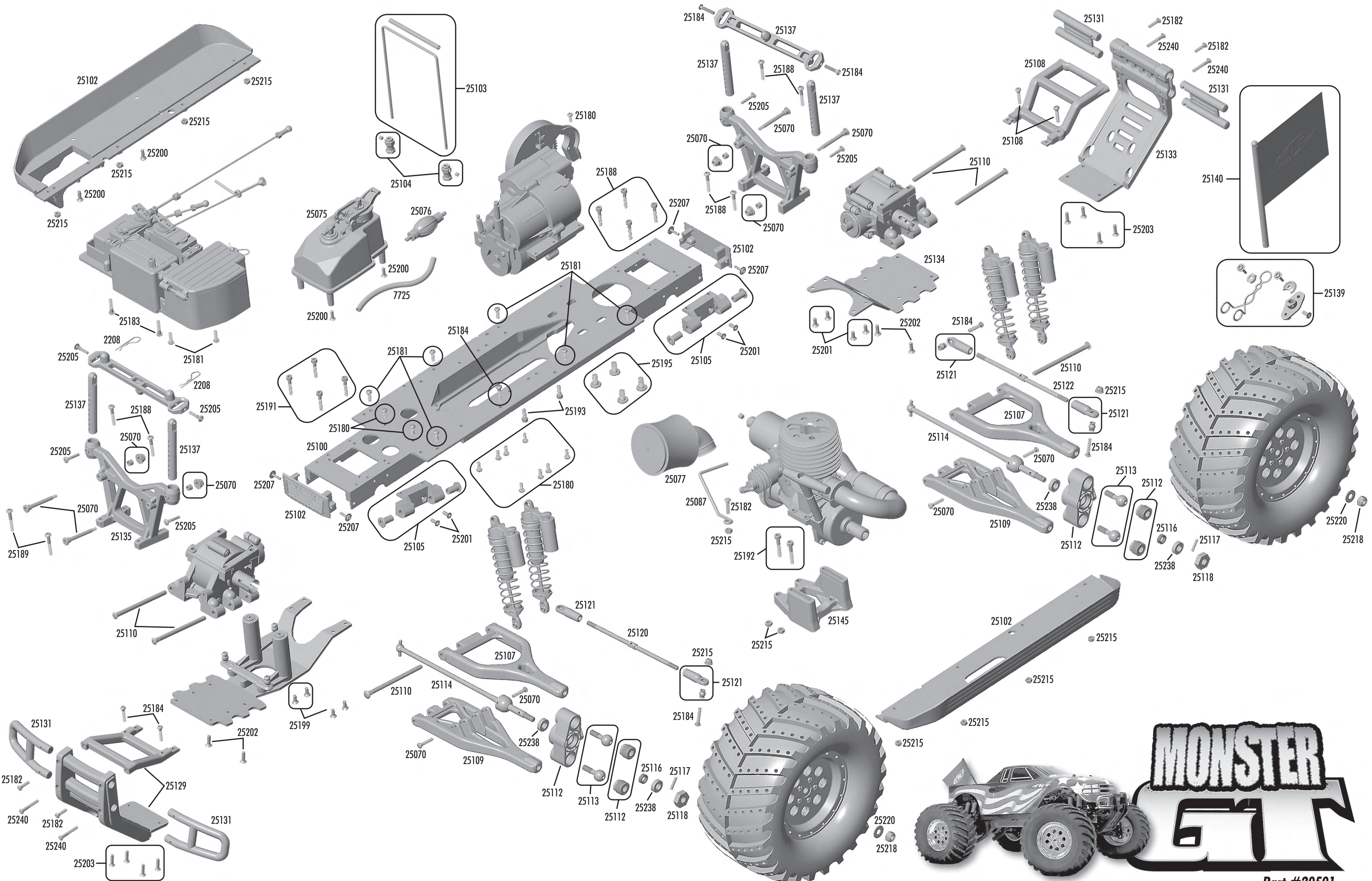

Steering

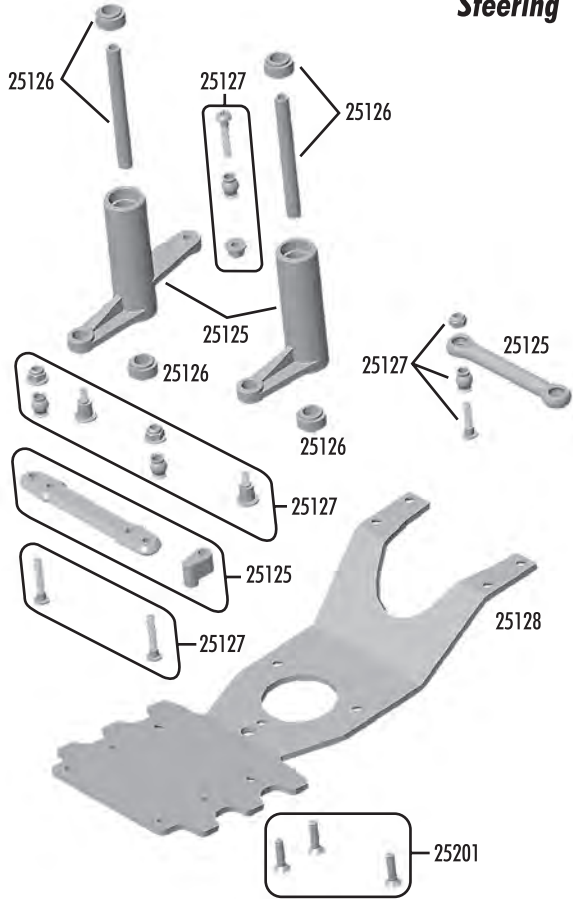

Option:
Locking
Adhesive
#1596



CVA Rebuild Kit: #25055
Universal Drive Rebuild Kit: #25115
Drive Cup Screw (separate): #25056

CVA

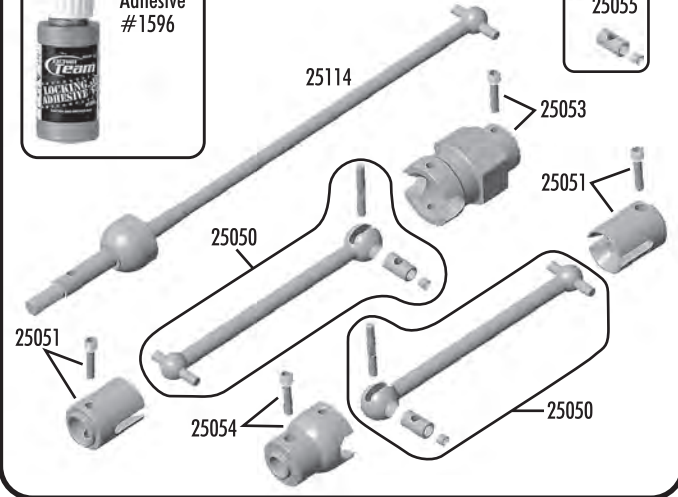

Optional Forward Only Conversion Kit



Tires & Wheels

Option:
Tire Adhesive
#1597

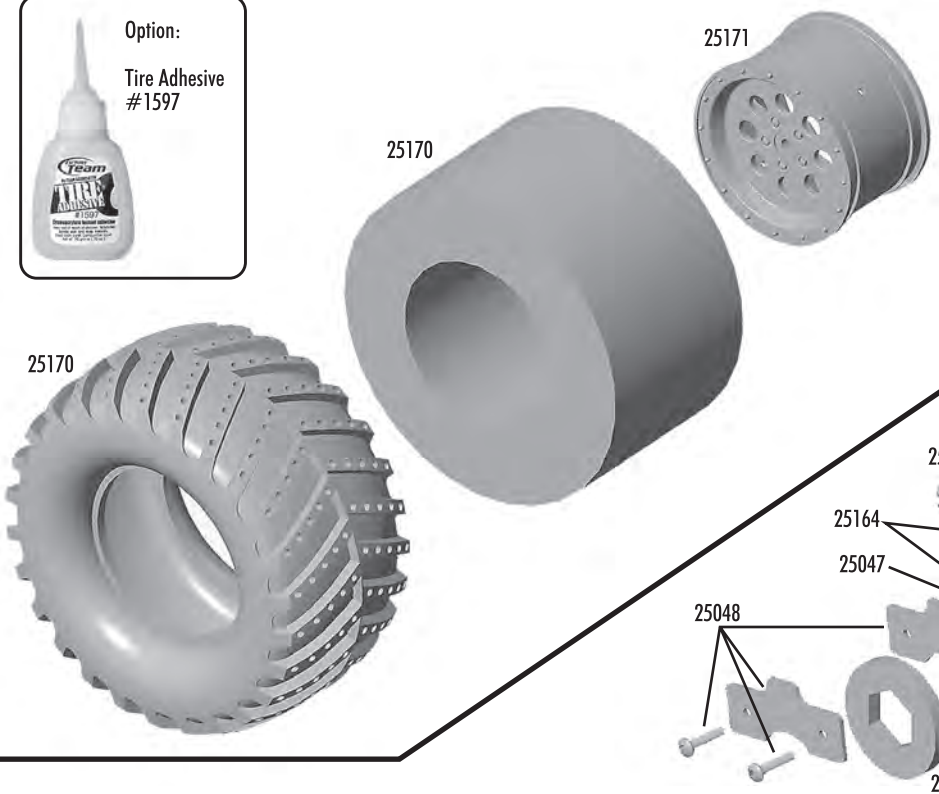

Got Questions?

If you any questions or concerns, please
call Team Associated's Customer Service
at 714.850.9342!



Shocks



Shock Rebuild Kit
#25061

Replacement Shock Set,
Assembled (8): #25058

Replacement Shock Set,
Assembled (2): #25059

Optional Shock Springs
Blue, Soft (4): #25062
Gold, Medium (4): #25063
Red, Firm (4): #25064
Copper, Extra Firm (4): #25065



Front/Rear Gearbox

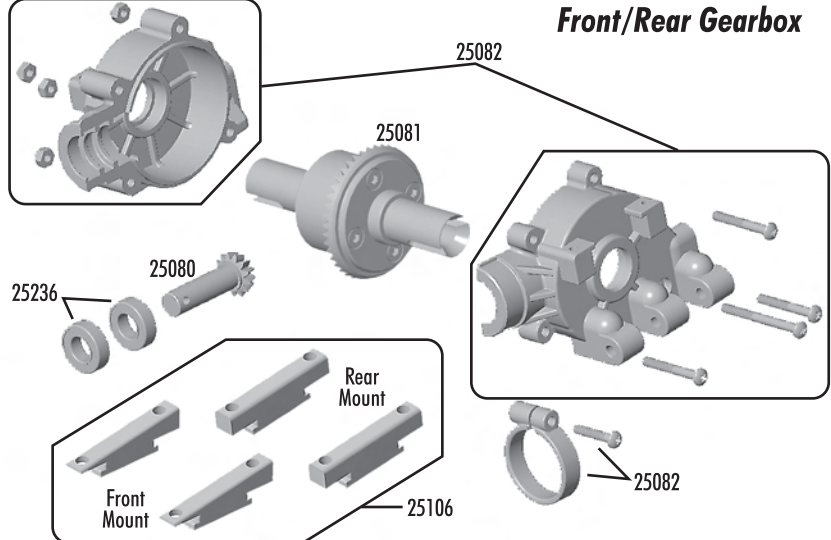

Center Transmission

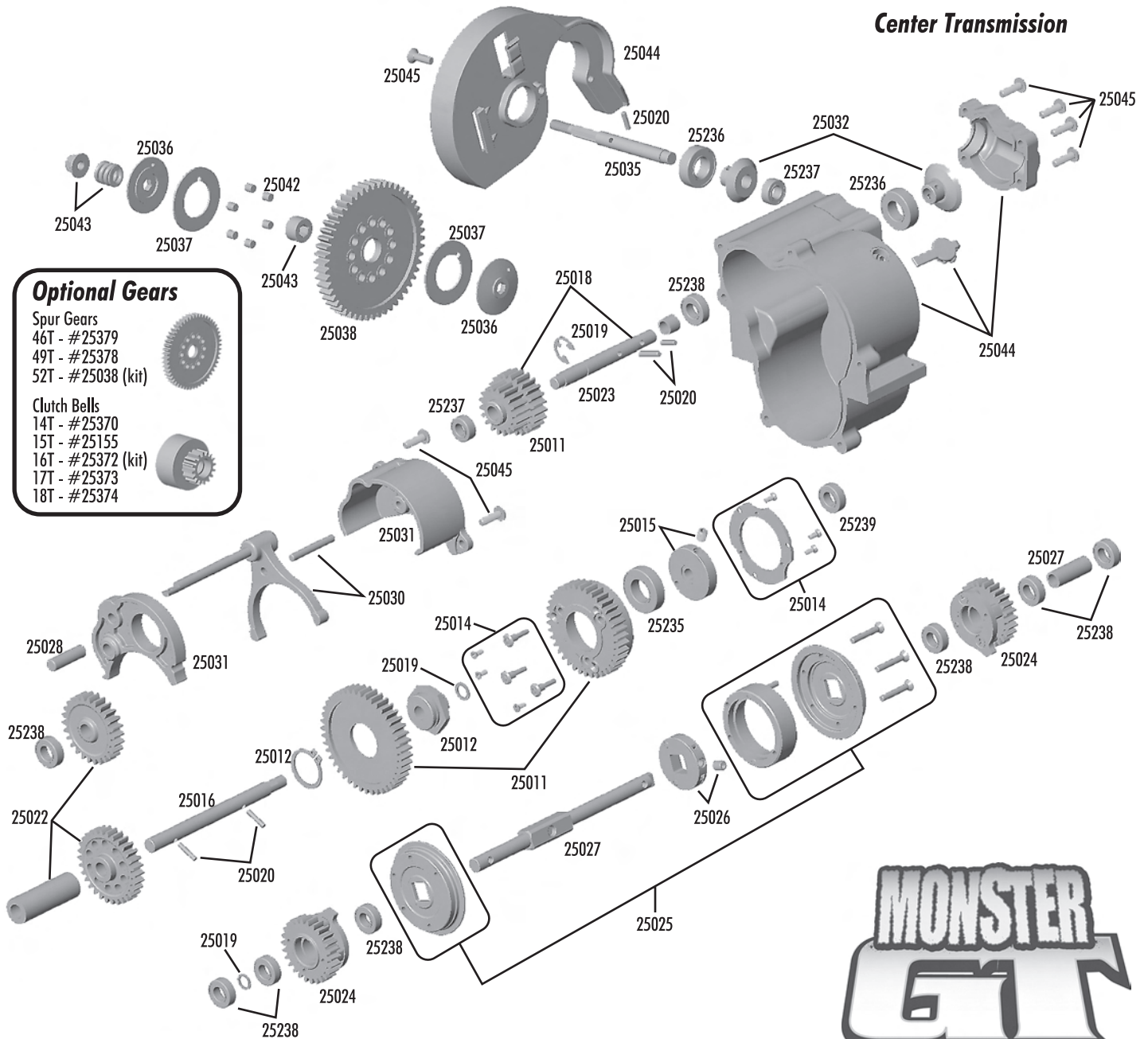

Optional Gears

Spur Gears
46T - #25379
49T - #25378
52T - #25038 (kit)

Clutch Bells
14T - #25370
15T - #25155
16T - #25372 (kit)
17T - #25373
18T - #25374



Section 1:

Removing the Front Gearbox

Follow these steps to remove the front gearbox from the truck.

Required Tools:



Phillips Screwdriver
(AE #1553)



MGT Nut Wrench
(AE #25260)



3/32" Allen Driver (AE #1546)

5/64" Allen Driver (AE #1545)

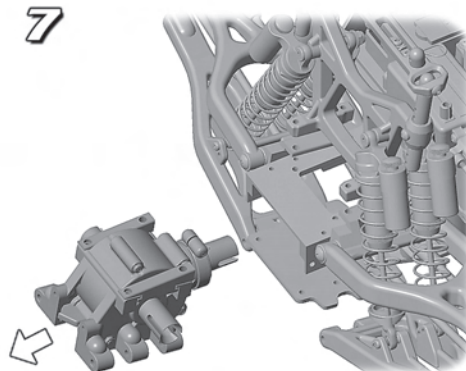
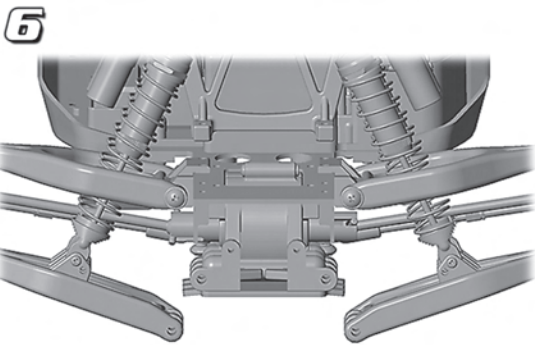
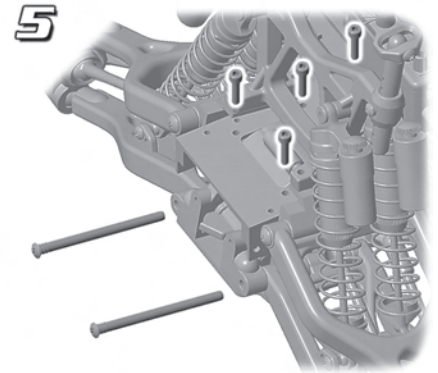
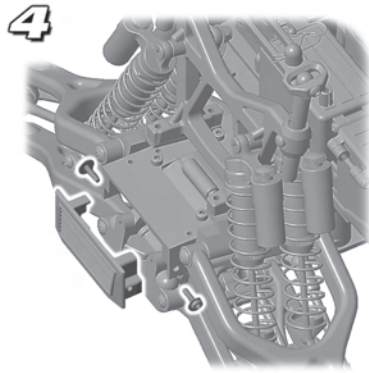
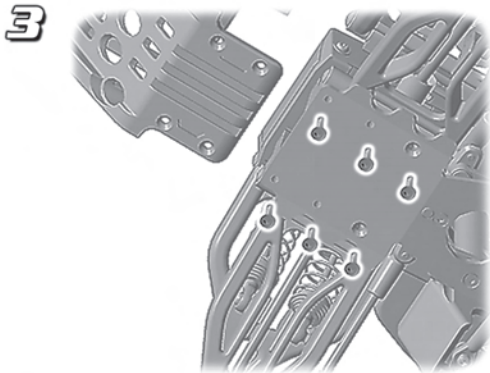
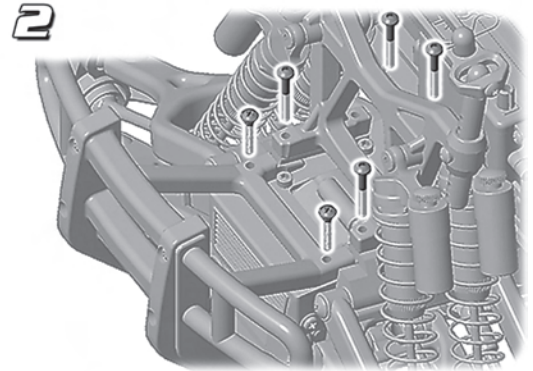
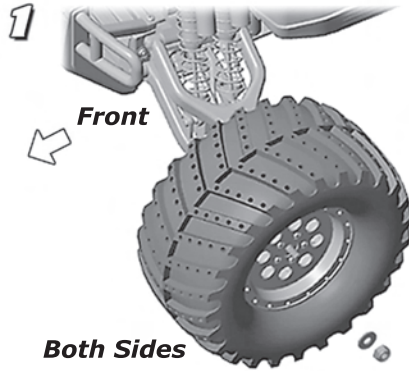

Section 1:

COMPLETE!

Refer to Section 5 for instructions on rebuilding your gearbox.

Section 2:

Removing the Rear Gearbox

Follow these steps to remove the rear gearbox from the truck.

Required Tools:



Phillips Screwdriver
(AE #1553)



MGT Nut Wrench
(AE #25260)

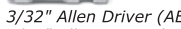

3/32" Allen Driver (AE #1546)

5/64" Allen Driver (AE #1545)

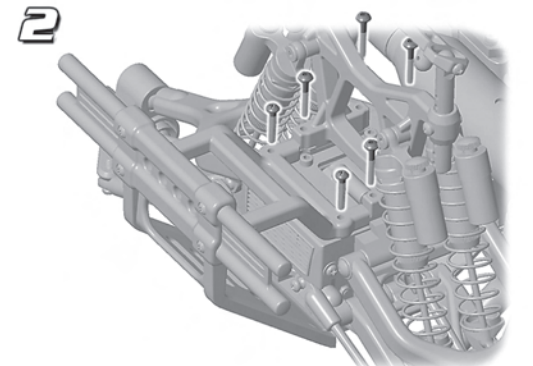
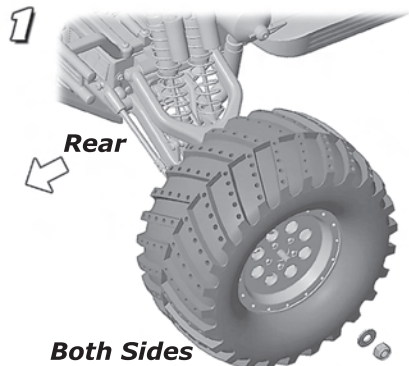

Building Tips

After removing the screws from the truck, set them in separate piles. This will aid in rebuilding the truck with the correct screws in the correct locations.

When re-installing screws into the plastic parts, turn the screw counter-clockwise until it 'falls' into the original threads. This will help prevent the screw from forming new threads and stripping out the plastic.

Thread locking compound should be used on all screws that tighten into aluminum or metal parts. This will help prevent them from loosening during vehicle operation.

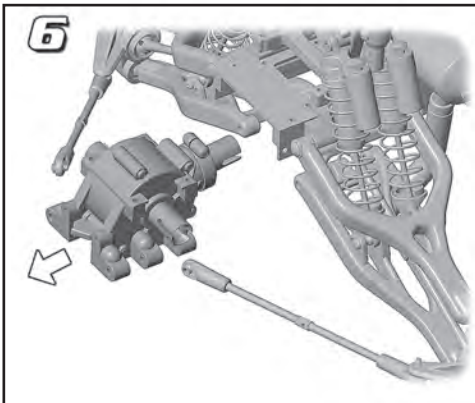
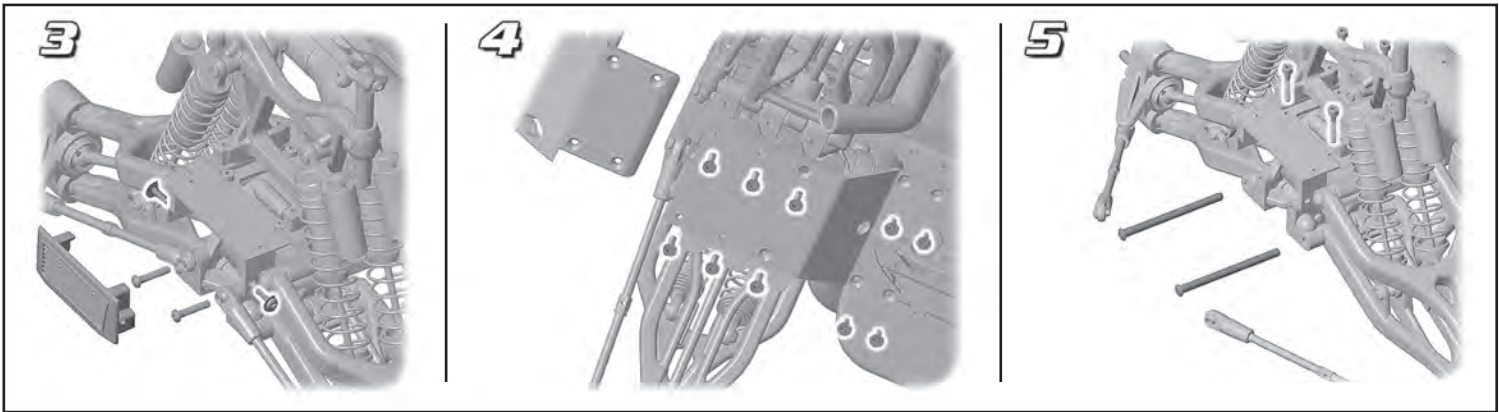

Section 2:

COMPLETE!

Refer to Section 5 for instructions on rebuilding your gearbox.

Team Associated Building Tip!

Use our Silicone Diff Fluid when rebuilding the front or rear gearbox. The Fluid is sold in 10K, 30K, 60K, 100K and 300K weights. It is also sold as a Diff Fluid Set which contains one each of the above!

- 2390 - Diff Fluid, 10K
- 2391 - Diff Fluid, 30K
- 2392 - Diff Fluid, 60K
- 2393 - Diff Fluid, 100K
- 2394 - Diff Fluid, 300K
- 2395 - Diff Fluid Set





Section 3:

Removing the Transmission

Follow these steps to remove the transmission from the truck.

Required Tools:

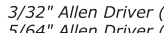
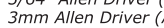
-  Phillips Screwdriver (AE #1553)
-  Needlenose Pliers
-  3/32" Allen Driver (AE #1546)
-  5/64" Allen Driver (AE #1545)
-  3mm Allen Driver (AE #1548)

1



Remove Line A.



Remove Line B.



Attach line B here.

2

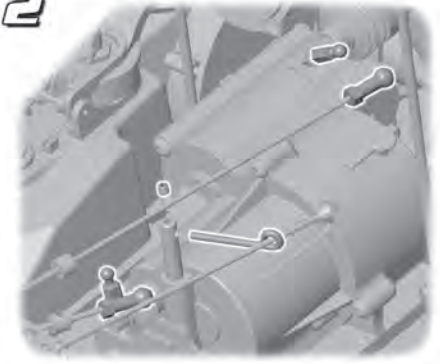

Section 3:

COMPLETE!

Refer to Section 6 for instructions on rebuilding your transmission.

Maintenance Tips

After running, allow your vehicle to cool for approximately 15 minutes before performing any maintenance. This will prevent burns from hot engine and rotating parts.

Using high quality tools (like Team Associated's Allen Driver Set (#1541), Nut Driver Set (#1561) and Screwdriver Set (#1557) will help prevent fasteners from stripping out during maintenance.

A clean air filter is important to engine performance. When the foam air filter element becomes dry, clean and oil it using Team Associated PreFilter Oil #7710 (see Monster GT User Guide, page 3, for complete instructions).

Section 4:

Removing the Engine

Follow these steps to remove the engine from the truck.

Required Tools:



Needlenose Pliers

1



Detach line A.



Detach line B.



Attach line B here.

2

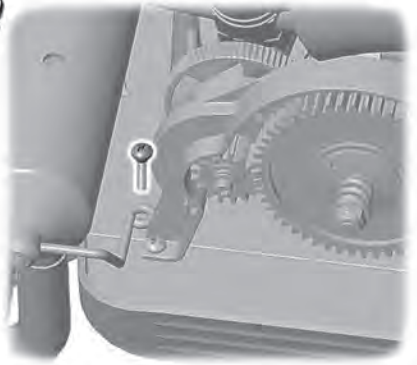

3

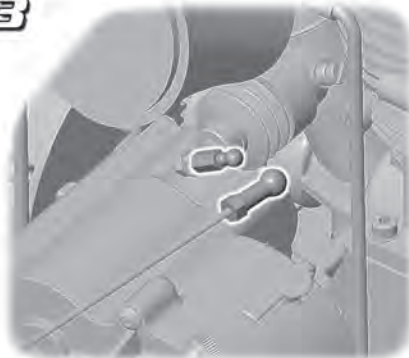

4

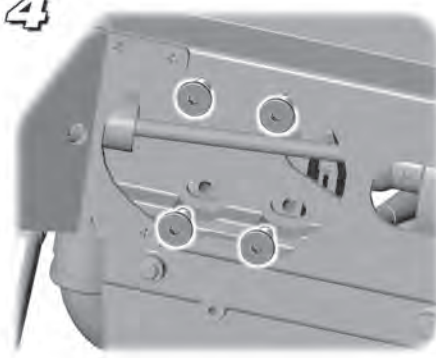

5

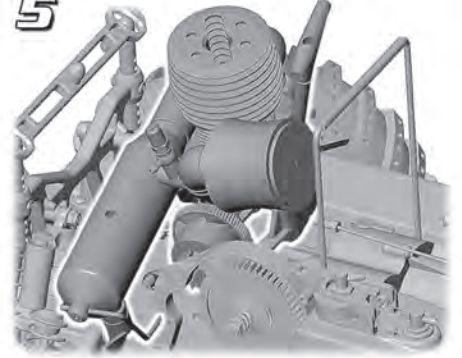

Section 4:

COMPLETE!

Refer to Section 7 for instructions on rebuilding your clutch.

Team Associated Building Tools!

Our Allen Wrench and Screwdrivers sets have been specially made with the racer in mind! Each tip is crafted from hardened steel and ground to specific dimensions. All wrenches and screwdrivers have replaceable tips and color coded handles for ease of use.

FT Hex Driver Set - #1541
FT Screwdriver Set - #1551
FT Exhaust Spring Hook - #6987

Tools also sold separately. See our Catalog for more informati



Section 5:

Rebuilding the Gearbox

Follow these steps to rebuild your front or rear gearbox.

Required Tools:

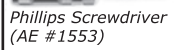

Needlenose Pliers

1



2

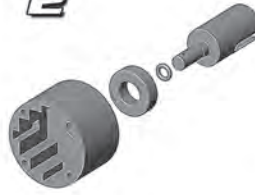

3



4



5



6



7



8

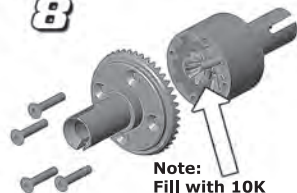

Note:
Fill with 10K weight Diff Lube

9



10



11

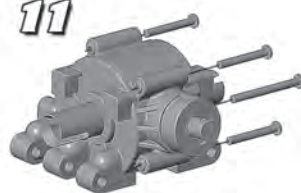

12

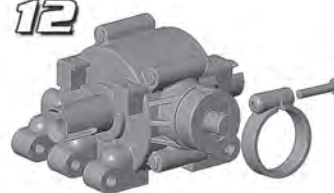

Section 5:

COMPLETE!

Your gearbox is now ready to be installed into your Monster GT.

Section 6:

Rebuilding the Transmission

Follow these steps to rebuild your trucks transmission.

Required Tools:

Phillips Screwdriver (AE #1553)

5/64" Allen Driver (AE #1545)

Assembly 1: Forward/Reverse Main Shaft

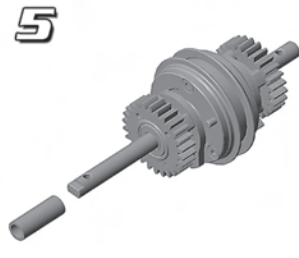
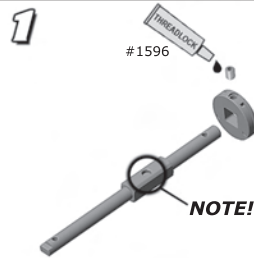

Set Assembly 1 aside and continue to Assembly 2.

Assembly 2: Two Speed Shaft

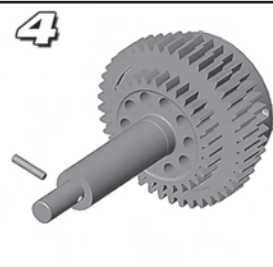
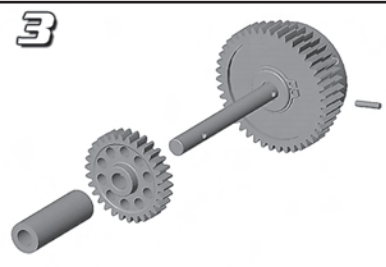
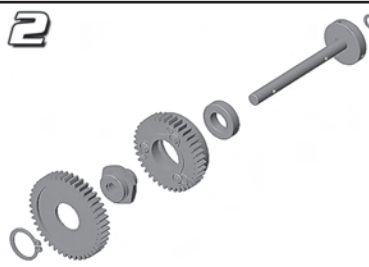
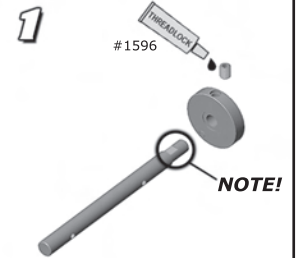

Set Assembly 2 aside and continue to Assembly 3.

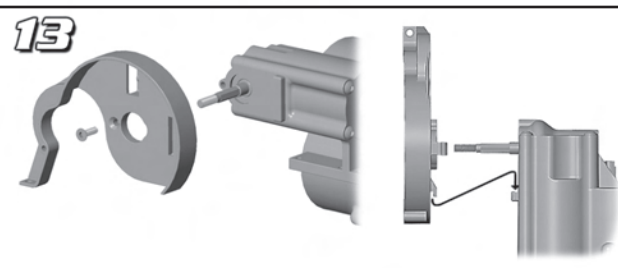
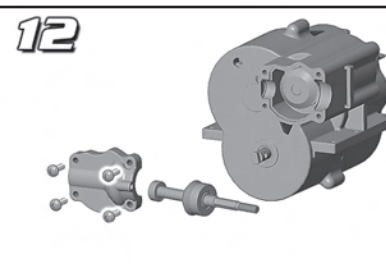
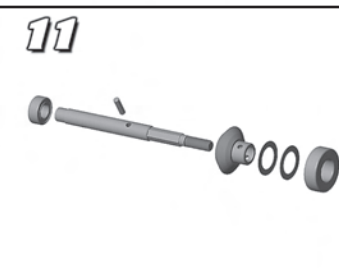
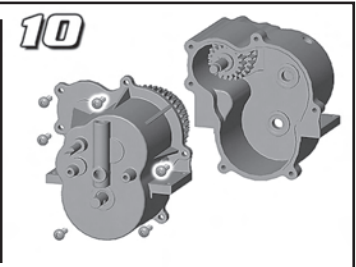
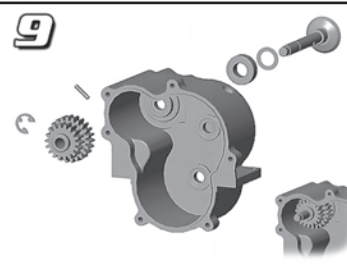
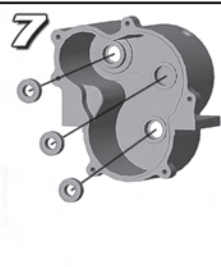
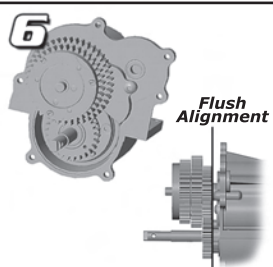
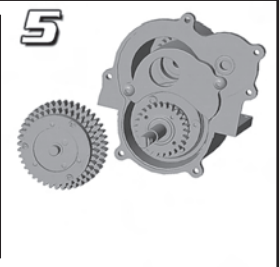
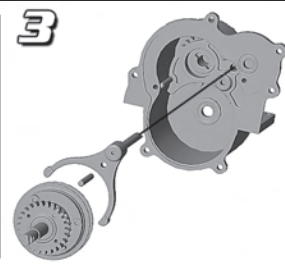
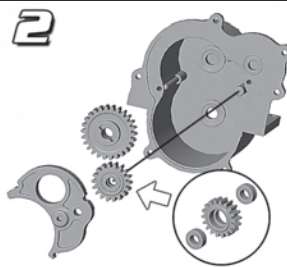
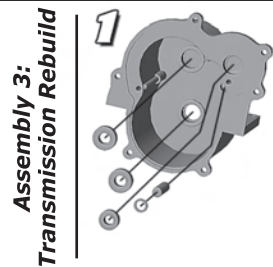

Have a Question?

If you have any questions or concerns, please call Team Associated's Customer Support Line at 714.850.9342. We will be happy to help you with any questions or problems you might have!

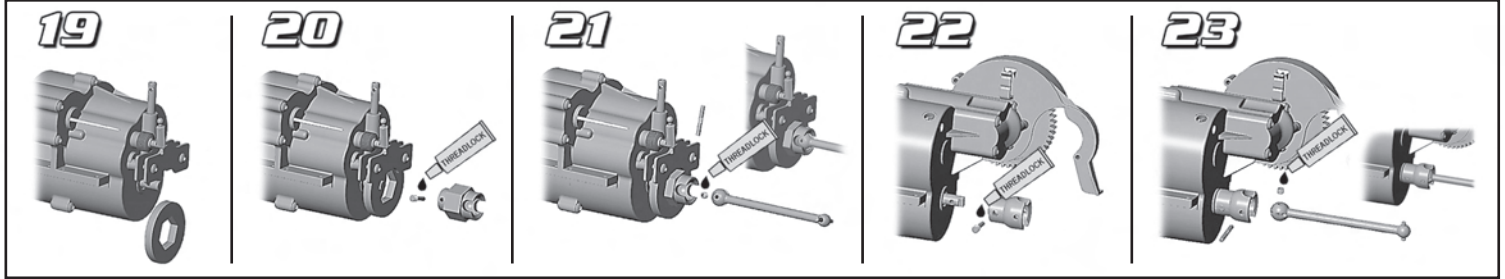
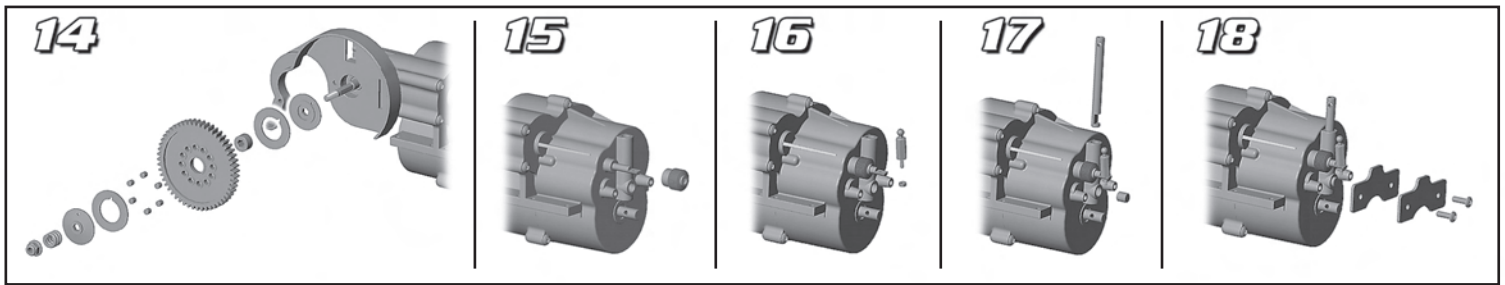

Section 6:

COMPLETE!

Your transmission is now ready to be installed in to your Monster GT.

Team Associated Optional Gears
 Improve acceleration or top speed with our optional gearing.

Clutch Bells	Spur Gears
14T - #25370	46T - #25379
15T - #25155	49T - #25378
16T - #25372 (kit)	52T - #25038 (kit)
17T - #25373	
18T - #25374	

Larger Clutch Bell/
Smaller Spur Gear = Higher Top Speed

Smaller Clutch Bell/
Larger Spur Gear = Better Acceleration

Section 7:

Rebuilding the Clutch
 Follow these steps to rebuild your trucks clutch.

Required Tools:
 5/64" Allen Driver (AE #1545)
 Needlenose Pliers

Section 7:

COMPLETE!

Your engine is now ready to be installed into your Monster GT.

Section 8:

Rebuilding the Shocks
 Follow these steps to rebuild your trucks shocks.

Required Tools:
 Needlenose Pliers
 Shock Oil (AE #5423)

Want updates on the Monster GT?

Visit our web site at www.teamassociated.com (or www.rc10.com) for all of the latest information on the Monster GT including updates, Factory Team parts, tips, tricks and setup information. You can also view our entire line of vehicles online!



Section 8:

COMPLETE!

Your shocks are now ready to be installed on to your Monster GT.

Shock Tuning Tip

Adding or removing pre-load clips will change the ride height of your truck. Add clips to raise the truck. This will help the truck climb over large objects and help prevent the truck from bottoming out on landings. Removing clips will lower the truck and its center of gravity and reduce body roll.



Team Associated Silicone Shock Oil

Available from Team Associated is the 100% Pure Silicone Shock Oil.

- 5420 - Silicone Shock Oil, 10wt
- 5421 - Silicone Shock Oil, 20wt
- 5422 - Silicone Shock Oil, 30wt
- 5423 - Silicone Shock Oil, 40wt
- 5425 - Silicone Shock Oil, 80wt
- 5427 - Silicone Shock Oil, 15wt
- 5428 - Silicone Shock Oil, 25wt
- 5429 - Silicone Shock Oil, 35wt
- 5435 - Silicone Shock Oil, 50wt
- 5436 - Silicone Shock Oil, 60wt
- 5437 - Silicone Shock Oil, 70wt



Team Associated Monster GT Spring Set

Also available is the Monster GT Spring Set. Use the chart below to find the spring best suited to your terrain.



AE Part #	Spring Color	Spring Rate	Relative Stiffness
25062	Blue (Std)	4.40 lb./in	Softest
25063	Gold	5.10 lb./in	
25064	Red	5.95 lb./in	↓
25065	Copper	6.90 lb./in	Stiffest

Section 9:

4-Cell AA to 5-Cell Rechargeable Receiver Pack

Follow these steps to replace your 4-Cell AA Receiver Pack with a 5-Cell Rechargeable Hump Receiver Pack.

Required Tools:

-  Reedy 5-Cell Rechargeable Receiver Hump Pack (AE #615)

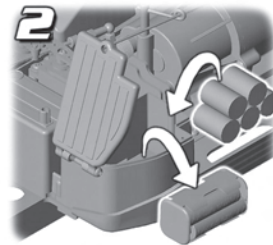
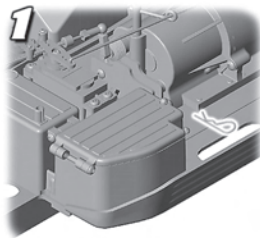

5-Cell Receiver Pack does not come charged.

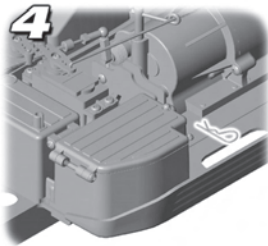
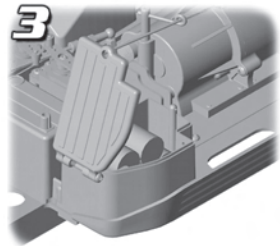

Section 9:

COMPLETE!

Your Monster GT is now ready to run!

Receiver Pack Tip

A 5-Cell Pack has two benefits:

- 1) It's rechargeable (no more AA's), and
- 2) 5- Cell packs provide more power to the trucks onboard electronics.

Your servos will react faster and have more power, and you will be able to drive longer between battery changes.

Notes:



Monster GT Parts List

5/05

First use the exploded drawings on the following pages to located the part you need. Then, look up it's part number in the left column in numerical order.

Can't find the part you're looking for? See later sections for parts not in the exploded drawings.

Prices subject to change without notice. Typographic errors or other product pricing/description errors will not be honored.

Prices subject to availability.

Screw Abbreviations:

SHH - Socket Head Hex BHPT - Button Head Phillips Tapping
 FHP - Flat Head Phillips BHP - Button Head Phillips
 FHH - Flat Head Hex BHH - Button Head Hex

Part #	Description	Qty	Price
6299	1/8" E-Clip	12	\$1.00
6332	Body Clips	6	.75
6338	Antenna Kit, tube & cap	1	2.00
7725	Fuel Tubing, 3 feet	1	4.00
25010	MGT Complete Bearing Set, 34 total	Set	109.99
25012	Two-Speed One-way Hub	1	21.99
25011	Two-Speed Drive Pinion (metal)	1	11.99
25013	Two-Speed Pinions & Spurs	Set	16.99
25014	Two-Speed Support Pins & Rings	1	8.99
25015	Two-Speed Clutch Hub Assembly	1	15.99
25016	Two-Speed Shaft	1	4.99
25018	Two-Speed Pinion & Shaft Upgrade (metal)	Set	14.99
25019	Main Gearbox Shims & Clips	Set	3.99
25020	Main Gearbox Roll Pins	4	3.99
25021	Main Gearbox Transmission Pin Set	Set	5.99
25022	Forward & Reverse Drive Gears	Set	8.99
25023	Drive Pinion Shaft	1	4.99
25024	Forward & Reverse Shifting Gears	Set	15.99
25025	Forward/Reverse Clutch Housing	1	16.99
25026	Forward/Reverse Clutch Hub Assembly	1	22.99
25027	Forward/Reverse Main Shaft	1	11.99
25028	Reverse Idler Gear & Shaft	Set	4.99
25030	Shifting Lever Fork	1	6.99
25031	Reverse Gear/Shift Fork Mount	1	4.50
25032	Main Bevel Gear Set	Set	25.99
25033	Drive Pinion Set	Set	5.99
25035	Slipper Shaft	1	6.50
25036	Inner & Outer Slipper Hub	2	11.99
25037	Slipper Rings	2	5.50
25041	MGT SE Main Transmission Assembly	1	149.99
25042	Slipper Friction Pegs	6	5.50
25043	Slipper Hardware	1	2.99
25044	Main Gearbox Case Set	Set	13.99
25045	Main Gearbox Screw Set	21	3.50
25046	MGT Transmission, complete, assembled	1	149.99
25047	Brake Cam & Hardware	1	4.99
25048	Brake Shoes & Screws	2	6.99
25049	Brake Disc	1	13.50
25050	Front or Rear Drive CVA	1	10.99
25051	Front or Rear Drive Input Cup	1	5.99
25053	Front Drive/Disc Brake Hub	1	6.99
25054	Rear Drive Output Cup	1	6.50
25055	Front or Rear Drive CVA Hardware	Set	5.99
25056	Drive Cup Set Screws	4	4.99
25058	Assembled Shocks	8	75.99
25059	Assembled Shocks	Pr.	19.99
25061	Shock Rebuild & Shafts	2	6.99
25069	Shock Eyelets & Accessories	4	7.99
25070	Shock Mounting Hardware	4	5.99
25074	MGT Fuel Tank Accessories	1	4.99
25075	MGT Fuel Tank (150 cc)	1	21.99
25076	Fuel Primer Pump	1	5.99
25077	MGT Air Cleaner	1	7.99
25078	Air Cleaner Foam	Set	9.99
25080	Differential Pinion Gear & Shaft	1	13.99

25081	Assembled Differential	1	\$49.99
25082	Front/Rear Transmission Case w/Screws	Set	8.99
25087	Muffler Mounting Wire	1	1.99
25090	MGT Muffler Assembly	1	19.99
25092	Exhaust Manifold	1	10.99
25093	Manifold O-Ring, Coupler, & Muffler Outlet	Set	3.99
25094	Exhaust Manifold Spring	1	3.50
25100	MGT Chassis	1	69.99
25102	Chassis Guards & End Covers	Set	11.50
25103	Roll Bar	1	4.99
25104	Roll Bar Mounts	2	8.99
25105	Front & Rear Upper Arm Mounts	Set	13.50
25106	Front & Rear Transmission Chassis Mounts	4	5.50
25107	Upper Suspension Arms	Pr.	7.50
25109	Lower Suspension Arms	Pr.	7.50
25110	Upper & Lower Arm Hinge Pins	Set	9.99
25112	Steering Block/Hub Carrier	Set	6.50
25113	Pivot Balls	4	8.99
25114	Universal Drive Axle Assembly	1	23.99
25115	Universal Axle Rebuild Kit	2	6.50
25116	Axle Bearing Spacers	4	2.99
25117	Axle Pins	4	1.99
25118	Wheel Hex Drives	4	4.99
25120	Front Steering Turnbuckles	2	5.50
25121	Front & Rear Turnbuckle Eyelet & Balls	Set	11.50
25122	Rear Toe Turnbuckles	2	5.50
25125	Bellcrank Plastic Parts	Set	4.99
25126	Bellcrank Posts & Bushings	Set	4.99
25127	Bellcrank Hardware	Set	5.99
25128	Front Skid Plate	1	9.50
25129	Front Bumper & Brace	Set	5.99
25131	Front & Rear Bumper Extensions	4	6.99
25133	Rear Bumper & Brace	Set	5.50
25134	Rear Skid Plate	1	9.50
25135	Front Shock Tower	1	5.50
25136	Rear Shock Tower	1	5.50
25137	Pivoting Body Mounts & Posts	4	6.99
25139	Rear Clip & Flag Mount	1	7.99
25140	Rear AE Flag & Post	1	3.99
25145	Engine Mount	1	15.99
25146	Flywheel Collet	1	3.99
25147	Flywheel, 3 Shoe	1	9.50
25148	Clutch Nut SG	1	4.99
25149	Clutch Shoes	3	13.99
25150	Clutch Springs	3	2.99
25152	Clutch Hardware	4	3.99
25160	Radio Tray	1	12.50
25162	Servo Saver, XT/Futaba	1	8.50
25163	Servo Horns	2	3.50
25164	Forward/Reverse Shifting Linkage	Set	7.50
25165	Throttle/Brake Linkage	Set	6.99
25166	Servo Saver, Hitec	1	9.99
25167	Servo Saver, JR/Airtronics	1	9.99
25180	M3X8mm BHPS	20	1.99
25181	M3x10mm BHPS	20	1.99
25182	M3x12mm BHPS	20	1.99
25183	M3x14mm BHPS	20	1.99
25184	M3x16mm BHPS	20	1.99
25185	M3x20mm BHPS	20	1.99
25187	M3x14mm BHHS	20	7.50
25188	M3x20mm BHHS	20	6.99
25189	M3x22mm BHHS	20	8.50
25190	M3x14mm SHHS	20	4.99
25191	M3x18mm SHHS	20	4.99
25192	M3x20mm SHHS	20	5.50
25193	M3.5x10mm SHHS	20	4.99
25194	Engine Mount Screws	20	4.99
25195	M2x6mm FHPS	20	2.99
25196	M2x8mm FHPS	20	2.99
25198	M2.6x16mm FHPS	20	2.99
25199	M3x8mm FHPS	20	2.99
25200	M3x10mm FHPS	20	2.99
25201	M3x8mm FHHS	20	7.50
25202	M3x10mm FHHS	20	7.50
25203	M3x12mm FHHS	20	7.50
25204	M3x16mm FHHS	20	7.50
25205	Body Post Mounting Screws	20	7.50
25207	M3x10mm BHPTS	20	2.99
25208	M3x23mm BHPS	20	2.99
25209	M3x32mm BHPS	20	2.99
25210	M3x30mm BHPS	20	2.99
25211	M3x10mm BHHS	20	7.50
25214	M2 Nut	20	1.99
25215	M3 Locknut	20	2.99
25216	M3 Locknut w/Flange	20	3.99
25217	M4 Locknut w/Flange	20	4.50
25218	M5 Locknut	20	2.99
25220	Washer 5x12x1	20	1.99
25223	M4x3mm Set Screws	20	4.99
25224	M4x4mm Set Screws	20	4.99
25225	M3x3mm Set Screws	20	4.50

25226	M4x5mm Set Screws	20	\$4.50
25227	M4x8mm Set Screws	20	4.99
25230	2mm E-Clips	20	1.99
25231	2.5mm E-Clips	20	2.50
25232	Lock Washer	20	1.99
25235	10x19x5 Ball Bearings	2	6.99
25236	8x16x5 Ball Bearings	2	5.99
25237	5x10x4 Ball Bearings	2	4.99
25238	6x12x4 Ball Bearings	2	5.99
25239	5x11x4 Ball Bearings	2	4.99
25240	M3x22mm Shoulder Screw	20	3.99
25242	Washer 3x8x1	20	1.99
25243	E-Clips, 5mm	20	1.99
25244	C-Clips, 15mm	20	3.99
25245	M2.6x12mm FHPS	20	1.99
25246	M2.6x8mm BHPTS	20	1.99
25247	Radio Tray Clips	20	3.99
25261	Monster GT Hex Drive Starter Shaft	1	5.99
25426	MGT 4.60 Exhaust Manifold	1	11.99
25427	MGT 4.60 Muffler	1	19.99
25428	MGT 4.60 Muffler Wire Mount	1	1.99

AE .21 Engine Parts

25300	AE .21 Motor, Complete	1	\$249.99
25305	AE .21 Crankshaft	1	51.99
25306	AE .21 Crankcase	1	52.99
25307	AE .21 Connecting Rod	1	18.99
25308	AE .21 Wrist Pin Assembly	1	4.99
25309	AE .21 Piston Pin Circlip	Set	2.99
25310	AE .21 Cylinder & Piston	Set	74.99
25311	AE .21 Cylinder Head	1	44.99
25314	AE .21 Gasket Set	Set	3.99
25315	AE .21 Carburetor Retaining Bolt	Set	5.99
25316	AE .21 Carburetor Assembly	1	59.99
25317	AE .21 Carburetor Body	1	24.99
25318	AE .21 Needle Valve Assembly	Set	23.99
25319	AE .21 Needle Valve Only	1	9.99
25320	AE .21 Carburetor Slide Valve Assembly	Set	28.99
25321	AE .21 Mixture Metering Screw Set	Set	9.99
25322	AE .21 O-Ring Set	Set	4.99
25323	AE .21 Bolt & Fuel Inlet	Set	4.99
25324	AE .21 Carburetor Recovery Spring	1	2.50
25325	AE .21 Crankcase Ball Bearing, Front	1	10.99
25326	AE .21 Crankcase Ball Bearing, Rear	1	22.99
25327	AE .21 Motor Screw Set	Set	6.99
25330	AE .21 One Way Clutch Set (Pull start)	Set	17.99
25331	AE .21 Pull Start Handle Set	Set	2.99
25333	AE .21 Pull Start Starting Axle	1	9.99
25335	AE .21 Pull Start Starting Spring	1	9.99
25337	AE .21 Motor Backplate	1	17.99
25339	AE .21 Motor Starting Wheel Wire	1	2.99
25341	AE .21 Motor Starting Wheel	1	4.99
25343	AE .21 Pull Start Cover	1	13.99
25345	AE .21 Pull Start Assembly	1	54.99
25347	AE .21 Motor Backplate w/screws	Set	25.99
25349	AE .21 Pull Start	1	33.99
25353	AE .21 Starter Coupling	1	7.99
25329	AE .21 One Way Clutch Set (Crankshaft clutch)	Set	19.99

AE 4.60 Engine Parts

25077	AE 4.60 Air Cleaner Set	Set	\$7.99
25309	AE 4.60 Circlip	Set	2.99
25318	AE 4.60 Needle Valve Assembly	1	23.99
25319	AE 4.60 Needle Valve Only	1	9.99
25320	AE 4.60 Carburetor Slide Valve Assembly	1	28.99
25321	AE 4.60 Mixture Metering Screw Set	Set	9.99
25322	AE 4.60 O-Ring Set	Set	4.99
25323	AE 4.60 Bolt and Fuel Inlet	1	4.99
25324	AE 4.60 Recover Spring	1	2.50
25325	AE 4.60 Ball Bearing	1	10.99
25326	AE 4.60 Ball Bearing	1	22.99
25327	AE 4.60 Screw Set	Set	6.99
25329	AE 4.60 Oneway Clutch Set	Set	19.99
25330	AE 4.60 Oneway Clutch Set	Set	17.99
25331	AE 4.60 Handle Set	Set	2.99
25333	AE 4.60 Starting Axle	1	9.99
25354	Complete AE 4.60 Engine	1	249.99
25335	AE 4.60 Starting Wheel	1	9.99
25339	AE 4.60 Starting Wheel Wire	1	2.99
25341	AE 4.60 Starting Wheel	1	4.99
25343	AE 4.60 Starting Wheel Cover	1	13.99
25349	AE 4.60 Starting Cover Set	Set	33.99
25353	AE 4.60 Starting Coupler	1	7.99
25355	AE 4.60 Crankshaft	1	51.99
25356	AE 4.60 Crankcase	1	52.99
25357	AE 4.60 Connecting Rod	1	15.99
25358	AE 4.60 Wrist Pin Assembly	1	4.99
25359	AE 4.60 Cylinder & Piston	Set	74.99

25360	AE 4.60 Cylinder Head	1	\$44.99
25361	AE 4.60 Gasket Set	Set	3.99
25362	AE 4.60 Gasket (0.1mm)	1	3.99
25363	AE 4.60 Carburetor Retaining Bolt	1	5.99
25364	AE 4.60 Carburetor Assembly	1	59.99
25365	AE 4.60 Backplate	1	17.99
25366	AE 4.60 Starting Set	Set	54.99
25367	AE 4.60 Backplate Set	Set	25.99
25368	AE 4.60 Exhaust Coupler (3pc)	Set	3.99
25432	AE 4.60 Carburetor Body	1	24.99



Team Options

1738	FT Glow Igniter - Blue 110V	1	\$29.99
1749	Nitro Fuel Bottle 400cc	1	7.99
2390	Silicone Diff Fluid, 10K Weight	.75oz	4.95
2391	Silicone Diff Fluid, 30K Weight	.75oz	4.95
2392	Silicone Diff Fluid, 60K Weight	.75oz	4.95
2393	Silicone Diff Fluid, 100K Weight	.75oz	6.95
2394	Silicone Diff Fluid, 300K Weight	.75oz	6.95
2395	Silicone Diff Fluid Set (1 each of the above weights)	Set	25.95
25089	Factory Team MGT Muffler, blue	1	28.99
25381	Steering Turnbuckle - Titanium	1	10.99
25382	Rear Turnbuckle - Titanium	1	10.99
25383	Monster GT Turnbuckle Set - Titanium	Set	44.99
25384	Monster GT Turnbuckle Wrench	1	2.99
25385	Factory Blue Monster GT Chassis - Machined	1	109.99
25387	Factory Blue Monster GT Cylinder Head - Machined	1	49.99
25390	Factory Blue 5mm Locknut	10	7.99
25391	Factory Blue 4mm Locknut	10	7.99
25392	Factory Blue 3mm Locknut	10	7.99
25395	Monster GT Optional Steering Kit	1	74.99
25396	Monster GT Optional Steering Rack/Arm Only	Set	54.99
25397	Monster GT Optional Steering Servo Saver Hub/Spring	Set	5.99
25398	Monster GT Optional Steering Hardware	1	6.99
25400	Factory Blue Monster GT Wheel Hex Drives	4	16.99
25403	Factory Blue Monster GT Shock Bodies	4	34.99
25405	Monster GT Side Mount Exhaust Manifold	1	18.99
25407	Monster GT Side Exhaust Wire Mount	1	1.99
25410	Monster GT "Robo-Disc" Vented Disc Brake	1	15.99
25415	Monster GT Forward Only Kit	1	15.99
25429	4.60 Dual Chamber Side Muffler	1	29.99
25430	4.60 Dual Chamber Side Muffler Wire Mount	1	1.99
25431	4.60 Dual Chamber Side Muffler Kit	Set	49.99
25433	4.60 Side Exhaust Muffler	1	18.99

Bodies & Wings

Contact Pro-Line for other bodies for the Monster GT

25175	MGT Preprinted Body - Flag Design	1	\$49.99
25177	MGT Preprinted Body - Red Design	1	49.99
25178	MGT Preprinted Body - Blue Design	1	49.99
25179	MGT Body - Clear, with sticker sheet	1	29.99

Monster GT

20501	Monster GT RTR 4.60 SE	1	\$839.99
-------	------------------------	---	----------

Oils, Grease & Lubes

1105	Green Slime Shock Lube	4cc	\$2.50
5420	Silicone Shock Oil, 10 wt. 2 ounce bottle	1	3.50
5421	Silicone Shock Oil, 20 wt. 2 ounce bottle	1	3.50
5422	Silicone Shock Oil, 30 wt. 2 ounce bottle	1	3.50
5423	Silicone Shock Oil, 40 wt. 2 ounce bottle	1	3.50
5425	Silicone Shock Oil, 80 wt. 2 ounce bottle	1	3.50
5427	Silicone Shock Oil, 15 wt. 2 ounce bottle	1	3.50
5428	Silicone Shock Oil, 25 wt. 2 ounce bottle	1	3.50
5429	Silicone Shock Oil, 35 wt. 2 ounce bottle	1	3.50
5435	Silicone Shock Oil, 50 wt. 2 ounce bottle	1	3.50
5436	Silicone Shock Oil, 60 wt. 2 ounce bottle	1	3.50
5437	Silicone Shock Oil, 70 wt. 2 ounce bottle	1	3.50
6588	Black Grease	4cc	2.50
6591	Stealth Diff Lube	4cc	2.50

Springs

25062	Blue/Soft Shock Springs - 4.40lbs	4	\$6.99
25063	Gold/Medium Shock Springs - 5.10lbs	4	6.99
25064	Red/Firm Shock Springs - 5.95lbs	4	6.99
25065	Copper/Extra Firm Shock Springs - 6.90lbs	4	6.99

MGT Gears & Clutch Bells

25038	Spur Gear 52T	1	\$3.99
25155	Clutch Bell, 15T	1	13.99
25370	Clutch Bell, 14T	1	14.99
25372	Clutch Bell, 16T	1	14.99
25373	Clutch Bell, 17T	1	14.99
25374	Clutch Bell, 18T	1	14.99
25378	Spur Gear 49T	1	4.99
25379	Spur Gear 46T	1	4.99

Wheels & Tires

25170	MGT Tires & Foam Inserts	2	\$29.99
25171	MGT Wheels	2	14.99

Radio Gear

29102	XP2/XP3 Transmitter Antenna	1	\$8.99
29107	Servo Gear Sets - Metal	Set	8.99
29108	Crystal Set CH1 - Brown	Set	11.99
29109	Crystal Set CH2 - Red	Set	11.99
29110	Crystal Set CH3 - Orange	Set	11.99
29111	Crystal Set CH4 - Yellow	Set	11.99
29112	Crystal Set CH5 - Green	Set	11.99
29113	Crystal Set CH6 - Blue	Set	11.99
29115	Switch Harness for 29123	1	9.99
29117	4 Cell Battery Holder for 29123	1	4.99
29118	Servo Accessory Package	1	5.99
29121	XP3 Transmitter Only w/o Crystal	1	59.50
29123	Receiver 4CH AM27 TR403A	1	49.50
29124	Servo S1903	1	15.99
29126	Servo S2008MG	1	74.99
29150	TX/RX Charger	1	16.99

Tools

1541	Factory Team Hex Driver Set. Allen drivers below in one package, with tips.	Set	\$59.95
1542	.050" Allen Driver, silver anodized handle	1	10.50
1543	1/16" Allen Driver, black anodized handle	1	10.50
1544	1.5mm Allen Driver, purple anodized handle	1	10.50
1545	5/64" Allen Driver, blue anodized handle	1	10.50
1546	3/32" Allen Driver, gold anodized handle	1	10.50
1547	2.5mm Allen Driver, green anodized handle	1	10.50
1548	3mm Allen Driver, red anodized handle	1	10.50
1551	FT Screwdriver Set, 1 Phillips & 1 slotted	Set	19.99
1552	FT Slotted Screwdriver, gray anodized handle	1	10.50
1553	FT Phillips Screwdriver, gray anodized handle	1	10.50
1572	.050" Replacement Tip, precision ground	1	5.50
1573	1/16" Replacement Tip, precision ground	1	5.50
1574	1.5mm Replacement Tip, precision ground	1	5.50
1575	5/64" Replacement Tip, precision ground	1	5.50
1576	3/32" Replacement Tip, precision ground	1	5.50
1577	2.5mm Replacement Tip, precision ground	1	5.50
1578	3mm Replacement Tip, precision ground	1	5.50
1593	Factory Team Body Reamer Tip	1	9.95
1594	Factory Team Body Mounting Hole Reamer	1	22.00
1737	Factory Team Body Scissors	1	5.99
6956	Associated Molded Tool Set	Set	4.50
6985	FT Straight Screwdriver Replacement Tip	1	7.50
6986	FT Phillips Screwdriver Replacement Tip	1	7.50
25260	Monster GT Nut Wrench	1	3.99
25261	Monster GT Hex Drive Starter Shaft	1	5.99

Decals & Apparel

SP53*	AE Sweatshirt, long sleeve, blue. Specify Med., L, XL, XXL, XXXL	1	\$42.99
SP409*	AE Logo Cap. Dark blue with embroidered AE logo in silver thread on the front and back.	1	19.99
717	Reedy Modified Sticker Sheet. 8.5" x 5.5" black & white	1	2.50
3817	Associated Bumper Stickers. 1 large, 1 small. Red, white & blue.	2	4.00
3820	"AE" logo decal sheet	1	2.00
3824	Factory Team "Driver" Decal, 10" x 4.25"	1	2.00
3825	Factory Team Logo Decal Sheet	1	2.00
3830	Associated Team Decals, white on black	1	2.00
3834	AE Blue Embossed Decal	2	3.00
6196	Team Associated & Misc. Sponsor Decal, 5 colors	1	2.00
25425	Monster GT Decal Sheet	1	2.50