

PROLITE 4x4

#7052 Pro Lite 4x4 RTR

READY-TO-RUN

BRUSHLESS POWERED / ELECTRIC SHORT COURSE TRUCK



Official R/C Car of the



1:10 Scale Electric 4WD Short Course Truck Manual & Catalog

QUALIFIER

S E R I E S

TEAM ASSOCIATED

:: Introduction

Thank you for purchasing this Team Associated Qualifier Series product. This manual contains instructions and tips for maintaining your new ProLite 4x4 RTR. Please take a moment to read through it and familiarize yourself with these steps as they will help you to understand each component's function and show you some tips for getting the most out of your ProLite 4x4 RTR. We are continually changing and improving our designs; therefore, actual parts may appear slightly different than the illustrations.

For more information, scan the QR code to the right for videos and tutorials on the ProLite 4x4 RTR!



http://www.teamassociated.com/cars_and_trucks/ProLite_4x4/

:: ProLite 4x4 Platform Features

- Fully assembled, shaft drive 4wd short course truck with gear differentials and torque clutch
- XP SC900-BL water-resistant speed control with Deans® Ultra Plug® connector
- Reedy WolfPack 7-cell NiMH Battery w/Deans® Ultra Plug® Connector
- Powerful Reedy 550-SL 3500KV Brushless motor
- XP 2.4Ghz Radio system with XP metal gear steering servo
- Composite modular chassis accepts NiMH or LiPo type batteries
- Enclosed water-resistant receiver box
- KMC replica hex drive wheels with aggressive short course racing tires
- Fluid filled adjustable shock absorbers
- Adjustable steel turnbuckles
- All steel drive axles front and rear
- Factory finished short course race body with decals installed
- All metric hardware and ball bearings throughout
- Rugged front and rear bumpers

:: Additional Items Needed

Your ProLite 4x4 RTR requires the following items to complete your kit:

- Transmitter batteries (x6) (#302, 303 recommended)
- Battery charger (peak detection charger recommended) (AE #604) -OR- Wall charger (#29154)
- Needle nose pliers • Hobby knife • Reamer/hole punch
- Ride Height Gauge (#1449 recommended)

:: Other Helpful Items

- Silicone Shock Fluid / Differential Fluid (Refer to catalog for complete listings)
- Body Scissors (AE Part # 1737)
- FT Hex Wrenches (AE Part # 1541, 1655)
- FT Nut Drivers (AE Part # 1561, 1663-1668)
- FT Turnbuckle Wrench (AE Part #1112)
- Green Slime shock lube (AE Part # 1105)
- FT Threadlock (AE Part # 1596)
- Multi Tool (AE Part # 7494)
- Calipers or a Precision Ruler
- Soldering Iron
- Wire cutters

Associated Electrics, Inc.
26021 Commercentre Dr.
Lake Forest, CA 92630



Customer Service
Tel: 949.544.7500
Fax: 949.544.7501

:: Table of Contents

1.....Cover	13-14.....Front Diff Access
2.....Introduction	14.....Diff Maintenance
3.....Table of Contents	14-15.....Shock Maintenance
4.....Blueprint of a ProLite 4x4	16.....Motor Manual
5-7.....Quick Start Guide	17.....ESC Manual
8.....Radio, Speed Control Wiring	18-27.....Catalog
9.....Gear Mesh & Ride Height	28.....1:1 Hardware "Fold Out"
10.....Camber & Toe Settings / Slipper Adjustment	29.....Optional Tools / Contact Info
11-12.....Spur Gear Access / Rear Diff Access	30.....Trouble Shooting

:: Notes



This symbol indicates a special note or instruction in the manual.



There is a 1:1 hardware foldout page in the back of the manual. To check the size of a part, line up your hardware with the correct drawing until you find the exact size. Each part in the foldout has a number assigned to it for ordering replacement parts.

Associated Electrics, Inc.
26021 Commercentre Dr.
Lake Forest, CA 92630



Customer Service
Tel: 949.544.7500
Fax: 949.544.7501

:: Blueprint of a ProLite 4x4

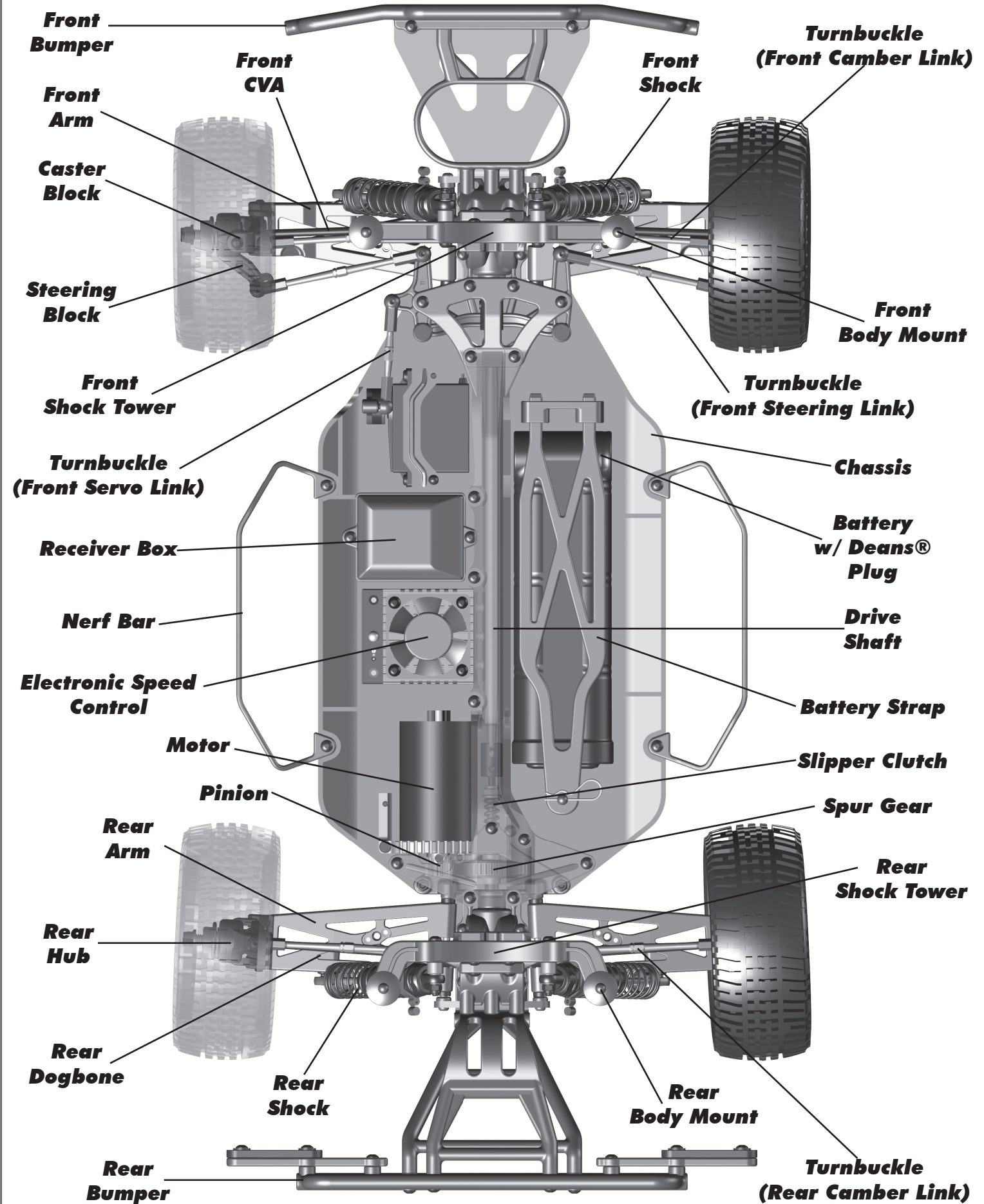

:: Quick Start Guide

Battery Charging Steps and Safety:

NiMH Wall Charger: (Part #29154 - Wall Charger AC 120V 350mAh)

NiMH Quick Charger: (Part #610 - Reedy 447-S AC/DC 4-7 Cell Peak Prediction NiMH/NiCd Charger)

Remove the battery from the vehicle before charging. Be sure to select the correct charging mode for the type of battery you are charging.

NEVER leave the battery unattended while charging!

NiMH: NiMH batteries (nickel-metal hydride) are high current rechargeable batteries. If you use a peak detection charger, make sure it is designed for NiMH batteries!



Wall Charger



Peak Detection Quick Charger

:: Quick Start Guide - (cont.)

Battery Installation:

1. Install the battery with the battery wires directed towards the rear of the vehicle.
2. Insert the tabs of the battery strap into the battery wall.
3. Slide the opposite side of the battery strap onto the battery post and secure with a body clip.

You may move the foam pad to either the front or the rear of the battery compartment to adjust the weight balance of the vehicle.



:: Quick Start Guide - (cont.)

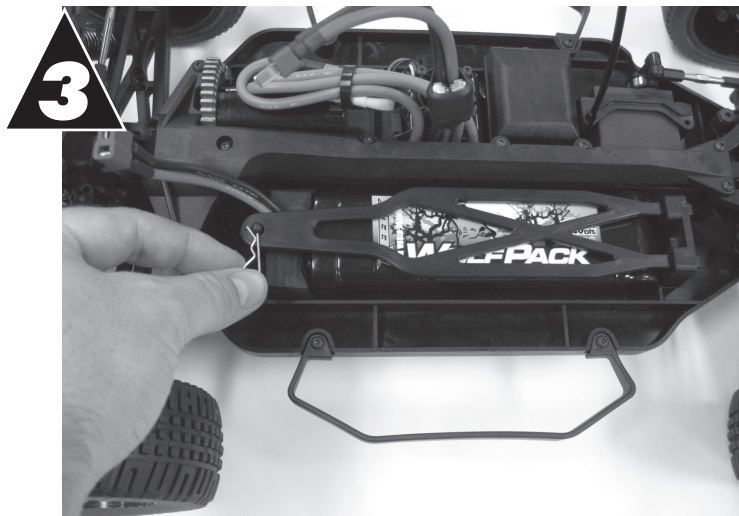
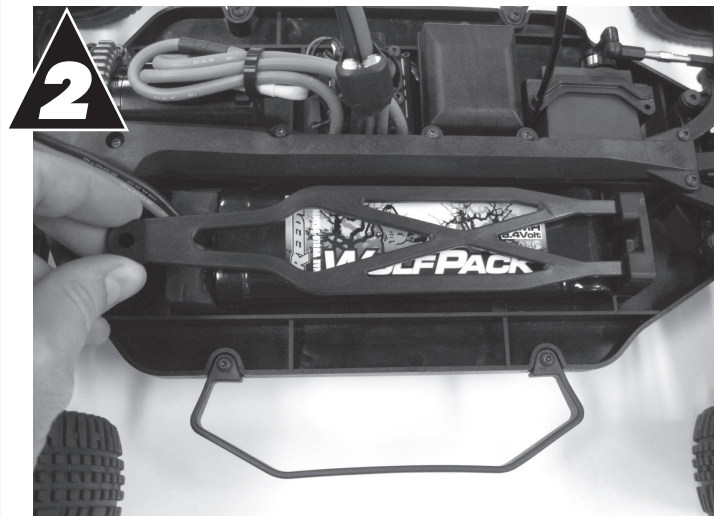

:: Quick Start Guide - (cont.)

Change the speed control to NiMH or LiPo battery modes.

- 1) Make sure both TH. ATV (LO & HI) is set on your transmitter all the way to the right or at 100% before you start.
- 2) Turn on the transmitter.
- 3) Pull trigger to full throttle and hold it.
- 4) Turn on the speed control. You will hear six beeps (bibibibibi) and see six flashing green lights.
- 5) Release trigger back to neutral. You will hear two sets of two beeps (bibi-bibi) and see four flashing green lights.
- 6) Push trigger to full brakes/reverse. You will hear two sets of two beeps (bibi-bibi) and see four flashing green lights.
- 7) Release trigger back to the neutral position. You will see a red static light.

Wait a few seconds and you will hear audio tones.

- 8) For NiMH Battery you will hear 1 tone, a pause, then 1 tone pull and release trigger to select this mode. You will hear two sets of two beeps (bibi-bibi) and see four flashing green lights.

Now the speed control is in NiMH (nickel metal mode).

If this is your desired setting, turn off your speed control and radio! If not, do not select this mode and continue to step #9.

- 9) For Lipo Battery you will hear 1 tone, a pause, then 2 tones pull and release trigger. You will hear two sets of two beeps (bibi-bibi) and see four flashing green lights.

Now the speed control is in LiPo mode (lithium polymer mode)

- 10) If this is your desired setting, turn off your speed control and radio! If you would like to change the Drag Brake, Throttle Profile, and Run Mode, see page 17 for the rest of the Speed Control setup sequence.

1



Throttle set to Neutral when turning on the radio !

:: Quick Start Guide - (cont.)

Battery Notes and Tip:

Plug the battery in as shown. Unplug battery when not in use! There are two types of batteries you can use with this vehicle. NiMH (nickel-metal hydride) and LiPo (lithium polymer).

LiPo: LiPo batteries (lithium polymer) are high current rechargeable batteries. LiPo batteries offer extended run time and peak performance over NiMH batteries. They require a peak detection charger designed specifically for LiPo batteries.

LiPo/LiFe Charger: (Part # 604 - Reedy 526-S AC/DC 2S-6S Cell LiPo/LiFe Balance Charger)

These batteries require special care and handling.

LiPo batteries are recommended for advanced users only!

ALWAYS charge a LiPo battery in LiPo mode.

CAUTION! If using a LiPo battery, you need to change the speed control settings to LiPo mode (see page 17 for instructions).

If using a 3S LiPo battery, you must use a smaller pinion gear (use part #91164 13T Pinion). This will give you the correct gear ratio for the extra power the 3S LiPo battery will deliver.

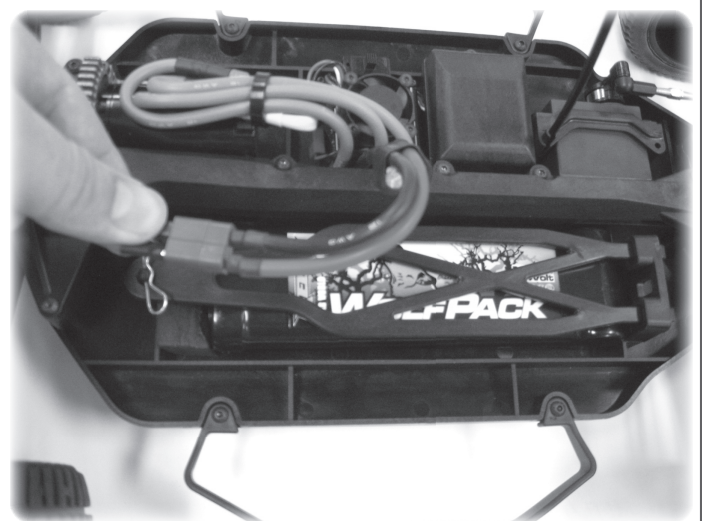

:: Quick Start Guide - (cont.)

Radio System Tuning and Controls:

RULE: Transmitter on First/Vehicle on Second, Vehicle off First/ Transmitter off Last!

- 1) Slide the battery cover in the direction shown to remove cover.
- 2) Install six (6) alkaline or rechargeable AA size batteries into the battery holder.
- 3) Slide the battery cover back into place making sure it is completely closed and secure.
- 4) Turn the power ON. If the power indicator LED fails to light, check the batteries for insufficient contact or incorrect polarity.

While pressing this part

Battery cell (x6)



On/Off Switch

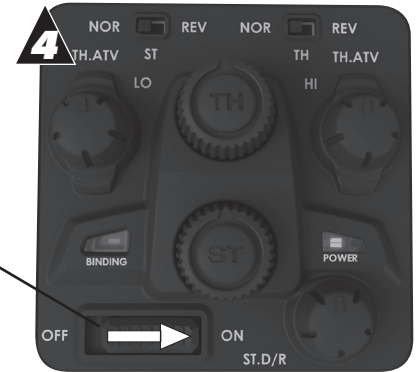

:: Quick Start Guide - (cont.)

Radio System Tuning and Controls:

DO NOT hold the trigger when turning on the radio.

If using optional battery for transmitter, be sure to plug it in correctly. Plugging in a battery backwards can cause damage.

Refer to Radio owners manual for more in-depth instructions on radio operation and functions.



Throttle set to Neutral when turning on the radio !

:: Quick Start Guide - (cont.)



Adjust steering trim so front wheels point straight.

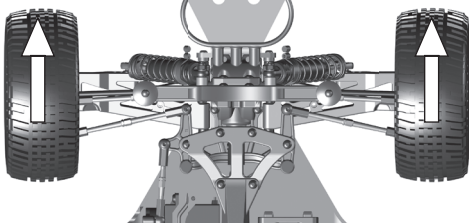

Install body and body clips.

Ready to go!

:: Wiring Diagrams

Receiver Box Gasket Maintenance:

1. Apply a small amount of "hobby grade" glue to the top edge of the receiver box in order to hold the receiver box gasket in place. Do the same for the receiver box lid. Make sure not to get glue on the side of the gaskets that will make contact with each other!

Wait until the glue has completely dried before moving on to the next step!

2. Once the receiver box gasket is installed, you can then plug your servo and speed control into your receiver. You can also run your receiver's antenna wire into the antenna tube. Once this is done, you can now install the radio box lid. The gasket attached to the receiver box and the gasket attached to the receiver box lid will squeeze against the servo, speed control, and antenna wires.

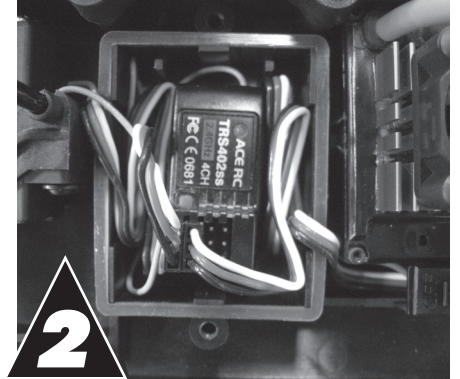
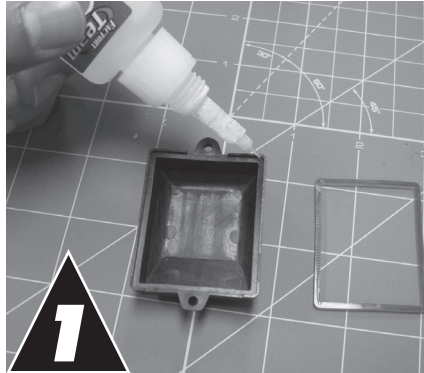

:: Wiring Diagrams

Motor and Receiver Wiring:

1. If motor runs in reverse when you apply throttle, unplug any two of the motor wires and switch them.
2. Your Receiver has multiple channel ports for plugs.

Channel 1 - you should always plug your steering servo into this channel port.

Channel 2 - you should always plug your speed control (ESC) into this channel port.

Channel 3 - Used for optional equipment such as fans, lights, ect...

Batt - Used for optional receiver battery pack. Not used in this model.

Negative black wires on steering servo and speed control plugs should face the outside edge of receiver where channel markers are located.

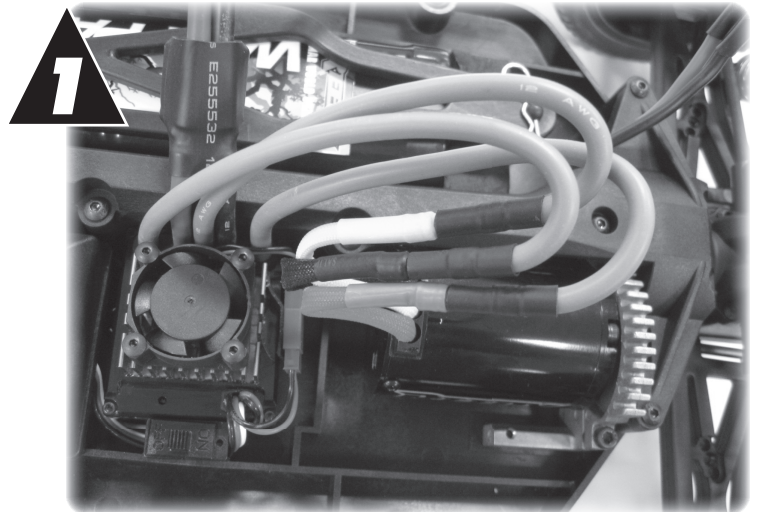

:: Wiring Diagrams - (cont.)

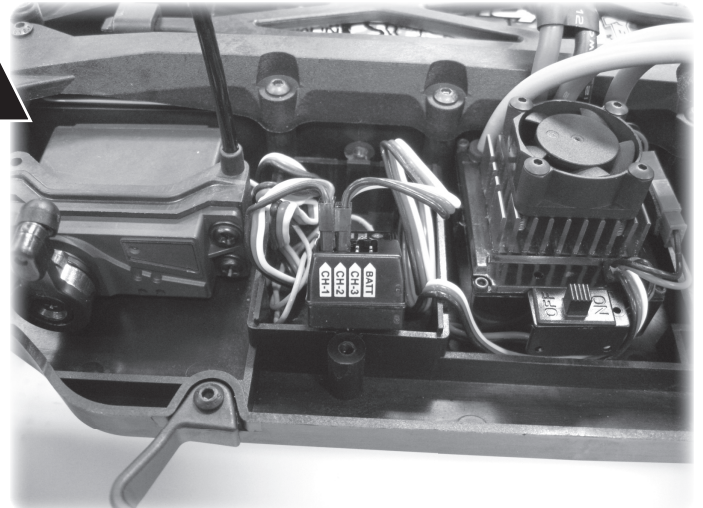
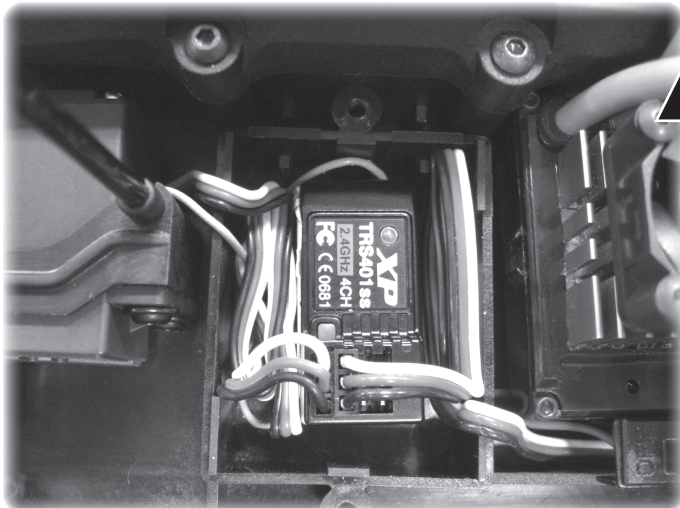

:: Gear Mesh

Gear Mesh:

To correctly set your gear mesh, follow the steps below:

1. Remove the Chassis Brace. Loosen the set screw on the motor's pinion gear. Slide the pinion on the motor shaft until the gear face of the pinion is entirely aligned with the gear face of the spur gear (see diagram). Tighten the set screw while ensuring it is aligned with the flat face on the motor shaft.

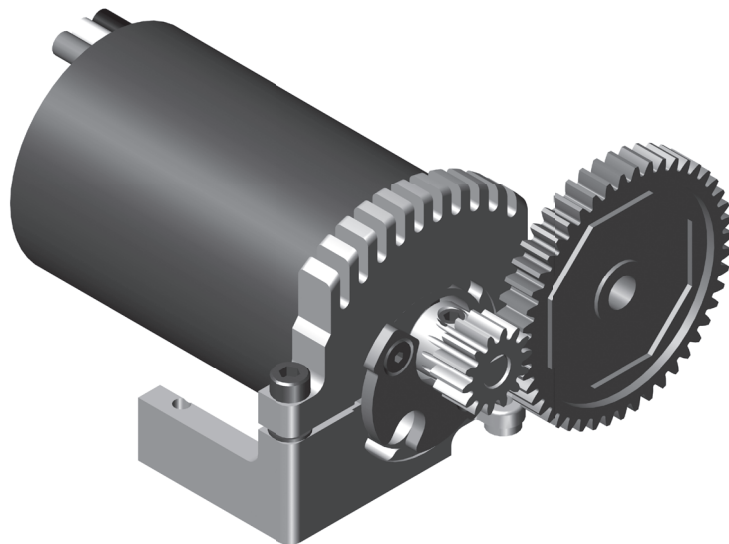
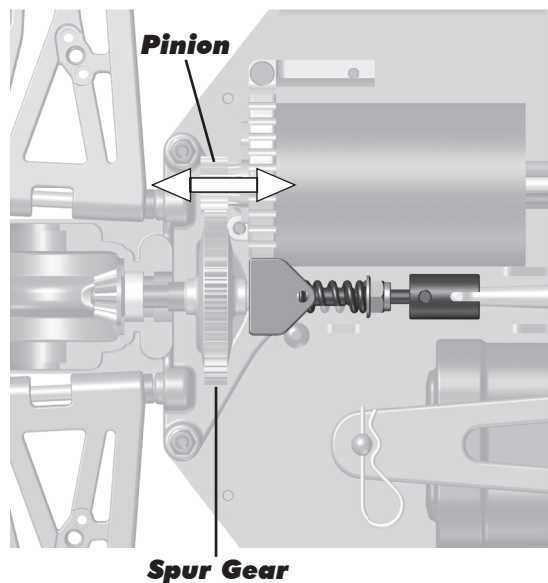

2. Loosen the motor clamp screw until the motor is able to move freely. Rotate the motor as far as it can go towards the spur gear, ensuring that the teeth of the pinion and the spur gear are interlocking. Slide the motor back (approximately 0.5 mm), and tighten the motor clamp screw. Proper gear mesh has been achieved when the teeth are meshing closely, but the gears still have a small amount of clearance between them. If you hold one gear, you should be able to rock the other gear back and forth a small amount. If there is no clearance, your gear mesh is too tight and you should readjust the motor again.

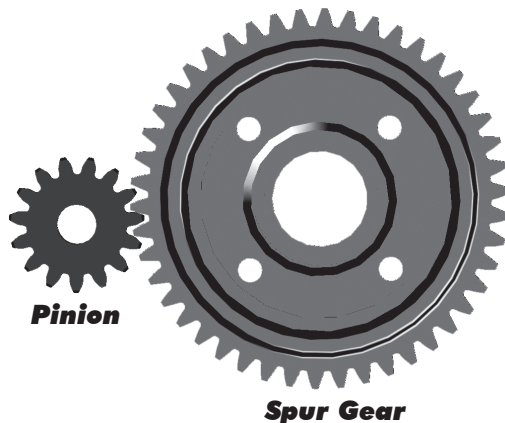

:: Ride Height

Adjusting Ride Height:

Ride height is adjusted by adding and/or removing shock pre-load clips to the front and rear shocks. Stock setting is approximately 35mm front and rear. Check the ride height with the FT Ride Height Gauge (# 1449) by lifting up the entire vehicle about 8-12 inches off the bench and drop it. After the suspension "settles" into place, then raise or lower the ride height with the shock clips as necessary and recheck. Getting the front and rear arms level is a good starting point.

Front shock: 4mm

Rear shock: 4mm

**7149
Shock
pre-load
clips**

1mm

2mm

4mm

6mm

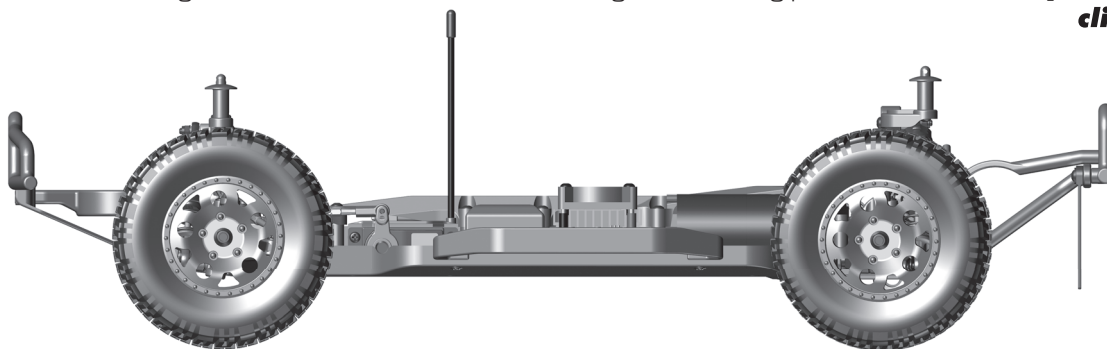

:: **Camber / Toe**

Front Camber Angle:

A good starting camber setting is -2 degrees (where the top of the tires lean inwards). Positive camber, where the top of the tire is leaning out, is typically not recommended.

Front Toe-In:

Zero degree toe-in (tires pointing straight forward) is a good starting setting. You can increase steering into corners by adding 1-2 degrees of toe-out (front of tires point slightly outward). Front toe - in is not a typical tuning adjustment used.

Rear Camber:

A good starting camber setting is -2 degrees. Use # 1719 camber gauge (not included) to set your camber. Adding a small amount of positive camber, where the top of the tire is leaning out, will tend to improve straight-line acceleration on loose tracks.

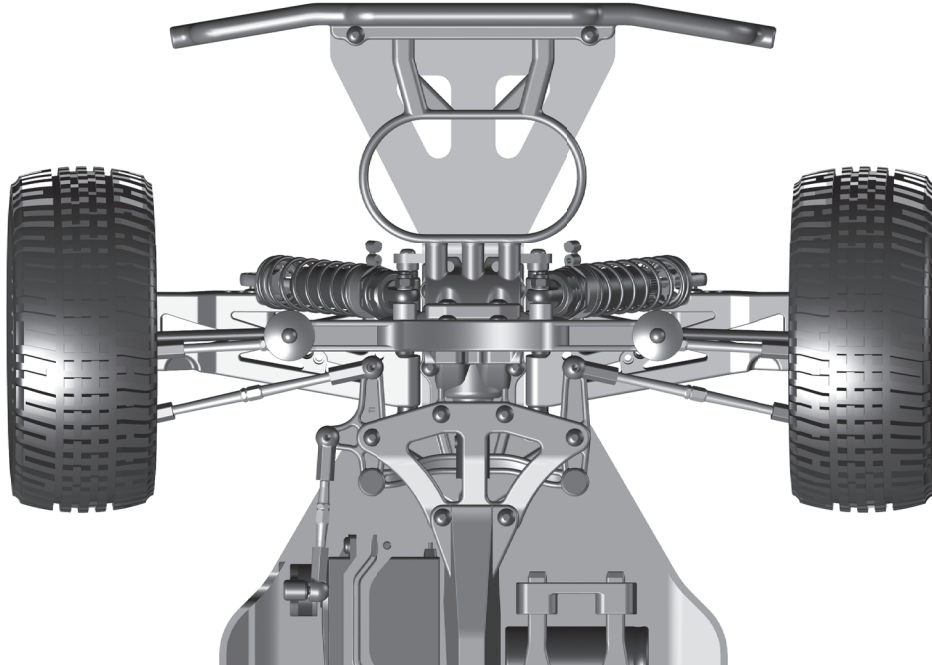

:: **Slipper Adjustments**

Adjusting the Slipper:

To adjust the slipper, use a 7mm open end wrench or some pliers to grip the slipper nut. Roll the vehicle forward to tighten the slipper; roll the vehicle backwards to loosen the slipper.

TIP: for easier slipper adjustment, remove the chassis brace, battery brace, and battery as shown!

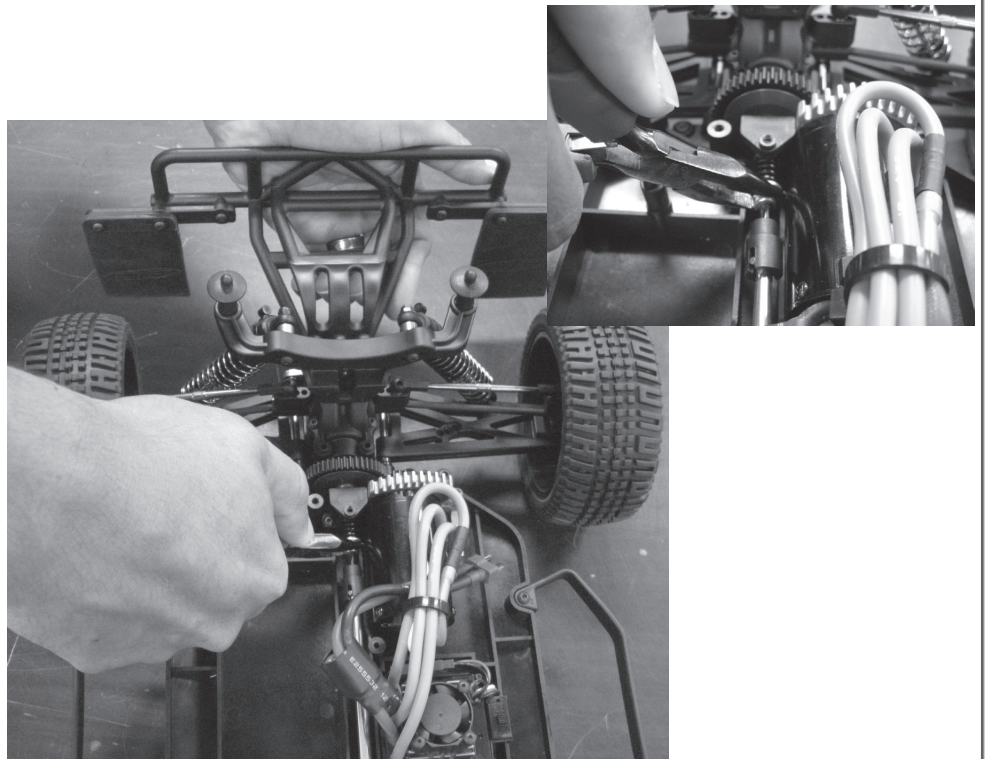

3.5mm-4.0mm of thread showing

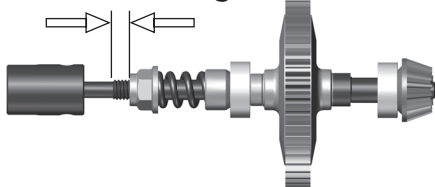

:: Spur Gear Access

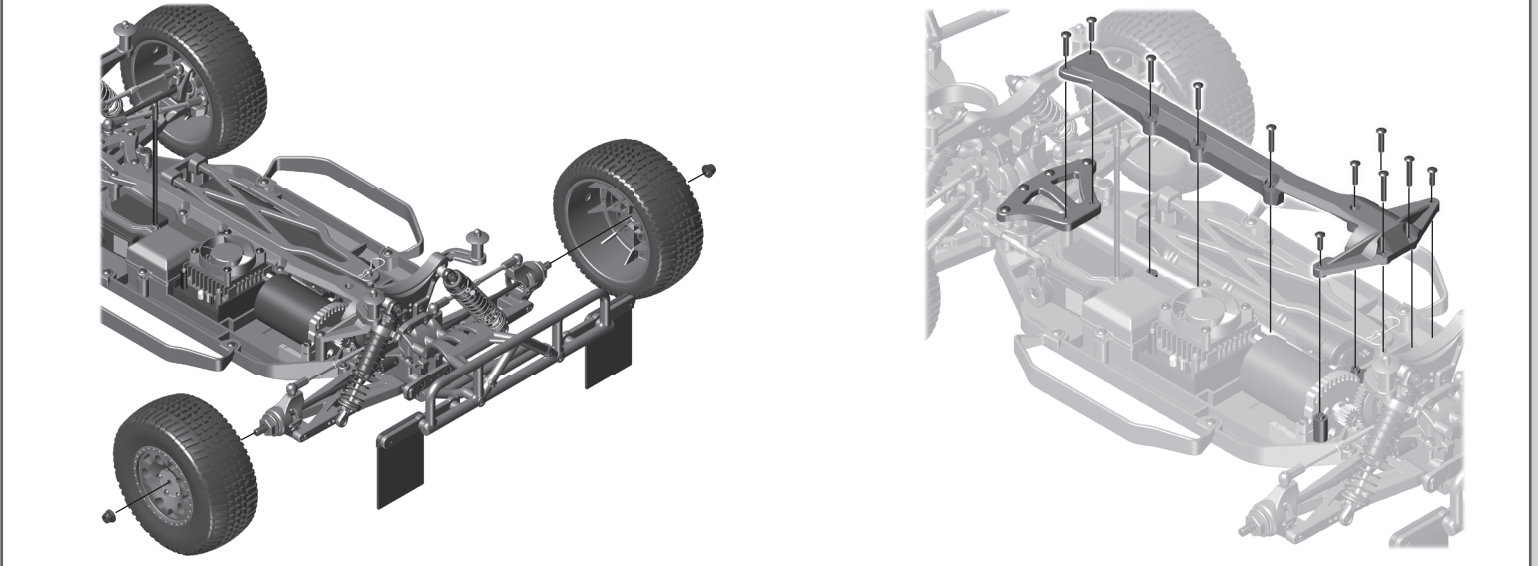

:: Spur Gear Access - (cont.)

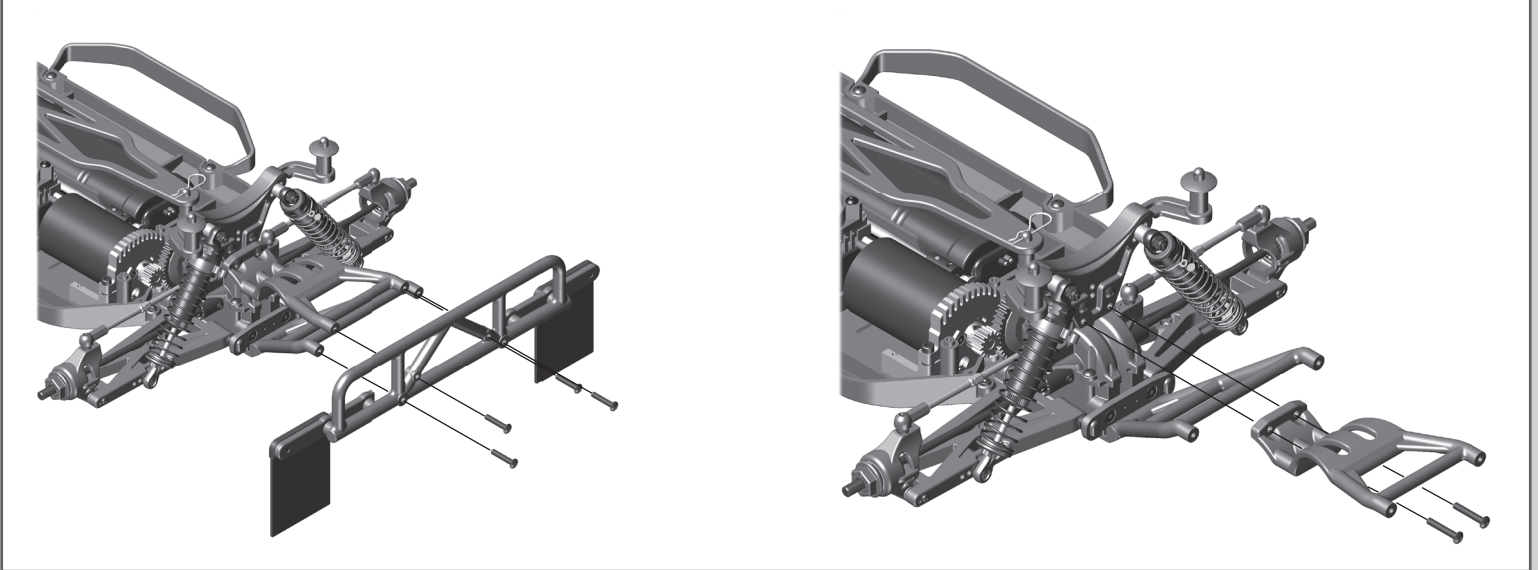

:: Spur Gear Access - (cont.)

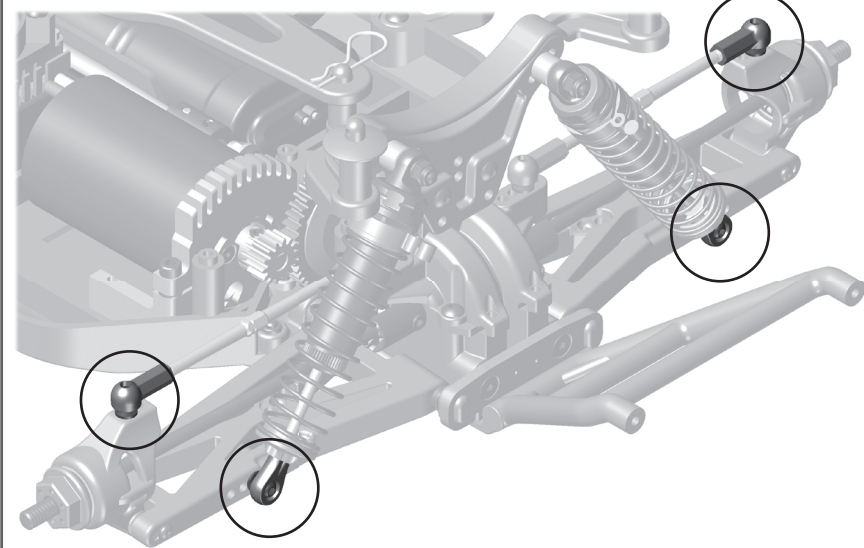

Rear Shock Tower Removal:

Loosen the ball studs highlighted in order to remove the shock tower with the shocks and camber turnbuckles attached as one complete piece.

The dogbones will come out when the shock tower is removed. Make sure you replace them when re-installing the rear shock tower!

:: Spur Gear Access - (cont.)

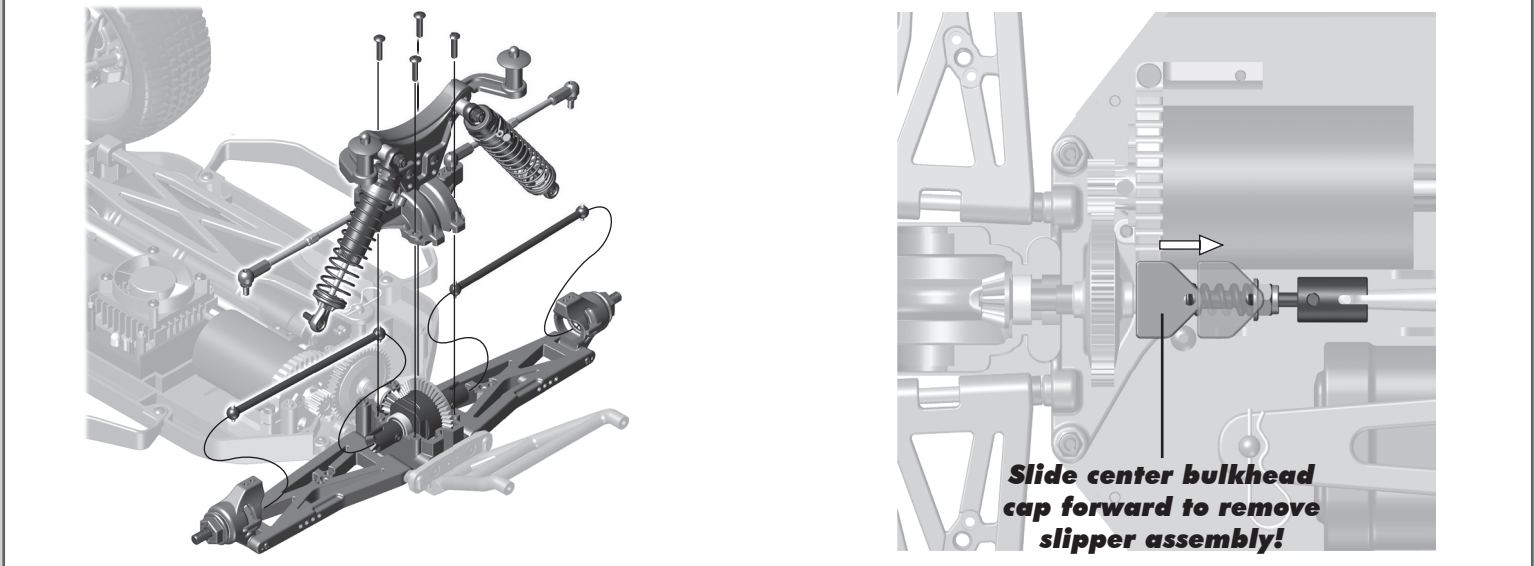

:: Spur Gear Access - (cont.)

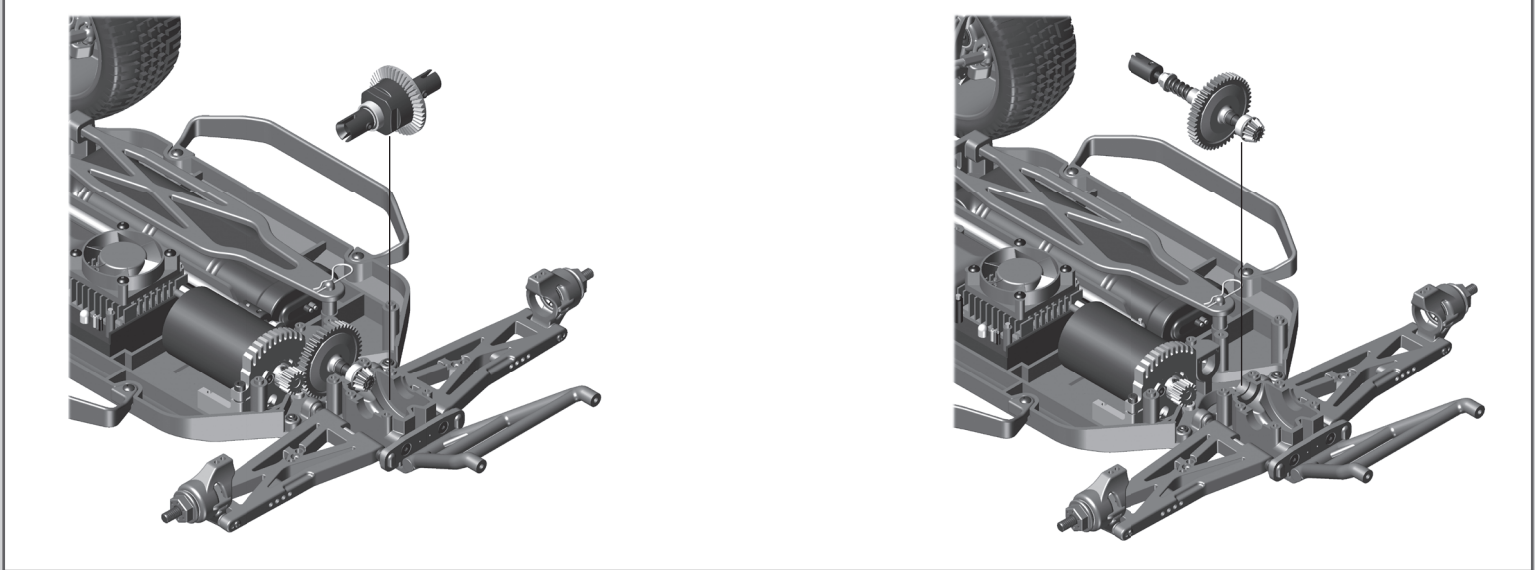

:: Spur Gear Access - (cont.)

Spur Gear Maintenance:

When accessing your spur gear, check for wear on the teeth of the gear. The teeth should be nice and sharp. Also, check the slipper pads for wear. Replace if necessary.

A good starting point for slipper setup is to have 3.5 to 4.0mm of thread showing on the shaft.

3.5mm-4.0mm of thread showing

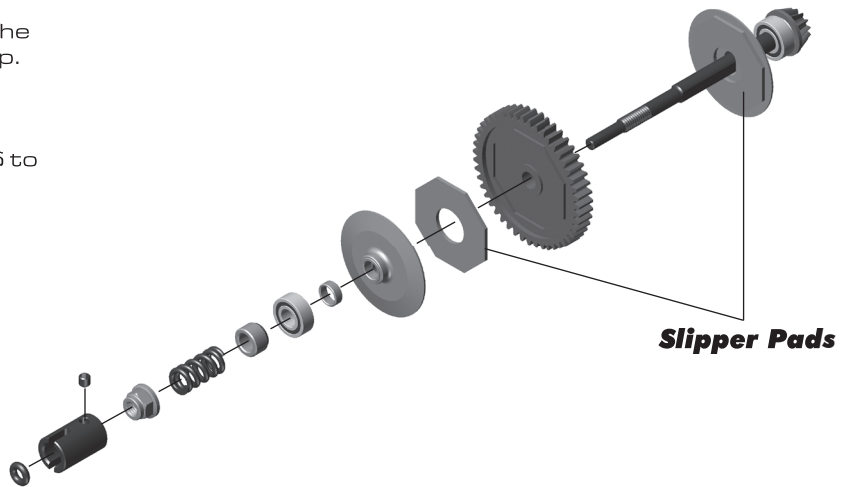
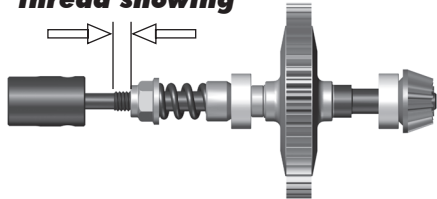

:: Front Diff Access

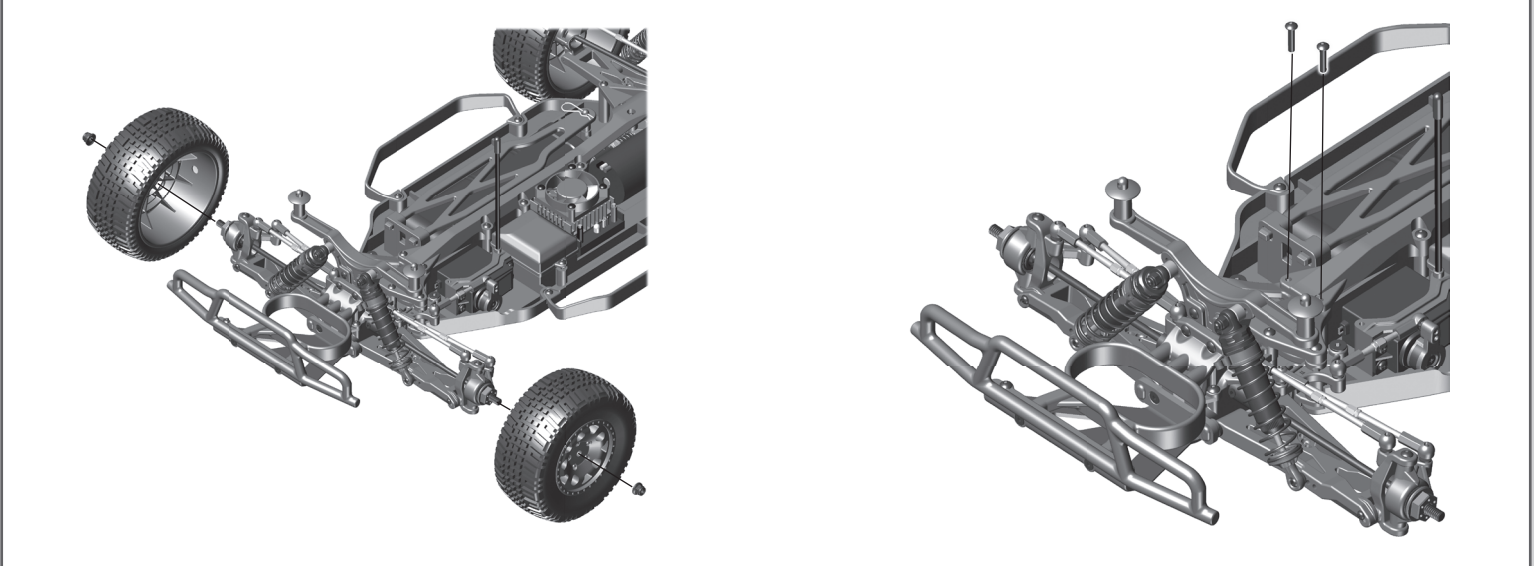

:: Front Diff Access - (cont.)

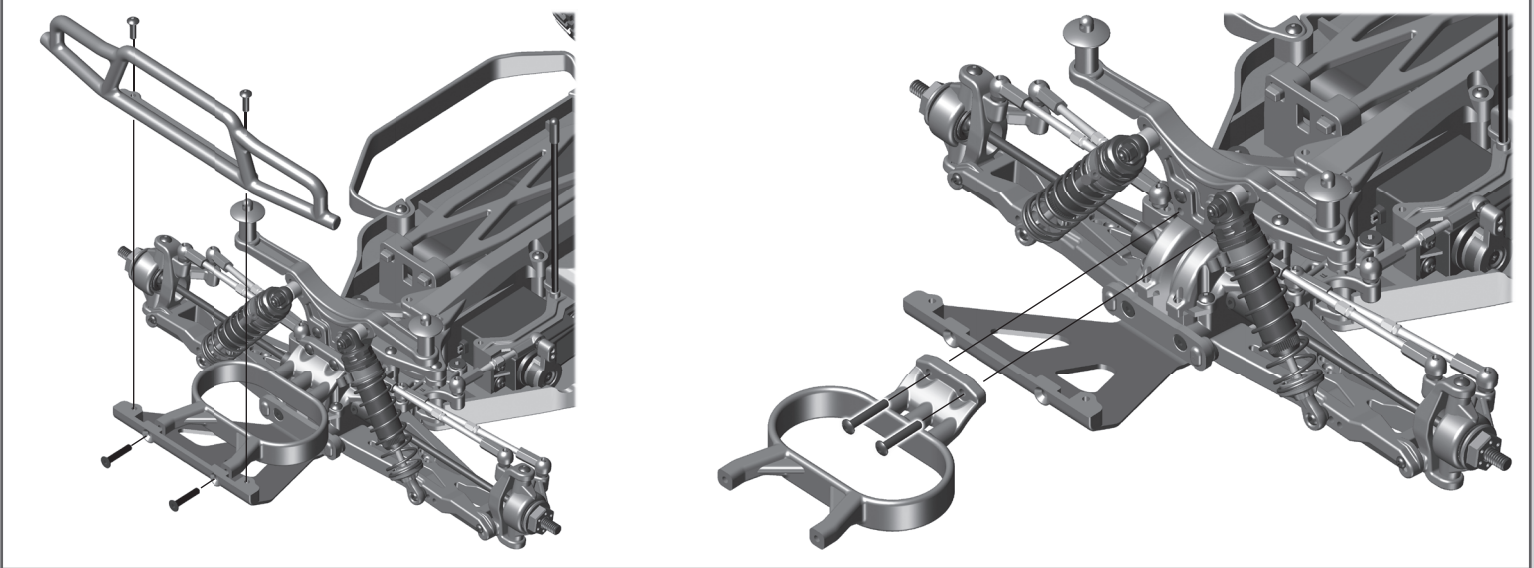

:: Front Diff Access - (cont.)

Front Shock Tower Removal:

Loosen the ball studs highlighted in order to remove the shock tower with the shocks and camber turnbuckles attached as one complete piece.

Make sure you re-install the CVA bones into the diff outdrives when re-installing the front shock tower!

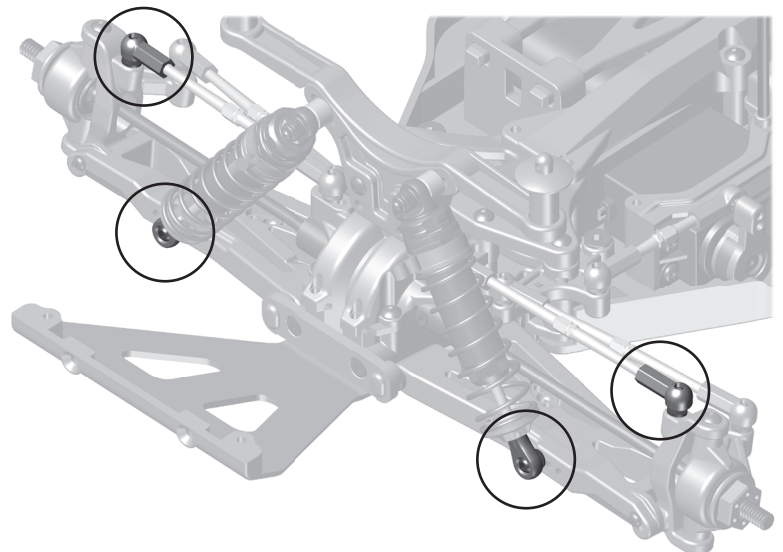

:: Front Diff Access - (cont.)

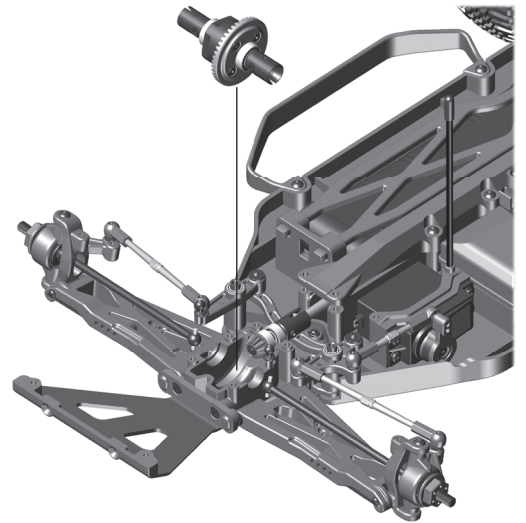
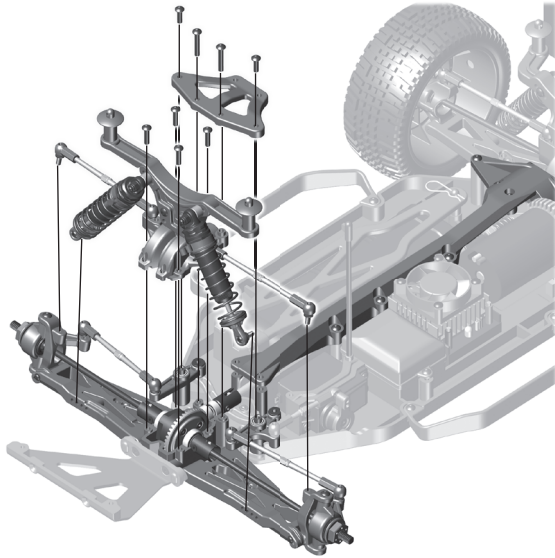

:: Diff Maintenance

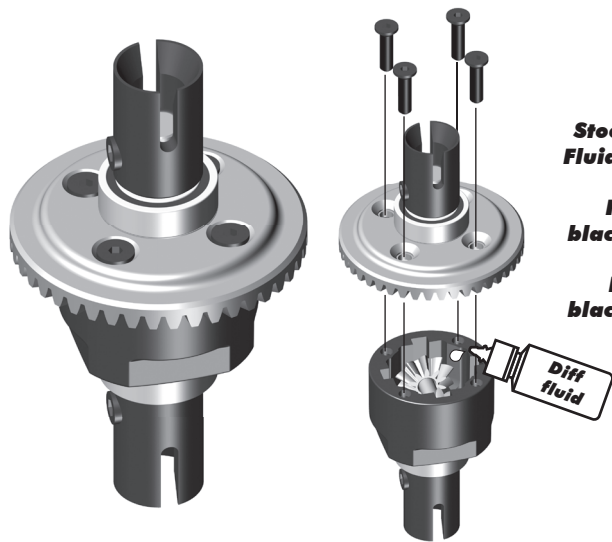

Stock Shock Fluid Setting:

Front:
black grease

Rear:
black grease

Differential Maintenance:

Once you have removed the Diff gear, you can now drain the existing diff fluid from the differential.

Check the diff gasket for wear or damage. Replace if necessary

Fill the diff to the top of the cross pin with your choice of diff fluids.

Front Diff:

Thicker oil will get less low speed steering and better acceleration out of turns.

Rear Diff:

Thicker oil will rotate less in the turns and accelerate straight on power. Thinner oil will give more low speed traction.

:: Shock Maintenance

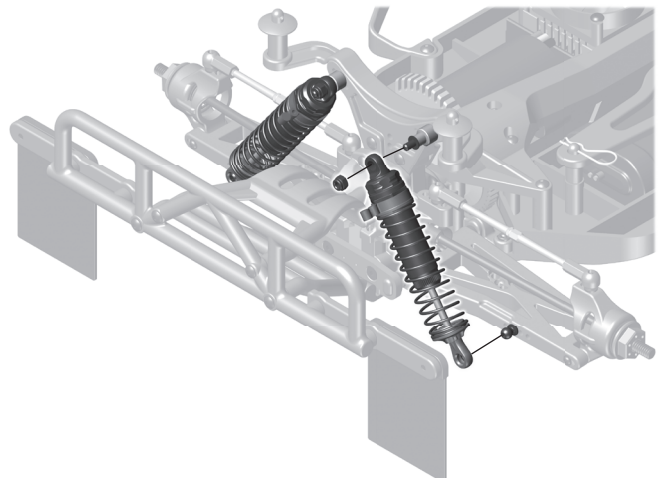
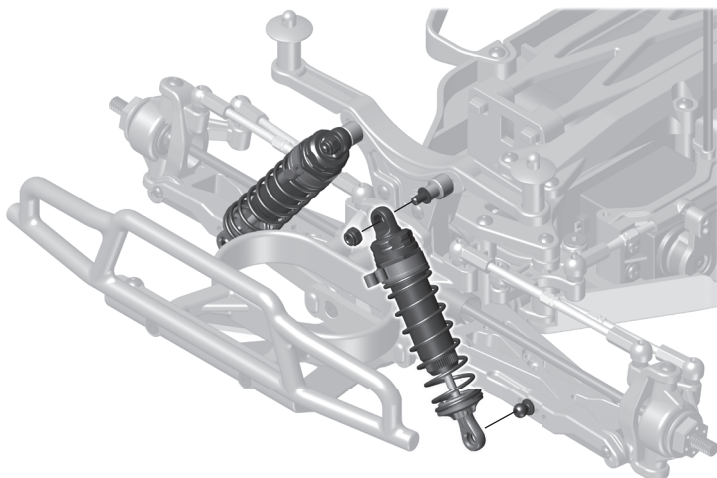

:: Shock Maintenance - (cont.)

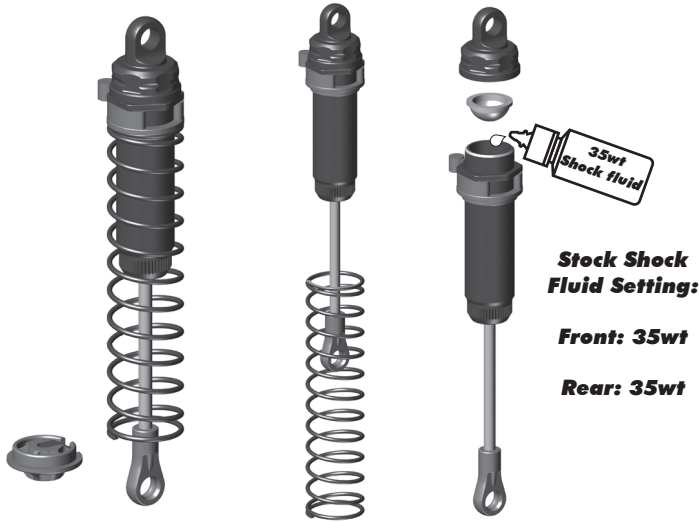

Stock Shock Fluid Setting:

Front: 35wt

Rear: 35wt

Bladder Installation

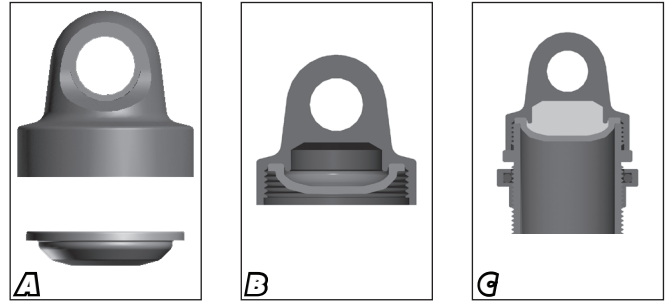

As you install the shock cap with the bladder, it will force out any extra fluid. If you install the cap with the shaft fully extended, you are running FULL REBOUND. This means the shaft will fully rebound when compressed. To run less rebound, unthread the cap 1-2 turns and compress the shaft to the desired position and re-tighten the cap with the shaft compressed. Start with no rebound.

:: Shock Maintenance - (cont.)

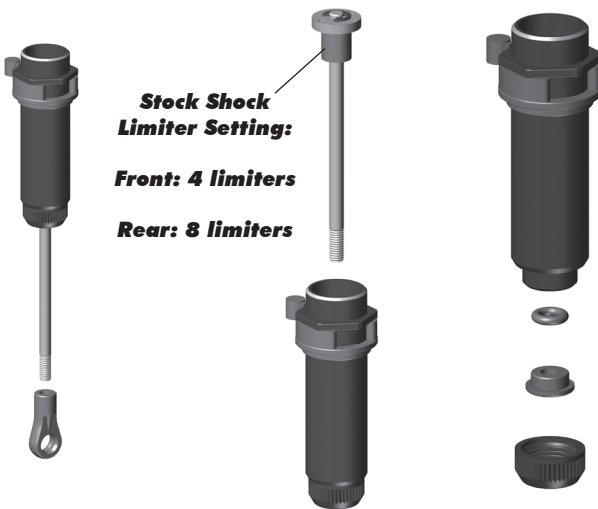

Stock Shock Limiter Setting:

Front: 4 limiters

Rear: 8 limiters

Shock Maintenance:

If you need to only refill your shocks with oil, follow the steps above only then move to the shock bleeding steps.

If your shocks leak from the bottom shock cap, follow all shock maintenance sections.

Replace the inner O-Ring in the bottom cap, then begin the shock oil filling and bleeding process.

:: Shock Maintenance - (cont.)

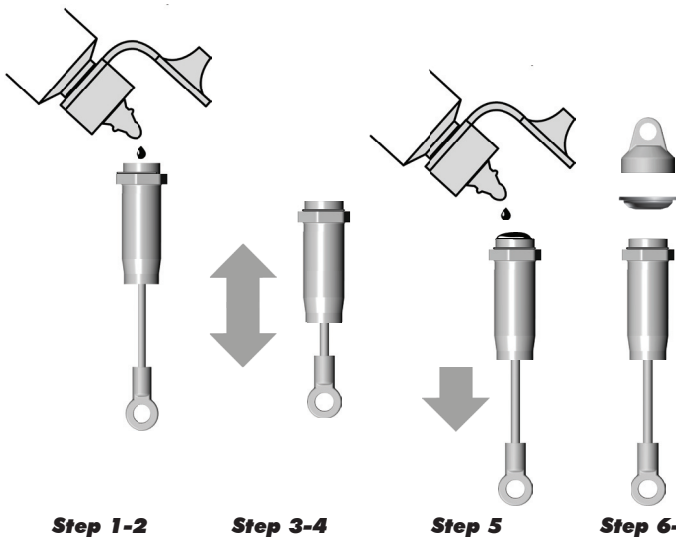

Shock Bleeding Steps:

1. Pull shock shaft down.
2. Fill shock body 3/4 full with silicone shock fluid.
3. Slowly move the shock shaft up and down to remove air from under the piston.
4. Wait for bubbles to come to surface.
5. Fill shock body to top with silicone shock fluid.
6. Place a drop of oil in the cap and on cap threads.
7. Install cap and tighten completely.
8. Unscrew the cap 3/4 turns and tilt the shock at a slight angle.
9. Slowly compress shaft all the way to bleed excess silicone shock fluid and air. You should see bubbles coming out from under the cap. (use rag around shock to catch excess fluid).
10. With the shaft compressed, tighten the cap and re-check for pressure at the top of the stroke. If there is still pressure, repeat steps 3-9.

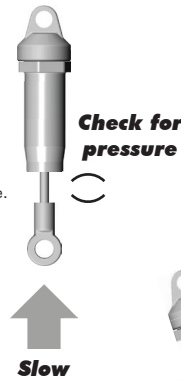

Some residual shock fluid may appear from your first few runs around the shock cap as a result of bleeding.



Step 1-2

Step 3-4

Step 5

Step 6-8

Step 9-10

:: Motor Manual**REEDY****550-SL
BRUSHLESS
MOTOR****Introduction**

Congratulations on your purchase of the Reedy 550-SL Brushless Motor. The latest brushless motor technology along with the design and engineering experience that is responsible for 29 World Championship titles has been incorporated into its design.

Due to its sensorless design, the Reedy 550-SL Brushless Motor operates powerfully and efficiently without complicated sensor harnesses. This motor is perfectly suited for use with ESCs that are designed to operate sensorless brushless motors.

Features

- Oversized Precision Ball Bearings
- High-Torque 4-Pole Rotor
- Hardened 5mm Steel Shaft
- Triple-Insulated Windings
- Sensorless Operation
- 3.5mm Connectors
- Completely Rebuildable

Because no single motor works best in all vehicles and in all conditions, two models are available to suit any application. Be sure to visit www.reedypower.com for the latest application and gearing charts for each model and to view a complete list of spare and option parts.

Please read the following before installing and using your new motor.

Precautions and Warnings

- Please read the instructions before installing and operating your motor.
- Avoid over gearing by monitoring motor temperature. Operating temperatures should not exceed 80C (175F)
- Be sure to use the proper size motor mounting screws.
- Do not over-tighten the motor mounting screws.
- Do not use a Schottky diode with this motor.

Installation and Maintenance

- Your motor should be installed using 3mm screws with a length (generally 6mm or less) that does not allow the screw to extend into the motor more than 5mm. Otherwise, the screw can damage the motor's internal components.
- Do not over-tighten the motor mounting screws. Doing so may strip the mounting hole threads.
- Connect the three leads exiting the motor to the three motor leads from your Electronic Speed Control (ESC). If the motor runs backwards when giving it forward throttle, reverse any two motor leads. The motor will now turn in the desired direction.
- To clean your motor, lightly brush dirt away on a regular basis paying particularly close attention to the areas around the ball bearings. DO NOT spray cleaners or solvents into the motor.

Caution

When switching to a higher voltage battery from a lower one (11.1V to 7.4V, for example), a change in gear ratio or a lower kV motor might be necessary. Otherwise, the motor or ESC may overheat and sustain permanent damage. Please visit www.reedypower.com for the latest gear ratio suggestions for your particular motor and vehicle.

Safety Precautions

This product is a sophisticated hobby product and not a toy. It must be operated with caution and common sense and requires some basic mechanical ability. Failure to operate this product in a safe and responsible manner could result in injury or damage to the product or property. This product is not intended to be used by children without direct adult supervision. It is essential to read and follow all instructions and warning found in this manual prior to installation, set up, and use in order for the product to operate properly and to avoid damage or injury.

Specifications

Model	550-SL 3500kV	550-SL 4000kV
Item No.	924	925
Cells	2-3 LiPo, 4-8 NiMH	2-3 LiPo, 4-8 NiMH
RPM/Volt	3500	4000
Diameter	36mm	36mm
Length	55mm	55mm
Weight	210g/7.4oz	200g/7.1oz
Shaft Diameter	5.0mm	5.0mm
Max. Efficiency Current	10~45A	10~50A
Max. Surge Current	55A/60s	60A/60s
Internal Resistance	6.5mΩ	6.2mΩ

Warranty

Your motor is warranted to the original purchaser for 30 days from the date of purchase against defects in material and workmanship. Motors that have been mishandled, abused, used incorrectly, used for an application other than intended or damaged by the user are not covered under warranty.

Associated Electrics Inc. is not liable for any loss or damage, whether direct or indirect, incidental or consequential, or from any special situation, arising from the use, misuse, or abuse of this product.

:: ESC Manual



**SC900-BL
SC1300-BL
Brushless ESC**

#111776

INTRODUCTION

Congratulations on your XP Brushless Electronic Speed Control (ESC) purchase. The latest electronics technology along with the design and engineering experience that is responsible for multiple World Championship titles has been incorporated into its design.

Your XP Brushless ESC is water-resistant for maximum durability. Its light and compact design allows for easy installation in most 1/10 vehicles. Simple calibration and a wide variety of tuning options make this ESC perfect for both casual enthusiast and racers. When paired with a Reedy Brushless Motors, you create a potent combination of power and efficiency that brings performance to a new level. More power and less maintenance elevate the fun factor by increasing top speeds and reducing down time.

Please read the following instructions before installing and operating your ESC.

FEATURES

- Adjustable LiPo Low-Voltage Cutoff
- LiPo Cell Auto Detect
- Reversible With Reverse Lockout
- Fully Proportional Brakes
- Adjustable Drag Brakes
- Adjustable Throttle Profile
- Hard Case with Aluminum Heat Sink
- Water Resistant
- Heavy Duty Silicone Wires
- Deans® Ultra Plug® Connector
- Pre-Wired For Optional Cooling Fan

SPECIFICATIONS

	#29139	#29145
Description	XP SC900-BL	XP SC1300-BL
On Resistance	0.9 mΩ x 2	0.5 mΩ x 2
Motor Limit	2 Lipo, 5500kV 3 LiPo, 4000kV	2 Lipo, 6100kV 3 LiPo, 4000kV 4 LiPo, 2650kV
Cells	2-3 LiPo, 6-8 NiMH	2-4 LiPo, 6-8 NiMH
Motor Connector	3.5mm Sockets	4.0mm Sockets
Batt. Connector	Deans®	
Brakes	Proportional	
Reversible	Yes, w/Brakes Only Option	
Low Volt Cutoff	Adjustable w/Cell Auto-Detect	
Dimensions	46mm x 42mm x 26mm	
Weight w/Wires	100g (3.5 oz)	
Power Wires	12-Gauge Silicone	

INSTALLATION AND MAINTENANCE

- Mount your ESC securely using high quality double-sided tape.
- Install your ESC in a position that allows easy access to all connectors.
- Plug the ESC receiver wire into the receiver (refer to radio manufacturer's manual)
- To prevent radio interference, arrange ESC wiring so that it is not in close proximity to the receiver antenna wire.
- Connect the three motor leads exiting the ESC to the three leads exiting your motor. If the motor runs backwards when giving it forward throttle, reverse any two motor leads. The motor will now run the desired direction.
- Mount the switch to the case using the tab provided.
- Always power ON your transmitter before the ESC and power OFF the ESC before the transmitter.

SAFETY PRECAUTIONS

This product is a sophisticated hobby product and not a toy. It must be operated with caution and common sense and requires some basic mechanical ability. Failure to operate this product in a safe and responsible manner could result in injury or damage to the product or property. This product is not intended to be used by children without direct adult supervision. It is essential to read and follow all instructions and warnings found in this manual prior to installation, set up, and use, in order for the product to operate properly and to avoid damage or injury.

THROTTLE CALIBRATION

Your new ESC must be calibrated before use. Before calibration, be sure to set your radio's throttle and brake EPAs to 100% and your throttle trim to neutral. Then follow the steps outlined below.

Step	Procedure	Signal From ESC	
		Audio	LED
1	Power ON transmitter		
2	Throttle trigger position to maximum		
3	Power ON ESC	bibibibibi	red static/6 green flash
4	Throttle trigger position to neutral	bibi-bibi	red static/4 green flash
5	Throttle trigger position to maximum brake	bibi-bibi	red static /4 green flash
6	Throttle trigger position to neutral		red static
7	Power OFF ESC		
8	Power OFF transmitter		

Once the calibration procedure is complete, turn on your transmitter, then your ESC, and begin operating your vehicle. Note: If you choose to make settings adjustments at this time, you can do so immediately after step #6 of the throttle calibration procedure.

PROGRAMMABLE SETTINGS

Your ESC comes pre-programmed and can be used immediately. But you can also change the setting based on the type of vehicle and battery used as well as personal performance preferences based on the track you are driving on and your driving style.

DRAG BRAKE - Drag brake is the amount of braking achieved when the throttle is returned to neutral. A setting of 0% means the vehicle will free wheel to a stop while higher settings will stop the car faster. Please note that regardless of the drag brake setting, you will still be able to use the brake trigger to manually slow the car. This push brake action can be adjusted by changing your transmitter's brake EPA setting.

THROTTLE PROFILE - This setting adjusts the power delivery of your ESC/motor combination. The Very Soft setting can be used on loose or bumpy track to reduce wheel spin while the Maximum setting works well when high traction is available. Four settings provide options for any track condition.

RUN MODE - This gives the option of using reverse or eliminating it completely (for competition). With reverse activated, you will still have fully proportional braking. Reverse can be engaged after the vehicle has come to a complete stop and the throttle trigger is returned to neutral. At this time, pushing back on the trigger reverses the vehicle.

BATTERY MANAGEMENT SYSTEM - A choice of either LiPo mode or NiMH mode adjusts the low voltage cutoff point. This is particularly important when using LiPo batteries that should not, for performance and safety reasons, be discharged below 3.0V per cell. In LiPo mode, the ESC detects whether you are using 2 or 3 cells and adjusts the cutoff accordingly.

To make settings adjustments, you must first follow the calibration procedure. After step #6, you will encounter a 5-second delay before entering the settings adjustment mode. All changes will be made using your transmitter's throttle trigger. Note: Once you enter the settings adjustment mode, the ESC will scroll through all options. If you fail to choose a setting, the ESC will keep the previously saved setting.

For example, if you want to change the throttle profile from Soft to Standard, enter the settings mode. You will encounter the Battery management System and Drag Brake modes first at which time you can let the ESC scroll through the choices (the previously saved setting will be kept) until you reach the Throttle Profile choices. You must make the selection by pulling the throttle trigger to maximum after the ESC scrolls to the desired setting (in this case Standard) indicated by the appropriate audible tones. Once this setting (or any setting for that matter) is chosen, you can skip to Step #5 if no other changes are desired.

Step	Procedure	Signal From ESC	
		Audio	LED
1	Battery Management System		
	NiMH 4.5V Cut-Off (default SC900)		red static/green flashes
	LiPo 3.0V Cell Cut-Off (default 3.2V SC1300)		
	Throttle trigger position to maximum to select value	bibi-bibi	red static/4 green flash
	Throttle position to neutral		red static
2	Drag Brakes		
	0% (default SC1300-BL)		red static/green flashes
	2.5% (default SC900-BL)		
	5%		
	10%		
	Throttle trigger position to maximum to select value	bibi-bibi	red static/4 green flash
	Throttle position to neutral		red static
3	Throttle Profile		
	Very Soft		red static/green flashes
	Soft (default SC900-BL)		
	Standard (default SC1300-BL)		
	Maximum		
	Throttle trigger position to maximum to select value	bibi-bibi	red static/4 green flash
	Throttle position to neutral		red static
4	Run Mode		
	Reverse Off (Forward Only)		red static/green flashes
	2-stage Reverse (default)		
	Throttle trigger position to maximum to select value	bibi-bibi	red static/4 green flash
	Throttle position to neutral		
5	Power OFF ESC and transmitter		
6	Power ON transmitter and ESC	melody bi-bi	2 red flash/green static

:: Shocks

4187	Nylon Spacer .030	12
5407	Red Silicone O-Ring	8
7143	Rear Shock Kit	2
7144	Front Shock Kit	2
7145	Shock Bodies, FR/RR w/ Top & Bottom Caps, & Hat Bushings	2ea
7146	Shock Bladders	4
7147	Shock Shafts, FR/RR w/Rod Ends (4)	2ea
7148	Pistons, 1.2, 1.3, 1.4 w/E-Clips	4ea
7149	Shock Clips w/Spring Retainer (4), Spring Cup (4), & Rod Ends (4)	4ea
7150	Shock Springs, Soft FR/RR	2ea
7151	Shock Springs, Medium FR/RR - Kit	2ea
7152	Shock Springs, Hard FR/RR	2ea
25231	E-Clip, 2.5mm	20

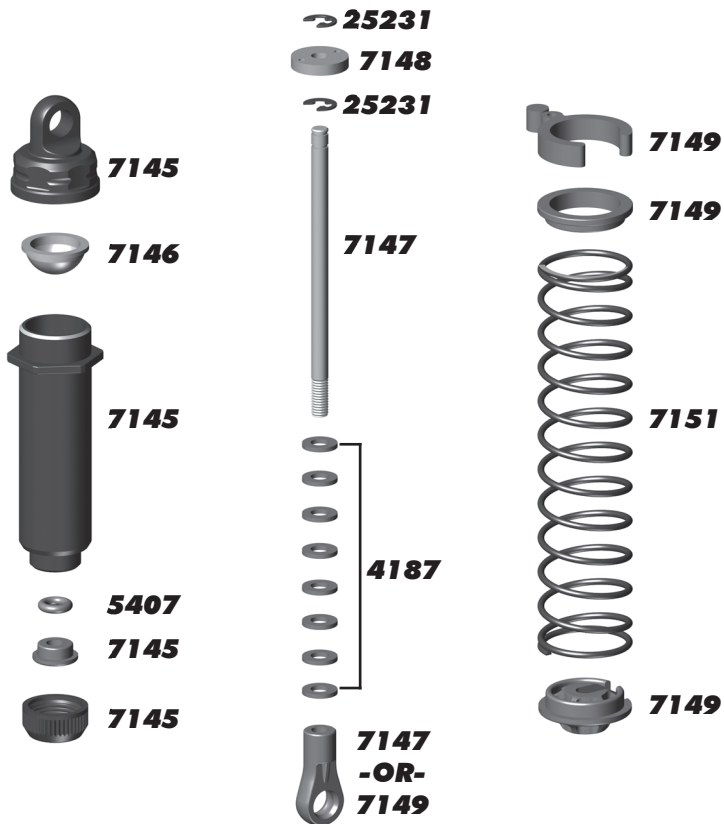

:: Servo Saver/Mount

6338	Antenna Tube w/Cap	1
7137	Servo Mount	1
7138	Servo Saver	1
7163	Ball Stud, (3 short/7 long) Set	1
7167	Tap Screw BHPS	10
25202	M3x10mm FHCS	20

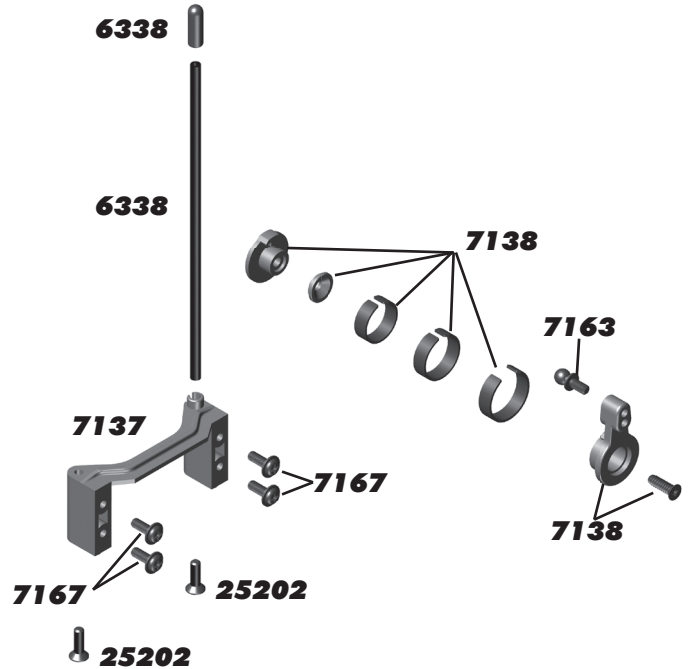

:: Steering

7139	Bellcrank Assembly, Set	1
7163	Ball Stud, (3 short/7 long) Set	1
31400	Bearing, 5x8mm	2

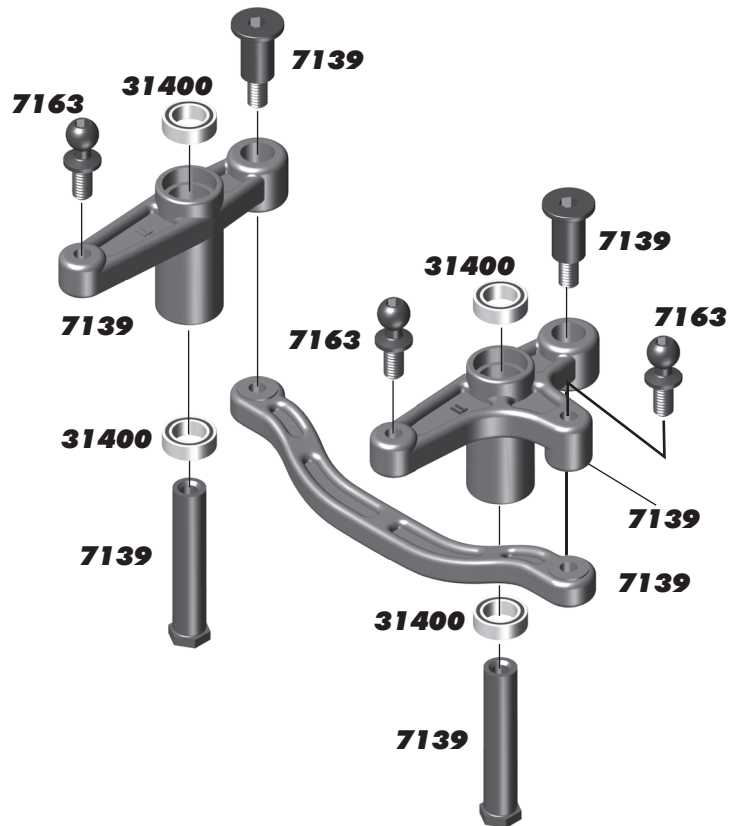

:: Shock Fluid

5420	10 Weight Silicone Shock Fluid	2oz.
5421	20 Weight Silicone Shock Fluid	2oz.
5422	30 Weight Silicone Shock Fluid	2oz.
5423	40 Weight Silicone Shock Fluid	2oz.
5424	22.5 Weight Silicone Shock Fluid	2oz.
5425	80 Weight Silicone Shock Fluid	2oz.
5426	27.5 Weight Silicone Shock Fluid	2oz.
5427	15 Weight Silicone Shock Fluid	2oz.
5428	25 Weight Silicone Shock Fluid	2oz.
5429	35 Weight Silicone Shock Fluid	2oz.
5430	45 Weight Silicone Shock Fluid	2oz.
5431	55 Weight Silicone Shock Fluid	2oz.
5432	32.5 Weight Silicone Shock Fluid	2oz.
5433	37.5 Weight Silicone Shock Fluid	2oz.
5434	42.5 Weight Silicone Shock Fluid	2oz.
5435	50 Weight Silicone Shock Fluid	2oz.
5436	60 Weight Silicone Shock Fluid	2oz.
5437	70 Weight Silicone Shock Fluid	2oz.
5438	47.5 Weight Silicone Shock Fluid	2oz.

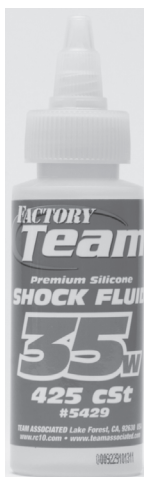

:: Front and Rear Gear Differential

7133	Diff - Complete	1
7134	Diff Outdrive w/Set Screw	2
7732	M4x4mm Set Screw	6
25607	Bearing, 8x14x4	4
31350	M2.5x10mm FHCS	6

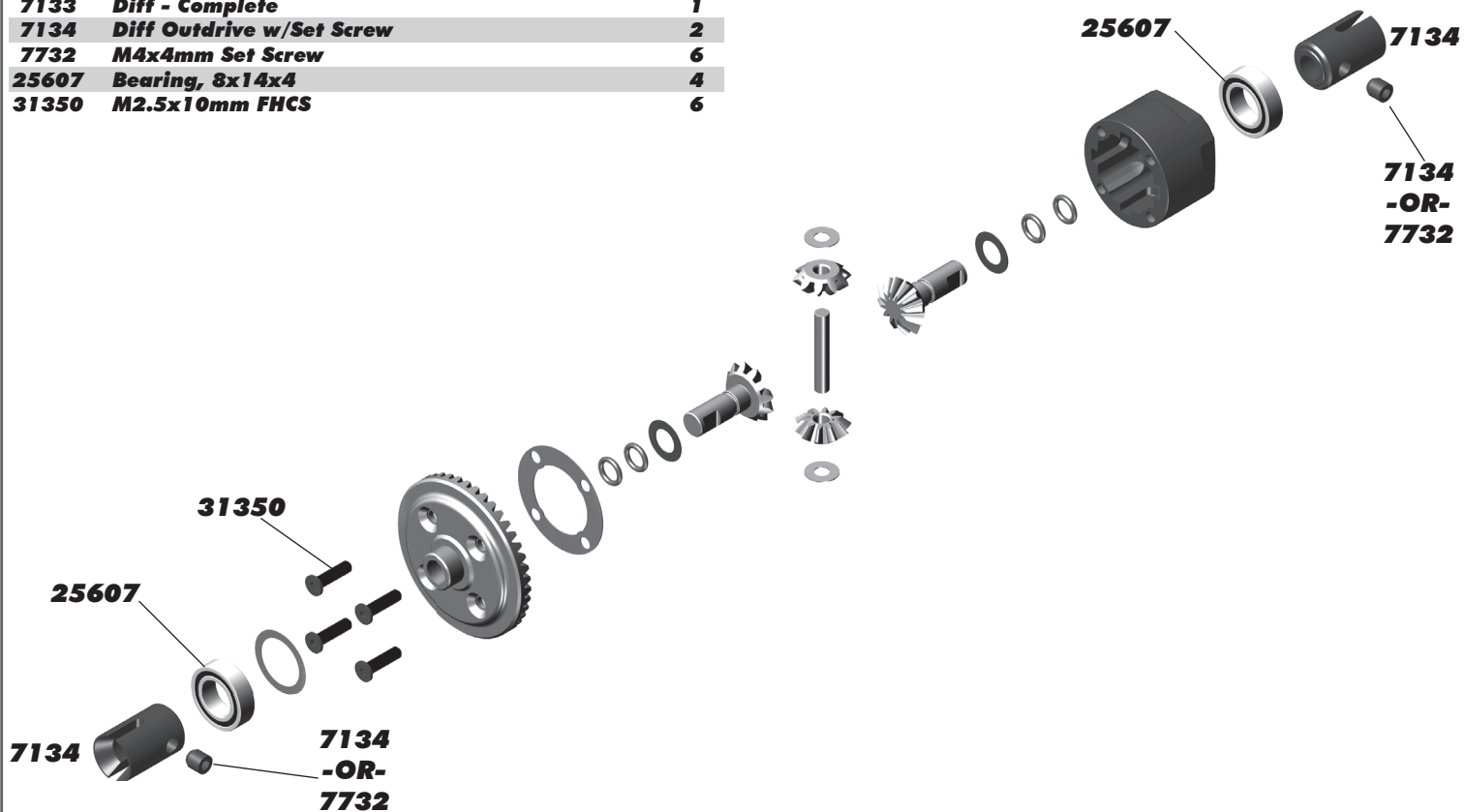

:: Lubes & Adhesives / Decals / Misc.

1105	FT Green Slime Shock Lube	1
1596	FT Locking Adhesive	1
1597	FT Tire Adhesive, Medium	1
5450	Silicone Diff Fluid 1000cst	1
5451	Silicone Diff Fluid 2000cst	1
5452	Silicone Diff Fluid 3000cst	1
5453	Silicone Diff Fluid 5000cst	1
5454	Silicone Diff Fluid 7000cst	1
5455	Silicone Diff Fluid 10000cst	1
5456	Silicone Diff Fluid 20000cst	1
5457	Silicone Diff Fluid 30000cst	1
5458	Silicone Diff Fluid 60000cst	1
5459	Silicone Diff Fluid 100000cst	1
6588	Black Grease - 4cc	1
6591	S.Diff Lube - 4cc	1
6636	Silicone Grease - 4cc	1
6727	Servo Tape	2
716	Reedy 2009 Sticker Set	1
717	Reedy Powered Logo Decal	1
3816	American Bumper Sticker	1
3820	AE Logo Decal Sheet	1
3834	AE Blue Embossed Logo Sticker	2



1596

:: Battery Strap

6332	Body Clips	6
7115	Battery Strap w/Wall & Post, Set	1
89209	M3x18mm FHCS	10
89455	M3x22mm FHCS	10

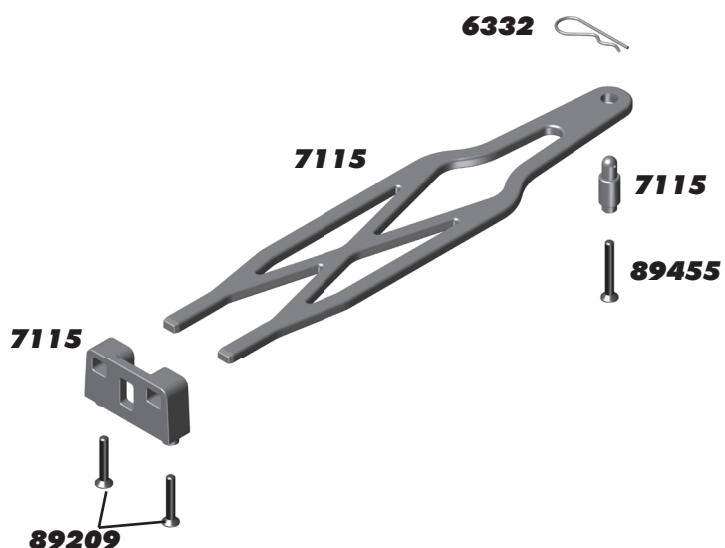

:: Front Gearbox

2308	M3x18mm BHCS	6
5407	Red Silicone O-Ring	8
7116	ProLite Chassis Braces	1
7117	Gearboxes FR/RR, Top & Bottom	1ea
7124	Front Input Shaft, Set	1
7134	Diff Outdrive, w/ set screw	2
7135	Drive Pinion	1
7155	Arm Mounts, A & D Plates	1ea
7158	Hinge Pins (inner & outer), Bushings (0, 1, 2, & arm washers) Set	1
7163	Ball Stud, (3 short/7 long) Set	1
7166	4mm E-Clip	10
7732	M4x4mm Set Screw	6
25202	M3x10mm FHCS	20
25211	M3x10mm BHCS	20
25215	M3 Locknut, black	20
25231	E-Clip, 2.5mm	20
25710	Bearing, 5 x 11 x 4	2
89202	M3x12mm BHCS	10

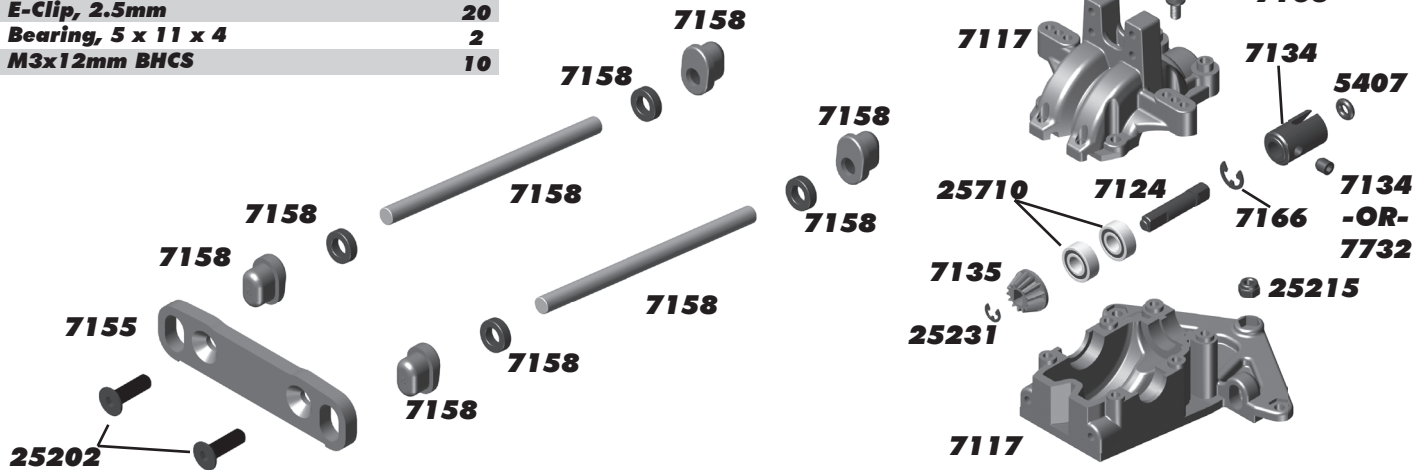

:: Front Suspension

7128	CVA Axle, Front	2
7129	CVA Bone, Front	2
7130	CVA Coupler w/Pin	2
7140	Steering & Caster Blocks	2ea
7141	Steering Block Bushing	4
7157	Front Arms w/arm washers (4) & M2x4mm BHPS screws (2), Set	1
7158	Hinge Pins (inner & outer), Bushings (0, 1, 2, & arm washers) Set	1
7163	Ball Stud, (3 short/7 long) Set	1
7165	Washer, 6x12mm	10
7168	M2x4mm BHPS, Flanged	10
25211	M3x10mm BHCS	20
25616	Bearing, 10x15x4	2
91027	4x4 Wheel Hex w/Hardware	4
91148	M4 Locknut, w/Flange & Knurl	8

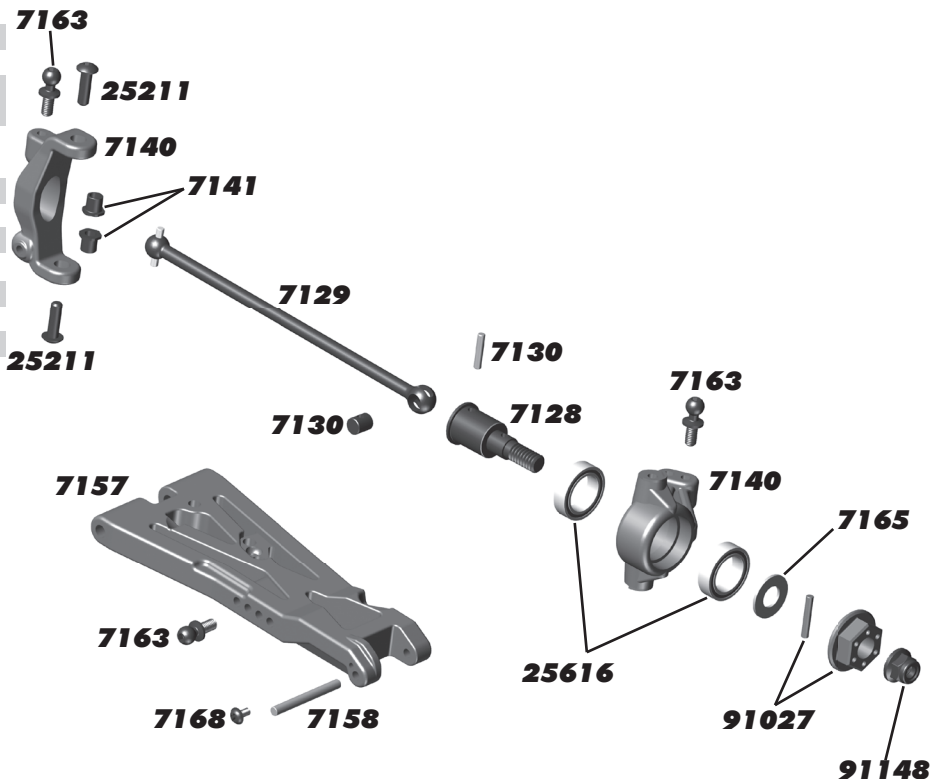

:: Rear Gearbox

7117	Gearboxes FR/RR, Top & Bottom	1ea
7155	Arm Mounts, A & D Plates	1ea
7158	Hinge Pins (inner & outer), Bushings (0, 1, 2, & arm washers) Set	1
7163	Ball Stud, (3 short/7 long) Set	1
25202	M3x10mm FHCS	20
25215	M3 Locknut, black	20
89202	M3x12mm BHCS	10

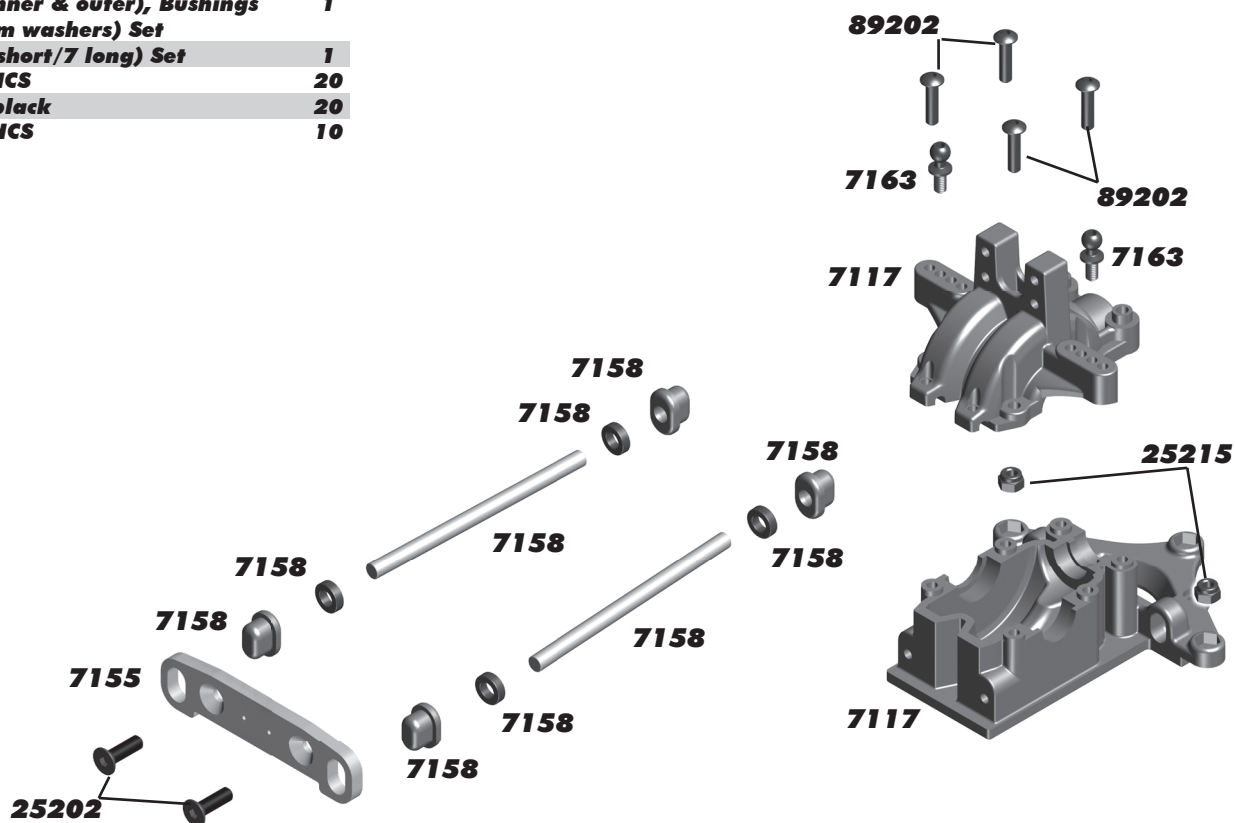

:: Rear Suspension

7131	Dogbone (RR)	2
7132	Axle/Dogbone	2ea
7142	Hub Carrier	2
7156	Rear Arms w/arm washers (4) & M2x4mm BHPS screws (2), Set	1
7163	Ball Stud, (3 short/7 long) Set	1
7158	Hinge Pins (inner & outer), Bushings (0, 1, 2, & arm washers) Set	1
7165	Washer, 6x12mm	10
7168	M2x4mm BHPS, Flanged	10
25616	Bearing, 10x15x4	2
91027	4x4 Wheel Hex w/Hardware	4
91148	M4 Locknut, w/Flange & Knurl	8

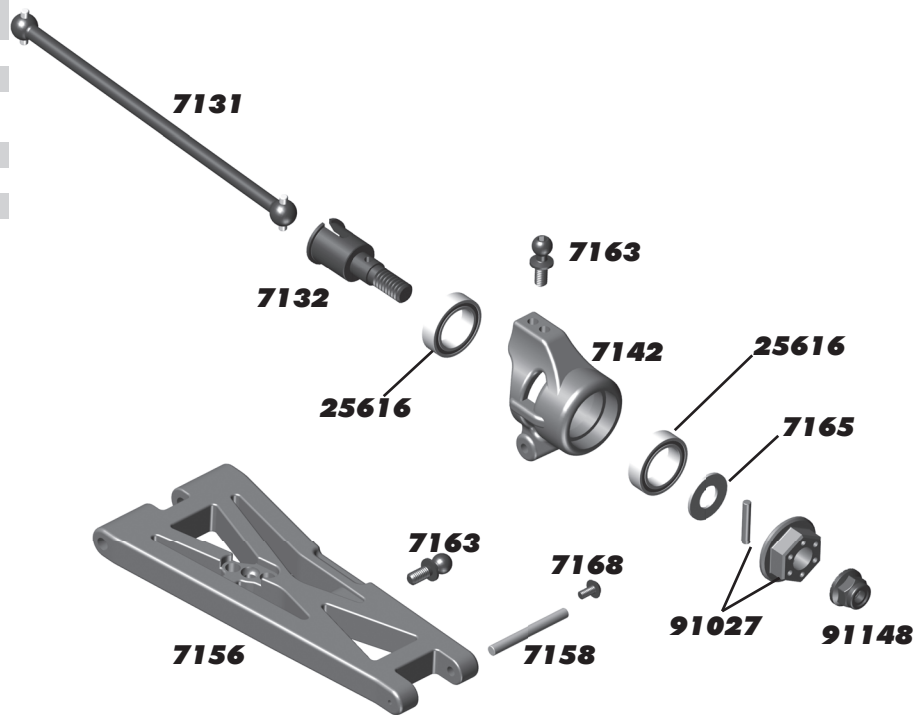

:: Front Bumper

2308	M3x18mm BHCS	6
7119	Front Bumper, Set	1
25201	M3x8mm FHCS	20
25204	M3x16mm FHCS	20
25211	M3x10mm BHCS	20

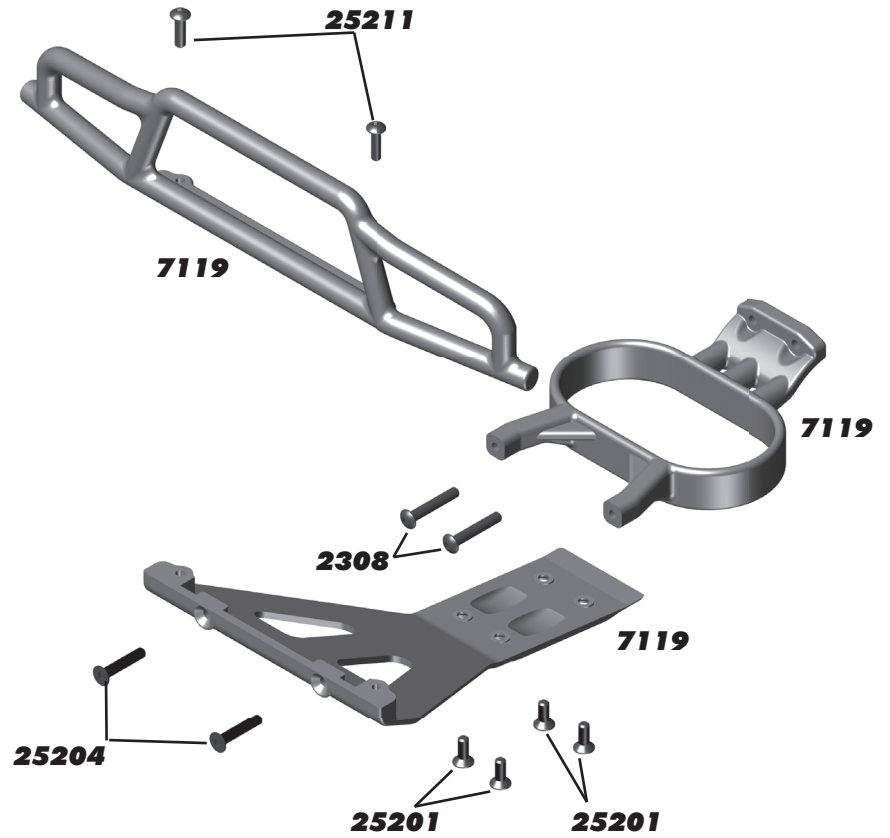

:: Rear Bumper

2308	M3x18mm BHCS	6
7120	Rear Bumper, Set	1
7121	ProLite Mud Flaps	2
25201	M3x8mm FHCS	20
25187	M3x14mm BHCS	20
89203	M3x16mm BHCS	10
89218	Washer, 3x8mm	10

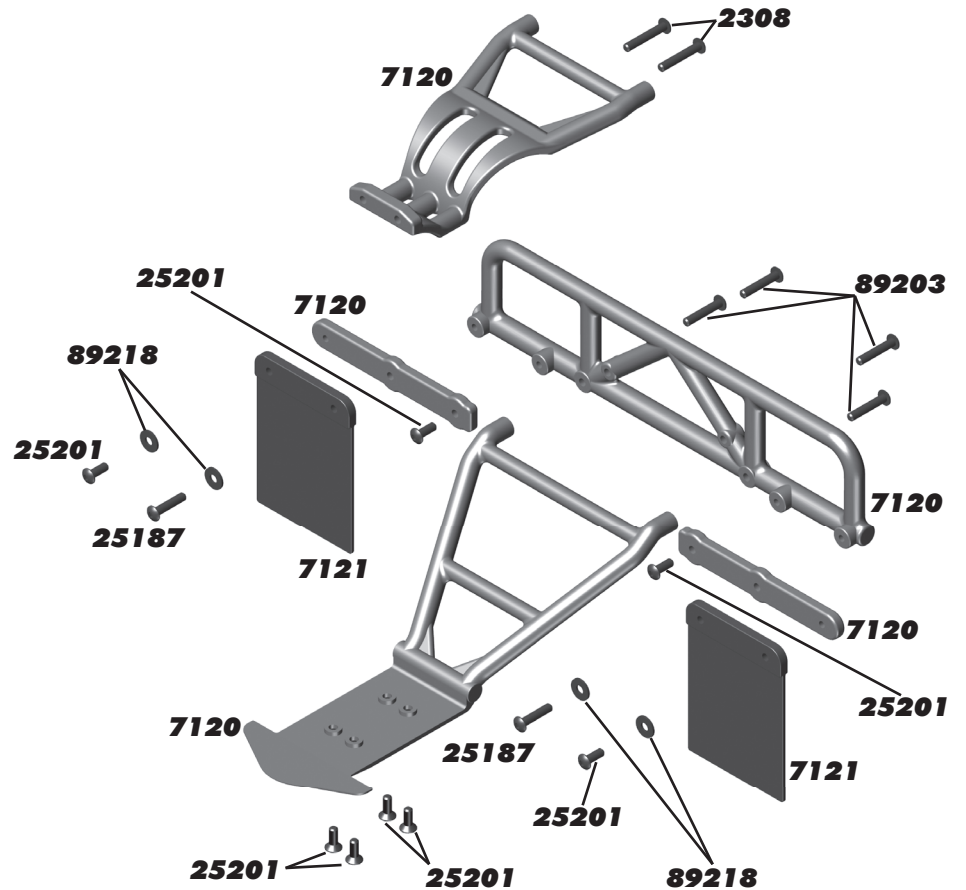

:: Front Shock Tower

7118	Body Posts (4) w/FR & RR Brackets, Set	1
7153	Shock Bushings	4
7154	Shock Tower, Front & Rear	1ea
25187	M3x14mm BHCS	20
25215	M3 Locknut, black	20
89202	M3x12mm BHCS	10
89205	M3x26mm BHCS	10
89218	Washer, 3x8mm	10

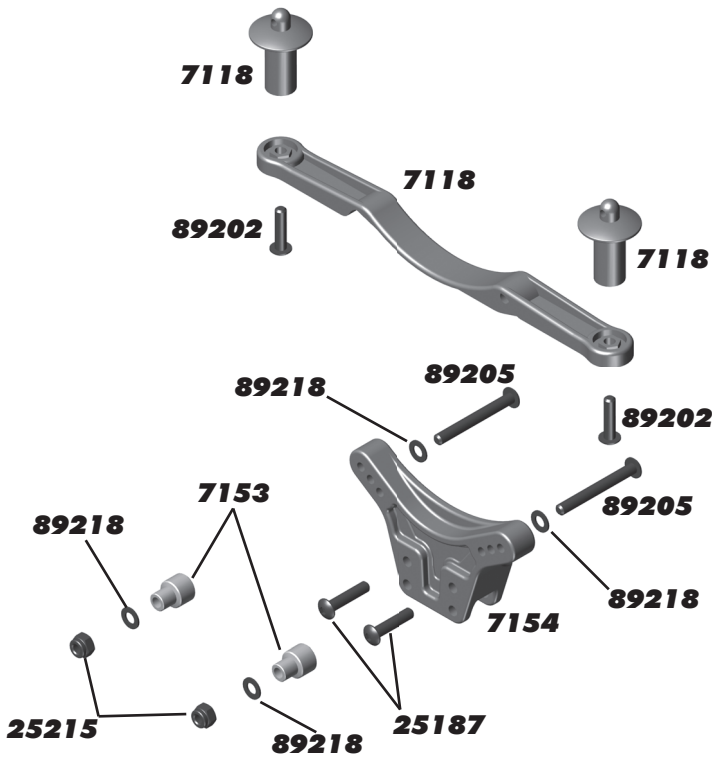

:: Rear Shock Tower

7118	Body Posts (4) w/FR & RR Brackets, Set	1
7153	Shock Bushings	4
7154	Shock Tower, Front & Rear	1ea
25187	M3x14mm BHCS	20
25215	M3 Locknut, black	20
89202	M3x12mm BHCS	10
89205	M3x26mm BHCS	10
89218	Washer, 3x8mm	10

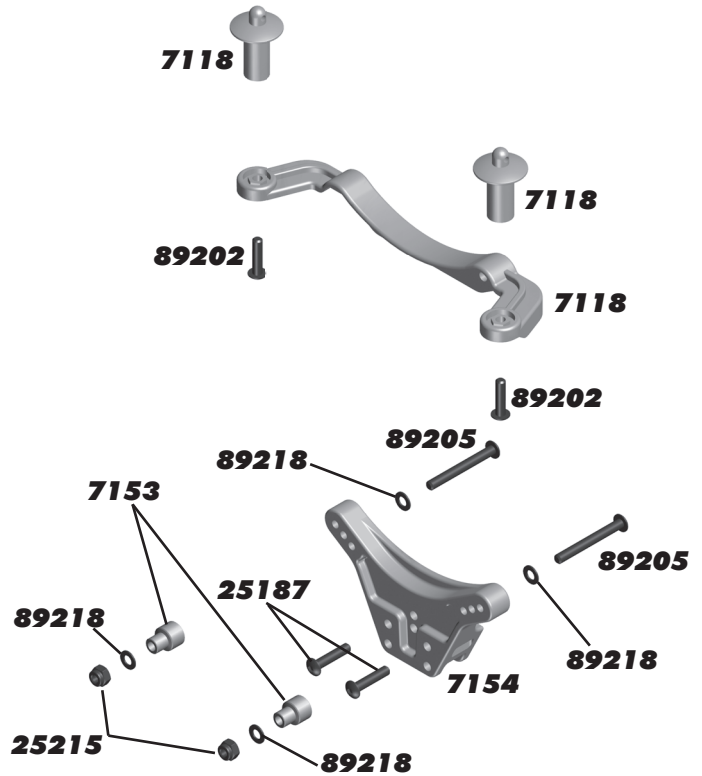

:: Motor Mount

4675	M2.5x6mm FHCS	6
7136	Motor Mount Set	1
7164	Washer, 3x6x0.5mm	10
25202	M3x10mm FHCS	20
25620	M3x10mm SHCS	20
91158	M3x4mm BHCS	10

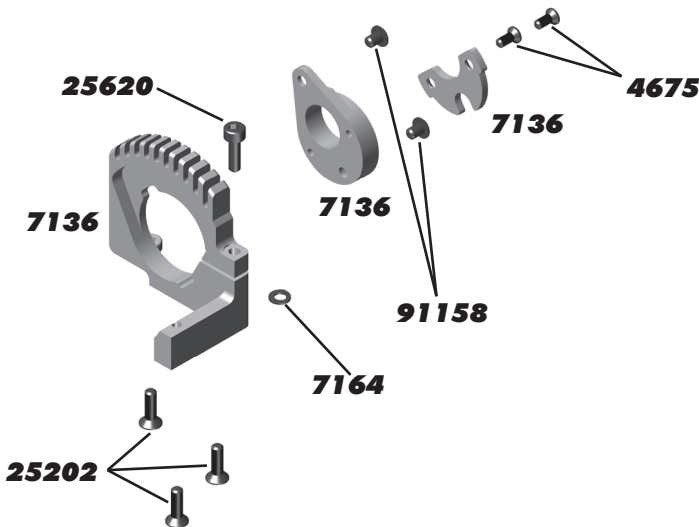

:: Turnbuckles

7159	ProLite Turnbuckle Set w/ Ball Cups	1
7160	ProLite Ball Cups	14

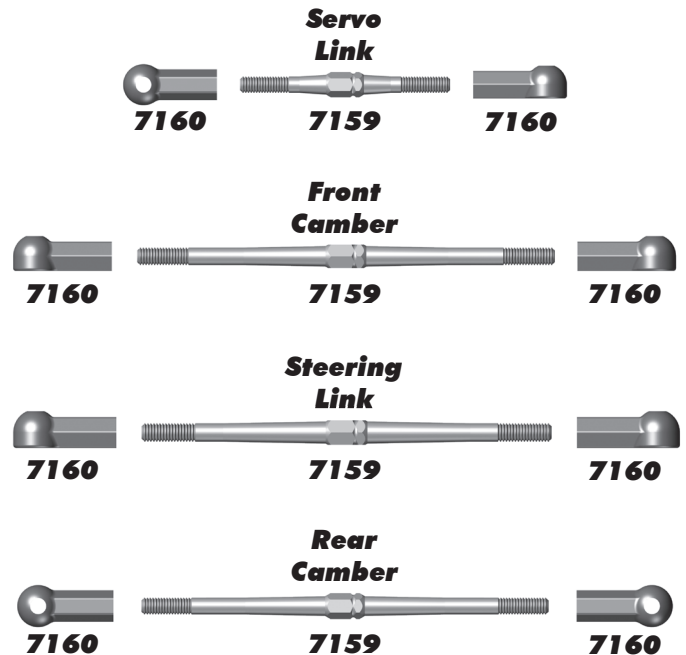

:: Chassis

2308	M3x18mm BHCS	6
7112	ProLife Chassis	1
7113	Nerf Bars	2
7114	Receiver Box w/Gaskets	1
7116	ProLife Chassis Braces	1
25187	M3x14mm BHCS	20
25202	M3x10mm FHCS	20
25211	M3x10mm BHCS	20
25215	M3 Locknut, black	20
31532	M3x8mm BHCS	6
89202	M3x12mm BHCS	10
89203	M3x16mm BHCS	10

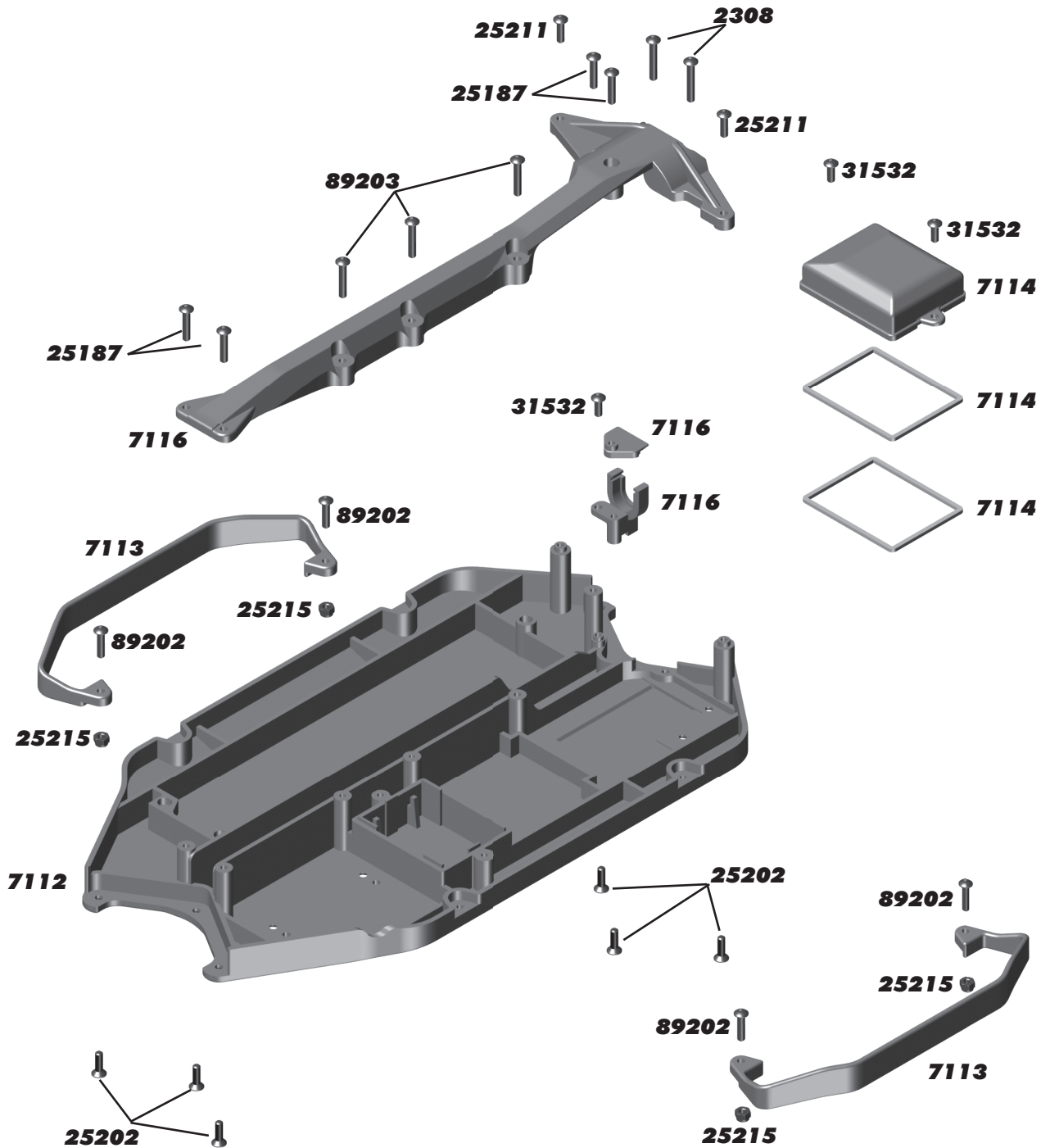

:: Slipper, Spur Gear, Pinion, and Drive Shaft

5407	Red Silicone O-Ring	8
7122	Spur Gear 32P, 47T	1
7123	Slipper Hardware, Kit	1
7124	Slipper Shaft	1
7125	Slipper Pads	2
7126	Slipper Hubs	2
7127	Drive Shaft w/ O-Rings	1
7135	Drive Pinion	1
7732	M4x4mm Set Screw	6
25225	M3x3mm Set Screw	20
25231	E-Clip, 2.5mm	20
25710	Bearing, 5x11x4	2
91162	Pinion Gear, 11T 32P (5mm shaft)	1
91163	Pinion Gear, 12T 32P (5mm shaft)	1
91164	Pinion Gear, 13T 32P (5mm shaft)	1
91165	Pinion Gear, 14T 32P (5mm shaft) Kit	1
91166	Pinion Gear, 15T 32P (5mm shaft)	1

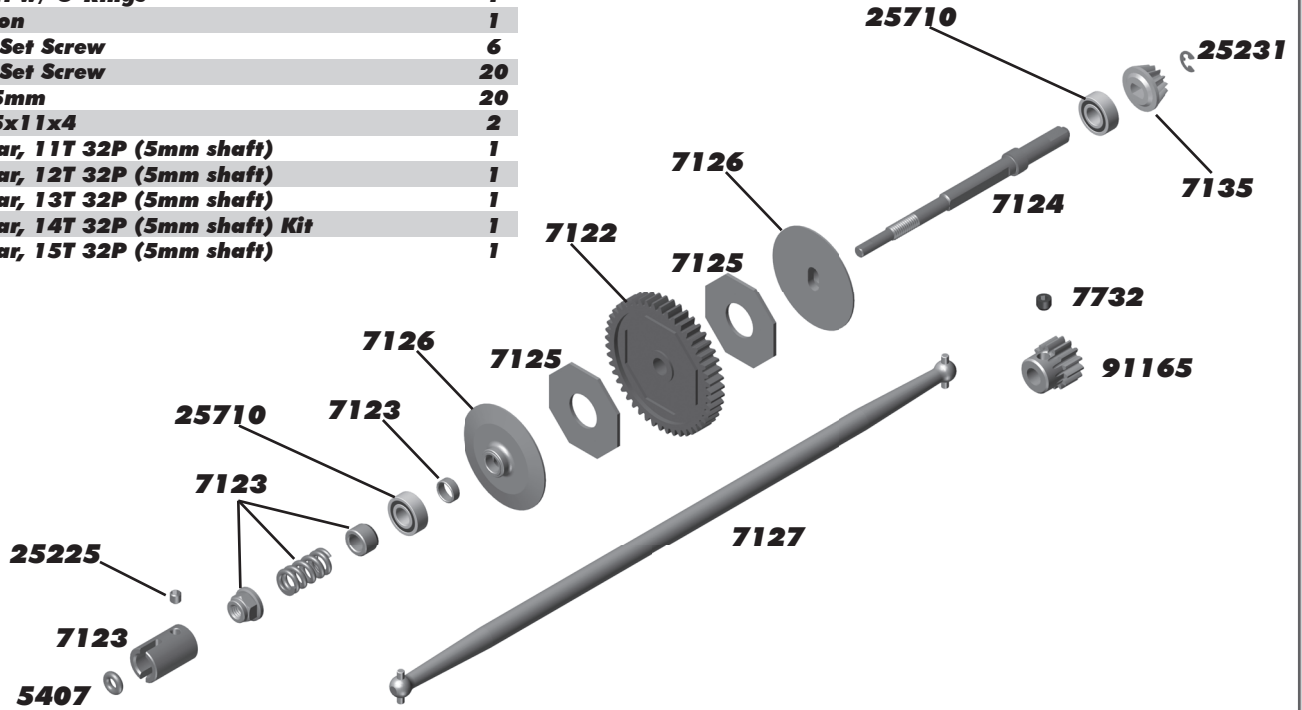

:: Wheels / Tires

9809	SC10 Tire, With Foam Insert - Kit	2
89413	Molded Tire Insert	2
91101	KMC Hex Wheels, Black (Kit)	2
91102	KMC Hex Wheels, Silver	2
91103	KMC Hex Wheels, Chrome	2
91104	KMC Hex Wheels/Tire Mounted Black	2
91105	KMC Hex Wheels/Tire Mounted Silver	2
91106	KMC Hex Wheels/Tire Mounted Chrome	2

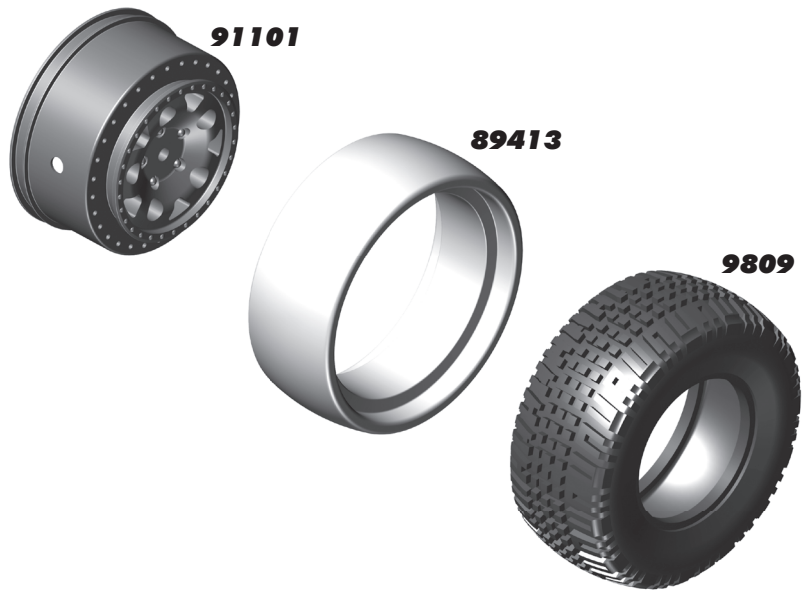

:: Body / Decals

1734	FT Body Clips, Metallic Blue, 4 long, 6 short	1
1735	FT Body Clips, Metallic Blue, long	4
1736	FT Body Clips, Metallic Blue, short	6
1737	FT Body Scissors	1
6332	Body Clips	6
7161	ProLite Body, Gray painted	1
7162	ProLite Body, Blue painted	1
7169	ProLite Decal Sheet	1
9836	SC10 Body, clear	1
9837	SC10 09' Championship Body, clear	1
9838	SC10 KMC™ Body, painted	1
9842	SC10 AE Body, painted	1
9843	SC10 Decal Sheet, KMC™	1
9844	SC10 Decal Sheet, Lucas Oil	1
9846	SC10 Decal Sheet, Pro Comp	1
9847	SC10 Decal Sheet, Team AE	1
9848	SC10 ReadyLift Body, painted	1
9849	SC10 Decal Sheet, ReadyLift	1
9850	SC10 Number Plate Decals	1
9856	SC10 09' Lucas Oil Body, painted	1
9857	SC10 '09 Decals, Lucas Oil	1
9858	SC10 09' Pro Comp Body, painted	1
9859	SC10 '09 Decals, Pro Comp	1
9860	SC10 09' Speed Technologies Body, painted	1
9861	SC10 '09 Decals, Speed Technologies	1
9862	SC10 09' Rockstar-Makita Body, painted	1
9863	SC10 '09 Decals, Rockstar-Makita	1
9874	SC10 09' Monster Energy Body, painted	1
9875	SC10 Monster Energy Decals	1
9876	SC10 Contender Body, clear	1
9886	SC10 09' Slick Mist Body, painted	1
9887	SC10 Slick Mist Body Decal Sheet	1
9896	SC10 09' Hart and Huntington Body, painted	1
9897	'09 Hart and Huntington Decal Sheet	1

:: Factory Team and Option Parts

9787	FT Chassis Protective Sheet	1
31286	FT Ballstud Washer, aluminum (2mm and 1mm)	4ea
31550	FT M3 Locknut, blue aluminum	6
91160	Body Clip, 1.3mm thick	10
91171	4x4 Aluminum Wheel Hexes	4

:: XP Electronics

29107	XP DS1903/S1903 Metal Gear Set	1
29125	S1903MG Servo	1
29133	XP DS1903 Digital Servo	1
29134	XP DS1903MG Digital Servo	1
29138	XP SC500-BL Brushless ESC	1
29139	XP SC900-BL Brushless ESC	1
29140	XP SC200 Brushed ESC	1
29141	XP SC450-BL Brushless ESC	1
29142	XP ESC Fan Option	1
29143	XP SC700-BL Brushless ESC	1
29144	XP SC1200-BL Brushless ESC	1
29166	XP DS1313 Digital Servo	1
29167	XP DS1015 Digital Servo	1
29168	XP DS1510MG Digital Servo	1
29209	Gear Set, DS1313	1
29210	Gear Set, DS1015	1
29211	Servo Case, DS1313/DS1015	1
29212	Accessory Pack, DS1313/DS1015	1
29214	TRS403-SSi 2.4GHz 4Ch Receiver	1
29215	XP2G 2.4GHz Radio System	1
29216	XP3G 2.4GHz Radio System	1
29250	XP DS1505 Digital Servo	1
29251	XP DS1505MG Digital Servo	1
29252	XP DS1505 Metal Gear Set	1
29253	XP DS1510 Metal Gear Set	1

:: Reedy Accessories

247	Sonic 540 Mach 2 Sensor w/bearing	1
248	Sonic 540 Mach 2 Steel Bearing Set	1
249	Sonic 540 Mach 2 Ceramic Bearing Set	1
250	Sonic 540 Mach 2 Insulator Set	1
604	526-S AC/DC 2S-6S LiPo/LiFe Charger	1
606	Charge Harness 2S Saddle Pack 4mm	1
607	Charge Harness 2S Standard Pack 4mm	1
609	TAM to DEANS® charge adapter	1
610	447-S AC/DC NiMH Peak Charger	1
651	Battery Bars (8)	1
654	4.0mm plugs (2M, 2F)	1
655	4.0mm plugs (2M, 10F)	1
656	4.0mm plugs (10F)	1
658	4.0mm plugs (10M)	1
659	4.0mm plugs (30M)	1
660	3.5mm plugs (3M, 3F)	1
661	3.5mm plugs (10F)	1
663	3.5mm plugs (10M)	1
664	3.5mm plugs (30M)	1
716	Reedy 09 Decal Set	1
962	Sonic 540 Case Screws (3 pcs.)	1
974	540-SL/550-SL Steel Bearing Set	1
975	540-SL/550-SL Ceramic Bearing Set	1
978	Flat Sensor Wire 70mm	1
979	Flat Sensor Wire 110mm	1
980	Flat Sensor Wire 150mm	1
981	Flat Sensor Wire 200mm	1
982	Flat Sensor Wire 270mm	1
992	Sonic 540 Rotor Spacers	1

:: Reedy Batteries

302	AA Alkaline 1.5V (4)	1
309	LiPo 65C 7000mAh 7.4V	1
602	LiPo 65C 4100mAh 7.4V Shorty	1
637	LiPo TX Battery - M11X 2500mAh 7.4V	1
681	Wolfpack 2400mAh 7.2V w/DEANS® connector	1
682	Wolfpack 3000mAh 7.2V w/DEANS® connector	1
683	Wolfpack 3600mAh 7.2V w/DEANS® connector	1
684	Wolfpack 4200mAh 7.2V w/DEANS® connector	1
689	R-Power 1700mAh 7.2V w/TAM connector	1
693	Wolfpack 2400mAh 7.2V w/TAM connector	1
694	Wolfpack 3000mAh 7.2V w/TAM connector	1
695	Wolfpack 3600mAh 7.2V w/TAM connector	1
700	Wolfpack 4200mAh 7.2V w/TAM connector	1
730	Wolfpack LiPo 3000mAh 7.4V 25C w/DEANS®	1
731	Wolfpack LiPo 3300mAh 7.4V 35C w/DEANS®	1
732	Wolfpack LiPo 3400mAh 7.4V 35C w/DEANS®	1
734	Wolfpack LiPo 6500mAh 7.4V 25C w/DEANS®	1
735	Wolfpack LiPo 3900mAh 11.1V 35C w/DEANS®	1
736	Wolfpack LiPo 5000mAh 7.4V 25C	1
738	Wolfpack LiPo 3800mAh 7.4V 25C Shorty	1

:: Reedy Motors and ESC's

231	Sonic 540 Mach 2 21.5 Competition Brushless Motor	1
232	Sonic 540 Mach 2 17.5 Competition Brushless Motor	1
233	Sonic 540 Mach 2 13.5 Competition Brushless Motor	1
234	Sonic 540 Mach 2 10.5 Competition Brushless Motor	1
235	Sonic 540 Mach 2 9.5 Competition Brushless Motor	1
236	Sonic 540 Mach 2 8.5 Competition Brushless Motor	1
237	Sonic 540 Mach 2 8.0 Competition Brushless Motor	1
238	Sonic 540 Mach 2 7.5 Competition Brushless Motor	1
239	Sonic 540 Mach 2 7.0 Competition Brushless Motor	1
240	Sonic 540 Mach 2 6.5 Competition Brushless Motor	1
241	Sonic 540 Mach 2 6.0 Competition Brushless Motor	1
242	Sonic 540 Mach 2 5.5 Competition Brushless Motor	1
243	Sonic 540 Mach 2 5.0 Competition Brushless Motor	1
244	Sonic 540 Mach 2 4.5 Competition Brushless Motor	1
245	Sonic 540 Mach 2 4.0 Competition Brushless Motor	1
246	Sonic 540 Mach 2 3.5 Competition Brushless Motor	1
908	Replacement Rotor 540-SL	1
920	540-SL Brushless Motor 3300kV	1
921	540-SL Brushless Motor 3900kV	1
922	540-SL Brushless Motor 4900kV	1
923	540-SL Brushless Motor 6100kV	1
954	Sonic 540 Stock Rotor 12.3 x 24.2 (7.25)	1
955	Sonic 540 Stock Rotor 12.3 x 25.0 (7.25)	1
956	Sonic 540 Stock Rotor 12.5 x 25.0 (7.25)	1
957	Sonic 540 Modified Rotor 12.2 x 25.0 (5.0)	1
958	Sonic 540 Modified Rotor 12.5 x 25.0 (5.0)	1
965	Reedy 540-SL 3300kV/XP SC700-BL ESC Combo	1
966	Reedy 540-SL 3900kV/XP SC700-BL ESC Combo	1
967	Reedy 540-SL 4900kV/XP SC700-BL ESC Combo	1
983	Reedy 540-SL 3300kV/XP SC1200-BL ESC Combo	1
984	Reedy 540-SL 3900kV/XP SC1200-BL ESC Combo	1
985	Reedy 540-SL 4900kV/XP SC1200-BL ESC Combo	1
986	Reedy 540-SL 6100kV/XP SC1200-BL ESC Combo	1
987	Sonic 540 Modified Rotor 13.0 x 25.0 (5.0)	1

:: 1/18 Kits and RTR's

20103	RC18B2 - RC18T2 Team Kit	1
20121	SC18 RTR Brushless (ready-to-run)	1

:: 1/12, 1/10 Kits and RTR's

2042	Nitro TC3 RTR Plus (ready-to-run)	1
4020	FT 12R5.2 Kit	1
6001	RC10 Classic Kit	1
7025	FT RC10T4.2 Kit	1
7029	SC10 Associated/RC10.com Truck RTR (ready-to-run)	1
7030	SC10 KMC Wheels Race Truck RTR (ready-to-run)	1
7038	FT SC10.2 Kit	1
7039	RC10T4.2 RS RTR 2.4GHz Brushless (ready-to-run)	1
7046	SC10 RS RTR, Lucas Oil (ready-to-run)	1
7048	SC10 RS RTR, Pro Comp (ready-to-run)	1
7049	SC10 RS RTR, Rockstar/Makita (ready-to-run)	1
7050	SC10 RS RTR, Hart and Huntington (ready-to-run)	1
7093	SC10GT RTR (ready-to-run)	1
8020	FT RC10R5 Kit	1
8022	FT RC10R5.1 Kit	1
9040	FT RC10B4.1 Worlds Kit	1
9041	FT RC10B4.2 Kit	1
9042	RC10B4.2 RS RTR 2.4GHz Brushless (ready-to-run)	1
9050	SC10B RS RTR (ready-to-run)	1
9062	FT B44.2 4WD Buggy Kit	1
30101	TC4 Club Racer 4WD Touring Car Race Roller	1
30108	FT TC6.1 WC 4WD Touring Car Kit	1
90005	SC10 4x4 Lucas Oil RTR (ready-to-run)	1
90006	SC10 4x4 Pro Comp RTR (ready-to-run)	1
90010	SC10 4x4 FT Kit	1

:: Qualifier Series Vehicles

7052	Pro Lite 4x4 RTR, 1/10 Scale (ready-to-run)	1
20111	Rival Mini Monster Truck 1/18 Scale (ready-to-run)	1
20119	APEX Mini Touring RTR	1
20510	RIVAL Electric Monster Truck RTR, 1/8 Scale (ready-to-run)	1
30112	APEX Touring V-Type, 1/10 Scale (ready-to-run)	1

:: 1/8 Kits and RTR's

20501	MGT 4.60 SE RTR (ready-to-run)	1
20502	MGT 8.0 Nitro RTR (ready-to-run)	1
20503	Limited Edition MGT 4.60 Nitro RTR, w/flag body (ready-to-run)	1
20504	Limited Edition MGT 8.0 Nitro RTR, w/flag body (ready-to-run)	1
80906	RC8.2 Nitro Buggy FT Kit	1
80907	RC8.2e Electric Buggy FT Kit	1
80908	RC8.2e Electric Buggy RTR (ready-to-run)	1
80909	RC8.2RS Nitro Buggy RTR (ready-to-run)	1
80912	RC8T Championship Edition	1
80933	SC8.2e Short Course Race Truck, Rockstar/Makita Electric RTR (ready-to-run)	1
80934	SC8.2e Short Course Race Truck, Slick Mist Electric RTR (ready-to-run)	1

:: Hardware - 1:1 Scale View

Cap Head (shcs)

 **3x10mm (25620)**







Set screw

 **3x3mm (25225)**
 **4x3mm (25223)**
 **4x4mm (7732)**







Nuts (lock/plain)

 **M3 Locknut (25215)**
M3 Alum. Locknut, Blue (31550)
 **M4 Locknut w/Flange & Knurl (91148)**
FT M4 Locknuts w/Flange, Blue (31551)



Shims and Washers

 **Nylon Spacer .030 (4187)**
 **Arm Shim (7158)**
 **3x6mm Washer (7164)**
 **3x8mm Thin Washer (89218)**
 **6x12mm Washer (7165)**
 **Pro Lite Diff Shim (7133)**







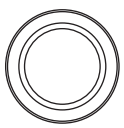

Flat Head (fhcs)

 **2.5x6mm (4675)**
 **2.5x10mm (31350)**
 **3x8mm (25201)**
 **3x10mm (25202)**
 **3x16mm (89224)**
 **3x18mm (89209)**
 **3x22mm (89455)**

Ball Bearings

 **5x8mm (31400)**
 **5x11x4mm, qty 2 (25710)**
qty 4 (25618)
 **10x15x4mm (25616)**

Button Head (bhcs)

 **2.5x6mm (31520)**
 **3x4mm(91158)**
 **3x8mm (31532)**
 **3x10mm (25211)**
 **3x12mm (89202)**
 **3x14mm (25187)**
 **3x16mm (89203)**
 **3x18mm (2308)**
 **3x26mm (89205)**

Button Head (bhps)

 **2x4mm, flanged (7168)**
 **Tap Screw (7167)**

Ballstuds

 **Ballstud, short (7163)**
 **Ballstud, long (7163)**

:: Apparel

SP36**	Reedy 09' Black T-Shirt (M, XL, 2XL)	1
SP37**	Reedy 2012 T-shirt - Black (S, M, L, XL, 2XL, 3XL)	1
SP38	Reedy Trucker Hat	1
SP39	Reedy Patch	1
SP66**	Stencil Blue T-Shirt (S, M, L, XL, 2-6XL)	1
SP67**	AE Stencil Gray Sweatshirt (S, M, L, XL, 2XL, 3XL)	1
SP68**	AE Stencil Blue T-Shirt (M, L, XL)	1
SP69**	AE 26 Time World Championship T-Shirt, Black (S, M, L, XL, 2XL, 3XL)	1
SP70**	Associated Windbreaker (XL)	1
SP71**	Associated Winter Jacket (M, L, XL)	1
SP73**	AE Long Sleeve T-Shirt (S, M, L, XL, 2XL)	1
SP74**	AE White T-Shirt (S, M, L, XL, 2XL, 3XL, 4XL)	1
SP75**	AE Blue T-Shirt (S, M, L, XL, 2XL, 4XL, 6XL)	1
SP76**	AE Black T-Shirt (S, M, L, XL, 2XL, 3XL)	1
SP77**	AE 2012 T-Shirt, Blue (S, M, L, XL, 2XL, 3XL)	1
SP78**	AE 2012 T-Shirt, White (S, M, L, XL, 2XL, 3XL)	1
SP79**	AE 2012 T-Shirt, Black (S, M, L, XL, 2XL, 3XL)	1
SP84**	Reedy 3D T-Shirt, Black (S, M, L, XL, 2XL, 3XL)	1
SP85**	Reedy Zip Hoodie, Black (S, M, L, XL, 2XL, 3XL)	1
SP86**	Reedy Girl's 3D T-Shirt, Black (S, M, L, XL)	1
SP87**	AE 2013 Zip Hoodie (S, M, L, XL, 2XL, 3XL)	1
SP411S	AE Hat 11' Flat Bill Black S/M	1
SP411L	AE Hat 11' Flat Bill Black L/XL	1
SP413S	26 Time World Championship Hat S/M	1
SP413L	26 Time World Championship Hat L/XL	1
SP416	Associated Car Carrier Bag, Medium	1
SP417	1/10 FT Motor Bag	1
SP418	Factory Team 1/10 Car Carrier Bag	1
SP420**	AE Pit Gloves (L, XL)	Pr.
SP421S	AE 2012 Hat, Black, Flat Bill, S/M	1
SP421L	AE 2012 Hat, Black, Flat Bill, L/XL	1
SP422S	AE 2012 Hat, Black, Curved Bill, S/M	1
SP422L	AE 2012 Hat, Black, Curved Bill, L/XL	1
SP423S	AE 2012 Hat, White, Flat Bill, S/M	1
SP423L	AE 2012 Hat, White, Flat Bill, L/XL	1
SP424S	AE 2012 Hat, White, Curved Bill, S/M	1
SP424L	AE 2012 Hat, White, Curved Bill, L/XL	1
715	Reedy 2009 Track Banner	1
110684	Team Associated Track Banner	1

:: RePlay Cameras

RP001	Replay XD1080 Complete Camera System	1
RP002	Replay XD720 Complete Camera System	1
RP021	Replay XD1080 Lens Bezel Kit	1
RP022	Replay XD1080 Clear Lens Cover	1
RP023	Replay XD1080 Lens Bezel & Rear Cap O-Ring	1
RP029	Replay XD1080 HDMI to Mini-HDMI	1
RP030	Replay XD1080 Mini 8-pin USB Charge Data Cable	1
RP032	USB DC Car Charger 1A Stubby	1
RP033	USB DC Car Charger 500mAh	1
RP034	Micro SDHC USB Reader	1
RP036	3M VHB 4991 Mount Adhesive for SnapTray	1
RP038	3M VHB 5962 Mount Adhesive for SnapTray	1
RP041	Replay XD Suction Cup Arm Mini Clamp	1
RP042	Replay XD Suction Cup Short Arm Base	1
RP043	Replay XD Skateboard Mount	1
RP044	Replay XD VHB SnapTray, Convex	1
RP045	Replay XD VHB SnapTray, Flat	1
RP046	Au Plug for Universal DC Wall Charger	1
RP047	Eu Plug for Universal DC Wall Charger	1
RP048	Uk Plug for Universal DC Wall Charger	1
RP049	Universal USB DC Wall Charger 1A	1
RP054	Replay ReView Field Monitor	1

:: Tools

1112	FT 4mm Turnbuckle Wrench	1
1449	FT Off Road Ride Height Gauge	1
1541	FT Hex Driver Set, (7 pcs)	1
1542	FT .050" Silver Hex Driver	1
1543	FT 1/16" Black Hex Driver	1
1544	FT 1.5mm Purple Hex Driver	1
1545	FT 5/64" Blue Hex Driver	1
1546	FT 3/32" Gold Hex Driver	1
1547	FT 2.5mm Green Hex Driver	1
1548	FT 3mm Red Hex Driver	1
1551	FT Screwdriver Set	1
1553	FT Phillips Silver Screwdriver	1
1554	FT Silver Spring Hook Tool	1
1561	FT Nut Driver Set, (6 pcs)	1
1562	FT 3/16" Black Nut Driver	1
1563	FT 1/4" Red Nut Driver	1
1564	FT 5.5mm Red Nut Driver	1
1565	FT 11/32" Green Nut Driver	1
1566	FT 7.0mm Silver Nut Driver	1
1567	FT 8mm Gold Nut Driver	1
1589	FT 5/64" Blue Ball Hex Driver	1
1590	FT 3/32" Gold Ball Hex Driver	1
1592	FT Ball Hex Driver Set, (3 pcs)	1
1655	FT 8-Piece 1/4" Hex Drive Set	1
1656	FT 1/4" Hex Drive Handle, without tips	1
1657	FT 1/4" Hex Drive .050" Tip	1
1658	FT 1/4" Hex Drive 1/16" Tip	1
1659	FT 1/4" Hex Drive 5/64" - 2.0mm Tip	1
1660	FT 1/4" Hex Drive 3/32" Tip	1
1661	FT 1/4" Hex Drive 1.5mm Tip	1
1662	FT 1/4" Hex Drive 2.5mm Tip	1
1663	FT 1/4" Hex Drive 3/16" Nut Driver Tip	1
1664	FT 1/4" Hex Drive 1/4" Nut Driver Tip	1
1665	FT 1/4" Hex Drive 11/32" Nut Driver Tip	1
1666	FT 1/4" Hex Drive 5.5mm Nut Driver Tip	1
1667	FT 1/4" Hex Drive 7.0mm Nut Driver Tip	1
1668	FT 1/4" Hex Drive 8.0mm Nut Driver Tip	1
1669	FT 1/4" Hex Drive 5/64" - 2.0mm Ball End Tip	1
1670	FT 1/4" Hex Drive 3/32" Ball End Tip	1
1671	FT 1/4" Hex Drive Standard Screwdriver Tip	1
1672	FT 1/4" Hex Drive Phillips Screwdriver Tip	1
1673	FT 1/4" Hex Drive 2.5mm Ball End Tip	1
1674	FT 1/4" 5 Piece Power Tool Tips Set (5/64-2.0mm, 1.5mm, 2.5mm, 5/64"- 2.0mm ball, 2.5mm ball)	1
1719	FT Camber + Track Width Tool	1
1737	FT Body Scissors	1
3718	12 Inch Nylon Wire Ties	12
3719	6 Inch Nylon Wire Ties	12
3720	8 Inch Nylon Wire Ties	12
3987	FT Droop Gauge	1
6429	Shock Building Tool	1
6956	Molded Tools, Set	1
7494	V2 Stamped Multi-Tool	1
7709	4 Inch Nylon Wire Ties	12

Associated Electrics, Inc.
26021 Commercentre Drive
Lake Forest, CA 92630-8853 USA
<http://www.TeamAssociated.com>
<http://www.RC10.com>
<http://twitter/TeamAssociated>
<http://bit.ly/AEonFacebook>

call: (949) 544-7500

fax: (949) 544-7501

Check out the following web sites for all of our electric kits, current products, new releases, setup help, tips, and racing info!

www.TeamAssociated.com - www.RC10.com

:: Trouble Shooting

Description	Problem	Solution
No Power	Battery is discharged..... Battery not plugged in..... No light on speed control.... Receiver LED remains red.	Charge battery. Plug in battery. Reset speed control using your instruction manual. Re-bind transmitter to the receiver.
No Throttle	Motor not plugged in..... Speed control out of adjustment. Motor failure.....	Plug in motor. Reset speed control using your instruction manual. Replace motor.
No Steering	Servo not plugged in..... Locked up steering linkage. Servo failure.....	Plug servo in. Free up steering linkage. Replace servo.
Throttle	Goes backwards when you pull the trigger, or forward when pushing brakes / reverse.	Switch any two motor wires. Check throttle reversing switches on transmitter. Reset speed control.
Steering	Goes right when turning..... the wheel left (or left when turned right.)	Check steering reversing switches on transmitter.
Vehicle is glitching	Vehicle has a problem on.... power:	Check for loose wires or check for or dead radio batteries. Radio interference.
Reverse	No reverse or brakes.....	Check that reverse mode has not been turned off. Refer to speed control instructions. Reset speed control, or send in for repair.
Vehicle dies or slows	Speed control overheats.... Motor overheats..... Gear mesh set too tight..... LiPo mode engages.....	Let speed control cool off. Check gear, gear mesh, or bind in driveline. Let motor cool and check recommended gearing for motor type. Reset gear mesh (see instruction manual). LiPo mode on the ESC has engaged, recharge your batteries. (If running NiMH battery, turn off LiPo mode)