

ASSOCIATED RC10

ASSEMBLY AND OPERATING INSTRUCTIONS

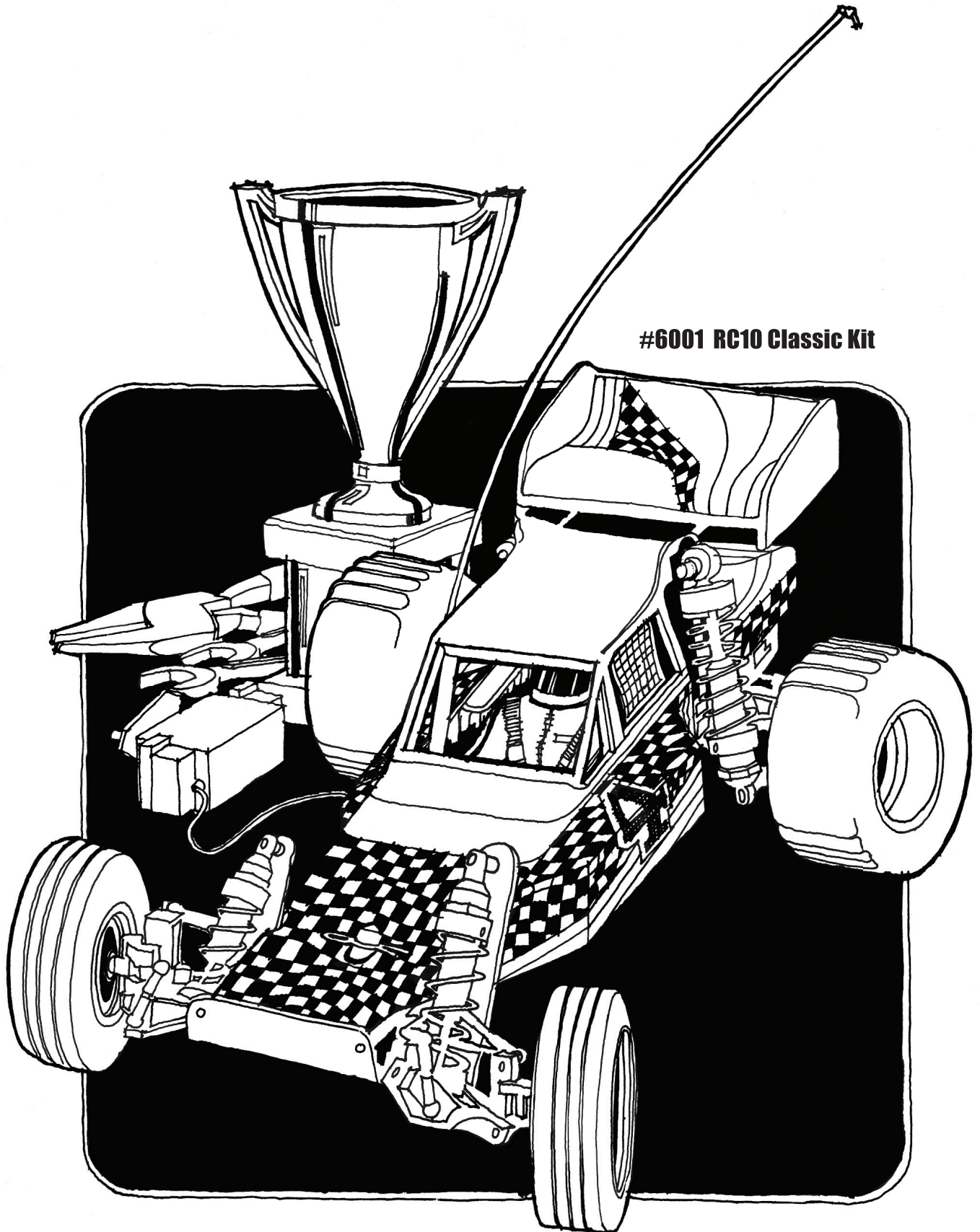

#6001 RC10 Classic Kit

:: Introduction

Thank you for purchasing this Team Associated product. This assembly manual contains instructions and tips for building and maintaining your new RC10 Classic. Please take a moment to read through this manual to help familiarize yourself with these steps.

We are continually changing and improving our designs; therefore, actual parts may appear slightly different than in the illustrations. New parts will be noted on supplementary sheets located in the appropriate parts bags. Check each bag for these sheets before you start to build.

:: KIT Features

Features in the RC10 Classic:

- Authentic replica of the RC10 Buggy Kit originally released in 1984
- Gold anodized 6061-T6 aluminum monocoque tub chassis
- Fully adjustable four wheel independent suspension
- Long travel, fluid filled gold anodized aluminum coil over shocks
- Low profile sealed six-gear transmission
- VariLok adjustable ball differential
- Exceptional ground clearance with low center of gravity
- Pro-Line front and rear tires with modular racing wheels
- Clear ProTech body with driver figure and wing
- Fiberglass shock towers
- Oilite bushings throughout
- Fits 6-cell NiMh and 2S LiPo battery packs

:: Additional

Your new RC10 Classic comes as a kit. There are some items you will need to complete your kit (refer to catalog for suggestions):

- R/C two channel surface frequency radio system
- Electronic Speed Control (ESC)
- Steering Servo and Servo Horn (AE # 9180, 89007)
- 2S, 7.4V Lipo stick battery or 7.2V NiMH battery
- Peak detection battery charger
- #2 Bit Type Phillips Screw Driver
- Polycarbonate specific paint
- Pinion gear, size to be determined by type and wind of motor you use
- R/C Electric Motor
- Retaining Ring Pliers
- Thread Lock (AE # 1596)

Tools included:

- Allen wrenches (AE # 6950)
(.050", 1/16", 3/32", 5/64")
- Allen wrench .035"
- Molded tools (AE # 6956)
- Camber gauge (AE # 1719)
- Shock building tool (AE # 6429)

:: Other Helpful Items

- Silicone Shock Fluid (Refer to catalog for complete listings)
- Body Scissors (AE # 1737)
- FT Hex Wrenches (AE # 1655)
- Soldering Iron
- Reamer / Hole Punch
- Needle Nose Pliers
- Calipers or a Precision Ruler
- Tire Adhesive (AE # 1597)
- Wire Cutters
- Multi Tool (AE # 7494)
- Green Slime shock lube (AE # 1105)
- Hobby Knife

Associated Electrics, Inc.
26021 Commercentre Dr.
Lake Forest, CA 92630



Customer Service
Tel: 949.544.7500
Fax: 949.544.7501

:: Table of Contents

1..... Cover	15Chassis Build (Bag H)
2..... Introduction	15 - 17..... Electronics Build (Bag I)
3..... Table of Contents	17 - 19..... Wheels, Tires and Body Install (Bag J)
4.....Nose Plate / Steering Build (Bag A-AA)	20 - 21..... Tuning Tips
4 - 5..... Front Suspension Build (Bag B)	22 - 30.....Catalog
6 - 9.....Transmission Build (Bag C-CC)	31..... Setup Sheet "Kit Setup"
9 - 10.....Rear Bulkhead Build (Bag D-DD)	32..... 1:1 Hardware "Fold Out"
10 - 11.....Rear Suspension Build (Bag E-EE)	33..... Setup Sheet "Blank"
11 - 12.....Turnbuckles Build (Bag F)	34..... Back Cover
12 - 14.....Shocks Build (Bag G-GG)	

:: Notes

This symbol indicates a special note or instruction in the manual.



There is a 1:1 hardware foldout page in the back of the manual. To check the size of a part, line up your hardware with the correct drawing until you find the exact size. Each part in the foldout has a number assigned to it for ordering replacement parts.

Associated Electrics, Inc.
26021 Commercentre Dr.
Lake Forest, CA 92630



Customer Service
Tel: 949.544.7500
Fax: 949.544.7501

<http://www.TeamAssociated.com> • <http://www.RC10.com> • http://twitter.com/Team_Associated • <http://bit.ly/AEonFacebook>

:: Nose Plate / Steering Build - Bag A-AA - Step 1

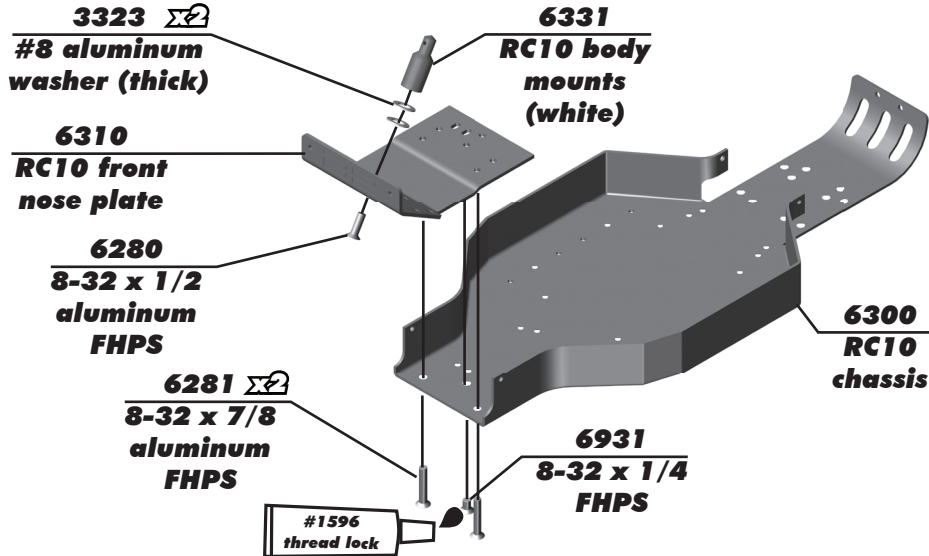

:: Nose Plate / Steering Build - Bag A-AA - Step 2

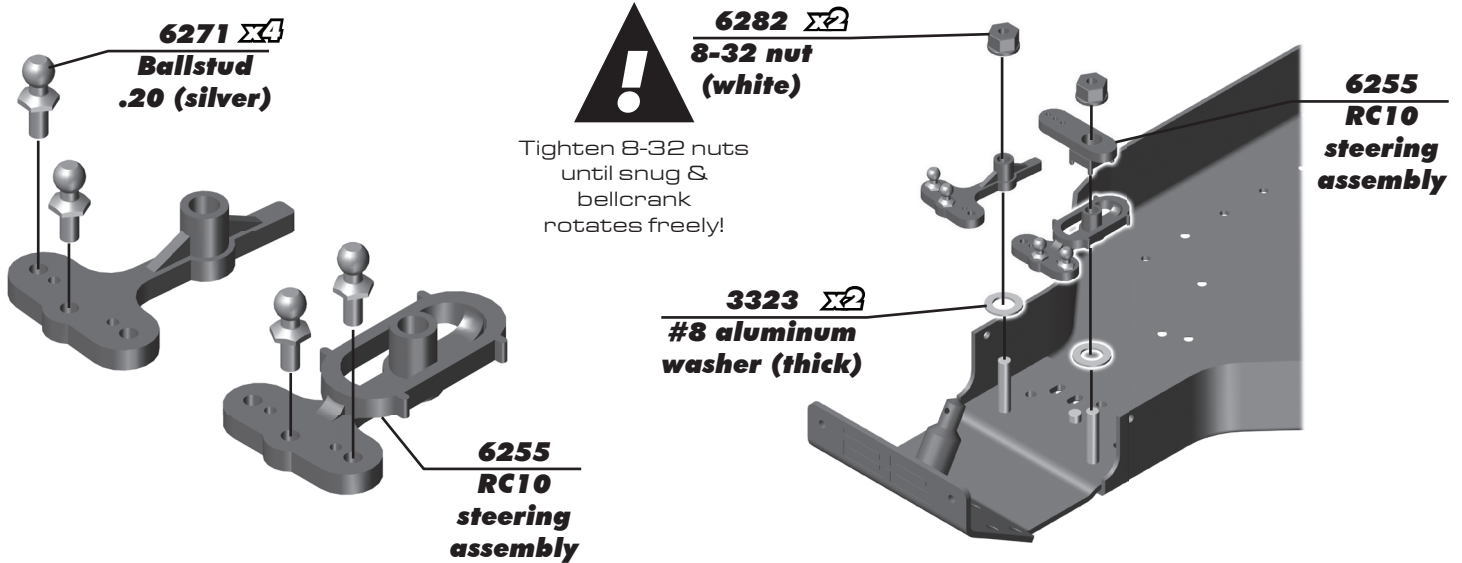

:: Front Suspension Build - Bag B - Step 1

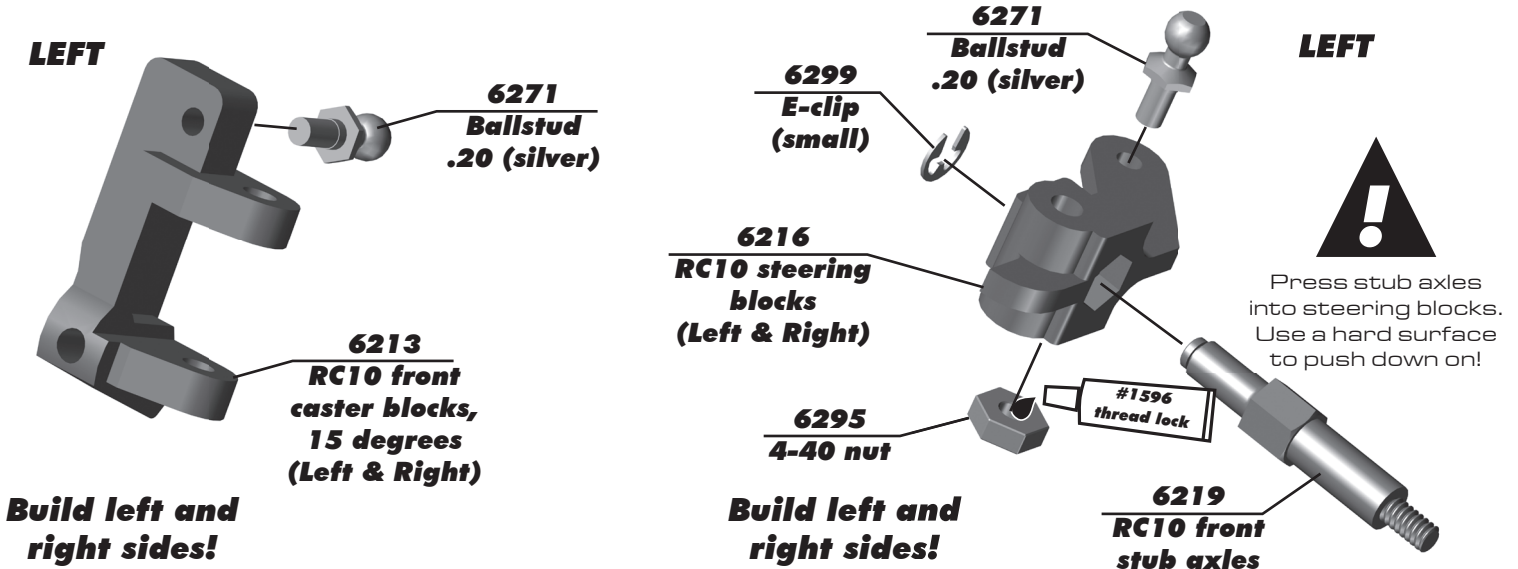

:: Front Suspension Build - Bag B - Step 2

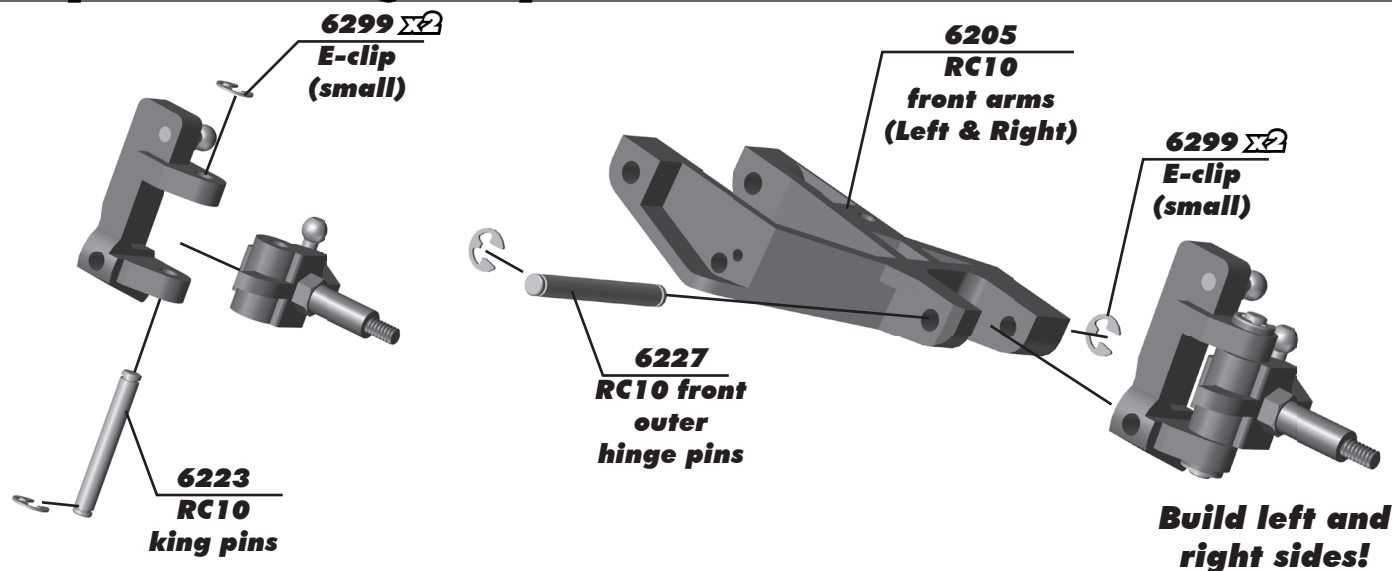

:: Front Suspension Build - Bag B - Step 3

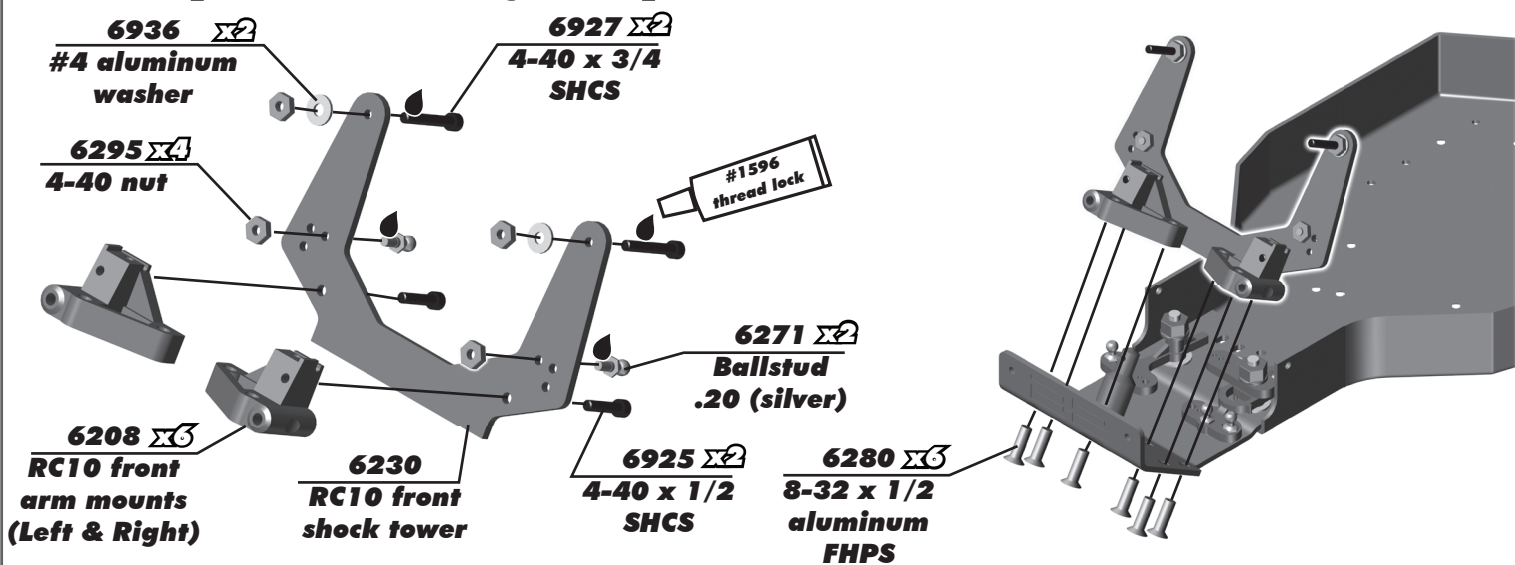

:: Front Suspension Build - Bag B - Step 4

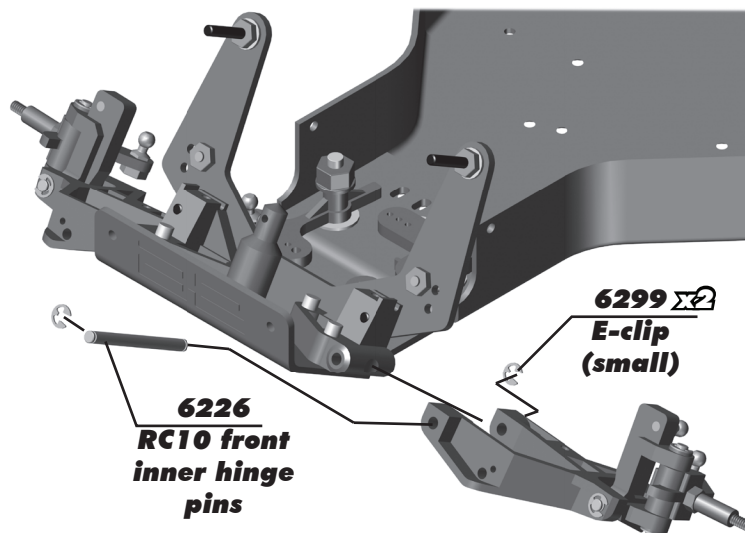

:: Transmission Build - Bag C-CC - Step 1

6604
Drive gear
pivot pin

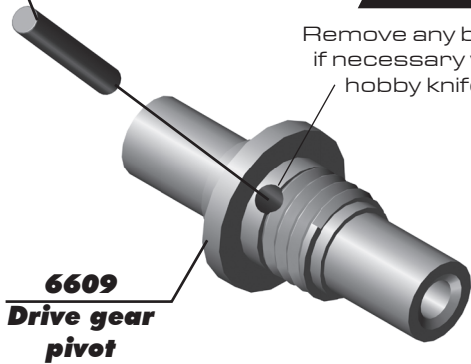

Remove any burrs
if necessary with
hobby knife!

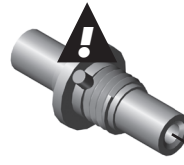

Key drive gear pin
into slot on spine
plate!

6609
Drive gear
pivot

6611
RC10
spine
plate

6609
Drive gear
pivot nut



:: Transmission Build - Bag C-CC - Step 2

6610
RC10 idler
gear pivot

NOTE: Install washer [1]
before bowed e-clip [2]

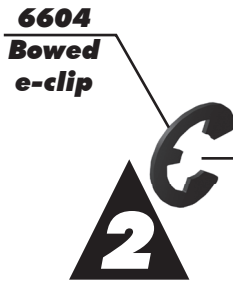
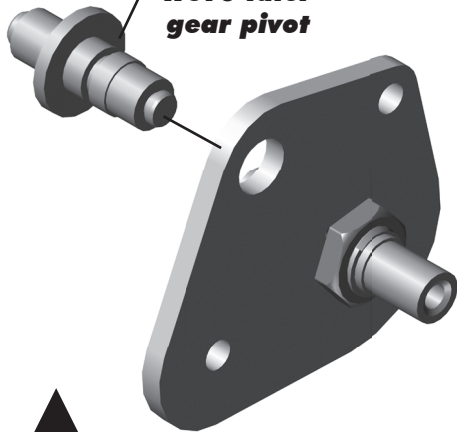

Curved side of
bowed E-Clip
should point
outwards!



Racer's Tip:
Use a small amount of
CA glue on idle pivot hole.

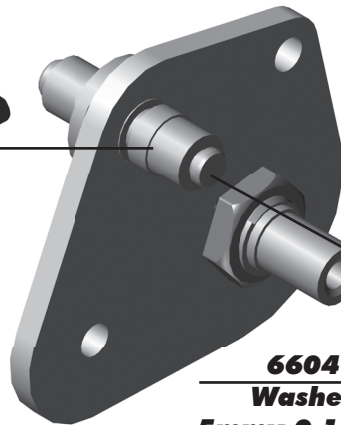

6604
Washer
5mm 0.17mm

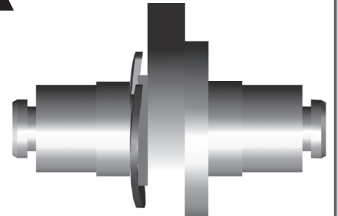

:: Transmission Build - Bag C-CC - Step 3

6630
Oilite bushing
3/16x5/16x1/4

6612
RC10 axle
drive gear



A little in-out
play is normal on
the outdrives



Build 2
Snap internal
retaining clip
into groove
with internal
snap ring
pliers!

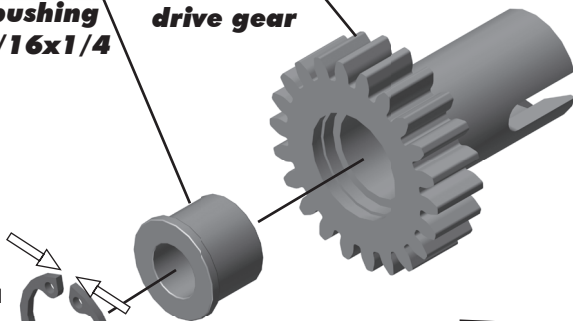

6604
RC10 internal
retaining clip

6920
4-40 x 3/16
BHCS

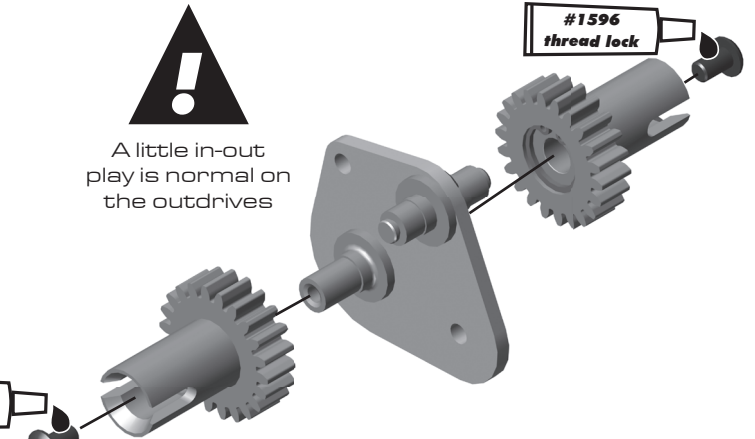

:: Transmission Build - Bag C-CC - Step 4

6630
Oilite bushing
3/16x5/16x1/8

6613 $\times 4$
RC10 idler gear

6299 $\times 2$
E-clip (small)

6613 $\times 4$
0-80 x 3/16 BHCS

Carefully tighten screws in x-pattern!

Build 2

:: Transmission Build - Bag C-CC - Step 5

6618
RC10 diff shaft and pinion

6627
RC10 diff thrust washers (small & large)

6617
RC10 diff pinion

6630
Oilite bushing
1/4 x 3/8 x 1/8

6623 $\times 2$
RC10 diff bushing

6605
RC10 bearing adapter

6617
RC10 diff tube w/hub

Slip the gear onto the tube and tap the assembly together using the handle of a hammer or a plastic handle of a screwdriver. Do not use a vise!

Use just enough black grease to cover the balls on the thrust bearing!

Press bushing in, make sure it is flush with diff hub!

Bushing

:: Transmission Build - Bag C-CC - Step 6

6634
Spur gear
81T, 48P

6626 $\times 8$
1/8 diff balls

Apply silicone grease into each hole of the spur gear before inserting diff balls. Insert diff balls opposite of stamped number on spur gear. Make sure they are evenly covered in lube!

Caution:
Do not get any grease on the back side of the diff drive rings or the diff hub.

6625
Diff drive rings

Make sure diff rings sit flat on hub!

:: Transmission Build - Bag C-CC - Step 7

Caution:
Do not get any grease on the back side of the diff drive rings or the outer hub.

6625
Diff drive rings

6624
RC10 diff outer hub

6628
RC10 diff spring

6629
5-40 locknut

Make sure diff rings sit flat on hub!

Lock nut should be flush with shaft to start!

:: Transmission Build - Bag C-CC - Step 8

6607
RC10 motor plate

6605
RC10 transmission case (right)

6605
RC10 transmission case (left)

6605
RC10 bearing adapter

6299
E-clip (small)

6630
Oilite bushing 3/16 x 5/16 x 1/8

1

2

Cutting a slot in the bearing adapter will make e-clip installation easier!

:: Transmission Build - Bag C-CC - Step 9

! Racer's Tip:
Use a dab of CA glue on the felt seals.

6633 $\Sigma 2$
RC10 felt

6633 $\Sigma 2$
RC10 felt seal

7260
4-40 plain nut (small)

! Press nut all the way inside the transmission case.

:: Transmission Build - Bag C-CC - Step 10

:: Rear Bulkhead Build - Bag D-DD - Step 1

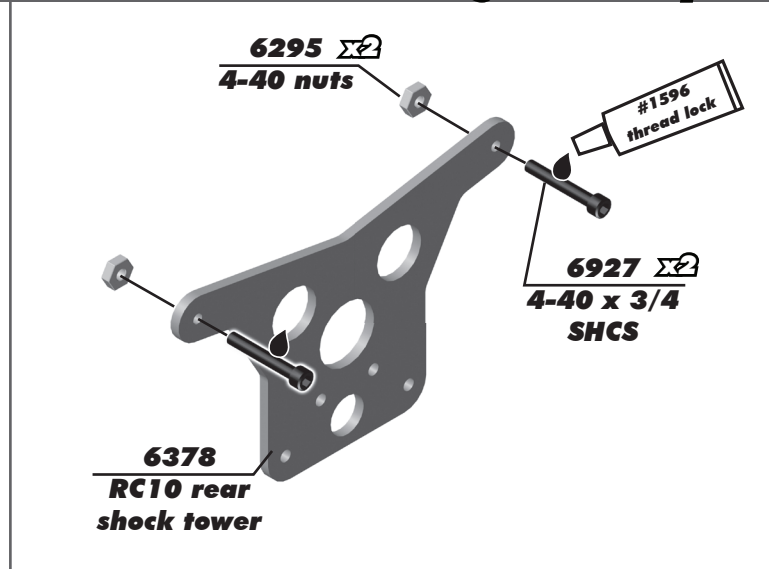
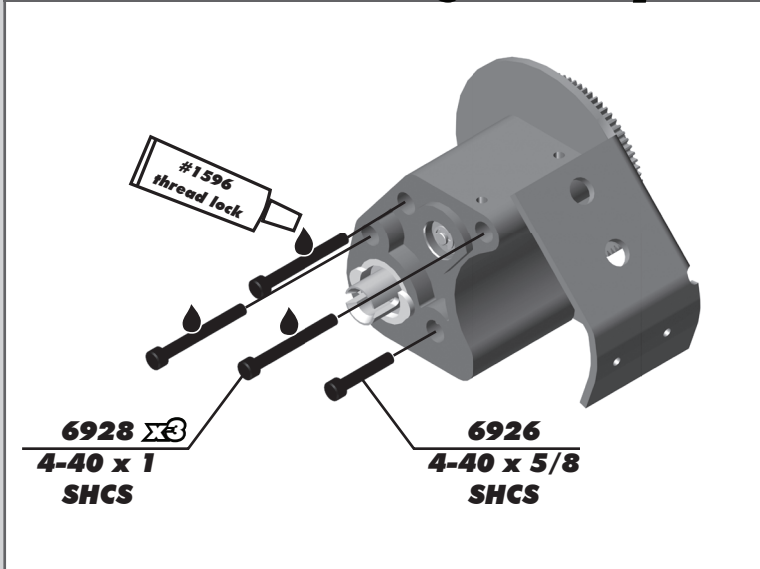

:: Rear Bulkhead Build - Bag D-DD - Step 2

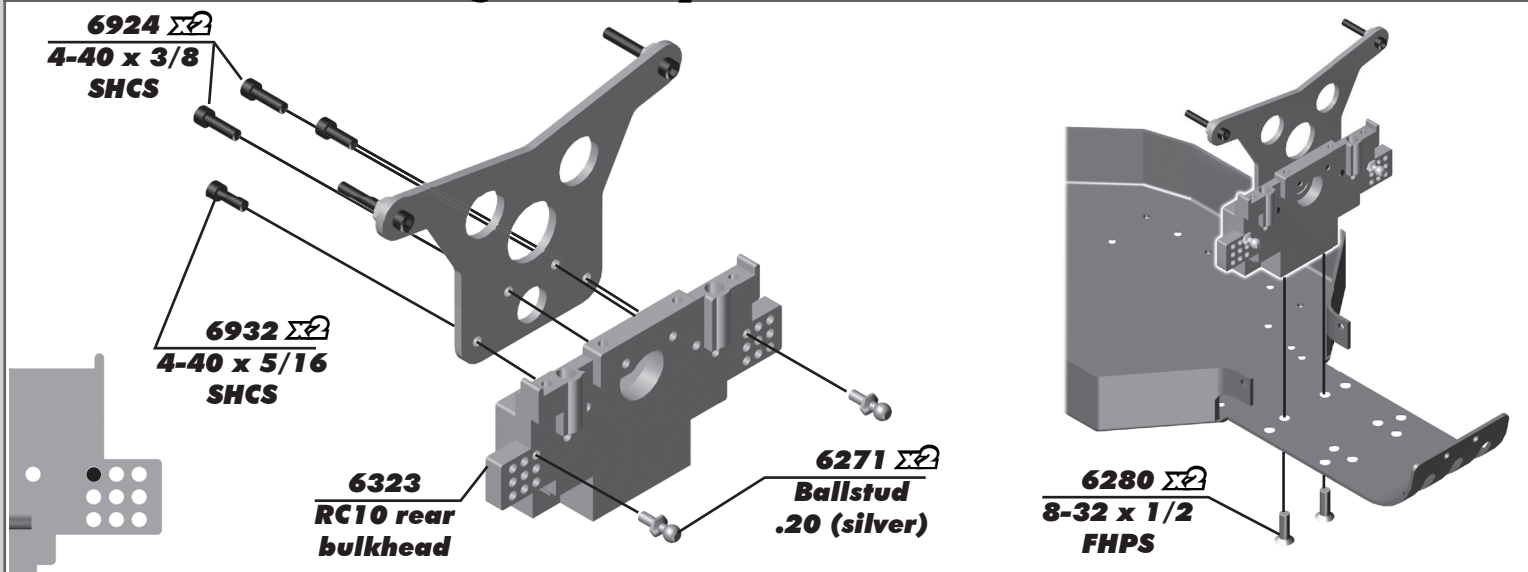

:: Rear Bulkhead Build - Bag D-DD - Step 3

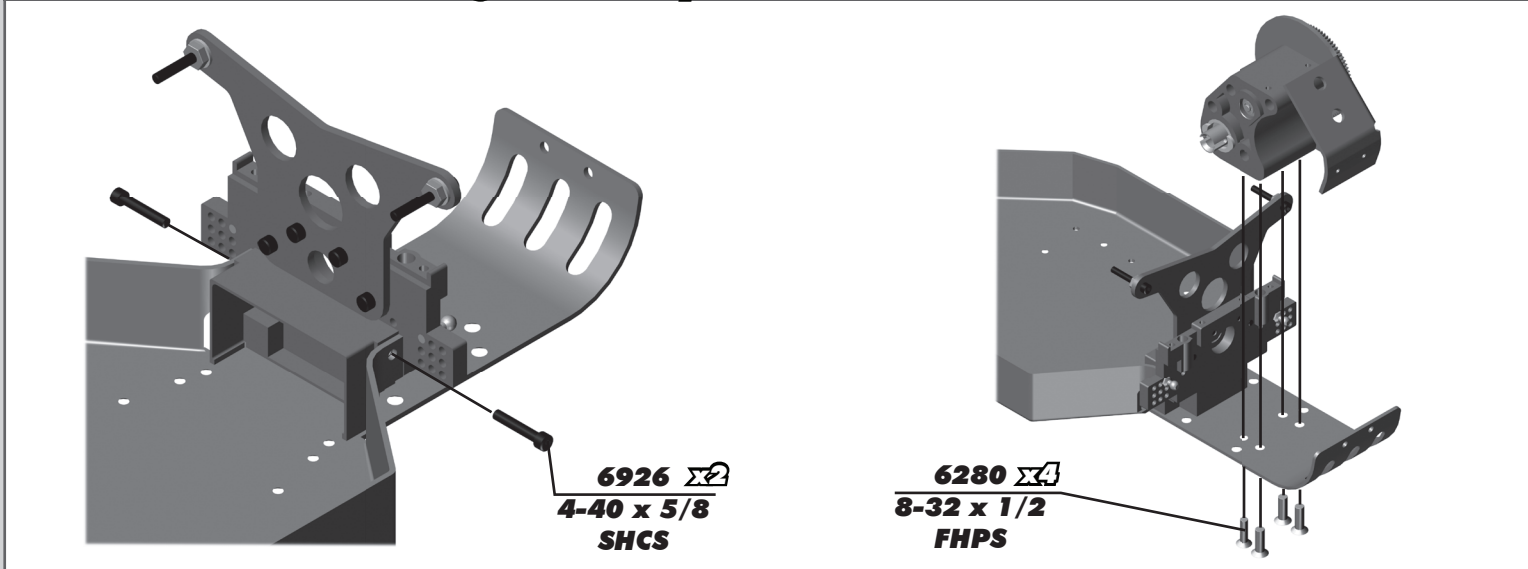

:: Rear Bulkhead Build - Bag D-DD - Step 4

6331
RC10 body mounts (white)

6326
RC10 transmission brace

6280
8-32 x 1/2 FHPS

6925 x4
4-40 x 1/2 SHCS

6936 x4
#4 aluminum washer

6327 x2
RC10 wing tubes

6285 x2
4-40 x 1/4 SHCS

#1596
thread lock

!
Press wing tubes into bulkhead!

!
Racer's Tip:
Use a small amount of CA glue on wing tube ends before inserting into bulkhead.

:: Rear Suspension Build - Bag E-EE - Step 1

6380
RC10 rear inner hinge pins

6360
RC10 rear arm mounts

6355
RC10 rear arms

6299 x2
E-clip (small)

6280 x2
8-32 x 1/2 FHPS

!
Forward holes

!
Build left and right sides!

!
Build left and right sides!

:: Rear Suspension Build - Bag E-EE - Step 2

6365
RC10 rear hub carrier (Left & Right)

6374
1/4 rear stub axle

6373 x3
1/4 axle shims

6630 x3
Oilite bushing 1/4 x 3/8 x 1/8

6271 x2
Ballstud .20 (silver)

6375
Roll pins .1 dia x 3/8

!
Build left and right sides!

!
Build left and right sides!

:: Rear Suspension Build - Bag E-EE - Step 3

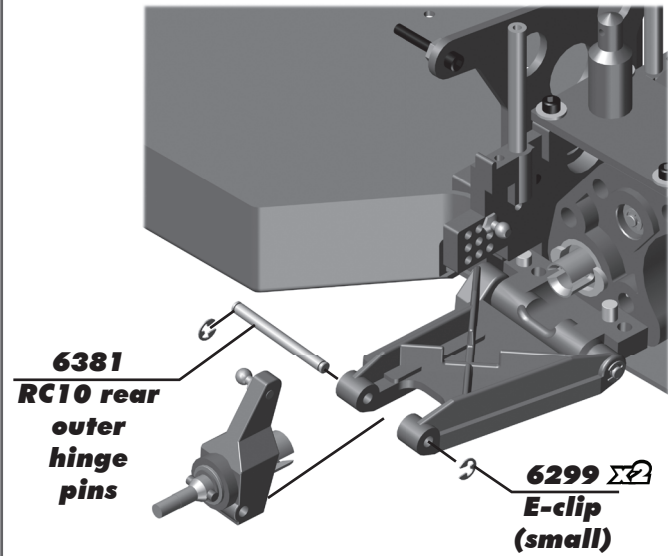

2

6372
Dogbone
spacer
6370
Dogbone

1

6372
Dogbone
spring

!
**Build left and
right sides!**

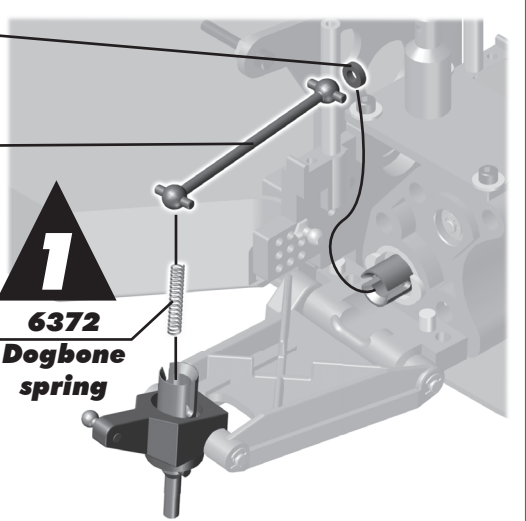

:: Turnbuckles Build - Bag F - Step 1

! Use a pair of pliers or wire cutters to carefully hold the turnbuckle while threading on ball cups.

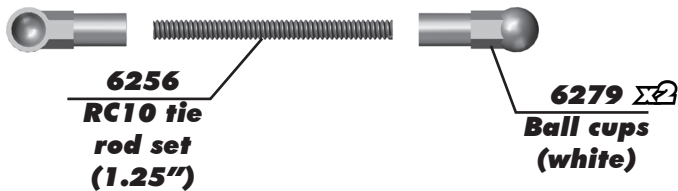

Rear Camber Turnbuckle
0.56" (14.20mm)

**Build left and
right sides!**

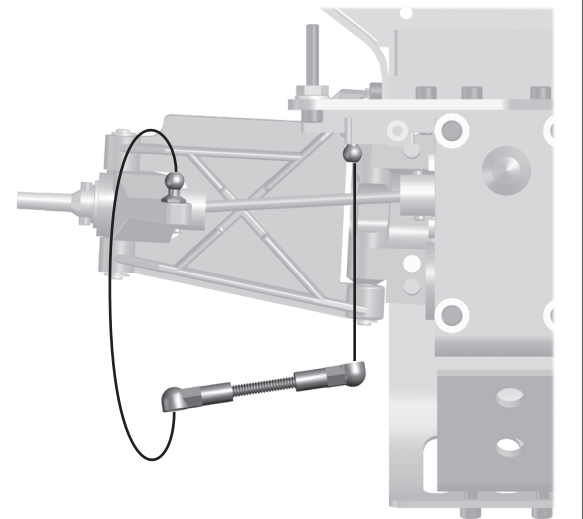
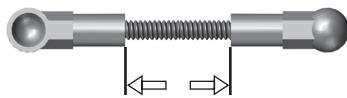

:: Turnbuckles Build - Bag F - Step 2

! Use a pair of pliers or wire cutters to carefully hold the turnbuckle while threading on ball cups.

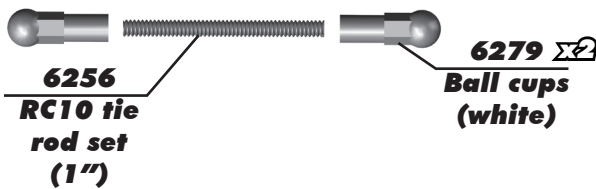

Steering Rack Turnbuckle
0.49" (12.44mm)

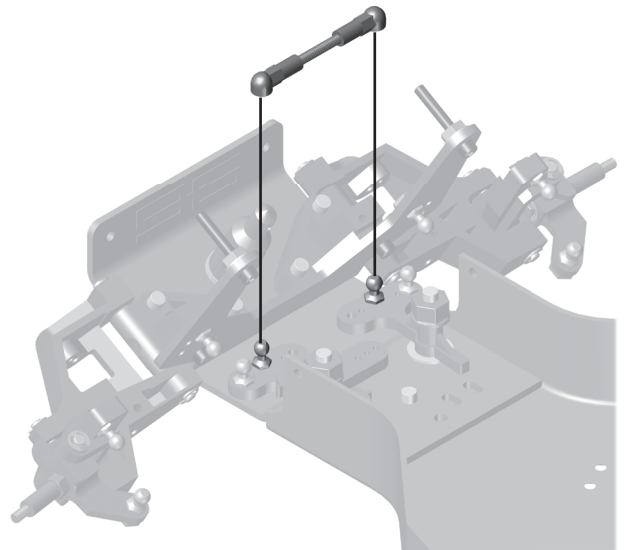
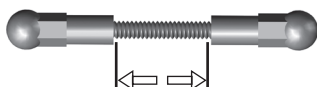

:: Turnbuckles Build - Bag F - Step 3



Use a pair of pliers or wire cutters to carefully hold the turnbuckle while threading on ball cups.



**Front Camber Turnbuckle
0.53" (13.5mm)**

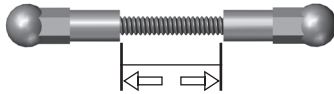

Build left and right sides!

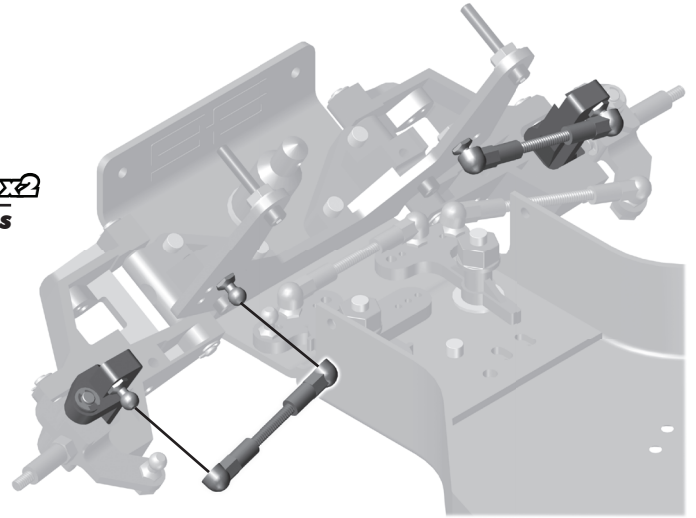

:: Turnbuckles Build - Bag F - Step 4



Use a pair of pliers or wire cutters to carefully hold the turnbuckle while threading on ball cups.

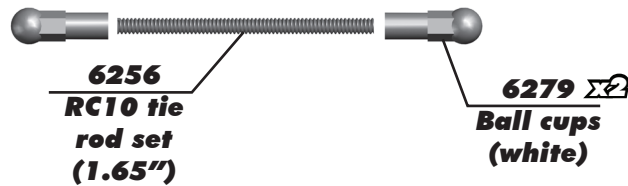

**Steering Turnbuckle
1.09" (27.70mm)**



Build left and right sides!

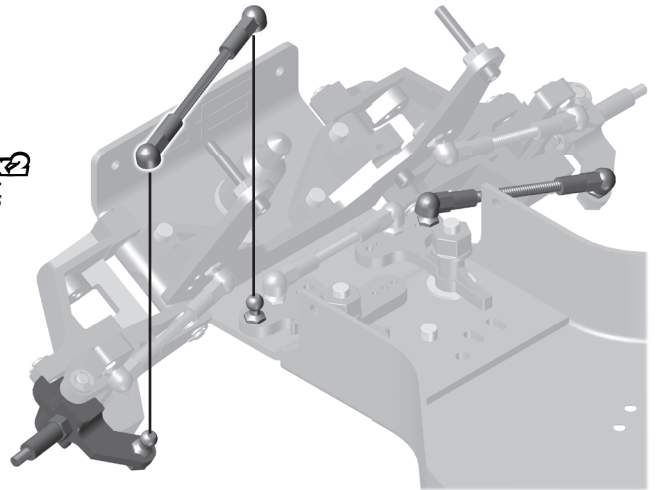

:: Shocks Build - Bag G-GG - Step 1

Remove spurs

Piston

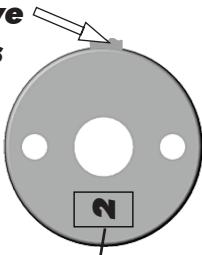

**Piston number here
Use #2 = front shocks
Use #2 = rear shocks**

6299 E-clip (small)

6461 Shock shaft, front (0.56)

6458 Shock shaft, rear (1.32)



6465 Shock pistons (1, 2, 3)

6299 E-clip (small)

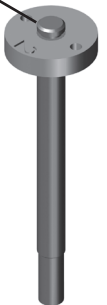

TIP: Use marker to mark the piston numbers for easy identification!

Build two front and two rear shock shafts!

:: Shocks Build - Bag G-GG - Step 2

5407 X2
Red o-ring

6440 X2
Off-road shock rebuild kit

6429
Shock assembly tool

6449
Shock body, front (0.56)

6446
Shock body, rear (1.32)

Shock fluid 30wt #5422

SNAP!

SNAP!

!
Place on table and push down hard until clamp snaps into place

:: Shocks Build - Bag G-GG - Step 3

Front Shock

Rear Shock

6469
Shock cap o-ring

6466 X2
Shock downstops

6468
Shock pivot ball

6468
Shock rod end

Build x2 front and x2 rear shocks

:: Shocks Build - Bag G-GG - Step 4

6450
RC10 shock cap

Shock fluid 30wt #5422

Step 1-3

Step 3-4

Step 5-6

Step 7

* Shock Bleeding Steps:

1. Pull shock shaft down.
2. Fill shock body 3/4 full with silicone fluid.
3. Slowly move the shock shaft up and down to remove air from under piston.
4. Wait for bubbles to come to surface.
5. Fill shock body to top with silicone fluid.
6. Place several drops of oil in the cap and on cap threads.
7. Install cap and tighten completely.
8. Slowly compress shaft all the way to the top. If there is pressure at the top of the stroke, there is too much oil. You must bleed it out.
9. Slowly pull shaft down.
10. Unscrew the cap 3/4 turn and tilt the shock at a slight angle.
11. Slowly compress the shaft to push out excess oil and air. You should see bubbles coming out from under the cap.
12. With the shaft compressed, tighten the cap and re-check for pressure at the top of the stroke. If there is still pressure, repeat steps 9 thru 11.

:: Shocks Build - Bag G-GG - Step 5

6451 RC10 shock collar

6924 4-40 x 3/8 SHCS

6496 Front shock spring, silver (3.85lb)

6478 Rear shock spring, silver (2.10lb)

6451 RC10 spring cup

Front: 6.5mm

Rear: 0mm

Build x2 front and x2 rear shocks

:: Shocks Build - Bag G-GG - Step 6

6936 #4 aluminum washer

6242 4-40 locknut

6451 RC10 shock bushing

4436 4-40 x 5/16 set screw

6224 Lower shock pin

Build left and right sides!

Make sure the set screw engages the groove on the shock pin!

:: Shocks Build - Bag G-GG - Step 7

6936 #4 aluminum washer

6242 4-40 locknut

6927 4-40 x 3/4 SHCS

6451 RC10 shock bushing

Build left and right sides!

:: Chassis Build - Bag H - Step 1

2
6917
4-40 x 3/8
BHCS

1
6288
4-40 x 1/4
BHCS

6320
RC10 nose
brace tubes

6338
Antenna tube
and cap

6337
RC10
antenna
mount

6292
4-40 x 3/8
FHCS

#1596
thread lock

Build left and right sides!

:: Electronics Build - Bag I - Step 1

6936
#4 aluminum
washer

6333
RC10 battery
cup and strap

6916 X2
4-40 x 1/2
SHCS w/hole

6951 X2
4-40 x 1/8
set screw

6255 X2
1/8 set
collar

6255 X2
Z bend
servo wire

#1596
thread lock

!
Wires may need to be bent slightly to clear some servos, depending on configuration!

:: Electronics Build - Bag I - Step 2

!
Align Z-bend wires so that the set screw tightens down on both wires at once!

6337 X2
RC10
servo
mounts

Servo not included!

6924 X4
4-40 x 3/8
SHCS

Servo horn and screw not included!

6936 X4
#4 aluminum
washer

89007
Servo horn
(recommended)

:: Electronics Build - Bag 1 - Step 3

Follow steps below to properly install Z bend wire into servo horn and steering link.



NOTE: Hole choice may vary depending on servo and servo horn used.

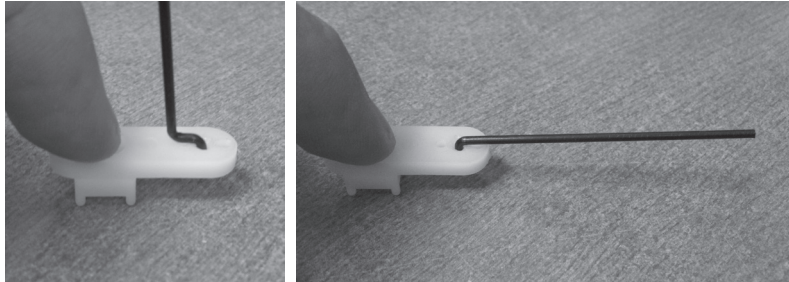

- 1) Press down on the Z bend wire....
- 2) Rotate the wire so the Z bend wire is fully installed into steering link as shown.

TIP: Chamfering the top of the hole slightly will help to press in Z bend wire.

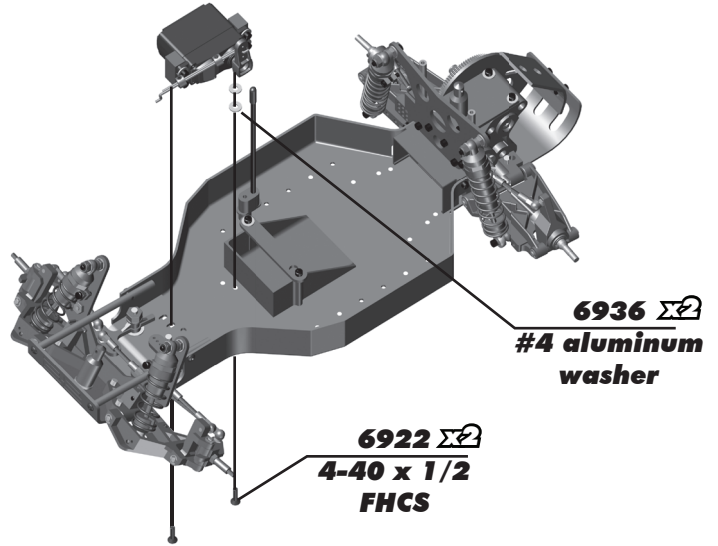

:: Electronics Build - Bag 1 - Step 4

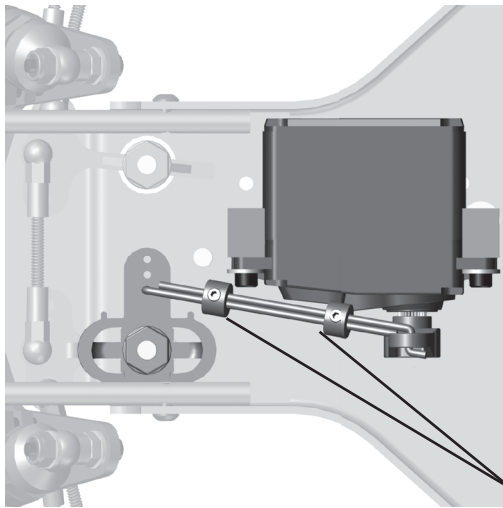

Install Z bend servo wire into steering bellcrank as shown. Ensure that full steering throw can be achieved with your servo horn setup!



Space collars as wide as possible while still clamping both wires.

Receiver not included!

ESC not included!

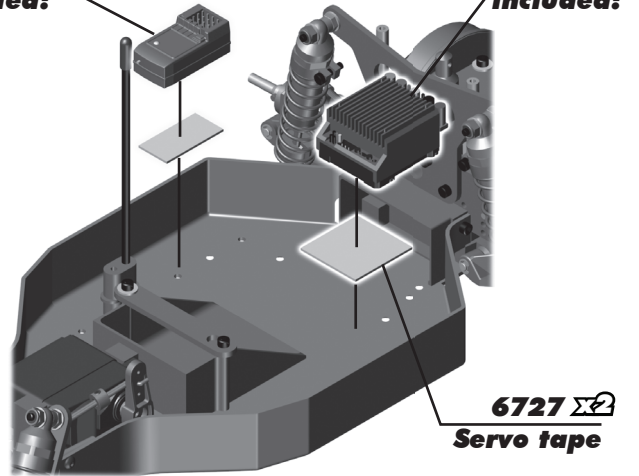

:: Electronics Build - Bag 1 - Step 5

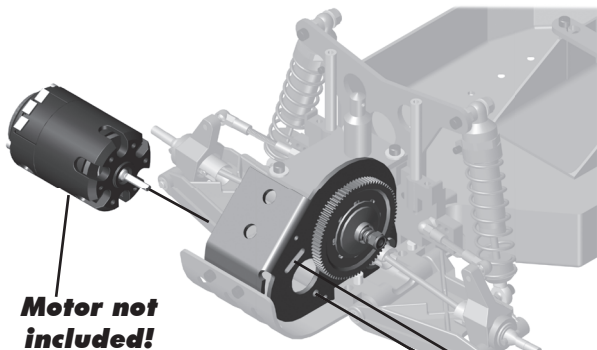

Motor not included!

Pinion not included!



See page 20 to set gear mesh properly!

31531 $\Sigma 2$
3 x 6mm BHCS

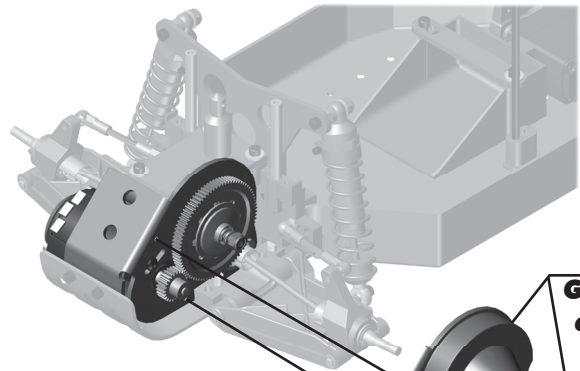

6608
Gear cover and plug

6920 $\Sigma 2$
4-40 x 3/16 BHCS

:: Electronics Build - Bag I - Step 6

Battery not included!

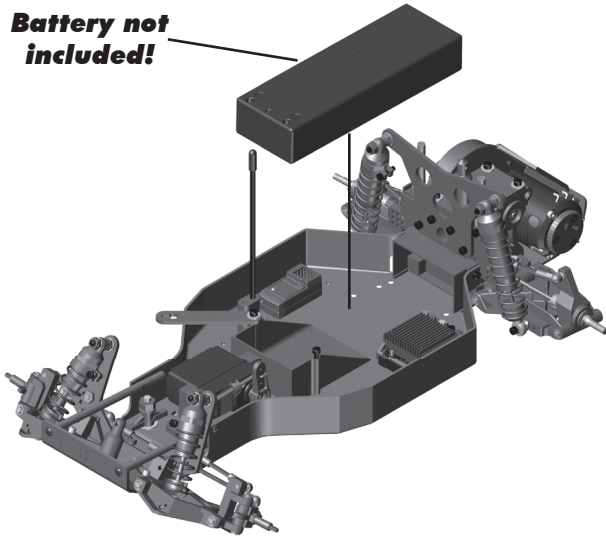

6332
Body clip

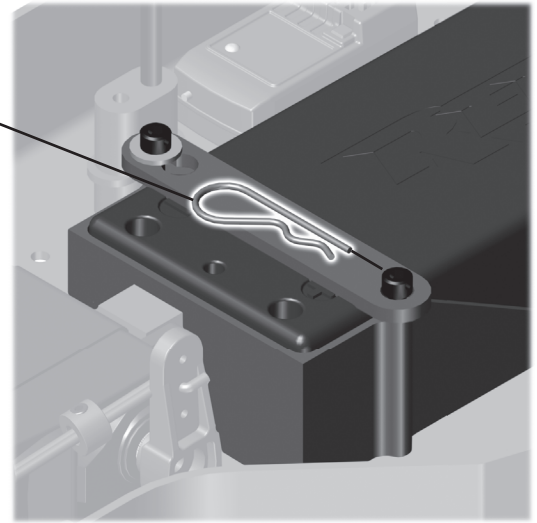

:: Wheels / Tires and Body - Bag J - Step 1

TIP: For faster motors, it is recommended to glue the tire bead to the wheels!

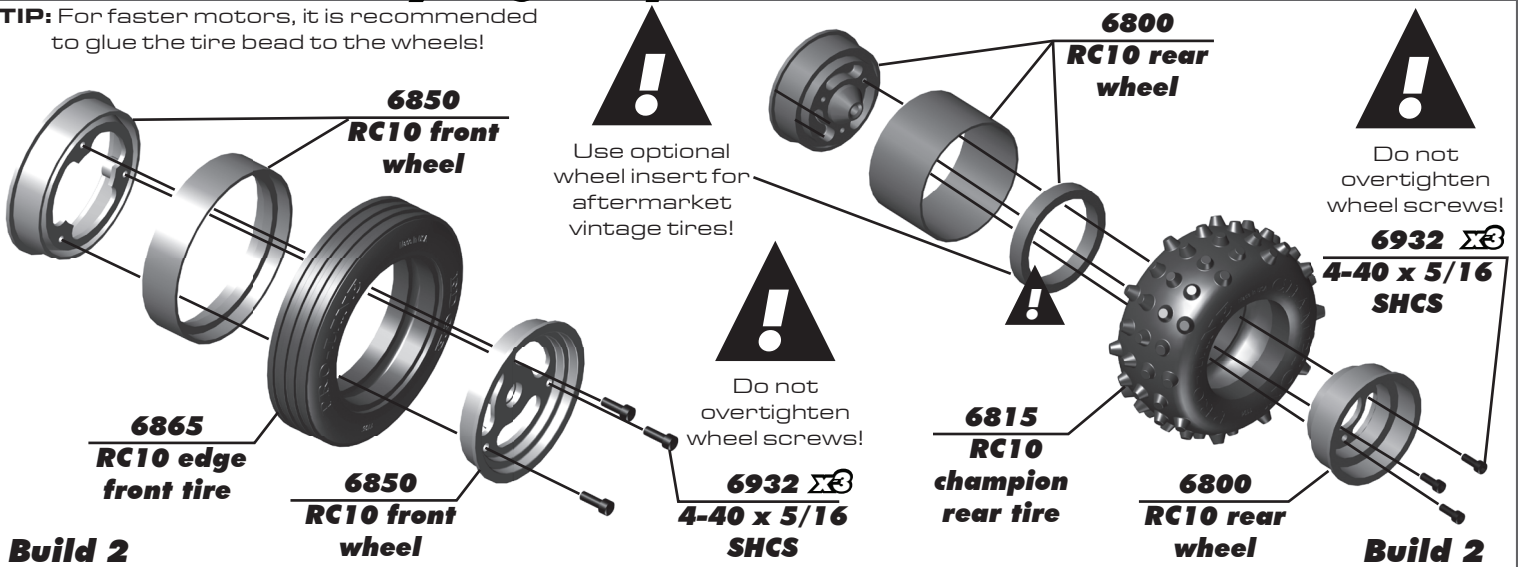

:: Wheels / Tires and Body - Bag J - Step 2

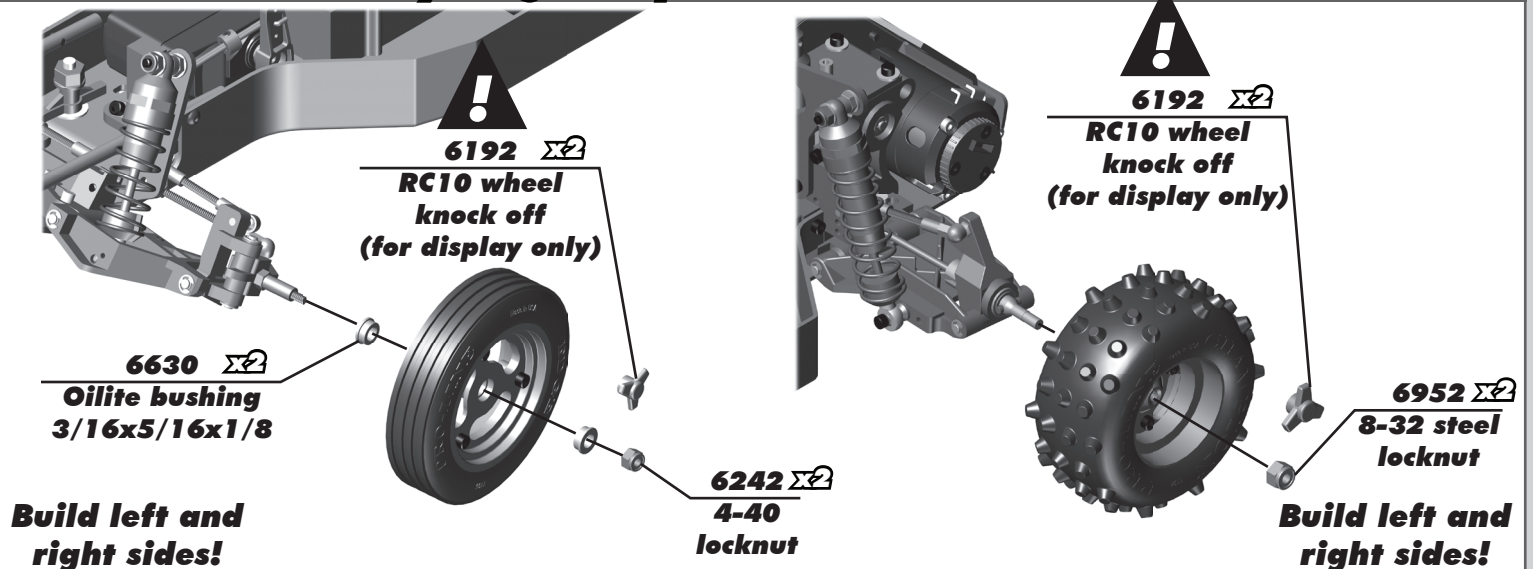

:: Wheels / Tires and Body - Bag J - Step 3

Painting Tips:

Body and Wing:

Your RC10 Classic comes with a clear polycarbonate body and wing. You will need to prep the body and wing before you can paint them. Wash the inside thoroughly with warm water and liquid detergent. Dry the body and wing using a clean, soft, lint-free cloth. Use high quality masking tape to make masks for the windows and install them on the inside of the body. (RC cars get painted from the inside). Using high quality masking tape, apply tape to the inside of the body to create a design. Spray (either rattle can or airbrush R/C specific paint) the paint to the inside of the body (preferably dark colors first, lighter colors last).

NOTE: use ONLY paint that is recommended for use with (polycarbonate) plastics. If you do not, you can destroy the plastic body and wing!!!!).

After painting, cut the body and wing along the trim lines. Make sure to drill or use a body reamer to make the holes for the body mounts, wing mounts, and antenna!

**6160
Protech
Buggy
body,
unpainted**

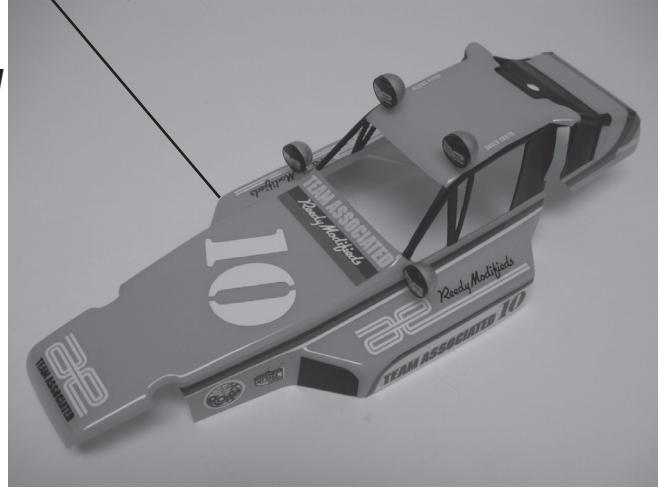

:: Wheels / Tires and Body - Bag J - Step 4

Light Buckets:

Press the light bucket halves together. You can use CA glue if you would like. You can paint or dye the light buckets to any desired color. Install light buckets with #9898 SHCS in areas shown.

**6192
Light
buckets**

**9898 ~~24~~
2-56 x 3/16
SHCS**

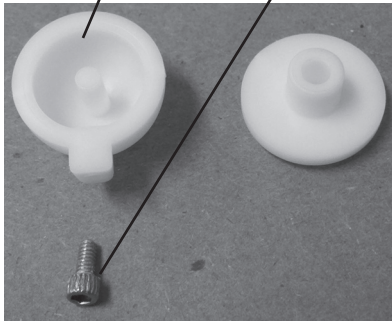

Mount the light buckets in any location of your choosing, or not at all.



:: Wheels / Tires and Body - Bag J - Step 5

Painting Tips:

Driver :

Your RC10 Classic comes with a clear polycarbonate driver figure. You will need to prep the driver figure before you can paint it. Wash the inside and outside thoroughly with warm water and liquid detergent. Dry the driver figure using a clean, soft, lint-free cloth. The driver figure can be painted from the inside or the outside, depending on what type of finish you would like. If painted from the inside, the painted sections will appear glossy. If painted on the outside, the painted sections will appear flat or matte finished. Trim as shown and install inside the body using strapping tape. After painting, cut the body and wing along the trim lines.

NOTE: use ONLY paint that is recommended for use with (polycarbonate) plastics. If you don't, you can destroy the plastic body, driver figure, and wing!!!!.

**6180
RC10
driver
figure,
clear**

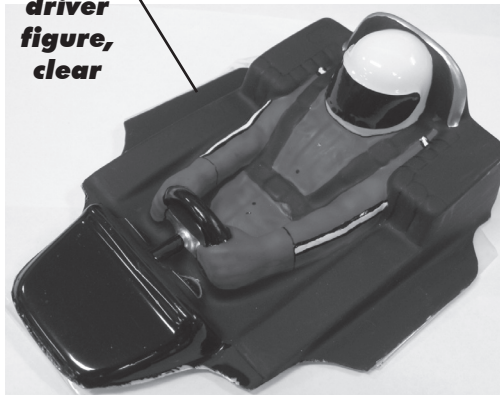

:: Wheels / Tires and Body - Bag J - Step 6

6332
Body
clip



6332
Body
clip

:: Wheels / Tires and Body - Bag J - Step 7

6187
Wing,
clear

6192 
Wing
mounts

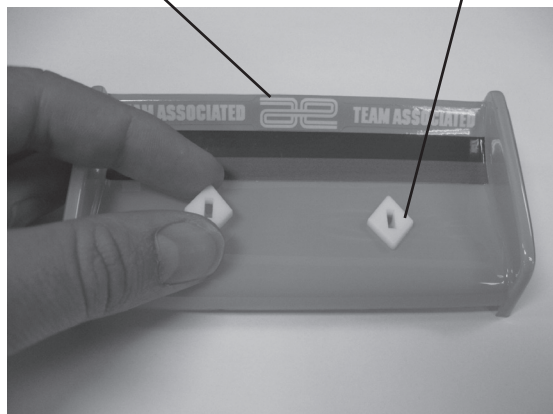

6191
Wing mount
wire

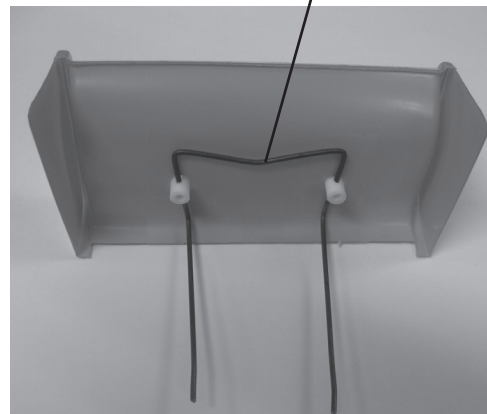

:: Wheels / Tires and Body - Bag J - Step 8

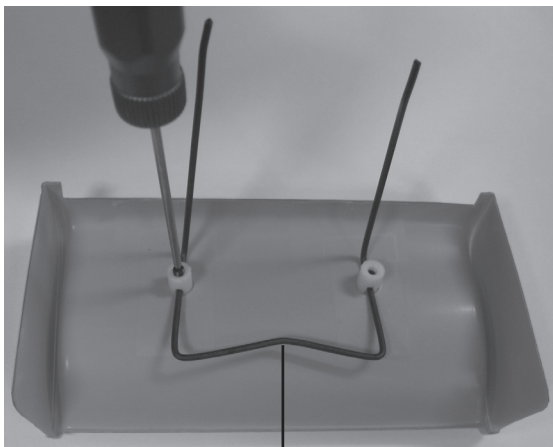

TIP: Bending the wire as shown can help ensure the wing buttons are parallel.



TIP: Bend wire to create tight fit inside wing tubes.



:: Tuning Tips

Tips for Beginners:

Before making any changes to the standard setup, make sure you can get around the track without crashing. Changes to your vehicle will not be beneficial if you can't stay on the track. Your goal is consistent laps. Once you can get around the track consistently, start tuning your vehicle. Make only ONE adjustment at a time, testing it before making another change. If the result of your adjustment is a faster lap, mark the change on the included setup sheet (make additional copies of the sheet before writing on it). If your adjustment results in a slower lap, revert back to the previous setup and try another change. When you are satisfied with your vehicle, fill in the setup sheet thoroughly and file it away. Use this as a guide for future track days or conditions.

Periodically check all moving suspension parts. Suspension components must be kept clean and move freely without binding to prevent poor and/or inconsistent handling.

Motor Gearing:

Proper motor gearing will result in maximum performance and run time while reducing the chance of overheating and premature motor failure. The gear ratio chart lists recommended starting gear ratios for the most widely used motor types. Gear ratios will vary depending upon motor brand, wind, and electronic speed control. Consult your motor and electronic speed control manufacturers for more information. Team Associated is not responsible for motor damage due to improper gearing. * These gearings are for use with advanced timing speed control settings!

RC10 Classic Gear Ratio Chart (Internal Gear Ratio 1.83:1)

Motor	Pinion	Spur	FDR
27T Stock Brushed	18	81	8.23:1
19T Super Stock Brushed	18	81	8.23:1
17.5 Reedy Sonic Brushless *	19	81	7.80:1
17.5 Reedy Sonic Brushless	27	81	5.49:1
13.5 Reedy Sonic Brushless *	18	81	8.23:1
13.5 Reedy Sonic Brushless	26	81	5.70:1
10.5 Reedy Sonic Brushless	19	81	7.80:1
9.5 Reedy Sonic Brushless	18	81	8.23:1
8.5 Reedy Sonic Brushless	18	81	8.23:1

Due to the original design of the RC10, motors exceeding the power of a 8.5T motor are **NOT** recommended, to prevent damage to the drivetrain!

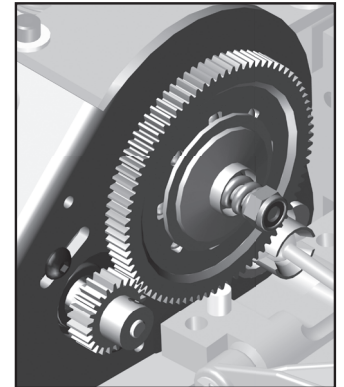

Set The Gear Mesh:

You should be able to rock the spur gear back and forth in the teeth of the pinion gear without making the pinion gear move. If the spur gear mesh is tight, then loosen the #31531 screws and move the motor away, then try again. A gear mesh that is too tight or too loose will reduce power and damage the gear teeth.

VariLok Diff Adjustment Tips:

Be sure to only use Associated diff lube #6636, and apply a small amount on both sides of the diff balls. Do not use this diff grease anywhere else on the vehicle! It is not intended as a lubricant (Use only Associated diff lube as it has special additives to ensure the balls roll instead of slide).

The RC10 Classic is not equipped with a slipper clutch like most current R/C vehicles are. Therefore, particular care and attention is necessary when setting the VariLok differential. Set the differential by starting with the 5-40 nut flush with the end of the diff shaft. Next, turn on the car and hold the tires (as seen below) with transmitter in hand. Quickly give the car a 75-100% burst of throttle. Note, if the spur gear spins and the car does not move forward then the diff is too loose. Adjust the diff nut in 1/8 turn increments until the spur gear doesn't slip. At this point, the diff is set as free as possible without slipping. Tightening the diff nut even further will increase the amount of power that is transferred to the tire that has the most load and will not 'diff out' as easily. Locking down the diff nut is not recommended because the only slipping that can occur will be between the drive rings and hubs. This can create a tremendous amount of heat.

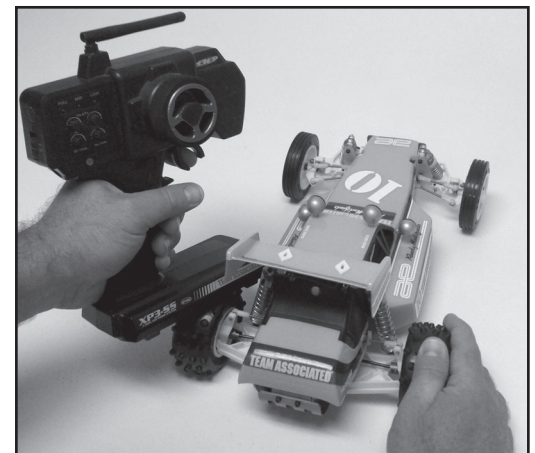

Wheelbase Adjustment:

The wheel base on the RC10 Classic can be adjusted by moving the rear arm mounts forward or backwards. The kit setting has the arm mount back which provides the most stability over bumps and rhythm sections. Going to the shorter wheelbase option will improve rear traction.

:: Tuning Tips (cont.)

Front Camber Links:

Changing the length of the camber link is considered a bigger step than adjusting the ball end height on the tower. Shortening the camber link (or lowering the ball end) will give the front end less roll and quicken steering response. Lengthening the camber link (or raising the ball end) will give the front more roll and slower steering response. Longer camber links are typically used on high grip tracks and shorter links tend to work better on medium-grip loose tracks.



*Raise or lower the ball end on the front shock tower

Front Camber:

Camber describes the angle at which the tire and wheel rides when looked at from the front. Negative camber means that the tire leans inward at the top. A good starting camber setting is -1° . Use the included # 1719 camber gauge to set your camber. Positive camber, where the top of the tire is leaning out, is not recommended.

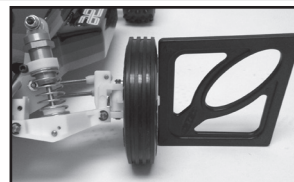

*Checking camber with camber gauge

Caster:

Caster describes the angle of the kingpin as it leans toward the rear of the vehicle. Positive caster means the kingpin leans rearward at the top. The supplied 15° caster blocks (#6213) are recommended in most cases. For less corner entry steering and more exit steering, try the optional 30° caster blocks (#6210). Optional 30° caster blocks may require trimming of the stock front arms for clearance.

Rear Camber Link:

Changing the length of the camber link is considered a bigger step than adjusting the ball end height on the rear chassis brace. Shortening the camber link (or lowering the ball end) will give the rear end less roll and the car will tend to accelerate or "square up" better. Lengthening the camber link (or raising the ball end) will give the rear more roll and more cornering grip. Longer camber links are typically used on high grip tracks, while shorter links tend to work better on medium grip loose tracks. The far inside hole was a tuning option introduced later on. It requires a 1.65" turnbuckle (#6262, 1403, or 6256)



*Raise or lower the ball end by adjusting the ballstud location on the bulkhead

Rear Camber:

Camber describes the angle at which the tire and wheel rides when looked at from the back. Negative camber means that the tire leans inward at the top. A good starting camber setting is -1° . Use the included # 1719 camber gauge to set your camber. Adding a small amount of positive camber, where the top of the tire is leaning out, will tend to improve straight-line acceleration on loose tracks.

Ride Height:

Ride height is the distance from the ground to the bottom of the chassis. The standard front ride height setting is with the front arms just below level or 24mm (Ride Height Gauge # 1449). Check the ride height by lifting up the entire car about 8-12 inches off the bench and drop it. After the suspension "settles" into place, measure ride height (Ride Height Gauge # 1449). Raise or lower the shock collars as necessary so that the left & right arms appear to be level.

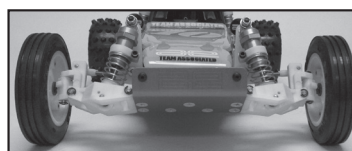

*Front arms should be just below level ride height

The rear ride height setting you should use most often is with the outdrive, driveshaft, and axles all on the same imaginary horizontal line (referred to as "bones level") or 24mm (Ride Height Gauge # 1449). Check the ride height by lifting up the entire car about 8-12 inches off the bench and drop it. After the suspension "settles" into place, measure ride height (Ride Height Gauge # 1449). Raise or lower the shock collars as necessary so that the left & right driveshafts appear to be level.

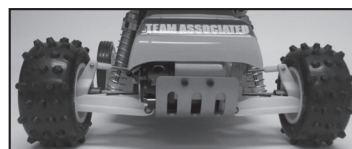

*Dog bones should be in a straight line when ride height is set at "Bones level"



*TIP: Set the rear dog bones level and then adjusting the front to make the chassis parallel to the ground.

Motor Maintenance:

Brushed motors require frequent maintenance to keep performance levels at their maximum. Between runs and after letting the motor cool completely, inspect the brushes to ensure that they are moving freely in their holders. Remove the springs and slide the brushes in and out of their holders checking for any resistance or rough spots. If found, remove the brush and carefully wipe it clean. Removing buildup will allow the brush to slide freely and create maximum contact with the commutator resulting in maximum power output. After every 3-5 runs, remove the brushes from their holders and inspect the tips for wear or burning. If there is noticeable wear (less than 75% of the brush remaining), it is best to cut the commutator and replace the brushes with a new pair. If the tips become a burned blue color, the lubricant in the brush has been burned away and new brushes should be installed. Occasionally, the motor should be cleaned with a soft brush to prevent dirt build up around the brush hood area and ball bearings. At this time, it is a good idea to add one drop of bushing / bearing oil to each bushing or ball bearing.

If using a brushless motor, please refer to the motor manufacturer's guidelines for proper maintenance.

:: Shocks

5407	Red O-Rings	8
6299	1/8" E-Clips	12
6429	Shock Assembly Tool	1
6440	Off Road Shock Rebuild Kit	1
6446	Shock Body, Rear (1.32)	1
6449	Shock Body, Front (0.56)	1
6450	RC10 Shock Cap	1
6451	RC10 Shock Accessories (spring retainer, clamp, bushing)	1
6458	Shock Shaft, 1.32" stroke	1
6461	Shock Shaft, .56" stroke	1
6465	Shock Piston, (1, 2, 3)	4ea.
6468	RC10 Shock Rod Ends / Pivots	2
6469	Black O-Ring	4
6924	4-40 X 3/8" SHCS	6

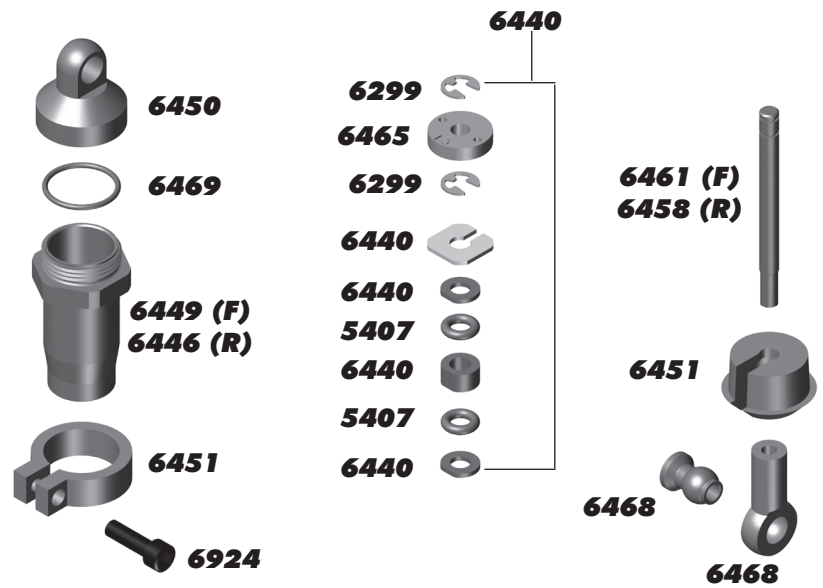

:: Springs

1581	Factory Team Buggy Front Spring Kit. 1 pr	1	
	of green, silver, blue, black springs		
1582	Factory Team Truck/Buggy Rear Spring Kit. 1	1	
	pr of green, silver, blue, gold, red springs		
6493	Front Buggy Spring Brown 2.80 lb	Pr.	
6494	Front Buggy Spring Green 3.50 lb	Pr.	
6496	Front Buggy Spring Silver 3.85 lb (Kit)	Pr.	
6497	Front Buggy Spring Blue 4.20 lb	Pr.	
8232	Front Buggy Spring Black 3.20 lb	Pr.	
6478	Rear Spring Silver 2.10 lb (Kit)	Pr.	
6480	Rear Spring Green 1.90 lb	Pr.	
6481	Rear Spring Black 1.74 lb	Pr.	
6482	Rear Spring Gray 2.33 lb	Pr.	
7434	Rear Spring Blue 2.55 lb	Pr.	
7435	Rear Spring Gold 2.75 lb	Pr.	
7436	Rear Spring Red 2.95 lb	Pr.	



:: Shock Fluid

5420	10 Weight Silicone Shock Fluid	2oz.
5421	20 Weight Silicone Shock Fluid	2oz.
5422	30 Weight Silicone Shock Fluid	2oz.
5423	40 Weight Silicone Shock Fluid	2oz.
5424	22.5 Weight Silicone Shock Fluid	2oz.
5425	80 Weight Silicone Shock Fluid	2oz.
5426	27.5 Weight Silicone Shock Fluid	2oz.
5427	15 Weight Silicone Shock Fluid	2oz.
5428	25 Weight Silicone Shock Fluid	2oz.
5429	35 Weight Silicone Shock Fluid	2oz.
5430	45 Weight Silicone Shock Fluid	2oz.
5431	55 Weight Silicone Shock Fluid	2oz.
5432	32.5 Weight Silicone Shock Fluid	2oz.
5433	37.5 Weight Silicone Shock Fluid	2oz.
5434	42.5 Weight Silicone Shock Fluid	2oz.
5435	50 Weight Silicone Shock Fluid	2oz.
5436	60 Weight Silicone Shock Fluid	2oz.
5437	70 Weight Silicone Shock Fluid	2oz.
5438	47.5 Weight Silicone Shock Fluid	2oz.



:: Slipper / Gear Cover

6605	RC10 Bearing Adapter	2
6608	Gear Dust Cover w/Plug	1
6617	RC10 Diff Tube w/Hub	1
6618	RC10 Diff Shaft & Pinion	1
6623	RC10 Diff Teflon Bushing	2
6624	RC10 Diff Outer Hub	1
6625	Diff Drive Rings	2
6626	1/8" Diff Balls	16
6627	RC10 Diff Thrust Bearing	1ea.
6628	RC10 Diff Spring & Nut	1
6629	5-40 Diff Locknut	6
6630	RC10 Oilite Bushing Set	1
6634	RC10 81T Spur Gear, 48P	1
6920	4-40 x 3/16" BHCS	6
31531	M3 x 6 BHCS	6

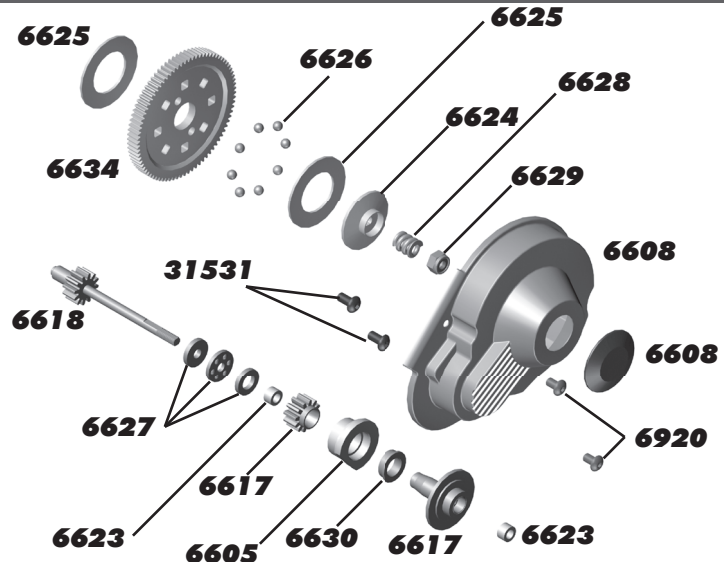

:: Turnbuckles / Servo

6255	RC10 Steering Assembly	1
6256	RC10 Tie Rod Set (2x 1", 4x 1.25", 2x 1.65")	1
6279	White Ball Cups	14
6337	RC10 Servo/Antenna Mount	1
6922	4-40 x 1/2" FHCS	6
6924	4-40 x 3/8" SHCS	6
6936	#4 Washer, Aluminum	10
6951	4-40 x 1/8" Set Screw	6
89007	Steering Servo Horn	1

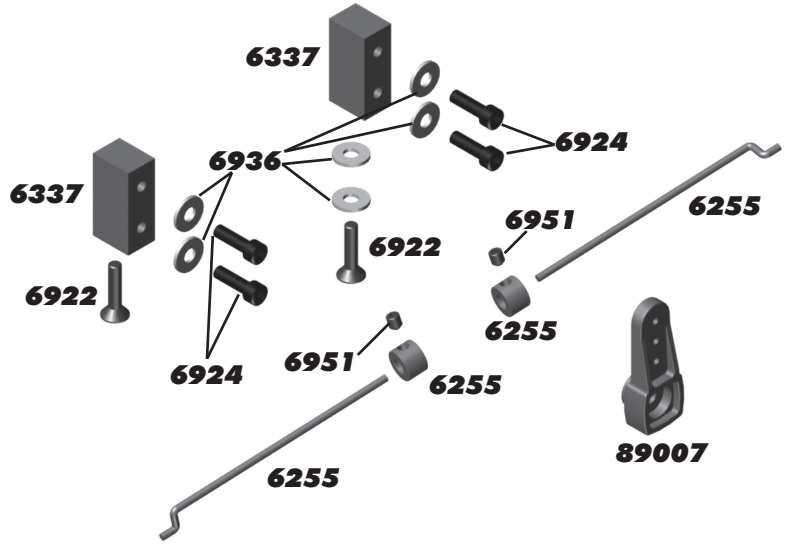

:: Steering

3323	#8 Aluminum Flat Washer, thick	12
6255	RC10 Steering Assembly	1
6271	Short Ballstud, stainless steel, short	12
6281	8-32 x 7/8" Aluminum FHPS	6
6282	8-32 Locknut, Nylon (White)	6

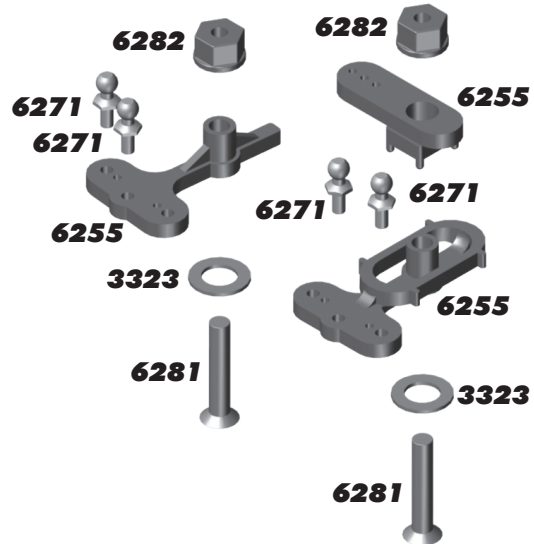

:: Antenna Mount / Battery Strap

6292	4-40 x 3/8" FHCS	6
6332	Body Clip	6
6333	RC10 Battery Cup	1
6337	RC10 Servo/Antenna Mounts	1
6338	Antenna Tube with Cap, black	1
6916	4-40 x 1/2" SHCS w/hole	6
6936	#4 Washer, Aluminum	10

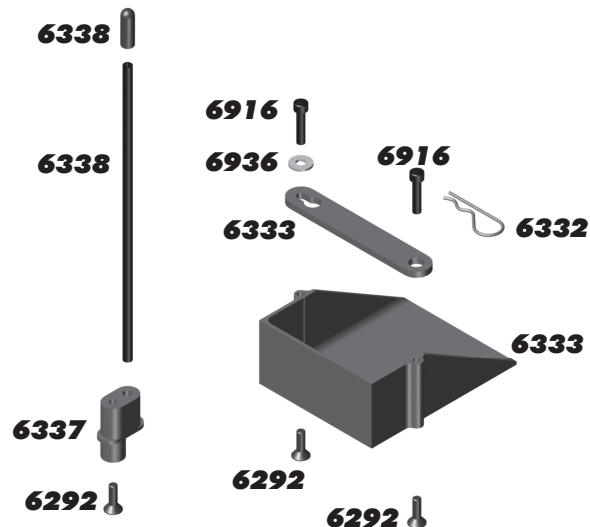

:: Front Arm

4187	Nylon Spacer, 1/32" (.030)	12
4436	4-40 x 5/16", Set Screw	4
6192	RC10 Accessories	1
6205	RC10 Front Arms	1ea.
6208	RC10 Front Arm Mounts	1ea.
6213	RC10 Front Caster Blocks, 15 deg	1ea.
6216	RC10 Steering Blocks	2
6219	RC10 Front Stub Axles	2
6223	RC10 King Pin w/Clips	2
6224	Lower Shock Pin	2
6226	RC10 Front Inner Hinge Pin	2
6227	Hinge Pin, outer, 1.020", w/ clips	1
6242	4-40 Steel Locknut	6
6271	Short Ballstud, stainless steel, .20	12
6280	8-32 x 1/2" Aluminum FHPS	16
6295	4-40 Nuts	18
6299	E-Clip, 1/8"	12
6630	RC10 Oilite Bushing Set	1

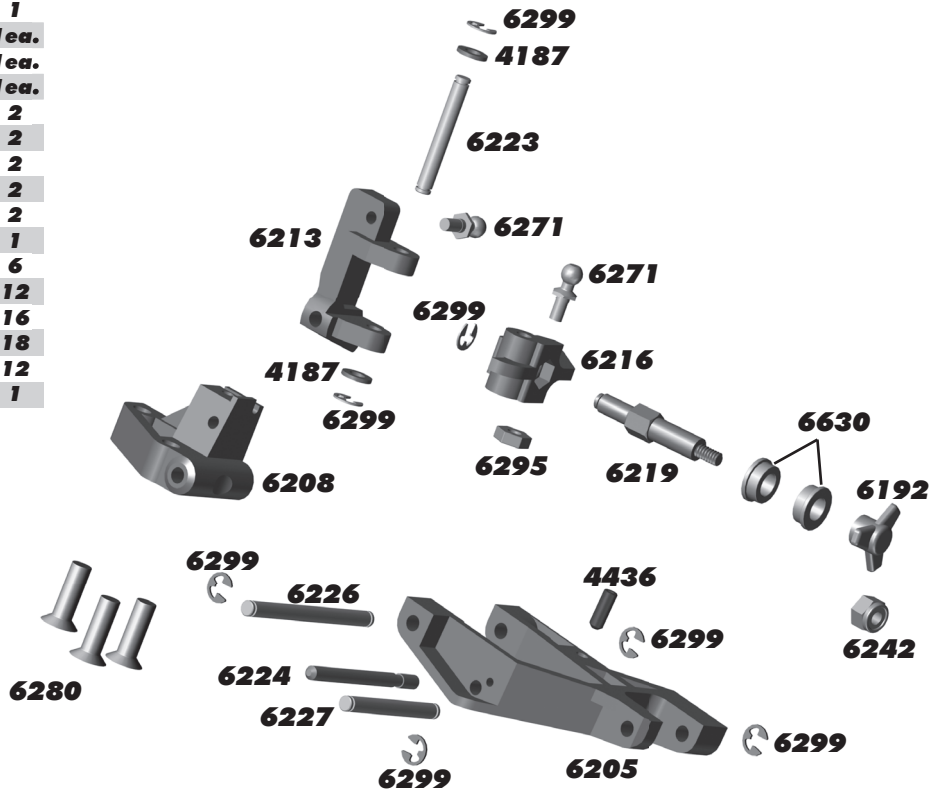

:: Rear Arm

6192	RC10 Accessories	1
6271	Short Ballstud, stainless steel, .20	12
6280	8-32 x 1/2" Aluminum FHPS	16
6299	E-Clip, 1/8"	12
6355	RC10 Rear Arms	1ea.
6360	RC10 Rear Arm Mounts	1ea.
6365	RC10 Rear Hub Carriers	2
6370	RC10 Dogbone	1
6372	1/16" Plastic Spacer, with spring	2
6373	1/4" Rear Axle Shims/Spacers	14
6374	Rear Stub Axle, with roll pin	1
6375	Roll Pin for Stub Axle	6
6380	RC10 Rear Inner Hinge Pins	2
6381	Hinge Pin, Rear, Outer	2
6630	RC10 Oilite Bushing Set	1
6927	4-40 x 3/4" SHCS	6
6952	8-32 Locknut, Steel	6

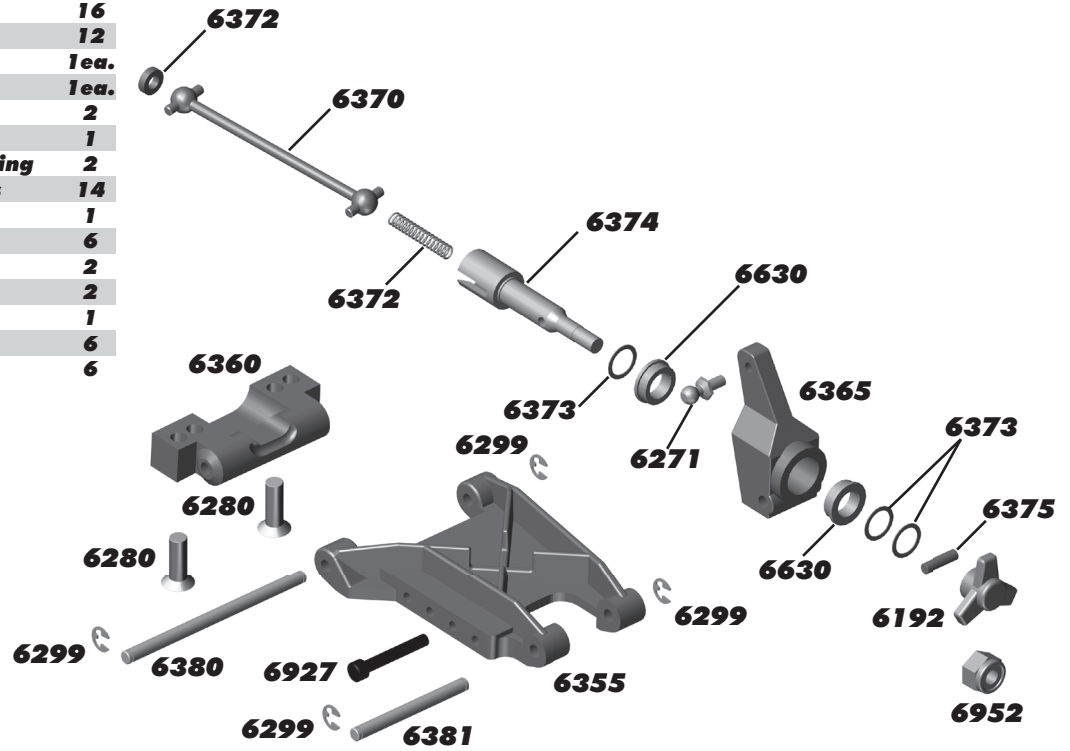

:: Front Shock Tower

6230	RC10 Front Shock Tower	1
6242	4-40 Locknuts, Steel	6
6271	Short Ballstud, Stainless Steel, .20	12
6295	4-40 Nuts	6ea.
6451	RC10 Shock Accessories	1
6925	4-40 x 1/2" SHCS	6
6927	4-40 x 3/4" SHCS	6
6936	#4 Washer, Aluminum	10

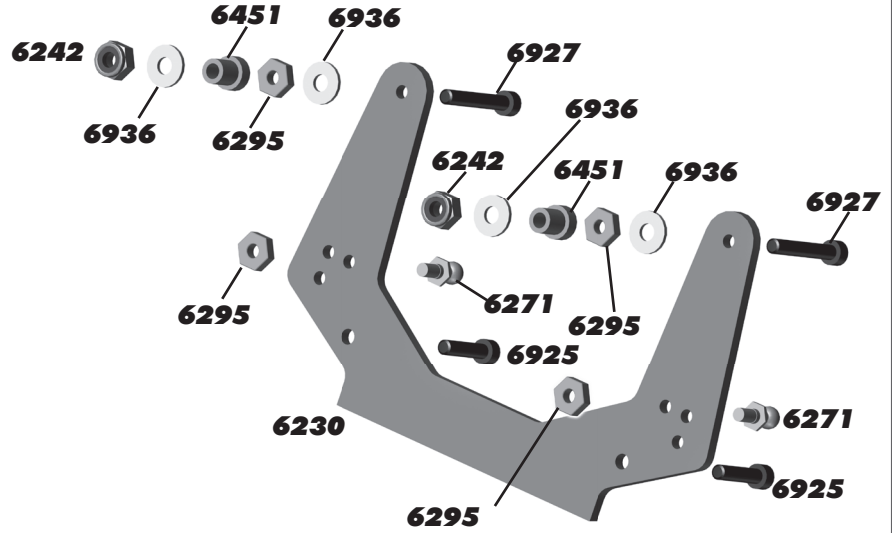

:: Rear Shock Tower

6242	4-40 Locknuts, Steel	6
6295	4-40 Nuts	6ea.
6378	RC10 Rear Shock Tower	1
6451	RC10 Shock Accessories	1
6924	4-40 x 3/8" SHCS	6
6927	4-40 x 3/4" SHCS	6
6932	4-40 x 5/16" SHCS	6
6936	#4 Washer, Aluminum	10

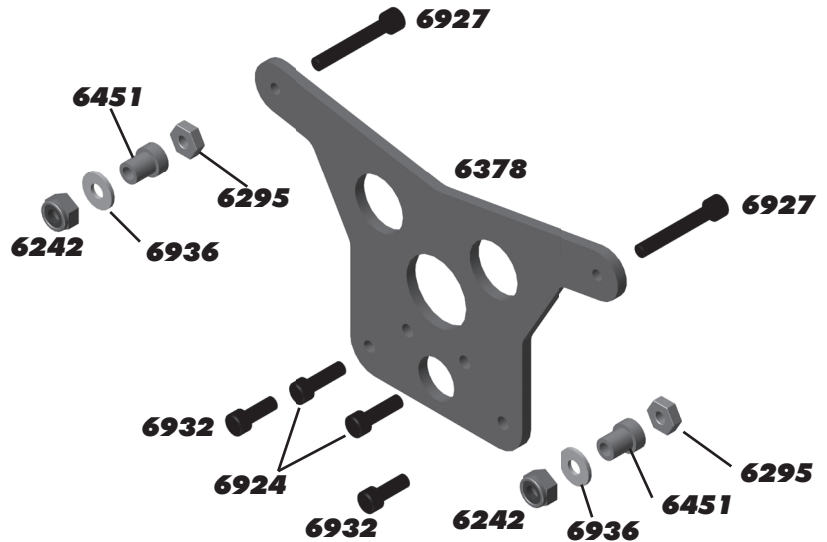

:: Wheels / Tires

6800	RC10 Rear Wheels	2
6815	RC10 Champion Rear Tires	2
6850	RC10 Front Wheels	2
6865	RC10 Edge Front Tires	2
6932	4-40 x 5/16" SHCS	6

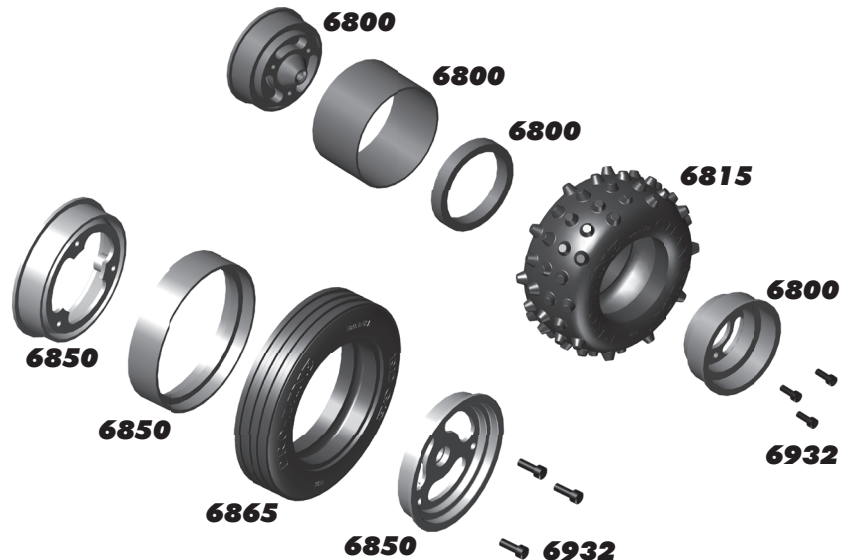

:: Rear Bulkhead

6271	Short Ballstud, Stainless Steel, .20	12
6280	8-32 x 1/2" Aluminum FHPS	16
6323	RC10 Rear Bulkhead	1
6326	RC10 Transmission Brace	1
6327	RC10 Wing Tubes	2
6331	RC10 Body Mounts (White)	2
6332	Body Clips	6
6925	4-40 x 1/2" SHCS	6
6936	#4 Washer, Aluminum	10

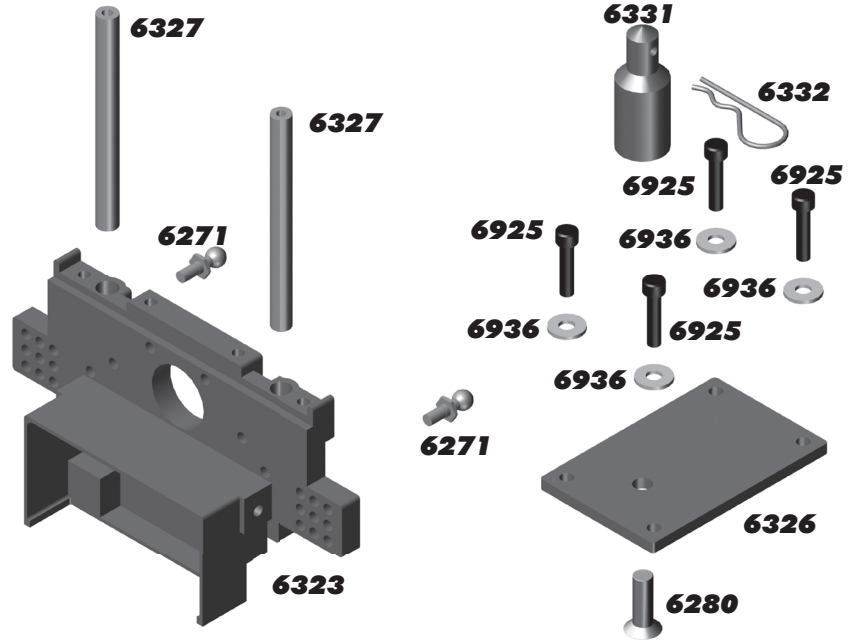

:: Transmission

6280	8-32 x 1/2" Aluminum FHPS	16
6285	4-40 x 1/4 SHCS	12
6299	E-Clip, 1/8"	12
6604	RC10 Transmission Fasteners Kit	1
6605	RC10 Transmission Case	1
6607	RC10 Motor Plate	1
6609	RC10 Drive Gear Pivot	1
6610	RC10 Idler Gear Pivot	1
6611	RC10 Spine Plate	1
6612	RC10 Axle Drive Gear	1
6613	RC10 Idler Gears w/Screws	2
6630	RC10 Oilite Bushing Set	1
6633	RC10 Felt Seal Set	2
6920	4-40 X 3/16" BHCS	6
6926	4-40 X 5/8" SHCS	6
6928	4-40 x 1" SHCS	6
7260	4-40 Small Pattern Plain Nut	12

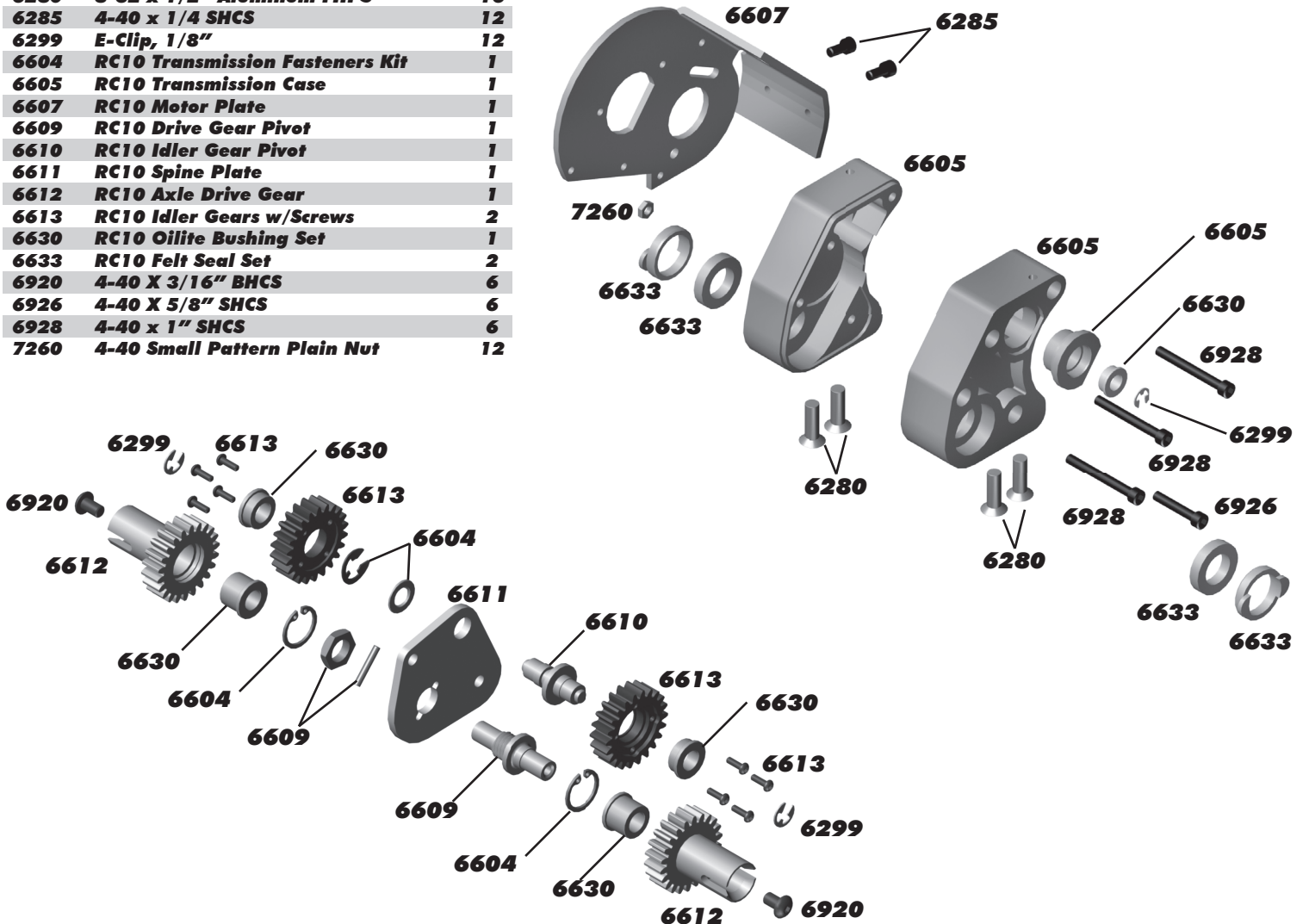

:: Chassis

3323	#8 Aluminum Thick Washer	12
6280	8-32 x 1/2" Aluminum FHPS	12
6288	4-40 X 1/4" BHCS	6
6300	RC10 Chassis	1
6310	RC10 Front Nose Plate	1
6320	RC10 Nose Brace Tubes	2
6331	RC10 Body Mounts (White)	2
6332	Body Clips	6
6917	4-40 X 3/8" BHCS	6
6926	4-40 X 5/8" SHCS	6
6931	8-32 x 1/4" Aluminum FHPS	6

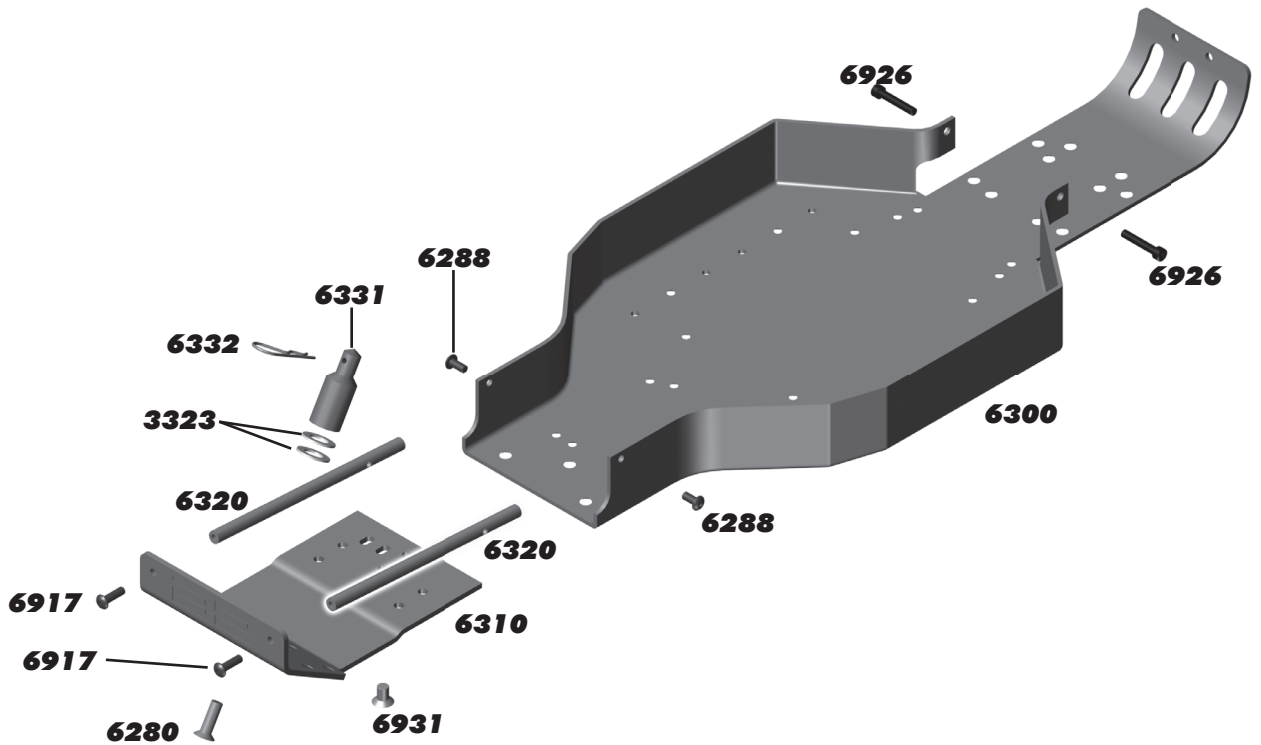

:: Lubes & Adhesives / Misc.

1105	FT Green Slime Shock Lube	1
1596	FT Locking Adhesive	1
1597	FT Tire Adhesive, medium	1
6588	Black Grease - 4cc	1
6636	Silicone Grease - 4cc	1
6727	Servo Tape	2



:: Body, Wing, and Decals

3834	AE Blue Embossed Logo Sticker	1
6121	Viper Buggy Body, clear	1
6160	Protech Buggy Body, clear - Kit	1
6180	RC10 Driver Figure, clear	1
6181	High Downforce Wing Kit, w/wire and buttons	1
6182	High Downforce Wing, 5 1/2"	1
6183	High Downforce Wing, 7"	1
6186	Large Wing	1
6187	RC10 Wing Kit	1
6188	Sprint Wing w/Side Dam	1
6190	Wing Mounts, Adjustable (wing-things)	2
6191	Wing Mount Kit	1
6192	RC10 Accessories (Wheel Knock Offs, Headlights)	1
6193	Wing Mounts, Aluminum	2
6193B	FT Wing Mounts, Aluminum (blue)	2
6866	RC10 Classic Decal Sheet	1
9788	Chassis Protective Tape	1

:: XP Electronics

29107	XP DS1903/S1903 Metal Gear Set	1
29125	S1903MG Servo	1
29133	XP DS1903 Digital Servo	1
29134	XP DS1903MG Digital Servo	1
29138	XP SC500-BL Brushless ESC	1
29139	XP SC900-BL Brushless ESC	1
29140	XP SC200 Brushed ESC	1
29141	XP SC450-BL Brushless ESC	1
29142	XP ESC Fan Option	1
29143	XP SC700-BL Brushless ESC	1
29144	XP SC1200-BL Brushless ESC	1
29166	XP DS1313 Digital Servo	1
29167	XP DS1015 Digital Servo	1
29168	XP DS1510MG Digital Servo	1
29209	Gear Set, DS1313	1
29210	Gear Set, DS1015	1
29211	Servo Case, DS1313/DS1015	1
29212	Accessory Pack, DS1313/DS1015	1
29214	TRS403-SSi 2.4GHz 4Ch Receiver	1
29215	XP2G 2.4GHz Radio System	1
29216	XP3G 2.4GHz Radio System	1
29250	XP DS1505 Digital Servo	1
29251	XP DS1505MG Digital Servo	1
29252	XP DS1505 Metal Gear Set	1
29253	XP DS1510 Metal Gear Set	1

:: Factory Team and Option Parts

897	Bearing, 1/4 X 3/8, flanged	2
1409	FT Titanium Turnbuckles, 1.00", blue	2
1736	FT Body Clips, Metallic Blue, Short	6
1779	FT Servo Mount, Blue Aluminum	2
4449	4-40 Aluminum Locknut, small pattern	5
6210	Front Block Carrier, 30° Caster	2
6220	Aluminum Front Inline Axle	2
6221	Inline Steering Block	2
6222	4-40/5-40 Nylon Locknut, black	8
6241	RC10 Front End Screw Set	1
6242	4-40 Steel Locknut	6
6259	Turnbuckle Tie Rod Set, black	1
6260	Turnbuckle, 1.00", black	2
6261	Turnbuckle, 1.25", black	2
6262	Turnbuckle, 1.65", black	2
6263	Turnbuckle, 2.06", black	2
6264	Turnbuckle, 1.375", black	2
6270	Short Ballstud, .20, Stainless Steel, short	2
6271	Short Ballstud Set, Stainless Steel, short	12
6272	Ballstud Dust Cover, foam	28
6273	Long Ballstud, .30, silver	2
6274	Ball Cup, molded	14
6325	Transmission Brace, black	1
6366	Rear Hub Carrier, 1.5° toe-in (per side), black	2
6390	Rear Wheel Knockoffs, (2 prong) white	4
6416	FT Gold Shock Shaft, 1.32" stroke	1
6419	FT Gold Shock Shaft, .56"	1
6431	Shock Kit, hard anodized, 1.32"	2
6434	Shock Kit, hard anodized, front, 0.56"	2
6435	Rear Shock Body, hard anodized, 1.32"	1
6438	Shock Body, hard anodized, 0.56"	1
6443	Bleeder Shock Cap, 1:10.	4
6463	1:10 Blank Shock Pistons	8
6465	Shock Piston, PTFE (1, 2, 3)	4ea
6473	Shock Bushing	4
6619	FT 1/8" Carbide Diff Balls	8
6902	Bearing, 3/16 X 5/16, flanged	2
6909	Bearing, 3/16 x 5/16	2
6910	FT Blue Aluminum Screw Kit, RC10	1
6937	FT 4-40 Aluminum Locknut, Blue Anodized	6
6943	FT 8-32 Blue Aluminum Locknut	6
8253	16T 48P Pinion Gear	1
8254	17T 48P Pinion Gear	1
8255	18T 48P Pinion Gear	1
8256	19T 48P Pinion Gear	1
8257	20T 48P Pinion Gear	1
8258	21T 48P Pinion Gear	1
8259	22T 48P Pinion Gear	1
8260	23T 48P Pinion Gear	1
8261	24T 48P Pinion Gear	1
8263	26T 48P Pinion Gear	1
8264	27T 48P Pinion Gear	1
8265	28T 48P Pinion Gear	1
8266	29T 48P Pinion Gear	1
8267	30T 48P Pinion Gear	1
8268	31T 48P Pinion Gear	1
8269	32T 48P Pinion Gear	1
8270	33T 48P Pinion Gear	1
8271	34T 48P Pinion Gear	1
8272	35T 48P Pinion Gear	1

:: Long Arm Conversion Parts

1401	FT Titanium Turnbuckle, 1.30", blue	2
1403	FT Titanium Turnbuckle, 1.65", blue	2
1405	FT Titanium Turnbuckles, 1.875", blue	2
6206	Front Suspension Arm, Wide, Composite, black	2
6231	Front Shock Tower	1
6418	FT Gold shock shaft, .71"	1
6433	Shock Kit, front, 0.71"	2
6460	Shock Shaft, .71"	1

:: Reedy Motors and ESC's

231	Sonic 540 Mach 2 21.5 Competition Brushless Motor	1
232	Sonic 540 Mach 2 17.5 Competition Brushless Motor	1
233	Sonic 540 Mach 2 13.5 Competition Brushless Motor	1
234	Sonic 540 Mach 2 10.5 Competition Brushless Motor	1
235	Sonic 540 Mach 2 9.5 Competition Brushless Motor	1
236	Sonic 540 Mach 2 8.5 Competition Brushless Motor	1
908	Replacement Rotor 540-SL	1
920	540-SL Brushless Motor 3300kV	1
921	540-SL Brushless Motor 3900kV	1
922	540-SL Brushless Motor 4900kV	1
923	540-SL Brushless Motor 6100kV	1
954	Sonic 540 Stock Rotor 12.3 x 24.2 (7.25)	1
955	Sonic 540 Stock Rotor 12.3 x 25.0 (7.25)	1
956	Sonic 540 Stock Rotor 12.5 x 25.0 (7.25)	1
957	Sonic 540 Modified Rotor 12.2 x 25.0 (5.0)	1
958	Sonic 540 Modified Rotor 12.5 x 25.0 (5.0)	1
965	Reedy 540-SL 3300kV/XP SC700-BL ESC Combo	1
966	Reedy 540-SL 3900kV/XP SC700-BL ESC Combo	1
967	Reedy 540-SL 4900kV/XP SC700-BL ESC Combo	1
983	Reedy 540-SL 3300kV/XP SC1200-BL ESC Combo	1
984	Reedy 540-SL 3900kV/XP SC1200-BL ESC Combo	1
985	Reedy 540-SL 4900kV/XP SC1200-BL ESC Combo	1
986	Reedy 540-SL 6100kV/XP SC1200-BL ESC Combo	1
987	Sonic 540 Modified Rotor 13.0 x 25.0 (5.0)	1

**:: Reedy Motors
(not recommended for RC10 Classic)**

237	Sonic 540 Mach 2 8.0 Competition Brushless Motor	1
238	Sonic 540 Mach 2 7.5 Competition Brushless Motor	1
239	Sonic 540 Mach 2 7.0 Competition Brushless Motor	1
240	Sonic 540 Mach 2 6.5 Competition Brushless Motor	1
241	Sonic 540 Mach 2 6.0 Competition Brushless Motor	1
242	Sonic 540 Mach 2 5.5 Competition Brushless Motor	1
243	Sonic 540 Mach 2 5.0 Competition Brushless Motor	1
244	Sonic 540 Mach 2 4.5 Competition Brushless Motor	1
245	Sonic 540 Mach 2 4.0 Competition Brushless Motor	1
246	Sonic 540 Mach 2 3.5 Competition Brushless Motor	1

:: Reedy Accessories

247	Sonic 540 Mach 2 Sensor w/bearing	1
248	Sonic 540 Mach 2 Steel Bearing Set	1
249	Sonic 540 Mach 2 Ceramic Bearing Set	1
250	Sonic 540 Mach 2 Insulator Set	1
604	526-S AC/DC 2S-6S LiPo/LiFe Charger	1
606	Charge Harness 2S Saddle Pack 4mm	1
607	Charge Harness 2S Standard Pack 4mm	1
609	TAM to DEANS® charge adapter	1
610	447-S AC/DC NiMH Peak Charger	1
651	Battery Bars (8)	1
654	4.0mm plugs (2M, 2F)	1
655	4.0mm plugs (2M, 10F)	1
656	4.0mm plugs (10F)	1
658	4.0mm plugs (10M)	1
659	4.0mm plugs (30M)	1
660	3.5mm plugs (3M, 3F)	1
661	3.5mm plugs (10F)	1
663	3.5mm plugs (10M)	1
664	3.5mm plugs (30M)	1
716	Reedy 09 Decal Set	1
962	Sonic 540 Case Screws (3 pcs.)	1
974	540-SL/550-SL Steel Bearing Set	1
975	540-SL/550-SL Ceramic Bearing Set	1
978	Flat Sensor Wire 70mm	1
979	Flat Sensor Wire 110mm	1
980	Flat Sensor Wire 150mm	1
981	Flat Sensor Wire 200mm	1
982	Flat Sensor Wire 270mm	1
992	Sonic 540 Rotor Spacers	1

:: Qualifier Series Vehicles

7052	Pro Lite 4x4 RTR, 1/10 Scale (ready-to-run)	1
20111	Rival Mini Monster Truck 1/18 Scale (ready-to-run)	1
20119	APEX Mini Touring RTR	1
20510	RIVAL Electric Monster Truck RTR, 1/8 Scale (ready-to-run)	1
30112	APEX Touring V-Type, 1/10 Scale (ready-to-run)	1

:: 1/18 Kits and RTR's

20103	RC18B2 - RC18T2 Team Kit	1
20121	SC18 RTR Brushless (ready-to-run)	1

:: Reedy Batteries

302	AA Alkaline 1.5V (4)	1
309	LiPo 65C 7000mAh 7.4V	1
602	LiPo 65C 4100mAh 7.4V Shorty	1
637	LiPo TX Battery - M11X 2500mAh 7.4V	1
681	Wolfpack 2400mAh 7.2V w/DEANS® connector	1
682	Wolfpack 3000mAh 7.2V w/DEANS® connector	1
683	Wolfpack 3600mAh 7.2V w/DEANS® connector	1
684	Wolfpack 4200mAh 7.2V w/DEANS® connector	1
689	R-Power 1700mAh 7.2V w/TAM connector	1
693	Wolfpack 2400mAh 7.2V w/TAM connector	1
694	Wolfpack 3000mAh 7.2V w/TAM connector	1
695	Wolfpack 3600mAh 7.2V w/TAM connector	1
700	Wolfpack 4200mAh 7.2V w/TAM connector	1
730	Wolfpack LiPo 3000mAh 7.4V 25C w/DEANS®	1
731	Wolfpack LiPo 3300mAh 7.4V 35C w/DEANS®	1
732	Wolfpack LiPo 3400mAh 7.4V 35C w/DEANS®	1
734	Wolfpack LiPo 6500mAh 7.4V 25C w/DEANS®	1
735	Wolfpack LiPo 3900mAh 11.1V 35C w/DEANS®	1
736	Wolfpack LiPo 5000mAh 7.4V 25C	1
738	Wolfpack LiPo 3800mAh 7.4V 25C Shorty	1

:: 1/12, 1/10 Kits and RTR's

2042	Nitro TC3 RTR Plus (ready-to-run)	1
4020	FT 12R5.2 Kit	1
6001	RC10 Classic Kit	1
7025	FT RC10T4.2 Kit	1
7029	SC10 Associated/RC10.com Truck RTR (ready-to-run)	1
7030	SC10 KMC Wheels Race Truck RTR (ready-to-run)	1
7038	FT SC10.2 Kit	1
7039	RC10T4.2 RS RTR 2.4GHz Brushless (ready-to-run)	1
7046	SC10 RS RTR, Lucas Oil (ready-to-run)	1
7048	SC10 RS RTR, Pro Comp (ready-to-run)	1
7049	SC10 RS RTR, Rockstar/Makita (ready-to-run)	1
7050	SC10 RS RTR, Hart and Huntington (ready-to-run)	1
7093	SC10GT RTR (ready-to-run)	1
8020	FT RC10R5 Kit	1
8022	FT RC10R5.1 Kit	1
9040	FT RC10B4.1 Worlds Kit	1
9041	FT RC10B4.2 Kit	1
9042	RC10B4.2 RS RTR 2.4GHz Brushless (ready-to-run)	1
9050	SC10B RS RTR (ready-to-run)	1
9062	FT B44.2 4WD Buggy Kit	1
30101	TC4 Club Racer 4WD Touring Car Race Roller	1
30108	FT TC6.1 WC 4WD Touring Car Kit	1
90005	SC10 4x4 Lucas Oil RTR (ready-to-run)	1
90006	SC10 4x4 Pro Comp RTR (ready-to-run)	1
90010	SC10 4x4 FT Kit	1

:: 1/8 Kits and RTR's

20501	MGT 4.60 SE RTR (ready-to-run)	1
20502	MGT 8.0 Nitro RTR (ready-to-run)	1
20503	Limited Edition MGT 4.60 Nitro RTR, w/flag body (ready-to-run)	1
20504	Limited Edition MGT 8.0 Nitro RTR, w/flag body (ready-to-run)	1
80906	RC8.2 Nitro Buggy FT Kit	1
80907	RC8.2e Electric Buggy FT Kit	1
80908	RC8.2e Electric Buggy RTR (ready-to-run)	1
80909	RC8.2RS Nitro Buggy RTR (ready-to-run)	1
80912	RC8T Championship Edition	1
80933	SC8.2e Short Course Race Truck, Rockstar/Makita Electric RTR (ready-to-run)	1
80934	SC8.2e Short Course Race Truck, Slick Mist Electric RTR (ready-to-run)	1

:: Tools

1111	FT Turnbuckle Wrench	1
1449	FT Off Road Ride Height Gauge	1
1541	FT Hex Driver Set, (7 pcs)	1
1542	FT .050" Silver Hex Driver	1
1543	FT 1/16" Black Hex Driver	1
1544	FT 1.5mm Purple Hex Driver	1
1545	FT 5/64" Blue Hex Driver	1
1546	FT 3/32" Gold Hex Driver	1
1547	FT 2.5mm Green Hex Driver	1
1548	FT 3mm Red Hex Driver	1
1553	FT Phillips Silver Screwdriver	1
1554	FT Silver Spring Hook Tool	1
1561	FT Nut Driver Set, (6 pcs)	1
1562	FT 3/16" Black Nut Driver	1
1563	FT 1/4" Red Nut Driver	1
1564	FT 5.5mm Red Nut Driver	1
1565	FT 11/32" Green Nut Driver	1
1567	FT 8mm Gold Nut Driver	1
1589	FT 5/64" Blue Ball Hex Driver	1
1590	FT 3/32" Gold Ball Hex Driver	1
1592	FT Ball Hex Driver Set, (3 pcs)	1
1655	FT 8-Piece 1/4" Hex Drive Set	1
1656	FT 1/4" Hex Drive Handle, without tips	1
1657	FT 1/4" Hex Drive .050" Tip	1
1658	FT 1/4" Hex Drive 1/16" Tip	1
1659	FT 1/4" Hex Drive 5/64" - 2.0mm Tip	1
1660	FT 1/4" Hex Drive 3/32" Tip	1
1661	FT 1/4" Hex Drive 1.5mm Tip	1
1662	FT 1/4" Hex Drive 2.5mm Tip	1
1663	FT 1/4" Hex Drive 3/16" Nut Driver Tip	1
1664	FT 1/4" Hex Drive 1/4" Nut Driver Tip	1
1665	FT 1/4" Hex Drive 11/32" Nut Driver Tip	1
1666	FT 1/4" Hex Drive 5.5mm Nut Driver Tip	1
1667	FT 1/4" Hex Drive 7.0mm Nut Driver Tip	1
1668	FT 1/4" Hex Drive 8.0mm Nut Driver Tip	1
1669	FT 1/4" Hex Drive 5/64" - 2.0mm Ball End Tip	1
1670	FT 1/4" Hex Drive 3/32" Ball End Tip	1
1671	FT 1/4" Hex Drive Standard Screwdriver Tip	1
1672	FT 1/4" Hex Drive Phillips Screwdriver Tip	1
1673	FT 1/4" Hex Drive 2.5mm Ball End Tip	1
1674	FT 1/4" 5 Piece Power Tool Tips Set (5/64-2.0mm, 1.5mm, 2.5mm, 5/64"- 2.0mm ball, 2.5mm ball)	1
1719	FT Camber + Track Width Tool	1
1737	FT Body Scissors	1
3718	12 Inch Nylon Wire Ties	12
3719	6 Inch Nylon Wire Ties	12
3720	8 Inch Nylon Wire Ties	12
3987	FT Droop Gauge	1
6429	Shock Building Tool	1
6956	Molded Tools, Set	1
7494	V2 Stamped Multi-tool	1
7709	4 Inch Nylon Wire Ties	12

:: RePlay Cameras

RP001	Replay XD1080 Complete Camera System	1
RP002	Replay XD720 Complete Camera System	1
RP021	Replay XD1080 Lens Bezel Kit	1
RP022	Replay XD1080 Clear Lens Cover	1
RP023	Replay XD1080 Lens Bezel & Rear Cap O-Ring	1
RP029	Replay XD1080 HDMI to Mini-HDMI	1
RP030	Replay XD1080 Mini 8-pin USB Charge Data Cable	1
RP032	USB DC Car Charger 1A Stubby	1
RP033	USB DC Car Charger 500mAh	1
RP034	Micro SDHC USB Reader	1
RP036	3M VHB 4991 Mount Adhesive for SnapTray	1
RP038	3M VHB 5962 Mount Adhesive for SnapTray	1
RP041	Replay XD Suction Cup Arm Mini Clamp	1
RP042	Replay XD Suction Cup Short Arm Base	1
RP043	Replay XD Skateboard Mount	1
RP044	Replay XD VHB SnapTray, Convex	1
RP045	Replay XD VHB SnapTray, Flat	1
RP046	Au Plug for Universal DC Wall Charger	1
RP047	Eu Plug for Universal DC Wall Charger	1
RP048	Uk Plug for Universal DC Wall Charger	1
RP049	Universal USB DC Wall Charger 1A	1
RP054	Replay ReView Field Monitor	1

:: Apparel

SP36**	Reedy 09' Black T-Shirt (M, XL, 2XL)	1
SP37**	Reedy 2012 T-shirt - Black (S, M, L, XL, 2XL, 3XL)	1
SP38	Reedy Trucker Hat	1
SP39	Reedy Patch	1
SP66**	Stencil Blue T-Shirt (S, M, L, XL, 2-6XL)	1
SP67**	AE Stencil Gray Sweatshirt (S, M, L, XL, 2XL, 3XL)	1
SP68**	AE Stencil Blue T-Shirt (M, L, XL)	1
SP69**	AE 26 Time World Championship T-Shirt, Black (S, M, L, XL, 2XL, 3XL)	1
SP70**	Associated Windbreaker (XL)	1
SP71**	Associated Winter Jacket (M, L, XL)	1
SP73**	AE Long Sleeve T-Shirt (S, M, L, XL, 2XL)	1
SP74**	AE White T-Shirt (S, M, L, XL, 2XL, 3XL, 4XL)	1
SP75**	AE Blue T-Shirt (S, M, L, XL, 2XL, 4XL, 6XL)	1
SP76**	AE Black T-Shirt (S, M, L, XL, 2XL, 3XL)	1
SP77**	AE 2012 T-Shirt, Blue (S, M, L, XL, 2XL, 3XL)	1
SP78**	AE 2012 T-Shirt, White (S, M, L, XL, 2XL, 3XL)	1
SP79**	AE 2012 T-Shirt, Black (S, M, L, XL, 2XL, 3XL)	1
SP84**	Reedy 3D T-Shirt, Black (S, M, L, XL, 2XL, 3XL)	1
SP85**	Reedy Zip Hoodie, Black (S, M, L, XL, 2XL, 3XL)	1
SP86**	Reedy Girl's 3D T-Shirt, Black (S, M, L, XL)	1
SP87**	AE 2013 Zip Hoodie (S, M, L, XL, 2XL, 3XL)	1
SP411S	AE Hat 11' Flat Bill Black S/M	1
SP411L	AE Hat 11' Flat Bill Black L/XL	1
SP413S	26 Time World Championship Hat S/M	1
SP413L	26 Time World Championship Hat L/XL	1
SP416	Associated Car Carrier Bag, Medium	1
SP417	1/10 FT Motor Bag	1
SP418	Factory Team 1/10 Car Carrier Bag	1
SP420**	AE Pit Gloves (L, XL)	Pr.
SP421S	AE 2012 Hat, Black, Flat Bill, S/M	1
SP421L	AE 2012 Hat, Black, Flat Bill, L/XL	1
SP422S	AE 2012 Hat, Black, Curved Bill, S/M	1
SP422L	AE 2012 Hat, Black, Curved Bill, L/XL	1
SP423S	AE 2012 Hat, White, Flat Bill, S/M	1
SP423L	AE 2012 Hat, White, Flat Bill, L/XL	1
SP424S	AE 2012 Hat, White, Curved Bill, S/M	1
SP424L	AE 2012 Hat, White, Curved Bill, L/XL	1
715	Reedy 2009 Track Banner	1
110684	Team Associated Track Banner	1

TEAM ASSOCIATED RC10 SETUP SHEET

Driver: _____ Date: _____
 Track: _____ Event: _____
 Conditions: Indoor Outdoor Temp. _____ Rev.1

Steering / Servo Horn

Steering Rack

Servo Horn:
AE #89007

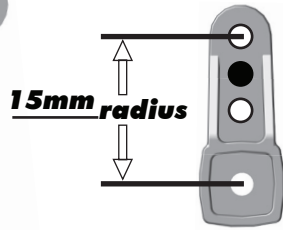
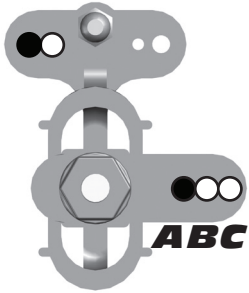

Ride Height / Wheelbase

Front Ride Height:

Rear Ride Height:



Front Suspension

Camber: -1°

Toe: 0°

Caster:

Steering Block:
Inline
Trailing

15°
30°

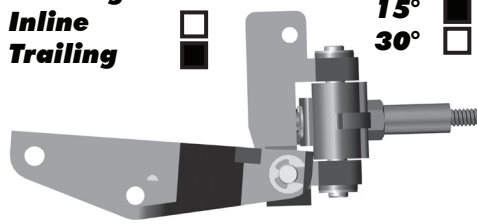
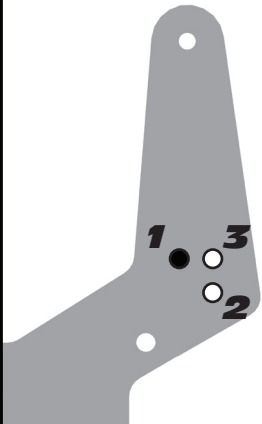

Rear Suspension

Camber: -1°

Rear Hub Carriers:
0°
1.5°

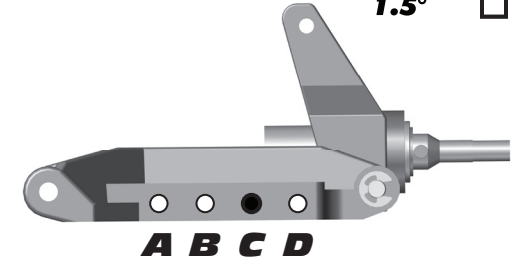
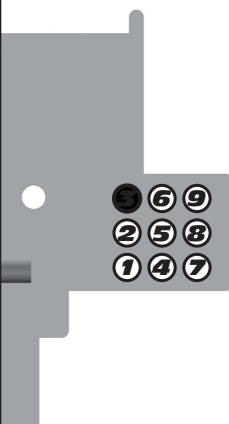

Front Shocks

Spring: Silver Piston: #2
 Shock Oil: 30wt Limiter: 0

Rear Shocks

Spring: Silver Piston: #2
 Shock Oil: 30wt Limiter: 2

Electronics

Motor & Wind: _____
 Pinion: _____ Spur Gear: 81T
 Batteries: _____

Radio / ESC Settings

Radio: _____
 Throttle / Brake e.p.a.: _____
 Throttle / Brake expo: _____
 Servo: _____ Steering Expo: _____
 ESC: _____
 ESC Settings: _____

Weight

Battery Placement: Standard, full length
 Ballast Weight: _____
 Notes: _____

Other

Body Type: ProTech
 Wing Type: RC10 Small Wing

Front Tires

Tire: Pro Line Edge
 Compound: _____
 Insert: N/A Wheel: Stock

Rear Tires

Tire: Pro Line Champion
 Compound: _____
 Insert: N/A Wheel: Stock

Race and Vehicle Comments







Qualify: _____ Main: _____ Finish: _____ TQ: _____
 Comments: _____

Track Info

Surface:	Traction:	Conditions:	Moisture:
Dirt <input type="checkbox"/>	Low <input type="checkbox"/>	Grooved <input type="checkbox"/>	Wet <input type="checkbox"/>
Carpet <input type="checkbox"/>	Med <input type="checkbox"/>	Dusty <input type="checkbox"/>	Damp <input type="checkbox"/>
Astro <input type="checkbox"/>	High <input type="checkbox"/>	Smooth <input type="checkbox"/>	Dry <input type="checkbox"/>
Multi <input type="checkbox"/>		Bumpy <input type="checkbox"/>	
		Hard Pack <input type="checkbox"/>	
		Loamy <input type="checkbox"/>	

:: Hardware - 1:1 Scale View



Cap Head (shcs)

-  **4-40x1/4 (6285)**
-  **4-40x5/16" (6932)
(4145, aluminum)**
-  **4-40x3/8 (6924)
w/hole (6929)**
-  **4-40x1/2 (6925)
w/hole (6916)**
-  **4-40x5/8 (6926)**
-  **4-40x3/4 (6927)**
-  **4-40x1 (6928)**





Flat Head (fhcs)

-  **4-40x3/8 (6292)**
-  **4-40x1/2 (6922)**



Flat Head (fhps)

-  **8-32x1/4 (6931)**
-  **8-32x1/2 (6280)**
-  **8-32x7/8 (6281)**

Button Head (bhcs)

-  **0-80x3/16 (6613)**
-  **4-40x3/16 (6920)**
-  **4-40x1/4 (6288)**
-  **4-40x3/8 (6917)**
-  **3x6mm (31531)**



Bushings

-  **Oillite Bushing Set (6630)
1/4 x 3/8 x 1/8 Flanged**
-  **3/16 x 5/16 x 1/8 Flanged**
-  **3/16 x 5/16 x 1/4 Flanged**

Set Screws

-  **4-40x1/8 (6951)**
-  **4-40x5/16 (4436)**







Clips

-  **E-clip 1/8 (6299)**
-  **Bowed E-Clip (6604)**

Diff Balls







-  **1/8 Diff Balls (6626)**

Nuts (lock/plain)

-  **4-40 Steel Locknut (6242)**
-  **4-40 Nuts (6295)**
-  **4-40 Small Pattern
Plain Nut (7260)**
-  **5-40 Diff Locknut (6629)**
-  **8-32 Nylon Nut, White (6282)**
-  **8-32 Steel Locknut (6952)**

Notes:

Shims and Washers

-  **Dogbone spacer (6372)**
-  **.030 Nylon Spacer (4187)**
-  **#4 Washer (6936)**
-  **1/4" Axle Shim (6373)**
-  **Diff Thrust Washers (6627)**
-  **5mm x 9.5mm 0.17mm (6604)**
-  **#8 Aluminum Thick
Washer (3323)**

TEAM ASSOCIATED RC10 SETUP SHEET

Driver: _____ Date: _____
 Track: _____ Event: _____
 Conditions: Indoor Outdoor Temp. _____ Rev.1

Steering / Servo Horn

Steering Rack

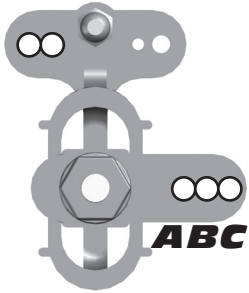

Servo Horn:

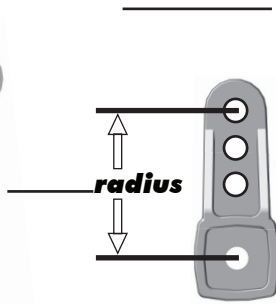

Ride Height / Wheelbase

Front Ride Height:

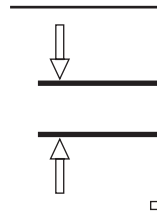

Rear Ride Height:

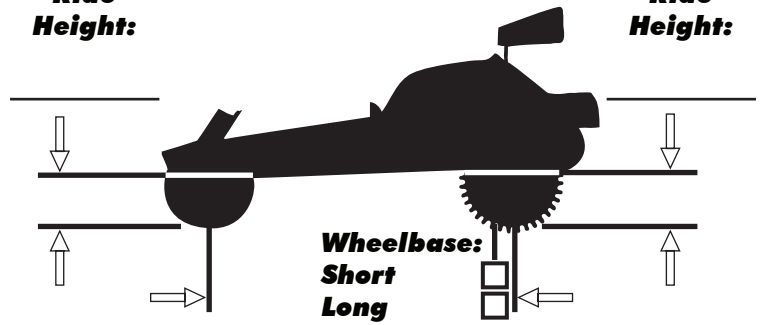

Front Suspension

Camber: _____

Toe: _____

Caster:

15°
30°

Steering Block:
 Inline
 Trailing

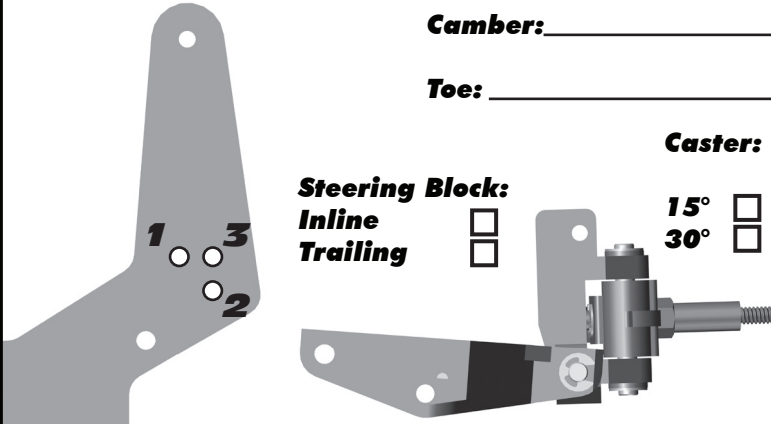

Rear Suspension

Camber: _____

Rear Hub Carriers:
 0°
 1.5°

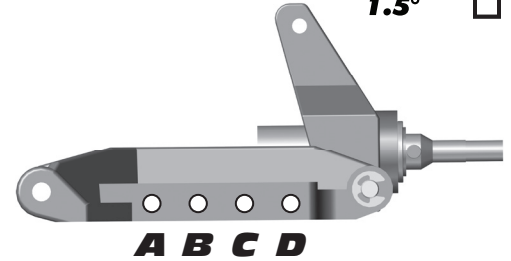

Front Shocks

Spring: _____ Piston: _____
 Shock Oil: _____ Limiter: _____

Rear Shocks

Spring: _____ Piston: _____
 Shock Oil: _____ Limiter: _____

Electronics

Motor & Wind: _____
 Pinion: _____ Spur Gear: _____
 Batteries: _____

Radio / ESC Settings

Radio: _____
 Throttle / Brake e.p.a.: _____
 Throttle / Brake expo: _____
 Servo: _____ Steering Expo: _____
 ESC: _____
 ESC Settings: _____

Weight

Battery Placement: _____
 Ballast Weight: _____
 Notes: _____

Other

Body Type: _____
 Wing Type: _____

Front Tires

Tire: _____
 Compound: _____
 Insert: _____ Wheel: _____

Rear Tires

Tire: _____
 Compound: _____
 Insert: _____ Wheel: _____

Race and Vehicle Comments

Qualify: _____ Main: _____ Finish: _____ TQ: _____
 Comments: _____

Track Info

Surface:	Traction:	Conditions:	Moisture:
Dirt <input type="checkbox"/>	Low <input type="checkbox"/>	Grooved <input type="checkbox"/>	Wet <input type="checkbox"/>
Carpet <input type="checkbox"/>	Med <input type="checkbox"/>	Dusty <input type="checkbox"/>	Damp <input type="checkbox"/>
Astro <input type="checkbox"/>	High <input type="checkbox"/>	Smooth <input type="checkbox"/>	Dry <input type="checkbox"/>
Multi <input type="checkbox"/>		Bumpy <input type="checkbox"/>	
		Hard Pack <input type="checkbox"/>	
		Loamy <input type="checkbox"/>	



**Associated Electrics, Inc.
26021 Commercentre Dr.
Lake Forest, CA 92630 USA**

<http://www.TeamAssociated.com>

<https://www.RC10.com>

https://twitter/Team_Associated

<https://bit.ly/AEonFacebook>

call: (949) 544-7500 - fax: (949) 544-7501

**Check out the following web sites for all of our kits,
current products, new releases, setup help, tips, and racing info!**

www.TeamAssociated.com - www.RC10.com