

B44

:: Instruction Manual



1/10th Scale Electric Powered 4WD Racing Buggy

:: Introduction

Thank you for purchasing this Team Associated product. This manual contains instructions and tips for building and maintaining your new B44. Please take a moment to read through it and familiarize yourself with these steps.

:: B44 Features

- 3mm woven carbon fiber shock towers
- 2.5mm woven carbon fiber chassis
- Rear hub uses larger bearing for improved durability
- Center, double-sided adjustable slipper drive assembly for improved drivetrain durability
- Blue aluminum center bulkhead cap with molded bearing inserts
- Blue FT Titanium Turnbuckles
- Blue FT aluminum shock bushings
- Blue FT aluminum servo mounts
- Blue FT aluminum battery strap thumbscrews
- Hard anodized threaded shock bodies
- FT AE Gold shock shafts
- Hardened steel CVA's with AE cross-pin retaining clips
- Ball bearing steering
- Shaft drive for unparalleled acceleration
- Used B4 rear arms, rear wheels, rear hub spur gears, slipper plates & slipper pads

:: Additional

Your B44 Buggy comes unassembled and requires the following items to complete:

Items:

- R/C two channel surface frequency radio system
- 6 cell battery pack
- Battery charger (we recommend a peak detection charger)
- Electronic Speed Control (ESC)
- R/C electric motor
- Pinion gear, size to be determined by type and wind of motor you will be using
- AA-Size Batteries for Transmitter
- Lexan Specific Spray Paint

Tools Included:

- Allen wrenches, .050", 1/16", 3/32", 5/64" (AE Pt#6950)
- Molded tools (AE Pt#6956)
- Camber gauge (AE Pt#1719)

Tools Suggested:

- Hex Wrenches
- Hobby Knife
- Needle Nose Pliers
- Lexan Scissors (AE Pt#1737)
- Reamer/Hole Punch
- CA Glue (AE Pt#1597)

:: Support**Associated Electrics, Inc.**

26021 Commercentre Dr.

Lake Forest, CA 92630

Tel: 949.544.7500 • Fax: 949.544.7501

<http://www.TeamAssociated.com> • <http://www.RC10.com>

:: Front and Rear Differentials

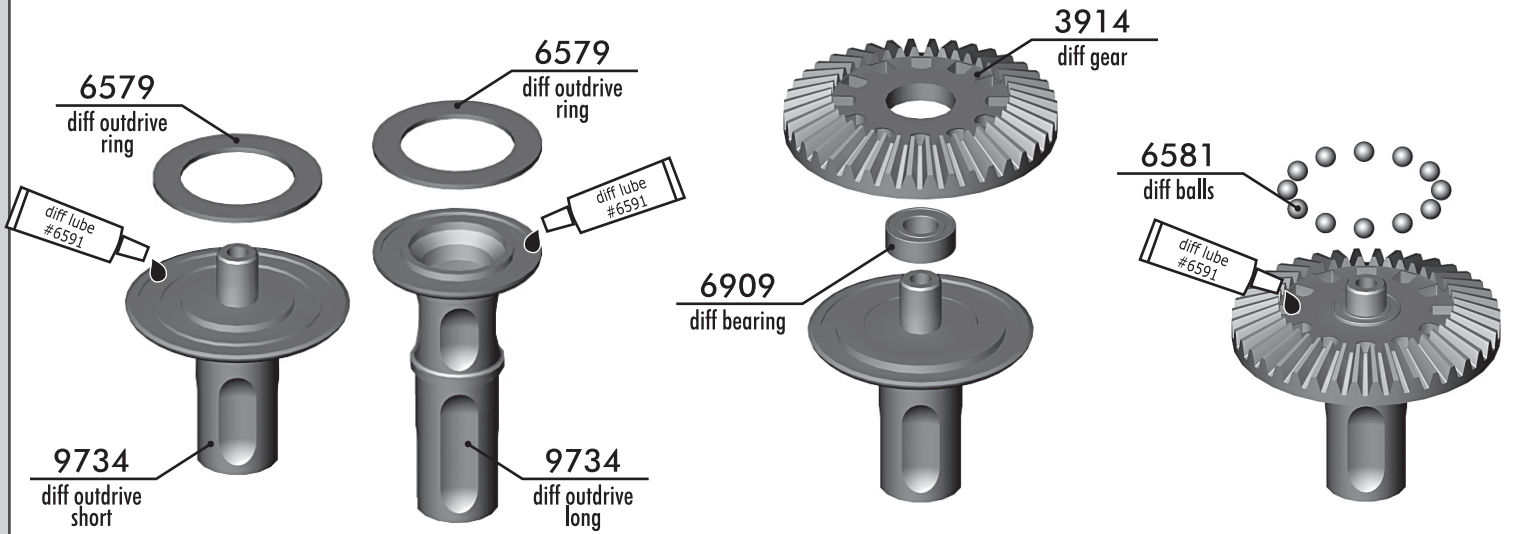

:: Front and Rear Differentials (cont.)

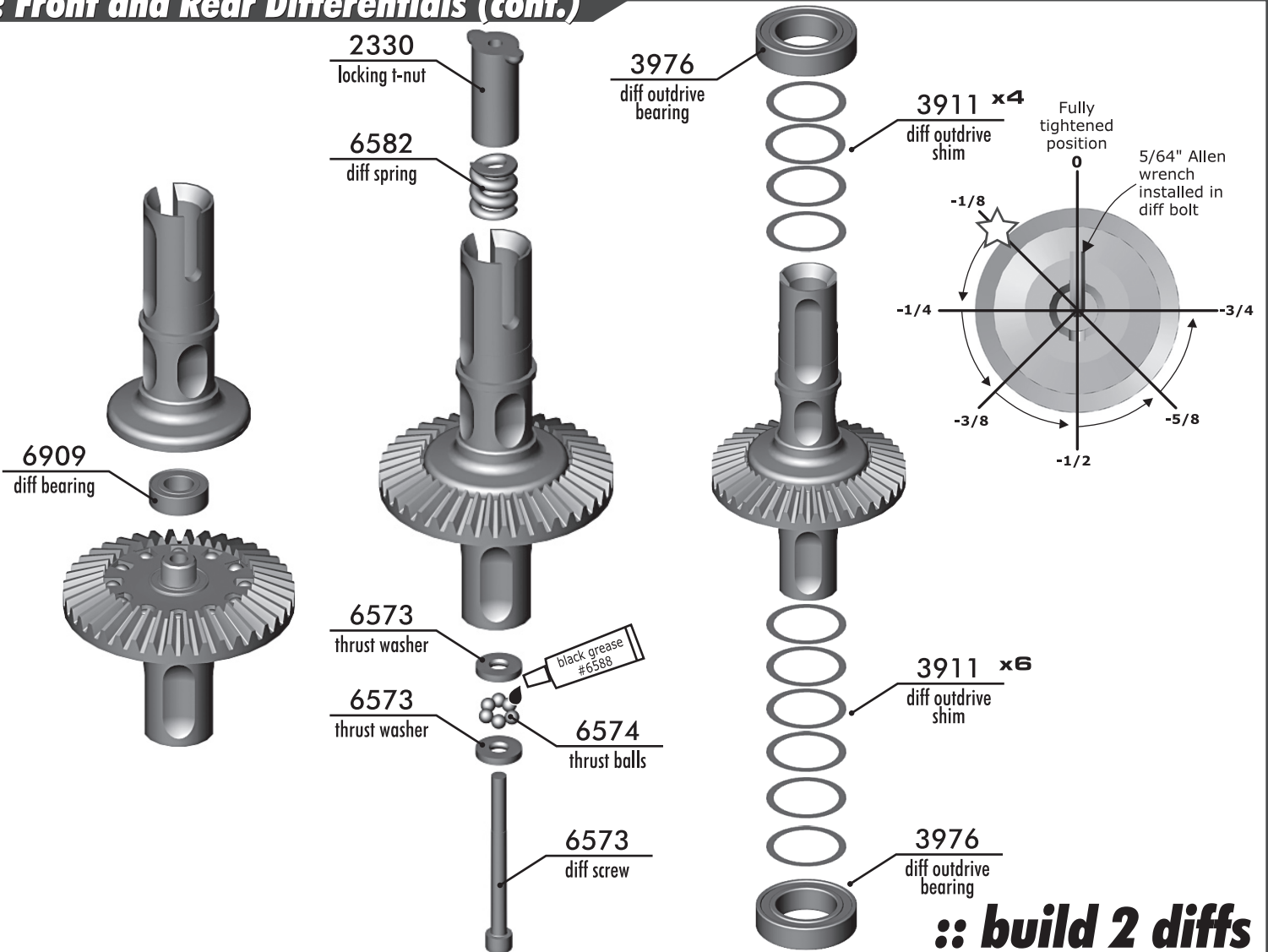

:: Center Slipper

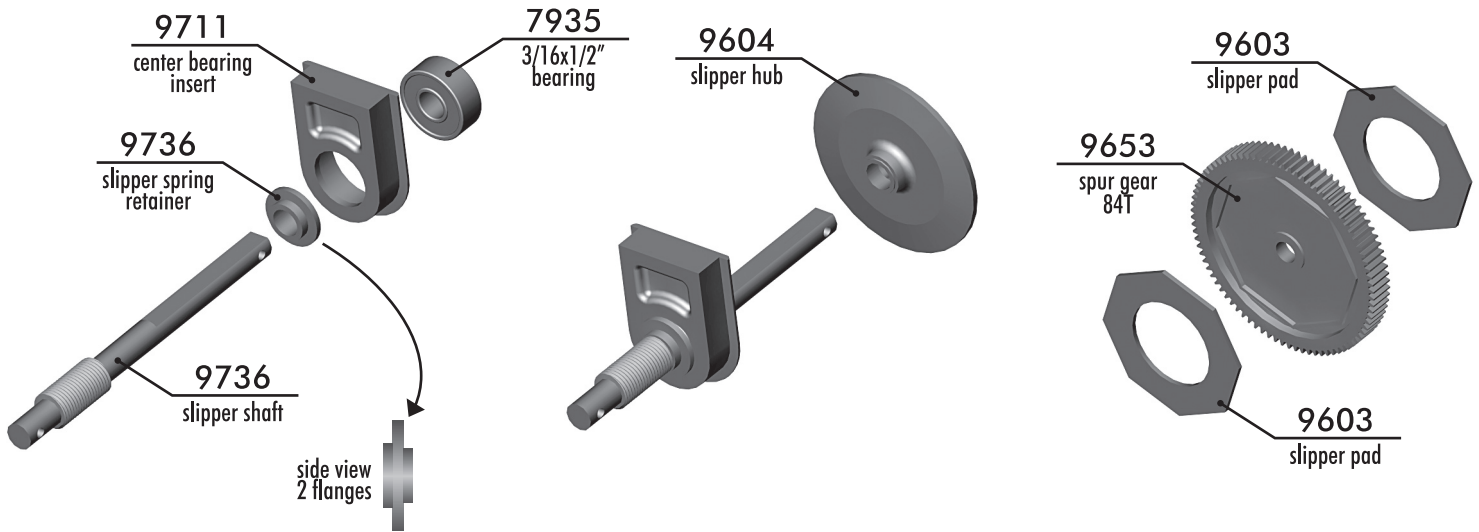

:: Center Slipper (cont.)

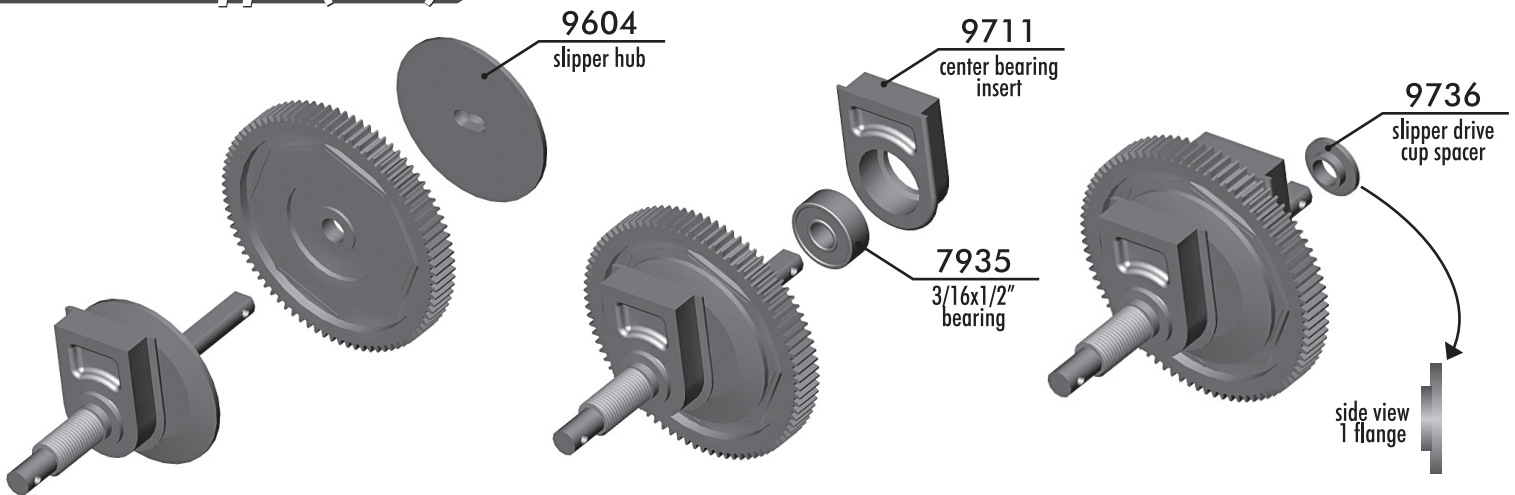

:: Center Slipper (cont.)

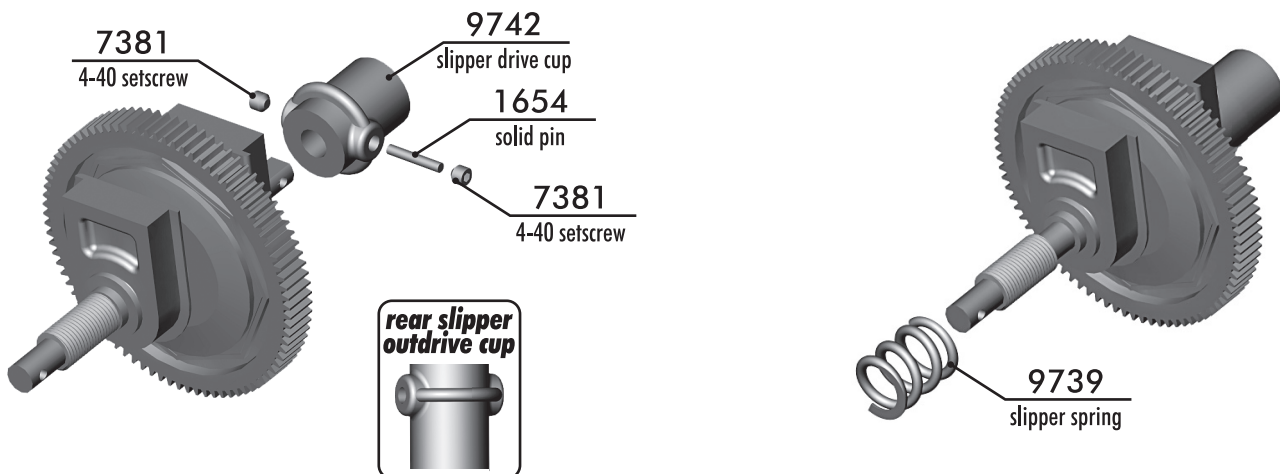

:: Center Slipper (cont.)

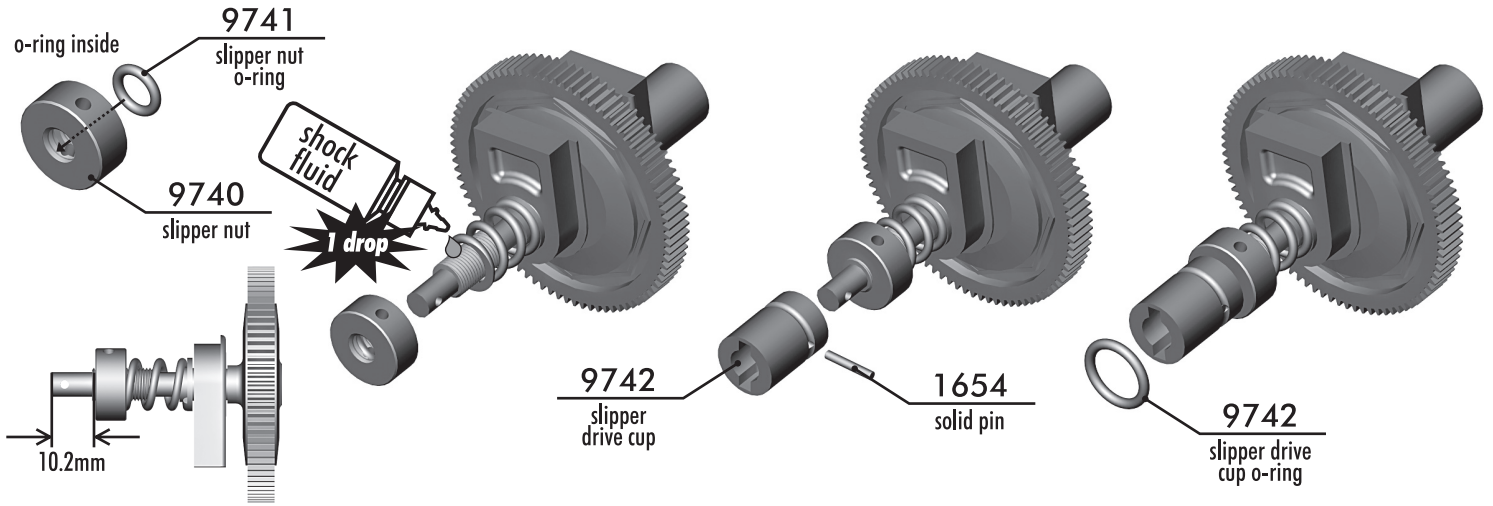

:: Shocks

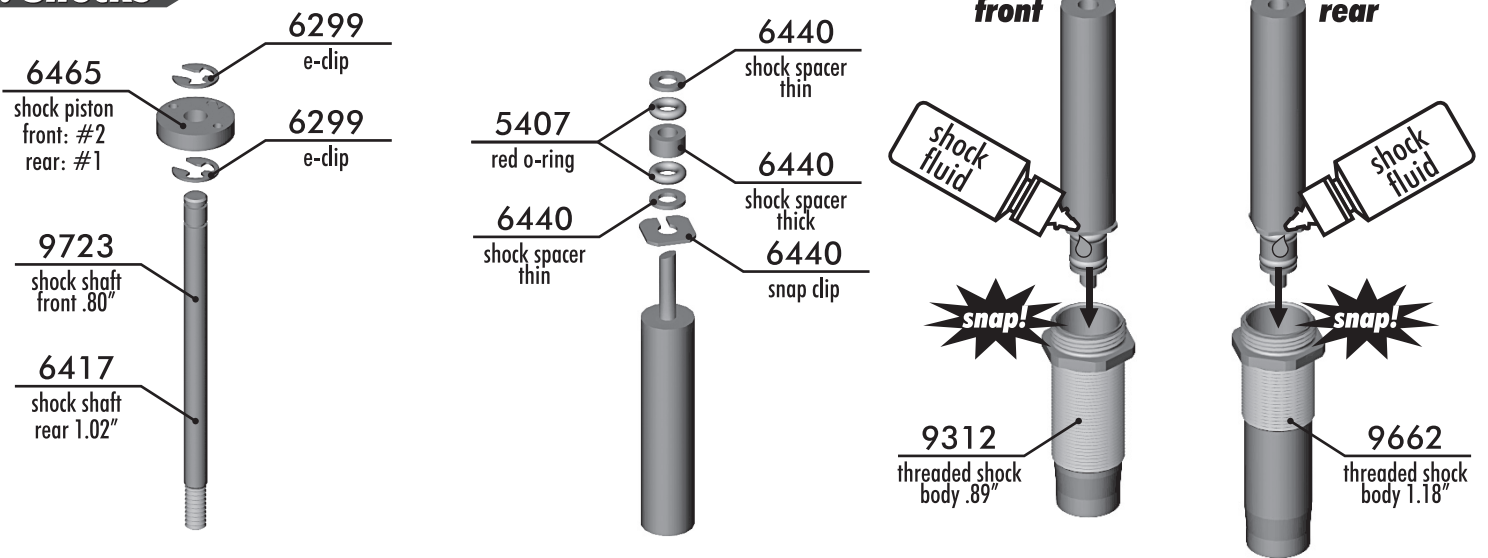

:: Shocks (cont.)

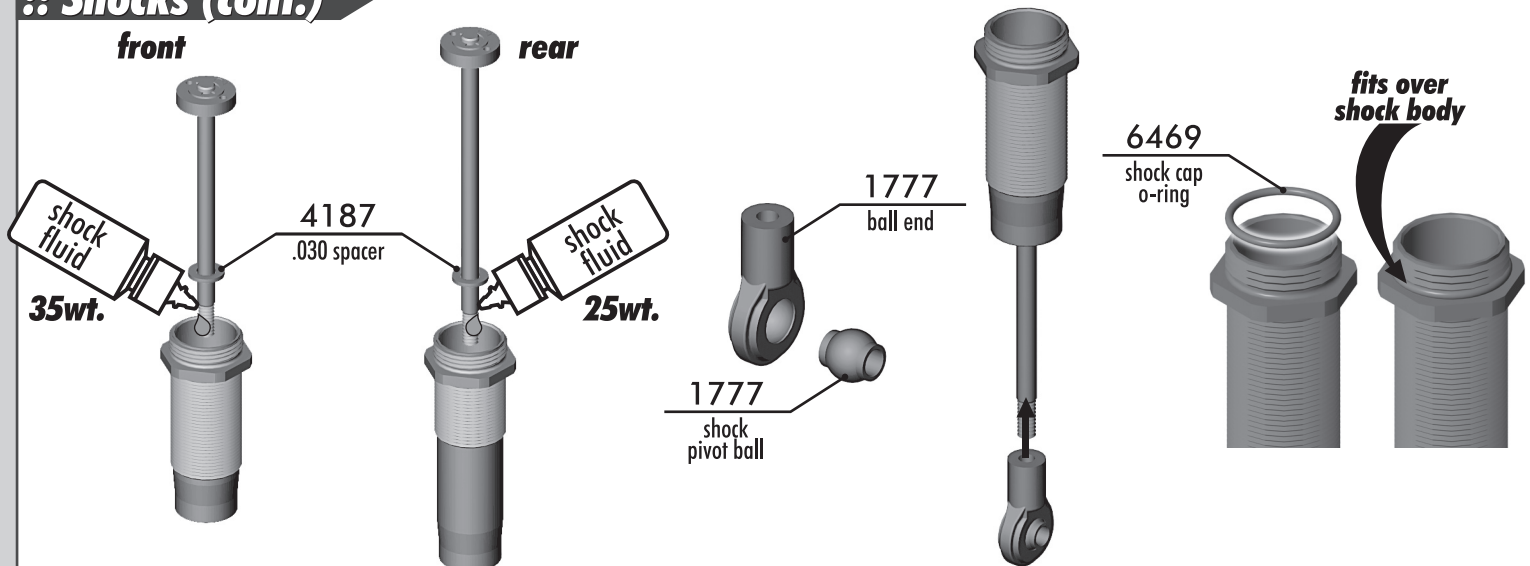

:: Shocks (cont.)

fill to top with shock oil



move shaft up and down to remove air bubbles

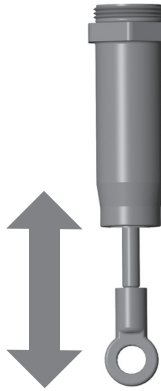

fill to top with shock oil



push the shaft in. shock oil will crown

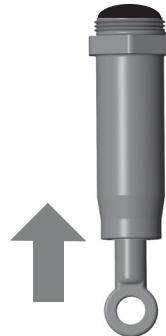

retain shock oil as you screw cap on



6428 shock cap

move the shock shaft in and out a few times. push it all the way in.

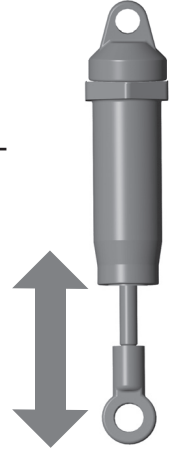

:: Shocks (cont.)

the shaft should push itself out 1/4" to 3/8".



:: bleeding the shocks

if the shock shaft pushes out farther than the distance noted, or you cannot push the shaft in until it hits the shock body, there is too much oil in the shock. pull the shaft all the way out and loosen the cap a half turn. slowly push the shaft in to pump out a small amount of oil. re-tighten the cap and repeat..

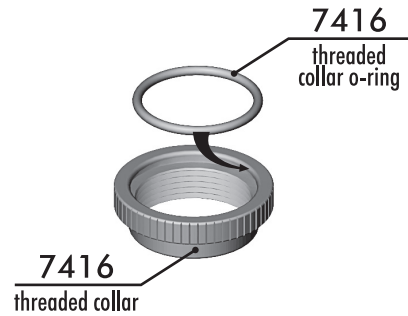
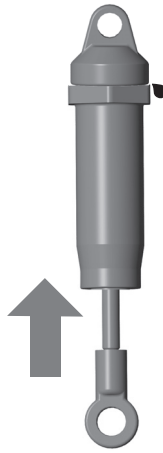

:: Shocks (cont.)

front: 14.98mm
rear: 4.27mm

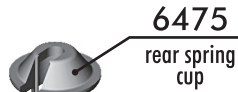
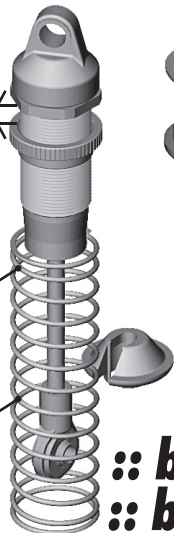

6475 rear spring cup

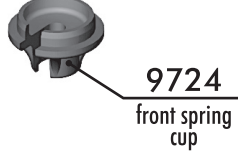

9724 front spring cup

6496 front spring silver 3.85lb

6480 rear spring green 1.90lb

:: build 2 front
:: build 2 rears

:: Turnbuckles

drag link (#1411) - x1

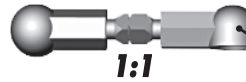

1:1

8828 short ball cup

front camber link (#1406) - x2



1:1

steering link (#1404) - x2



1:1

rear camber link (#1406) - x2



1:1

7230 ball cup

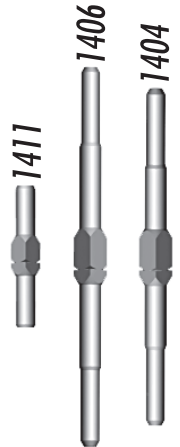

:: Front Gearbox

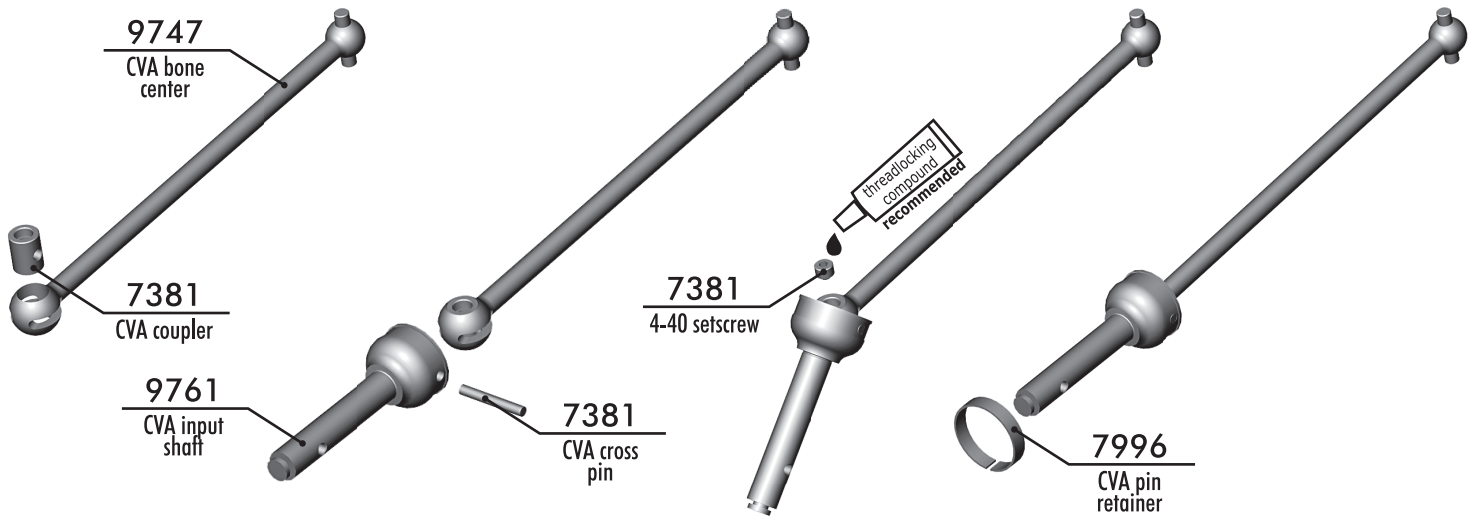

:: Front Gearbox (cont.)

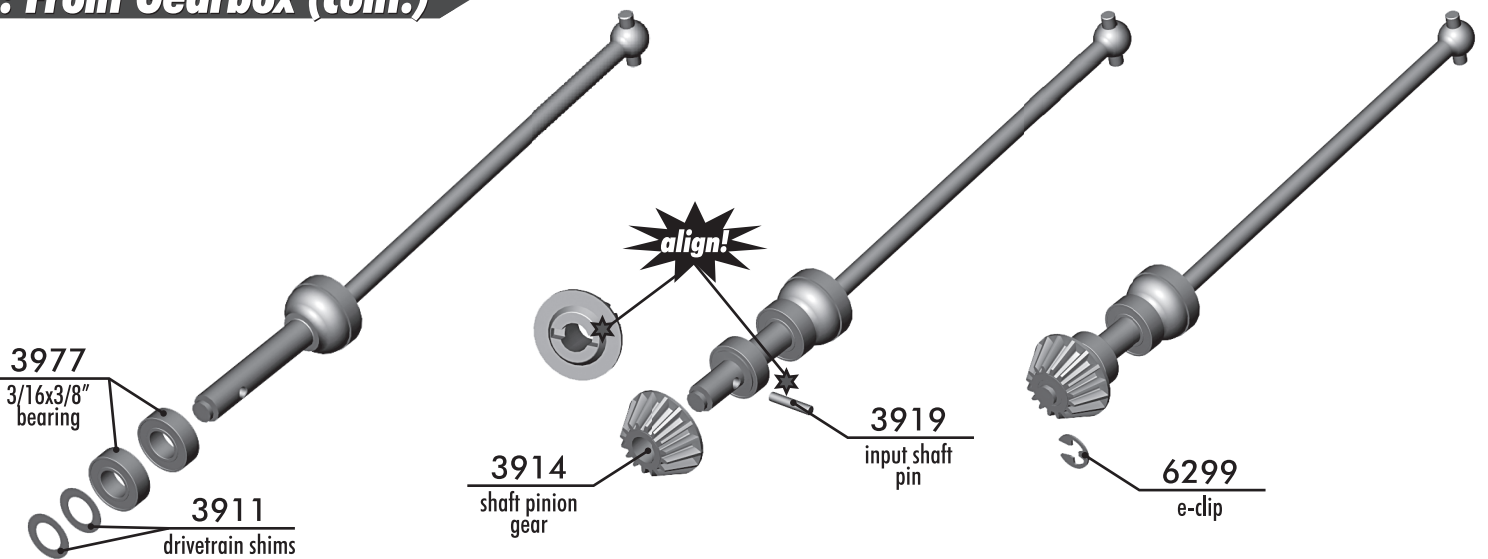

:: Front Gearbox (cont.)

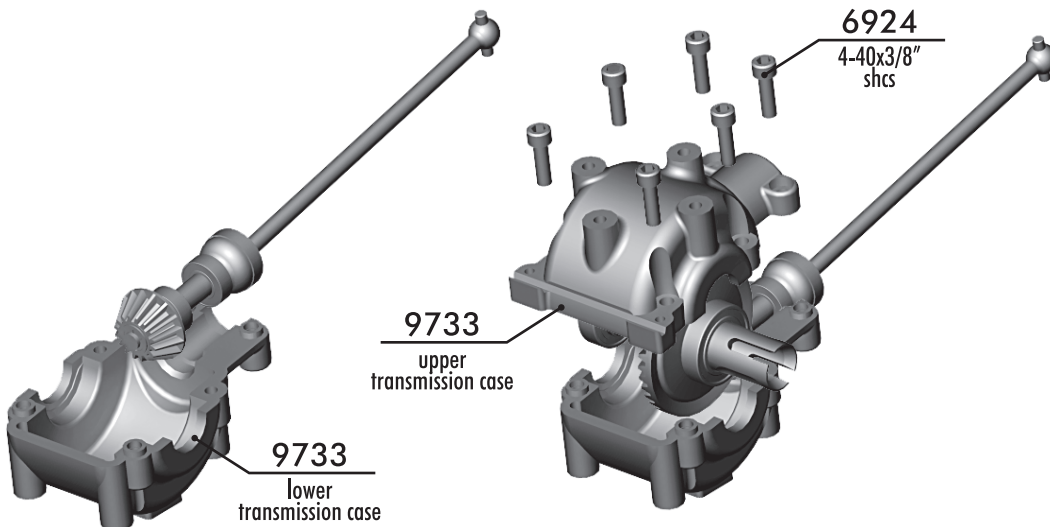

:: Steering

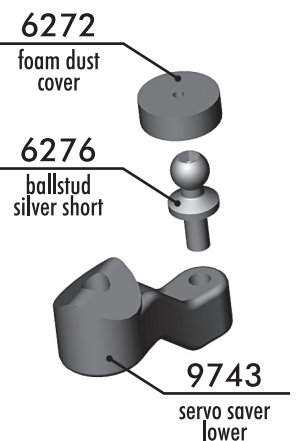

:: Steering (cont.)

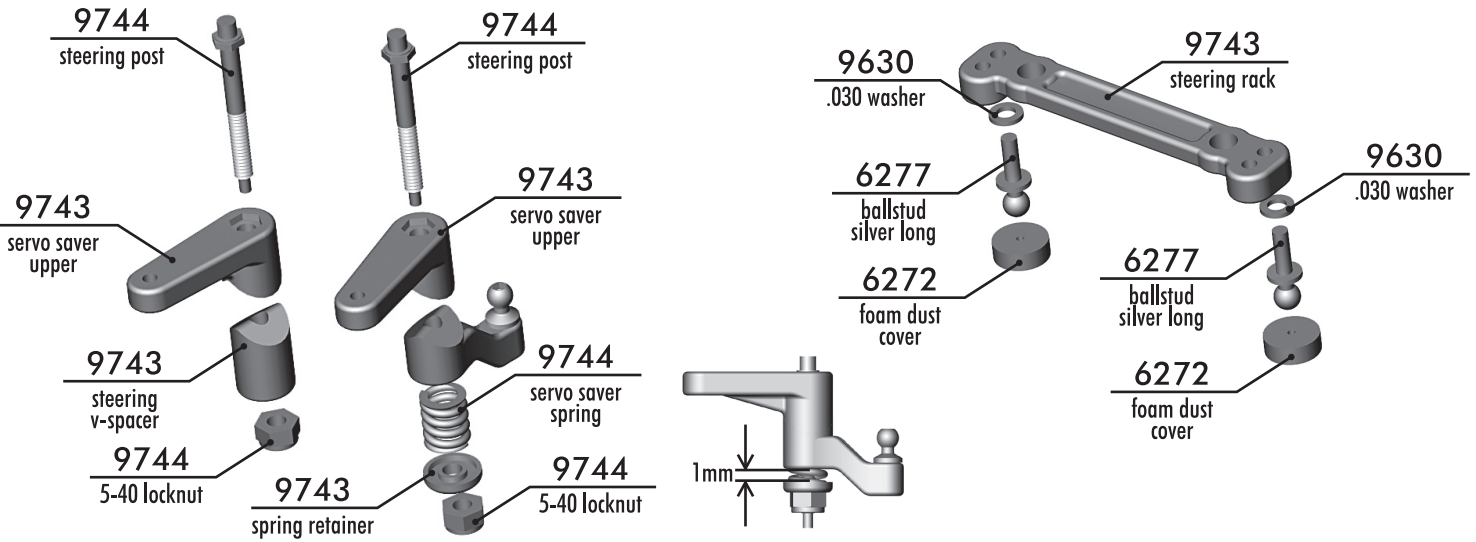

:: Steering (cont.)

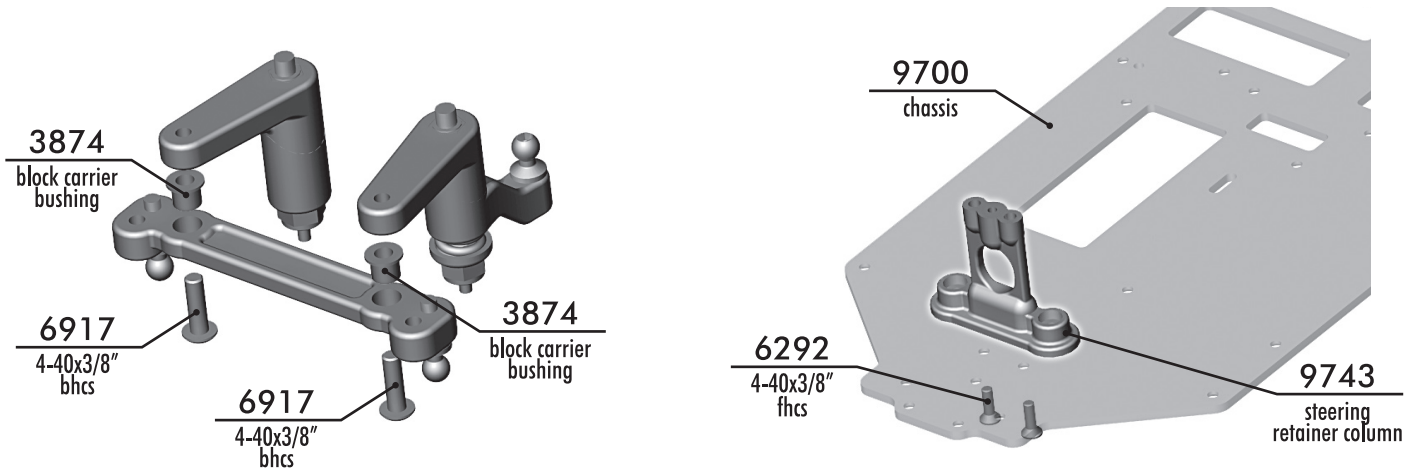

:: Steering (cont.)

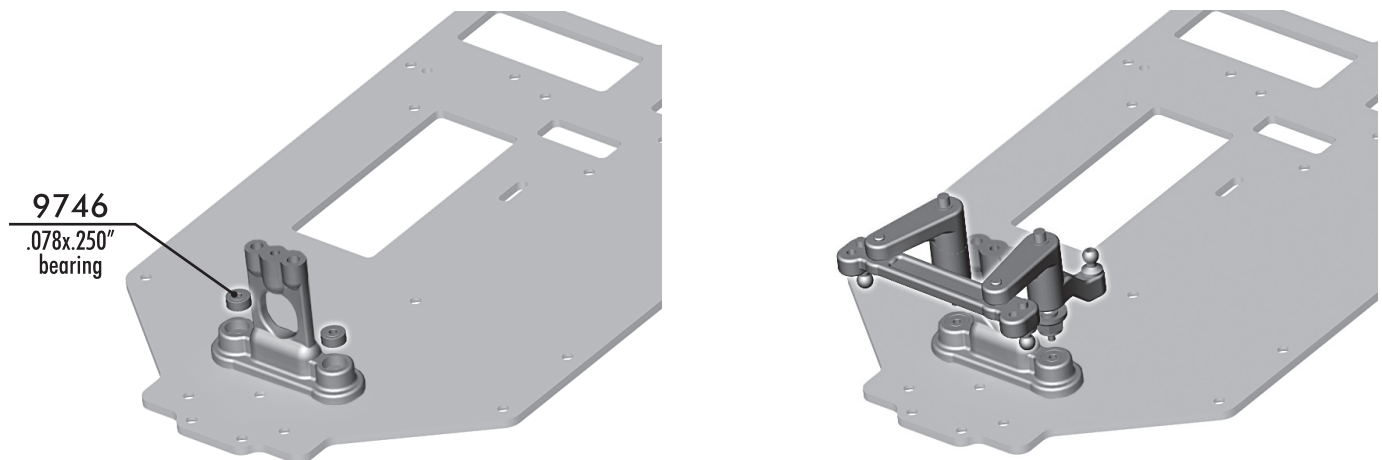

:: Steering (cont.)

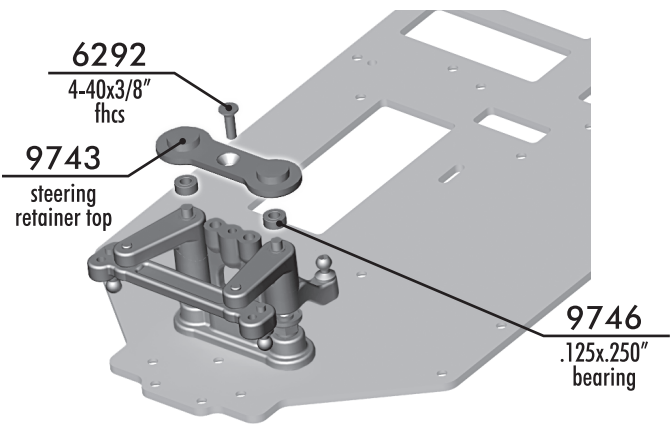

:: Front End

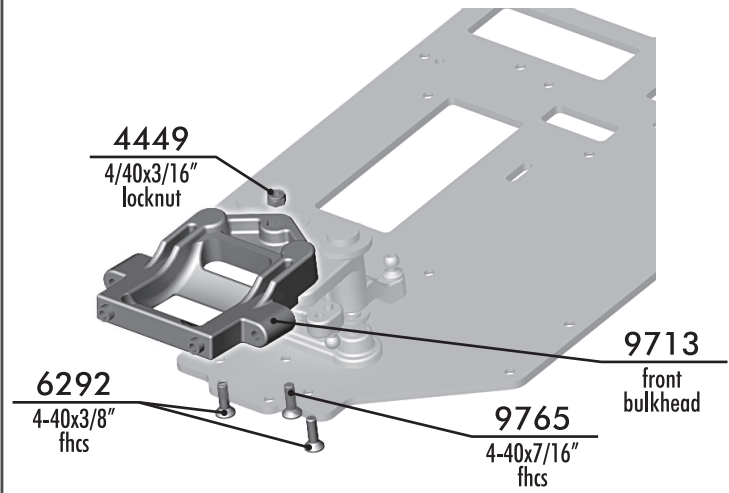

:: Front End (cont.)

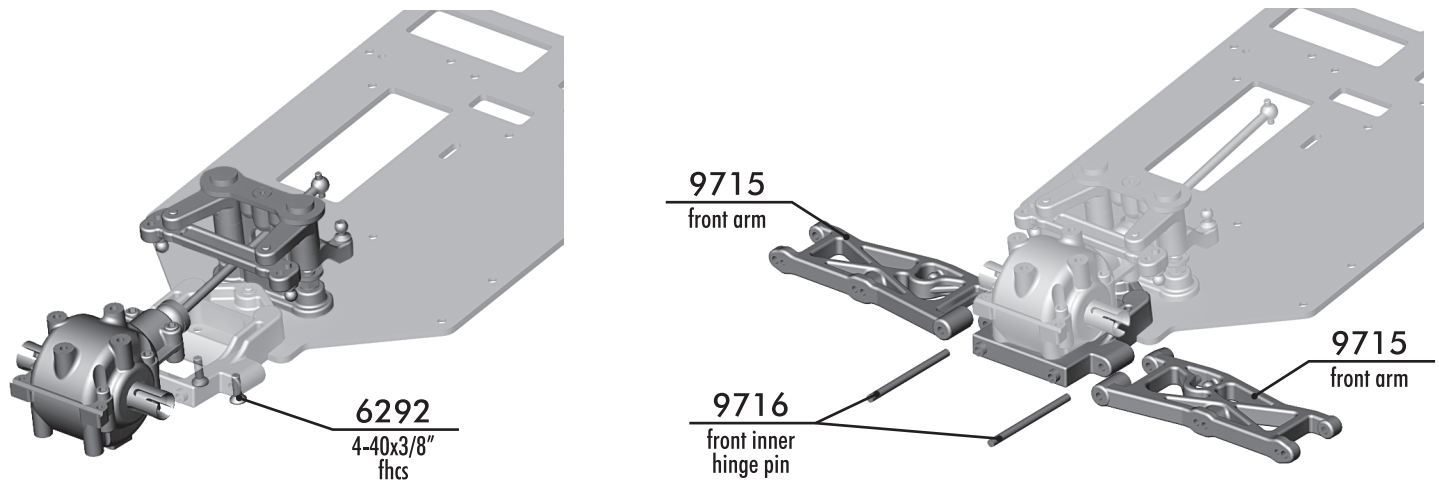

:: Front End (cont.)

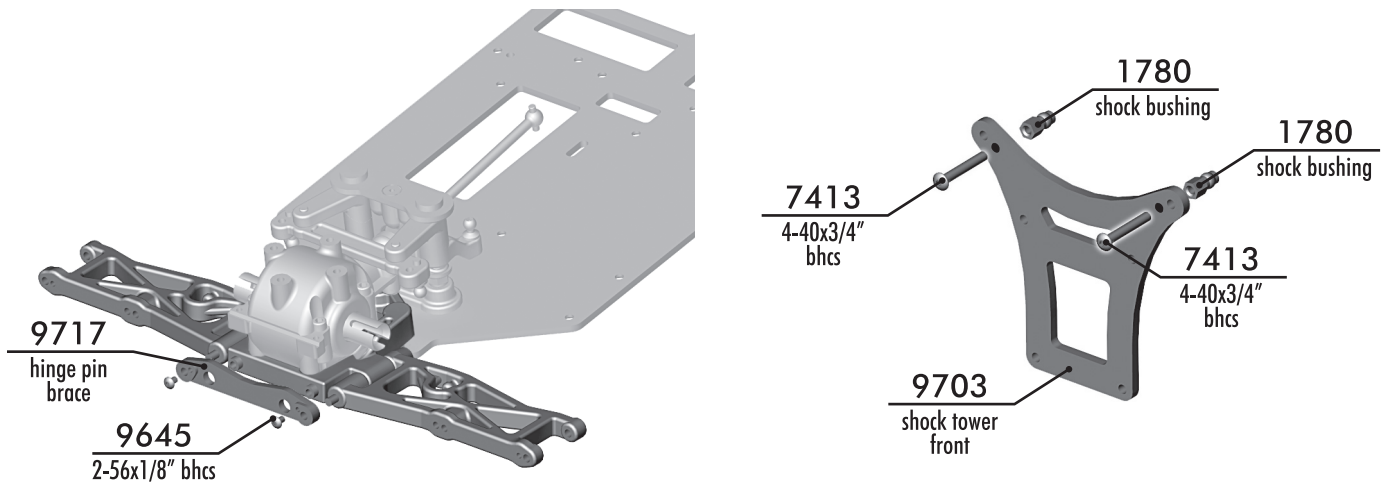

:: Front End (cont.)

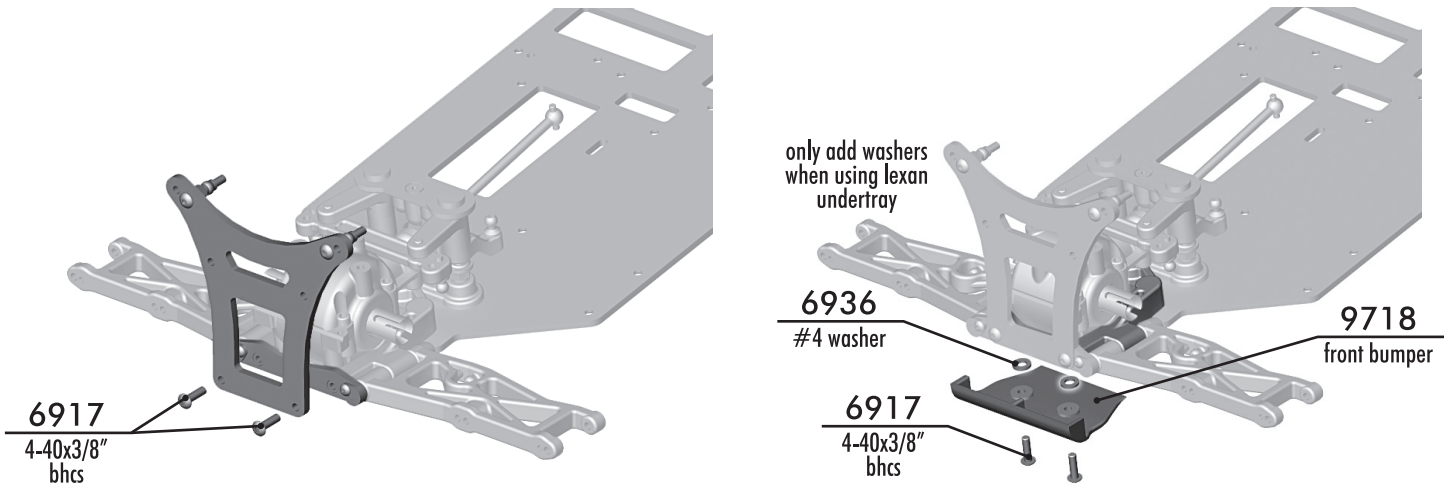

:: Front CVA

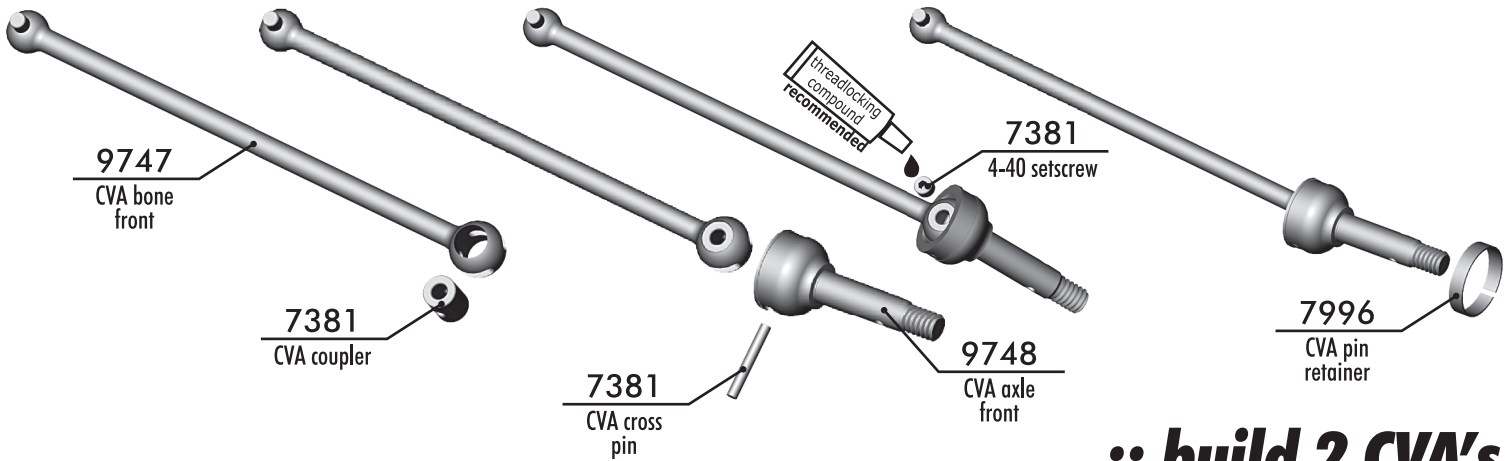

:: build 2 CVA's

:: Front Suspension

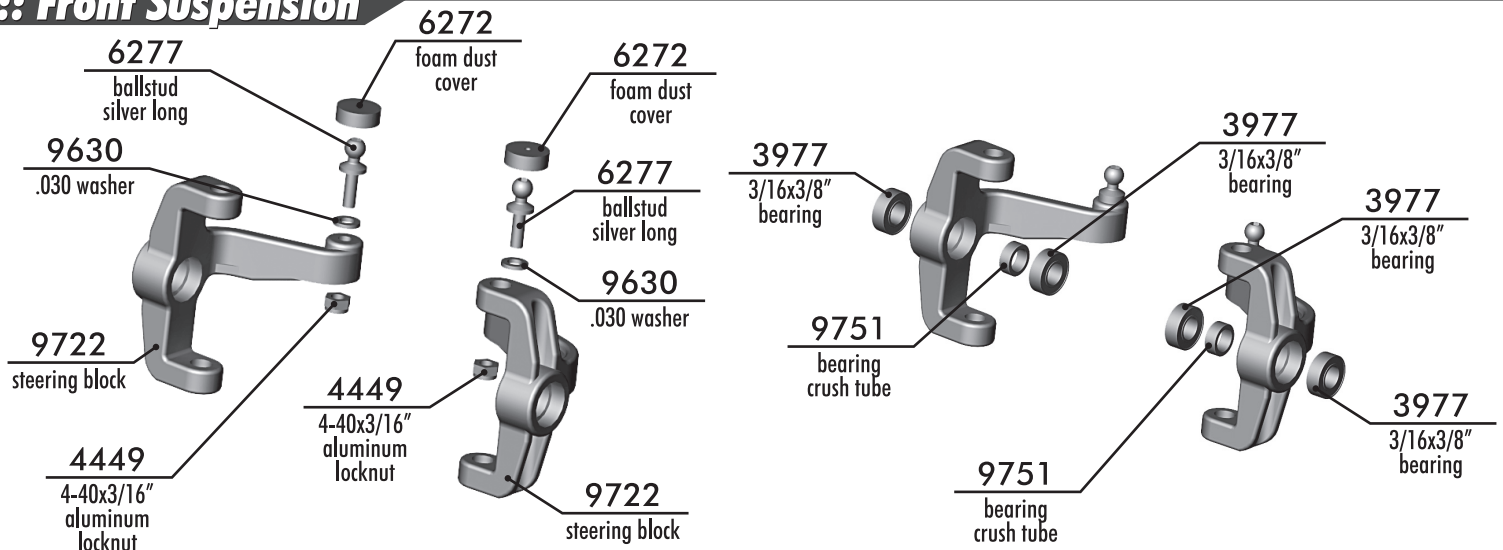

:: Front Suspension (cont.)

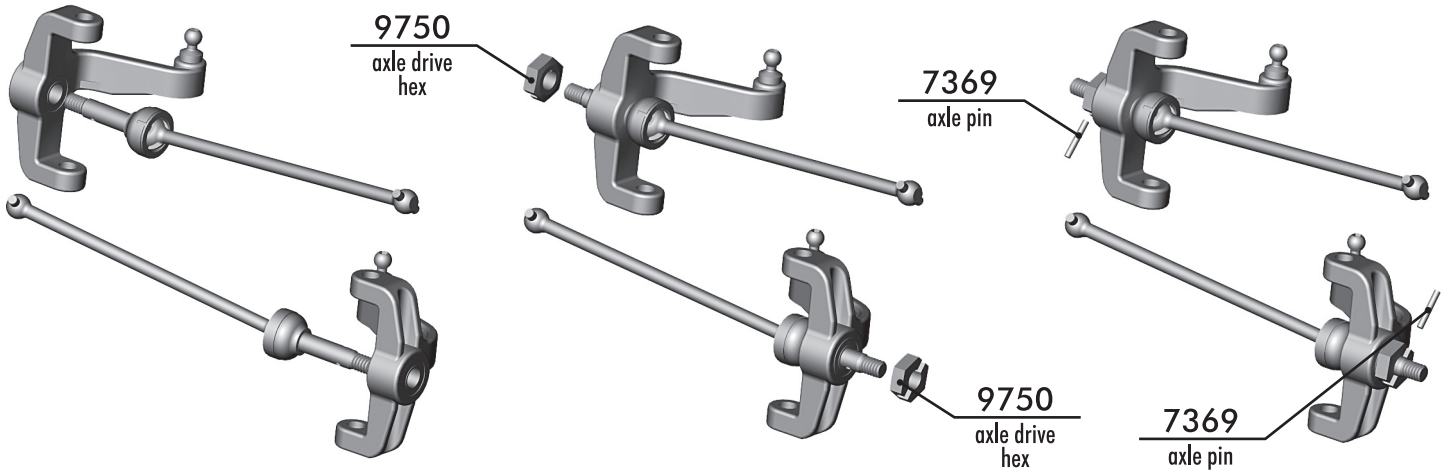

:: Front Suspension (cont.)

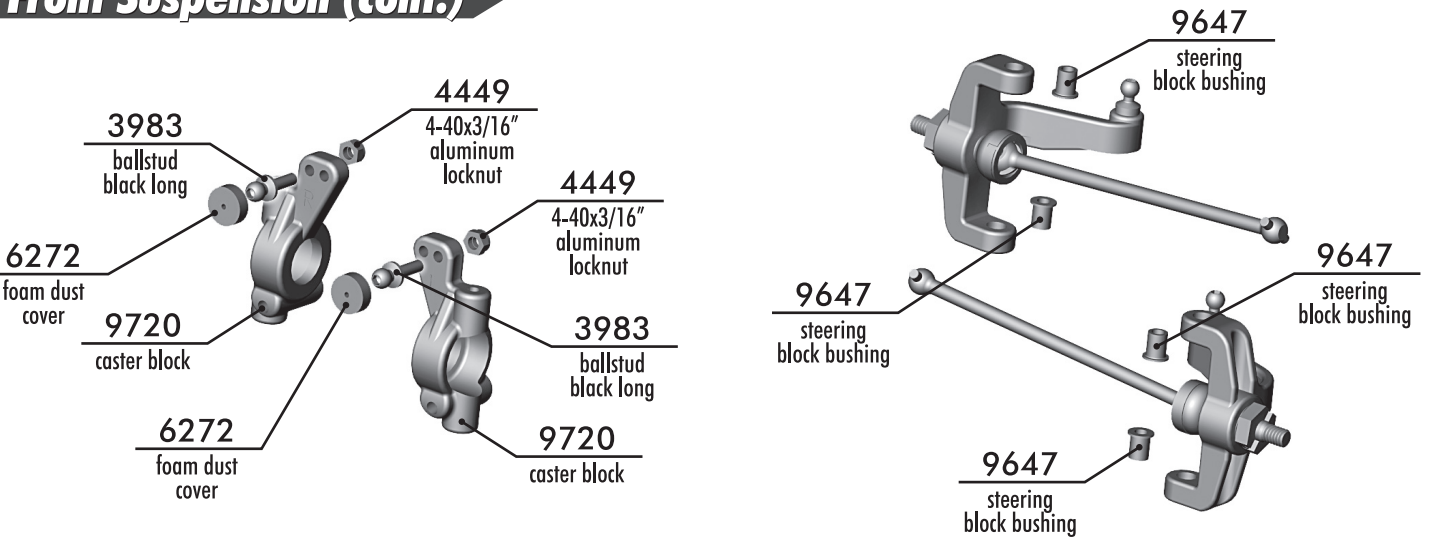

:: Front Suspension (cont.)

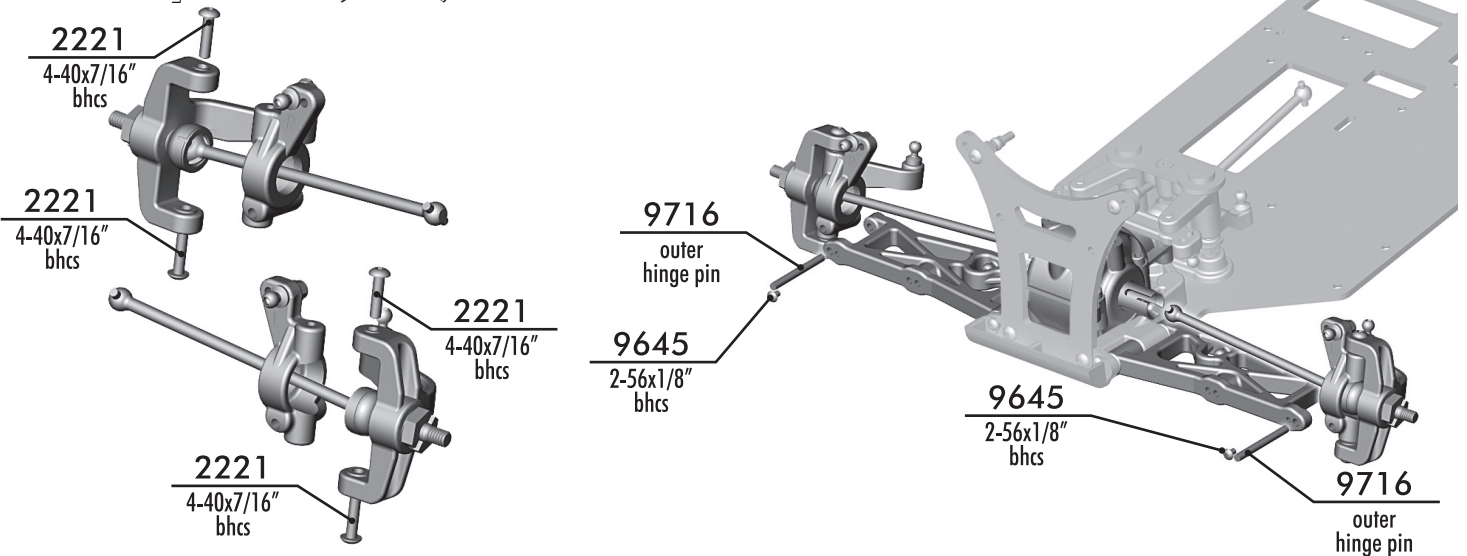

:: Front End (cont.)

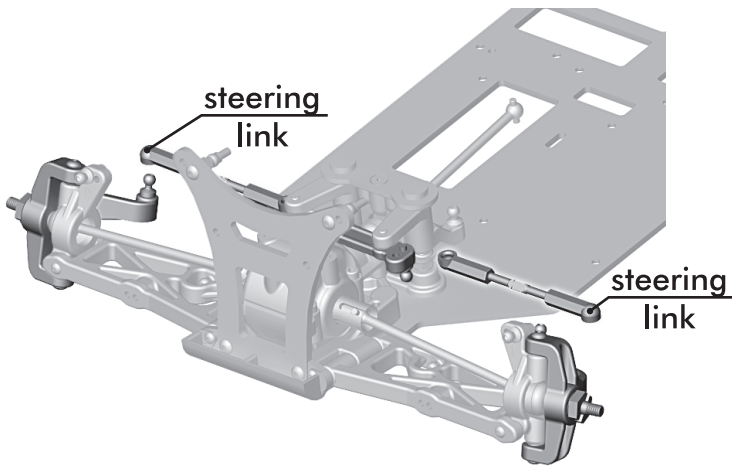

:: Top Deck - Front

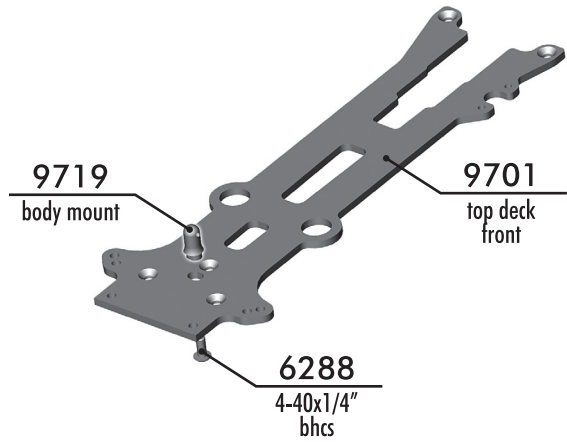

:: Top Deck (cont.)

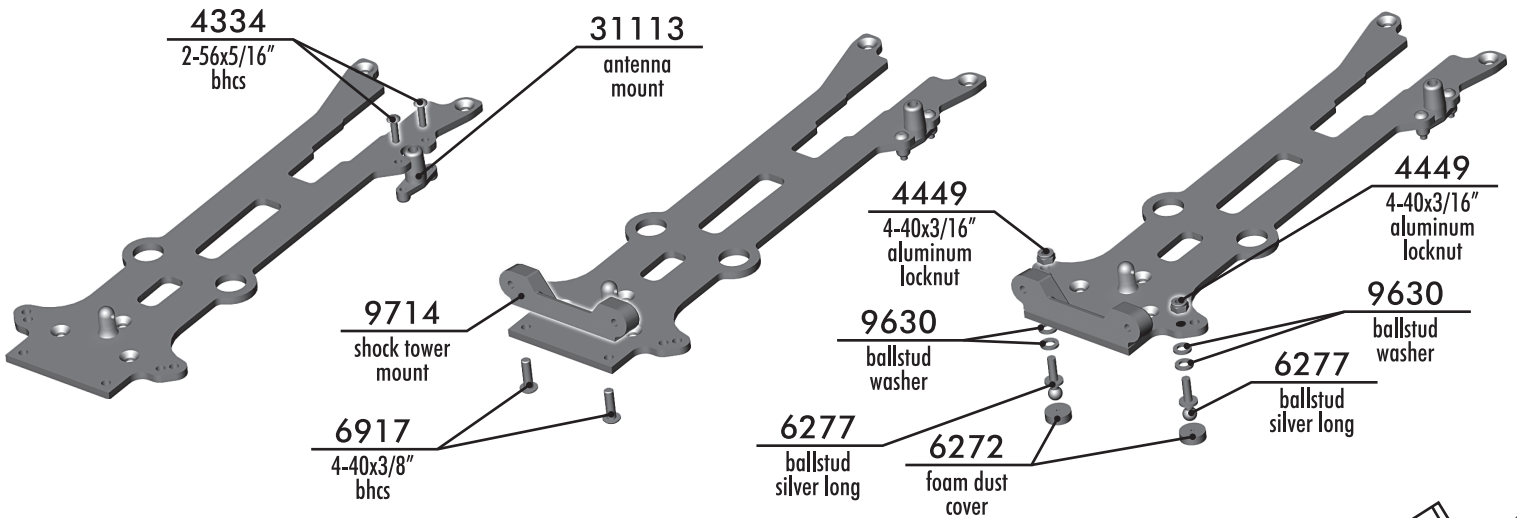

:: Top Deck (cont.)

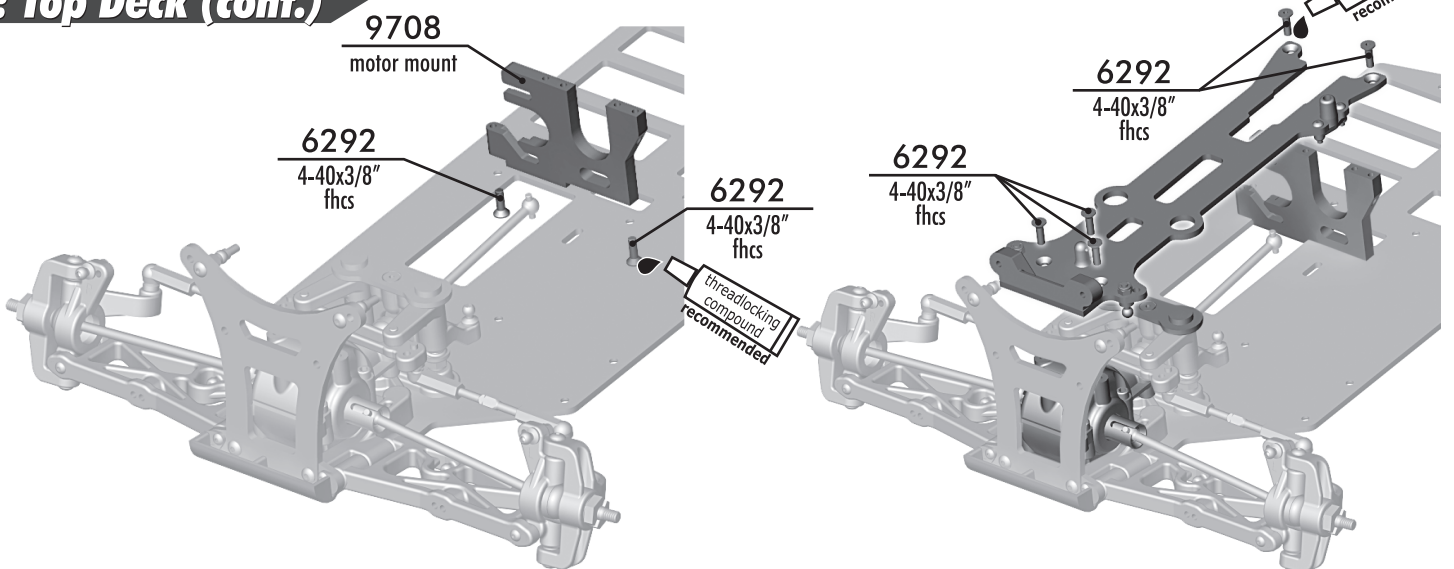

:: Top Deck (cont.)

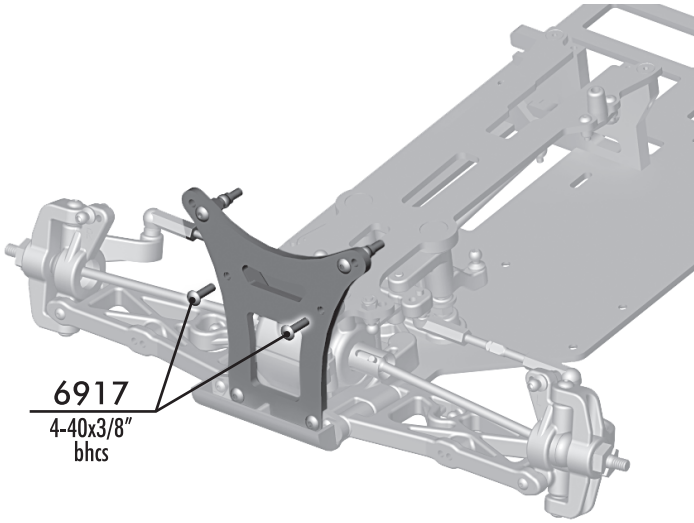

:: Front Turnbuckles

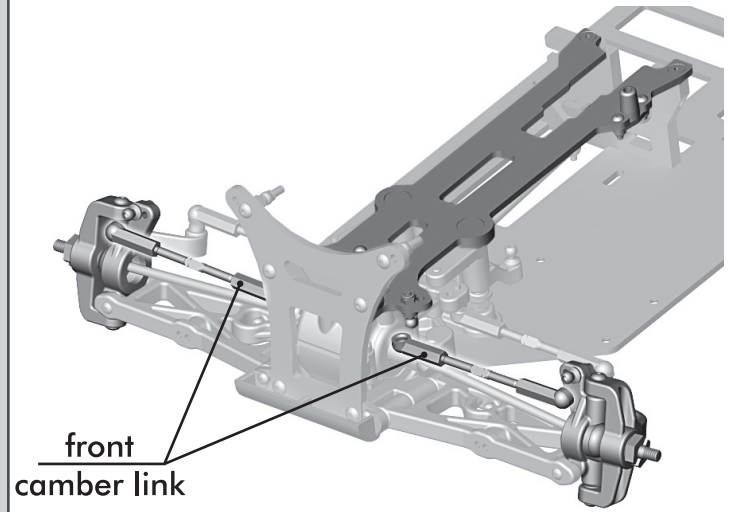

:: Front Shocks

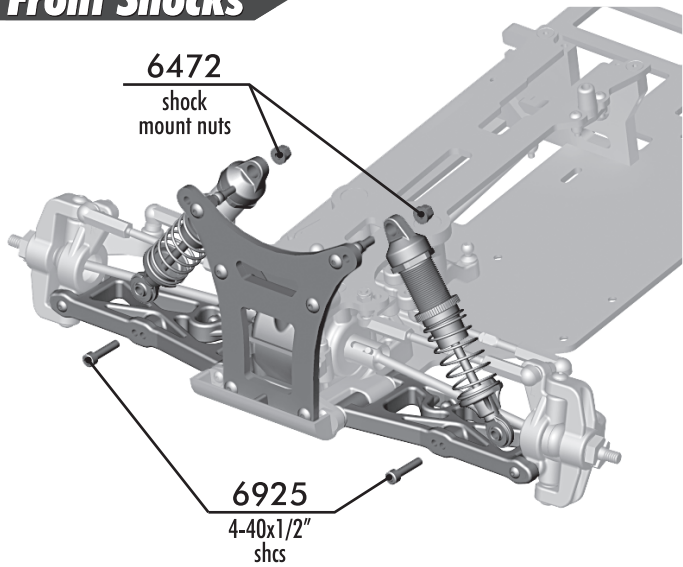

:: Center Bulkhead

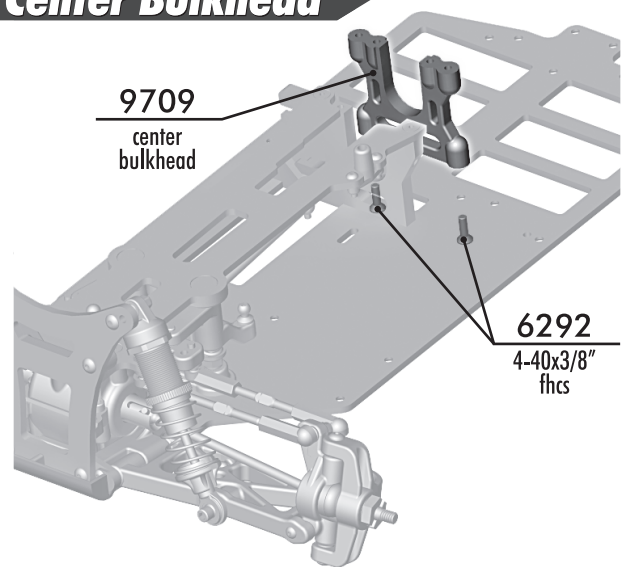

:: Rear Gearbox

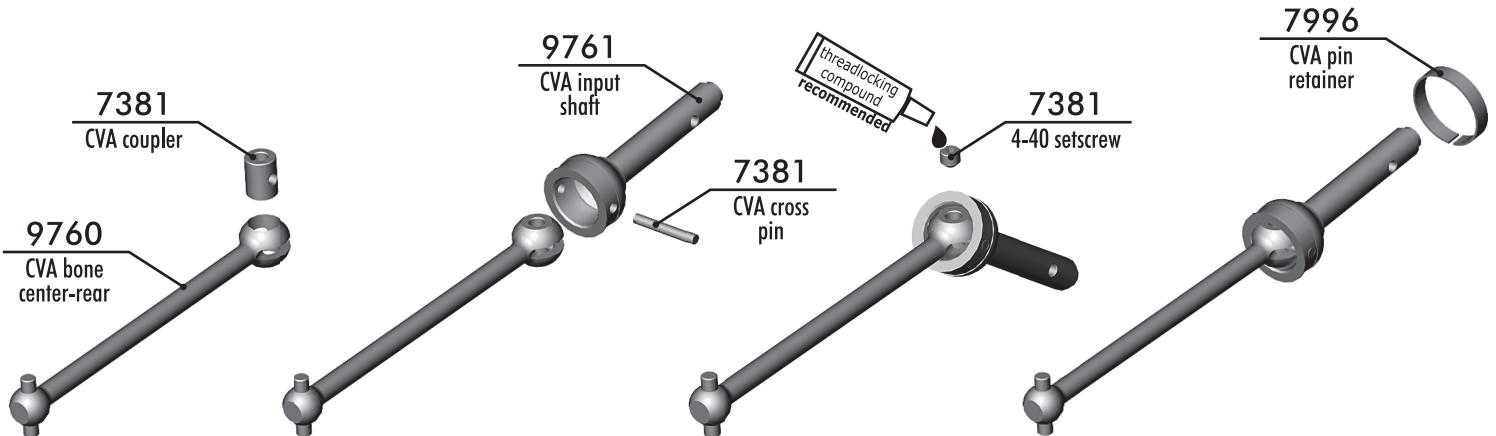

:: Exploded View

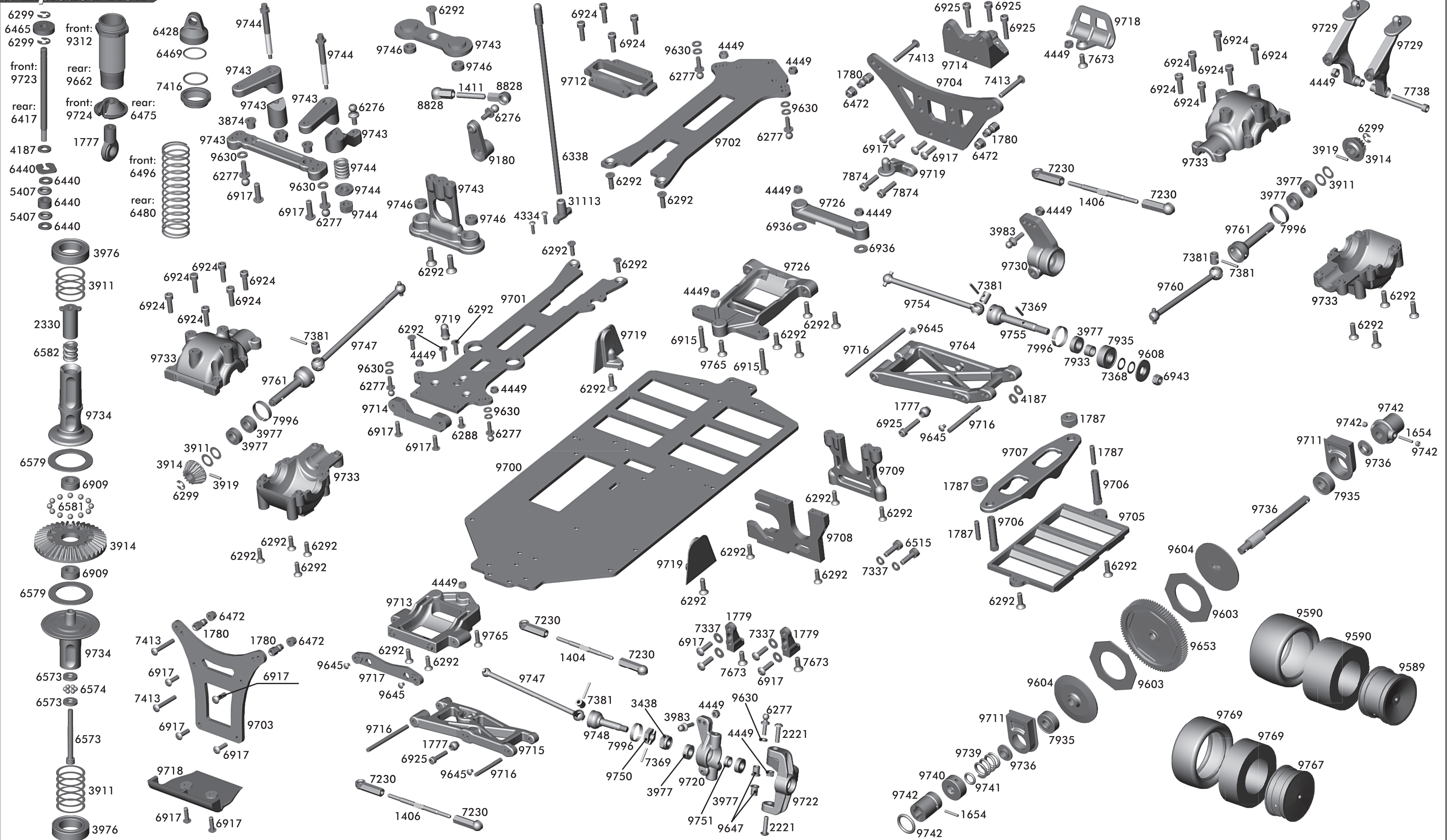

:: Rear Gearbox (cont.)

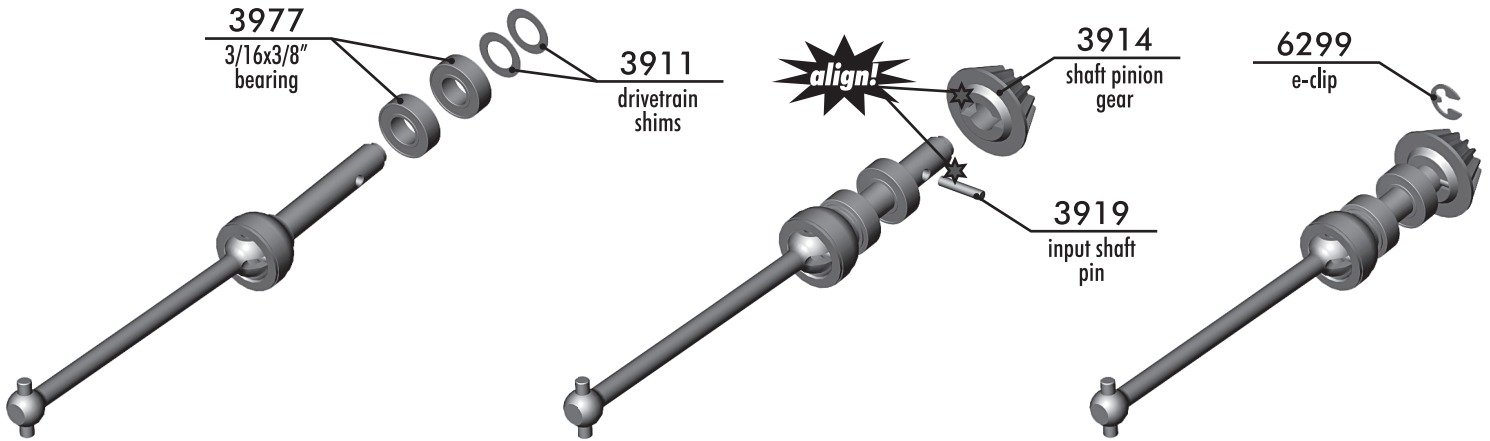

:: Rear Gearbox (cont.)

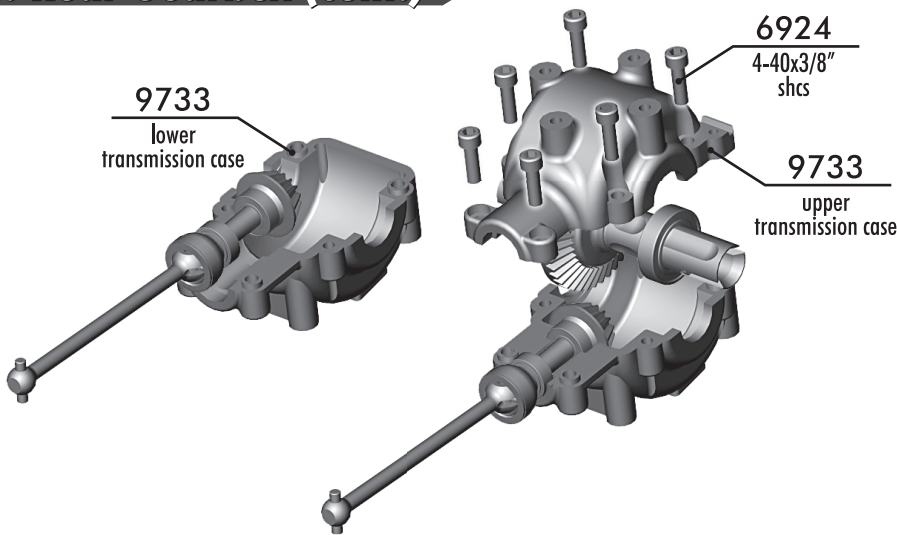

:: Rear End

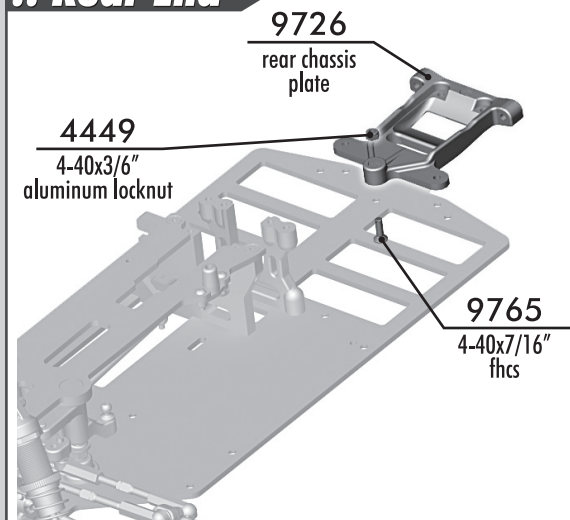

:: Rear End (cont.)

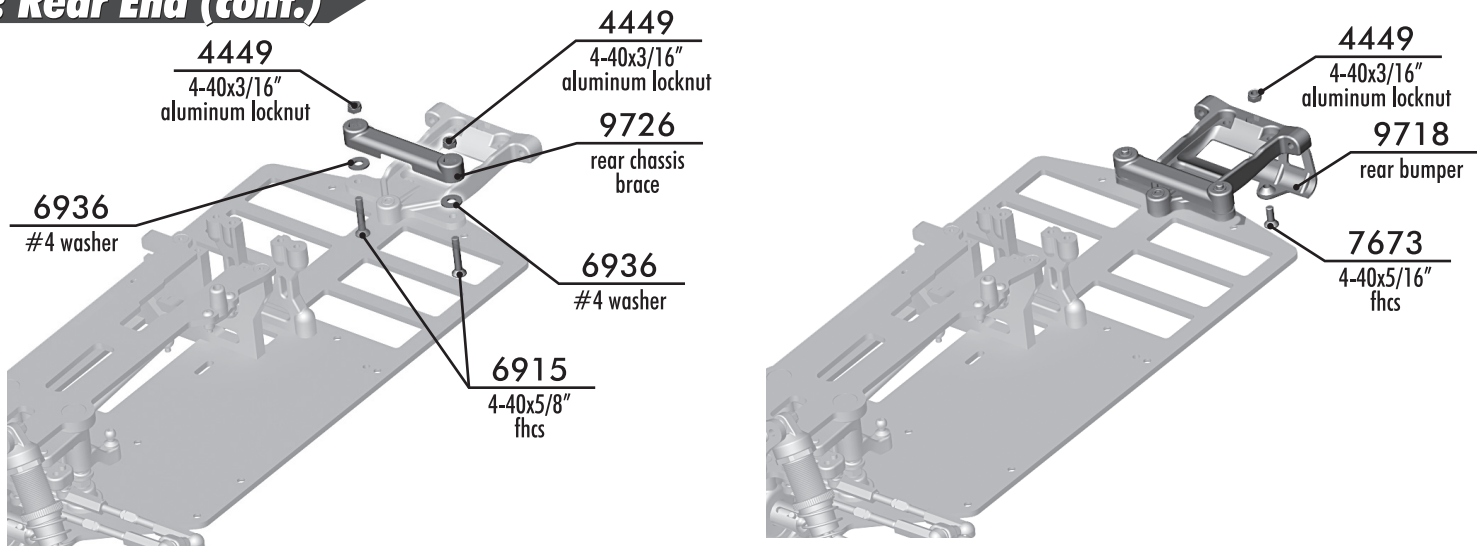

:: Rear End (cont.)

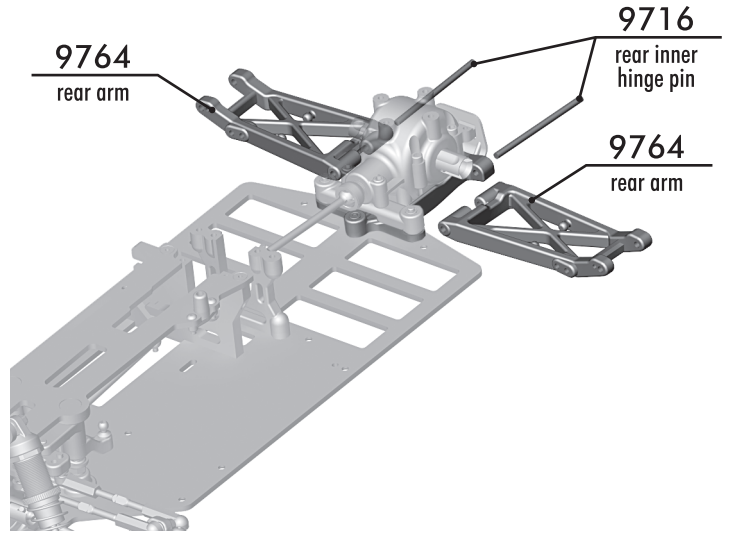
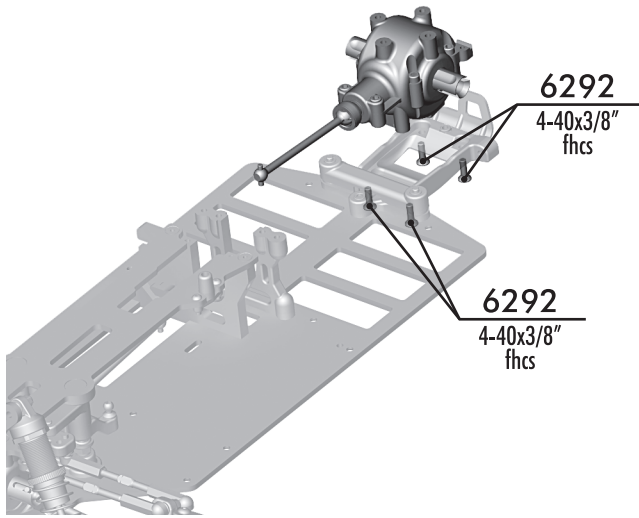

:: Rear End (cont.)

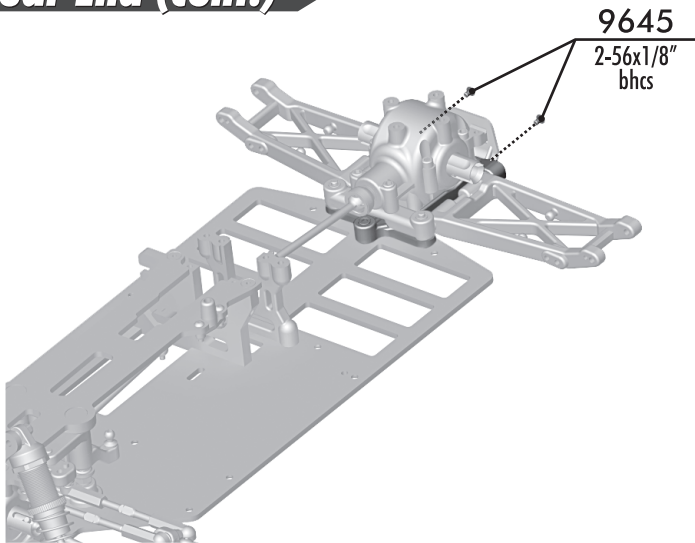

:: Rear CVA

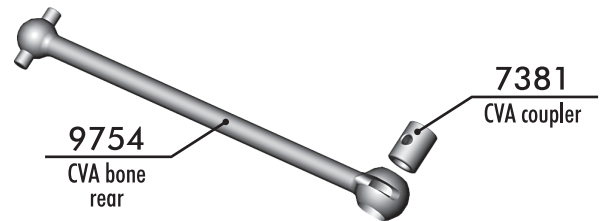

:: Rear CVA (cont.)

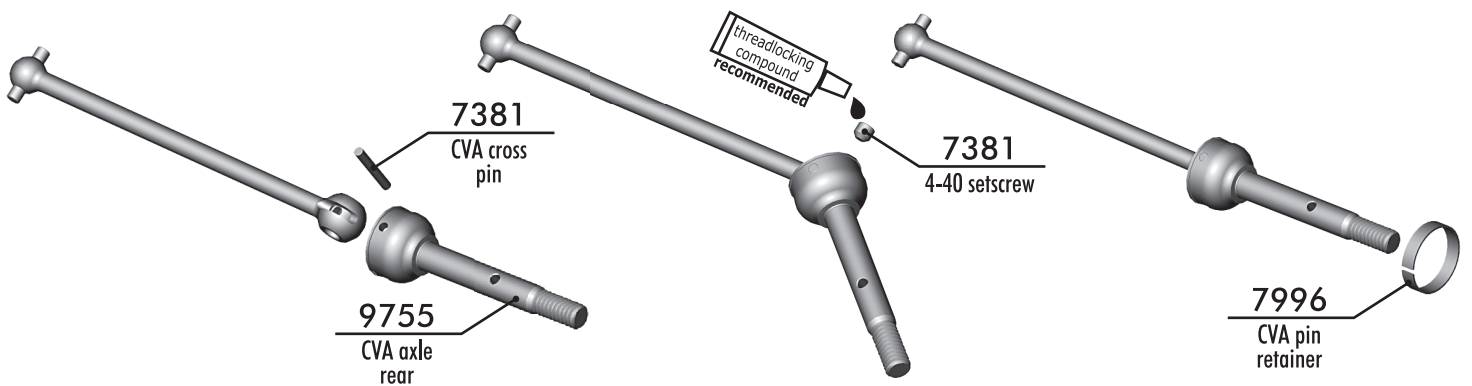

:: build 2 CVA's

:: Rear Suspension

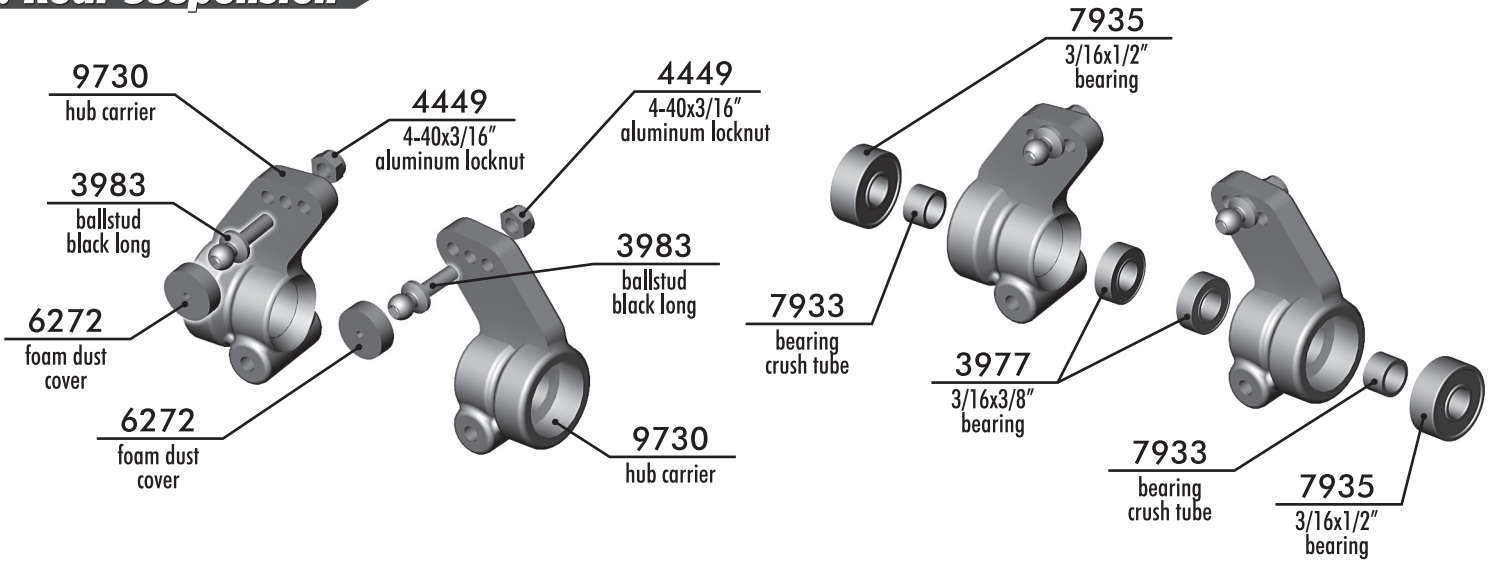

:: Rear Suspension (cont.)

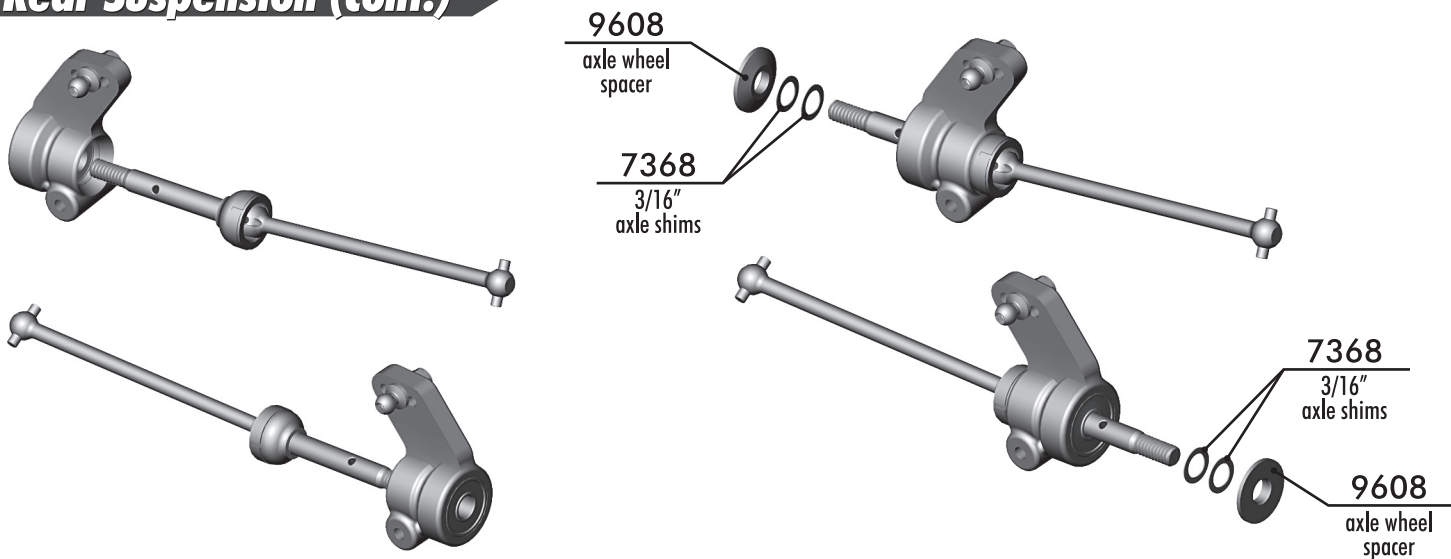

:: Rear Suspension (cont.)

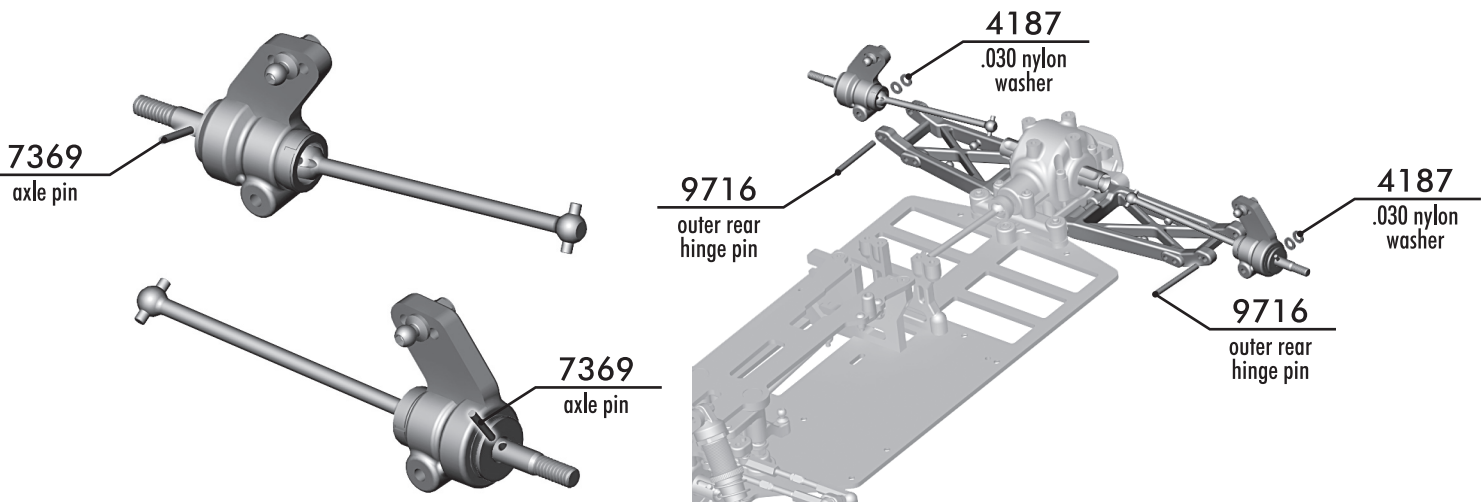

:: Rear End (cont.)

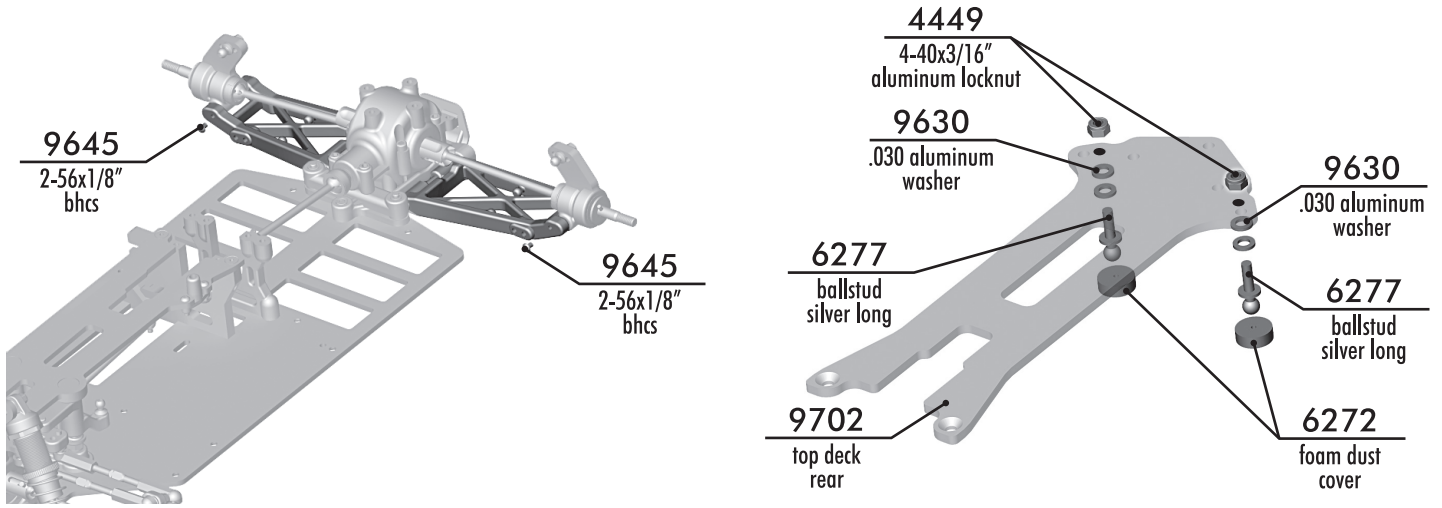

:: Rear End (cont.)

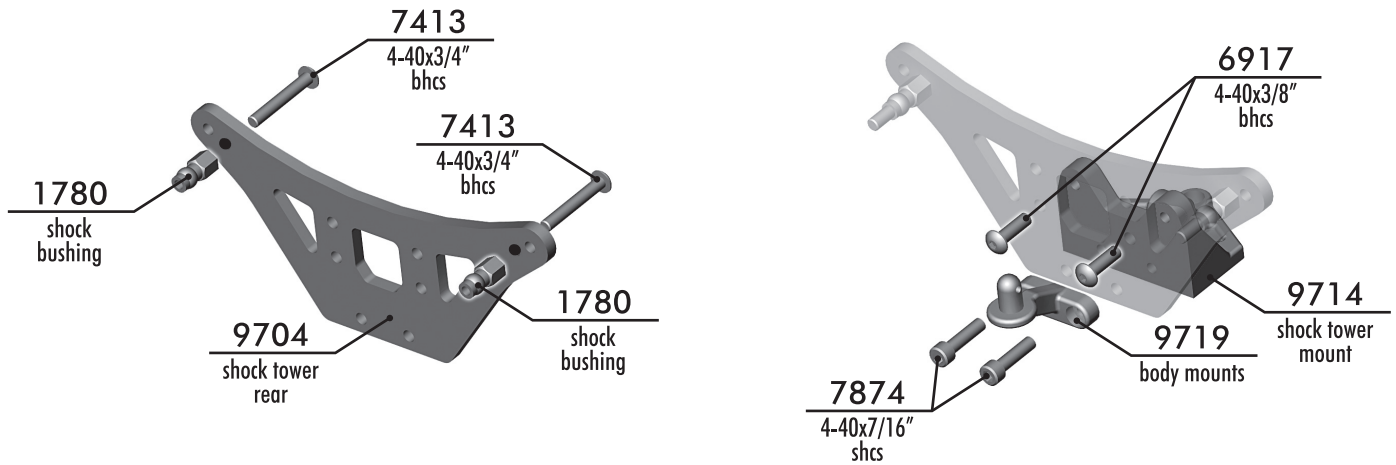

:: Rear End (cont.)

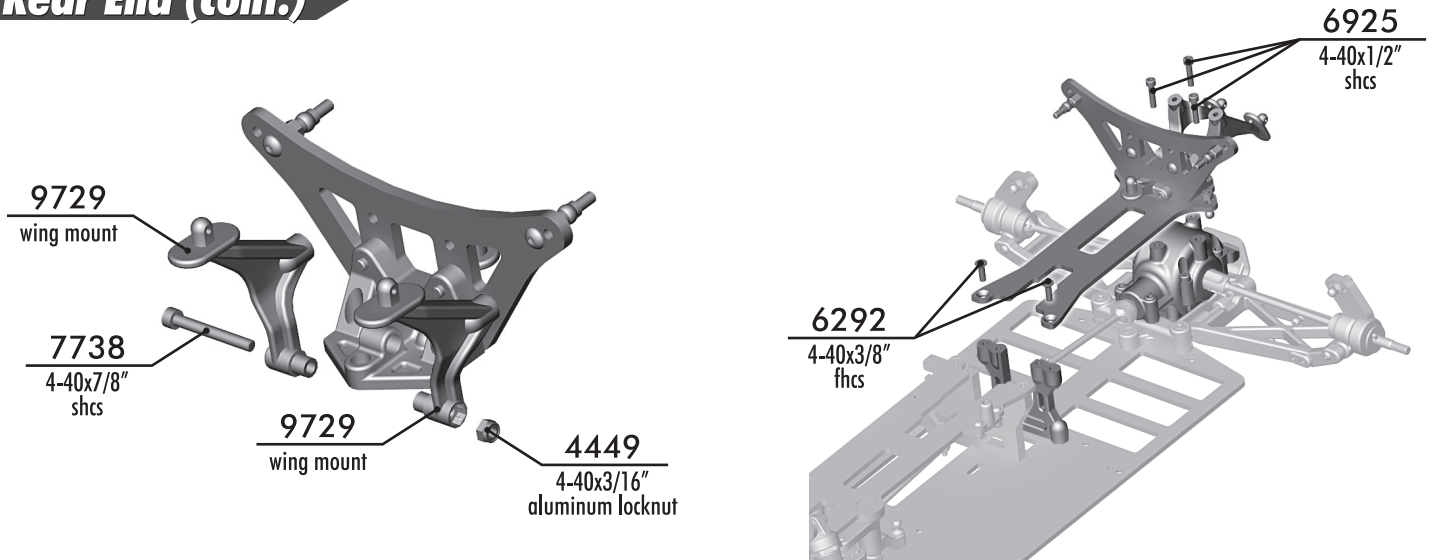

:: Rear Suspension (cont.)

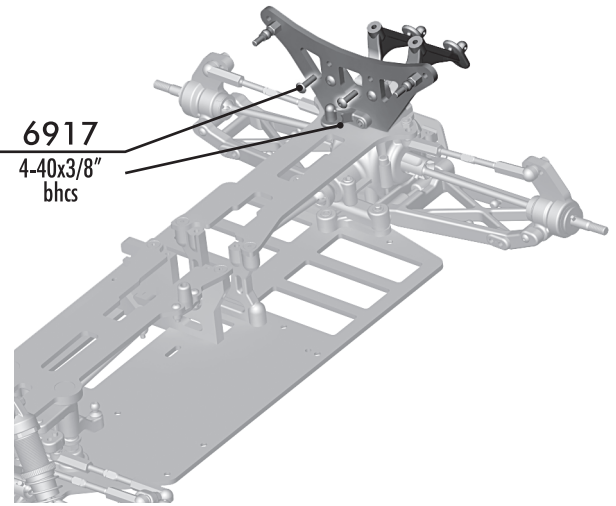
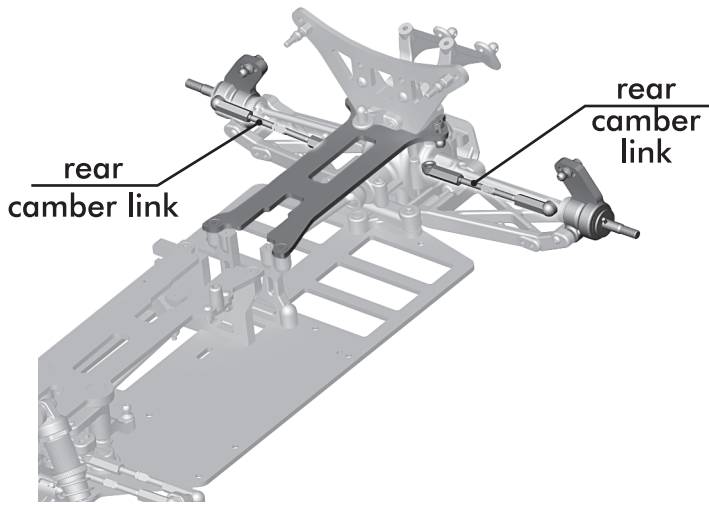

:: Rear Suspension (cont.)

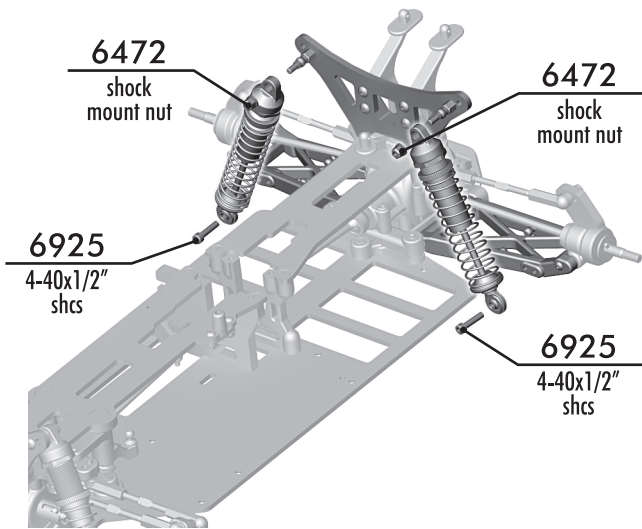

:: Battery Tray

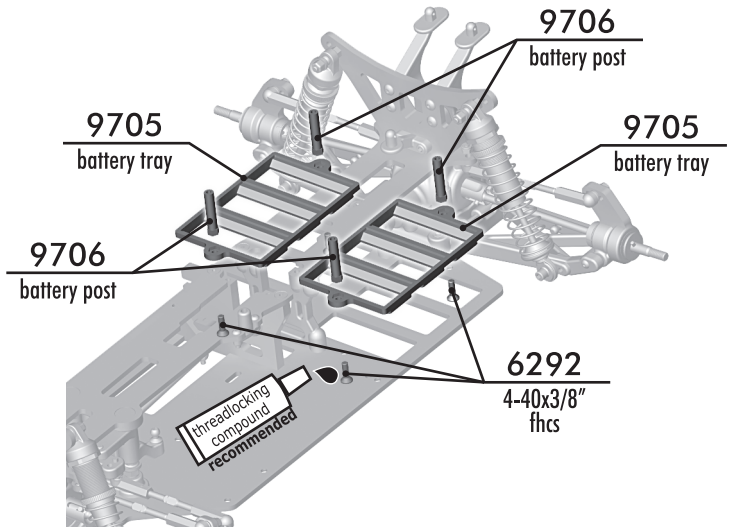

:: Battery Tray (cont.)

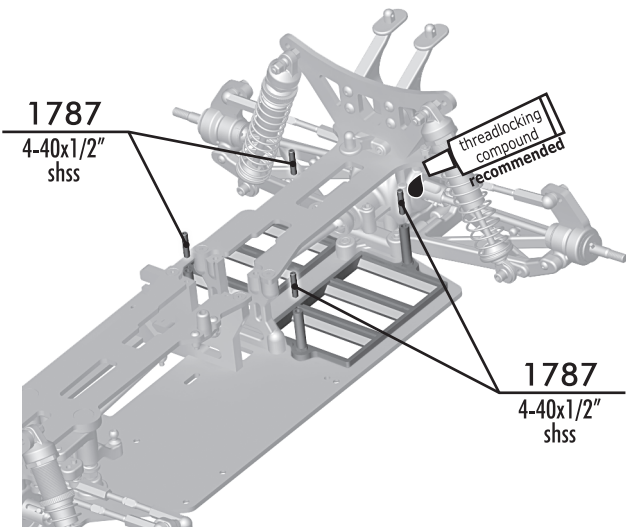

:: Slipper Clutch

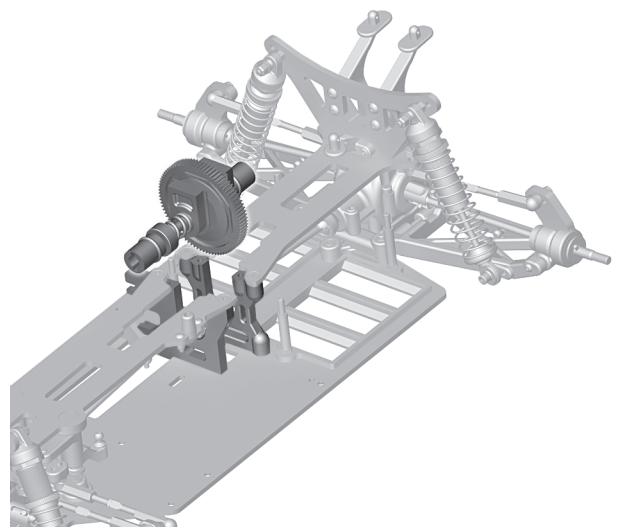

:: Slipper Clutch (cont.)

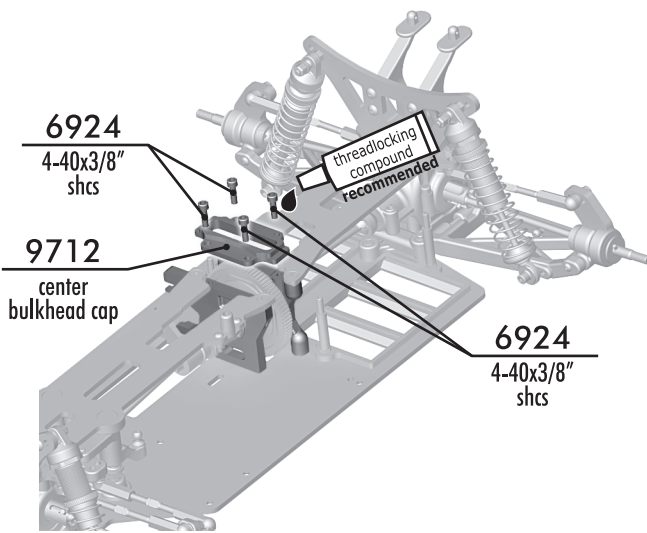

:: Electronics

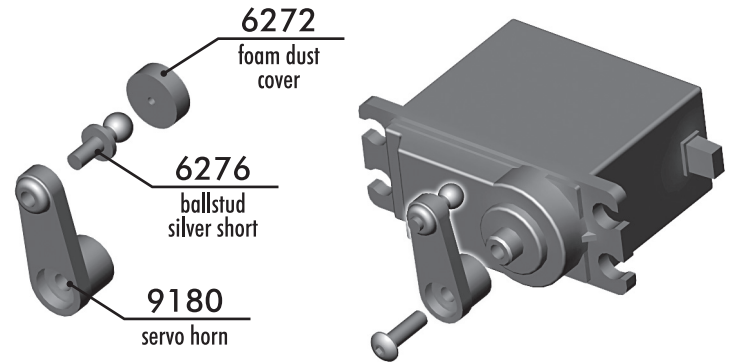

:: Electronics (cont.)

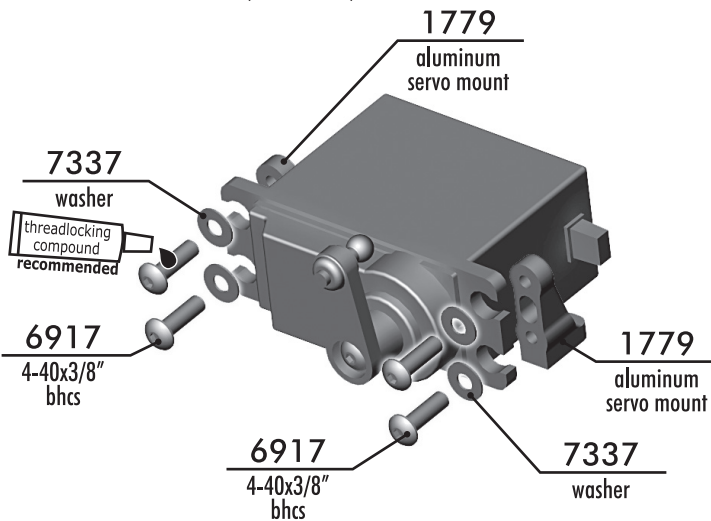

:: Servo List

*Not all servo's are listed.

| | #7336 Spacer | #9180 Servo Arm |
|--|-----------------|--------------------|
| Airtronics 94102 | no spacer | A |
| Airtronics 94738, 94157, 94158, 94257, 94258, 94357, 94358, 94452, 94453, 94751, 94755 | thick spacer | A |
| Hitec HS-5625MG, HS-5645MG, HS625MG, HS645MG | no spacer | H |
| Hitec HS-303, HS-300BB, HS-945MG, HS-925MG, HS-5945MG, HS-5925MG, HS-525MG, HS-525BB, HS-425BB, HS-422 | thin spacer | H |
| JR Z4725, Z4750, Z2750, Z8450, Z8550, NES-4750 | no spacer | J |
| JR Z250, Z550 | thin spacer | J |
| Futaba S9204, S9250, S9450, S148 | no spacer | F |
| Futaba S3003, S9202, S9101 | thin spacer | F |
| Futaba S9404 | thick spacer | F |
| KO PS-401, PS-2001, PS-2004, PS-2015, PS-2173, PS-2174, PS-2123, PS-2143, PS-2144 | thin spacer | J |

:: Electronics (cont.)

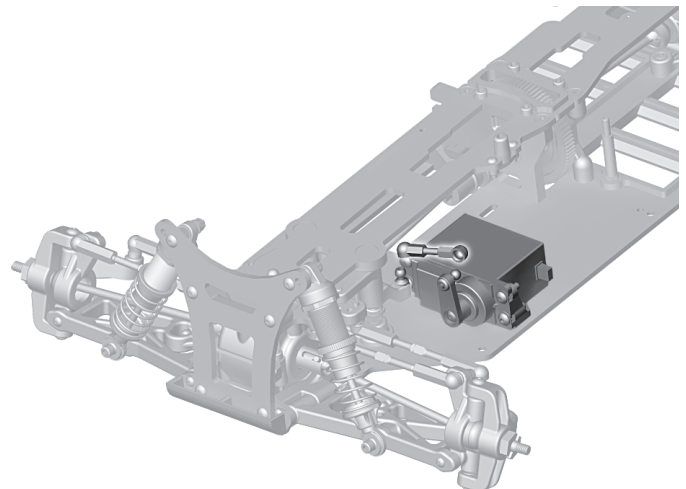
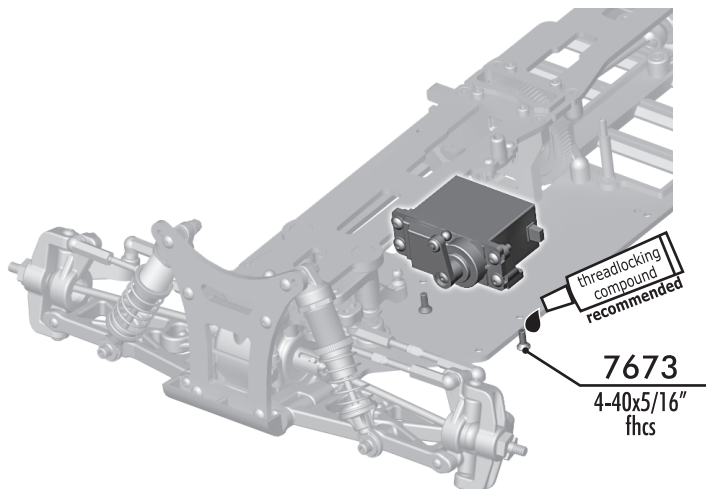

:: Electronics (cont.)

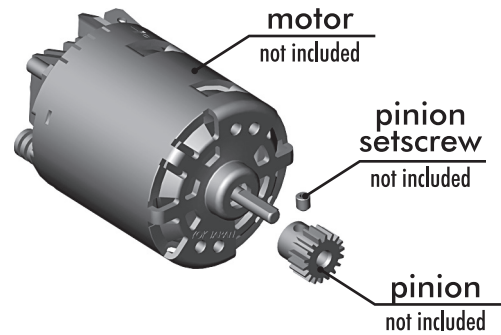
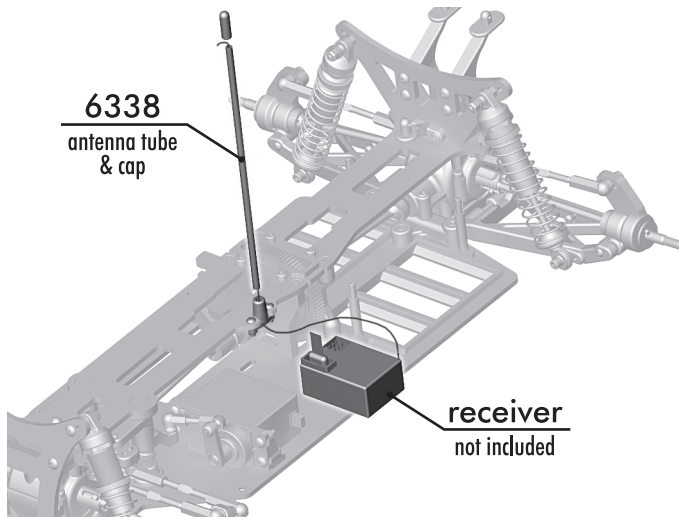

:: Electronics (cont.)

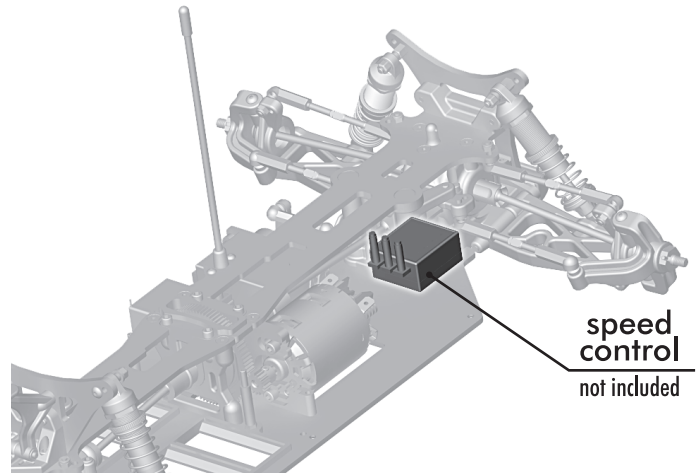
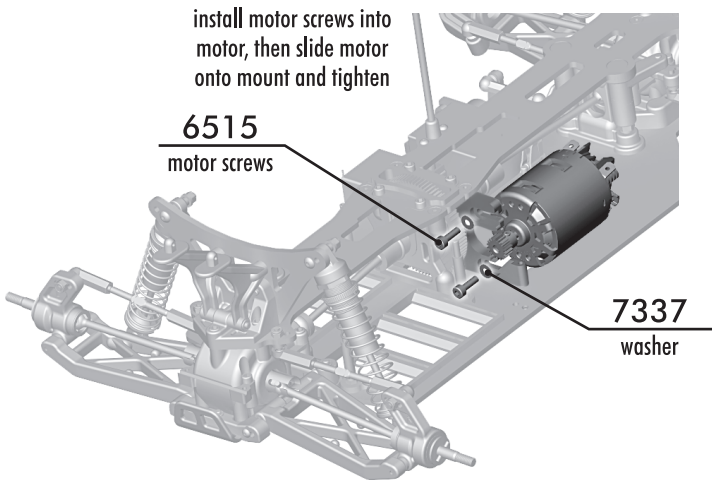

:: Electronics (cont.)

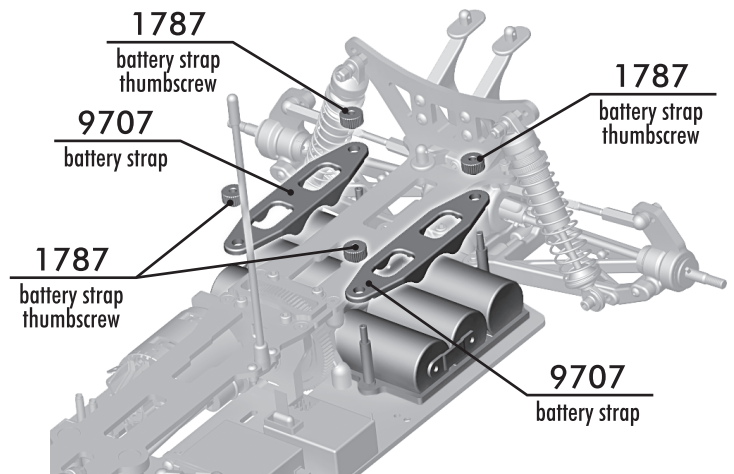
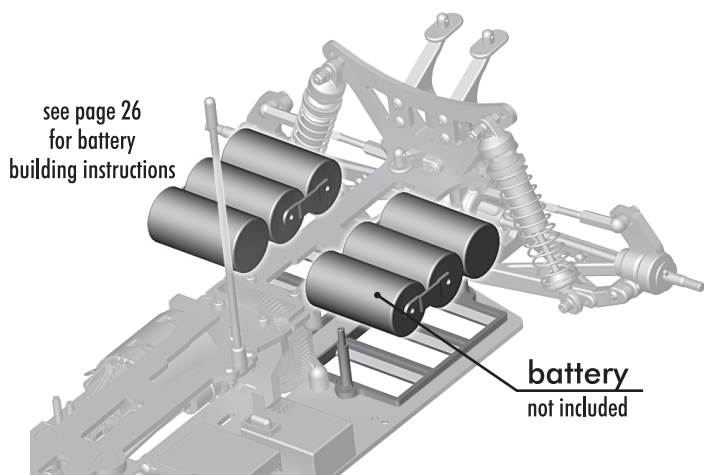

:: Final Assembly

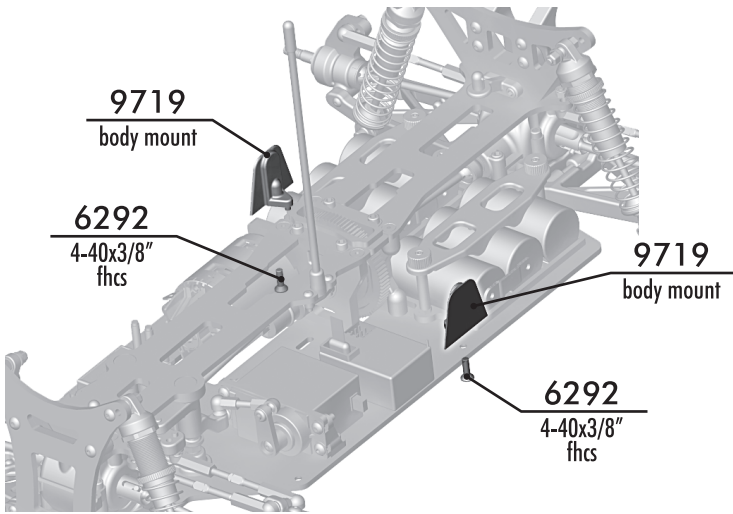

:: Front Tires

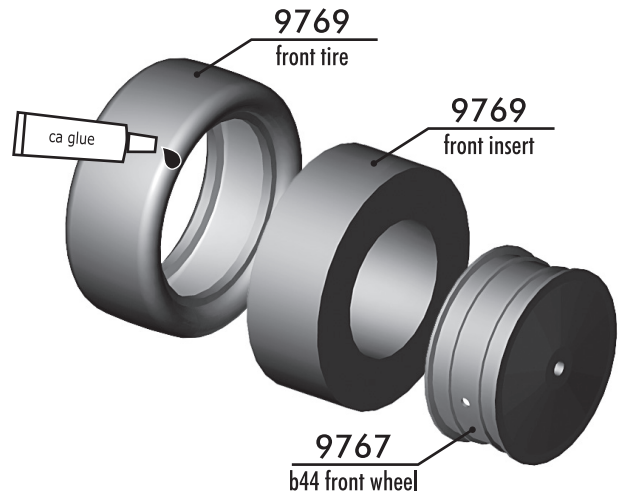

:: Front Tires (cont.)

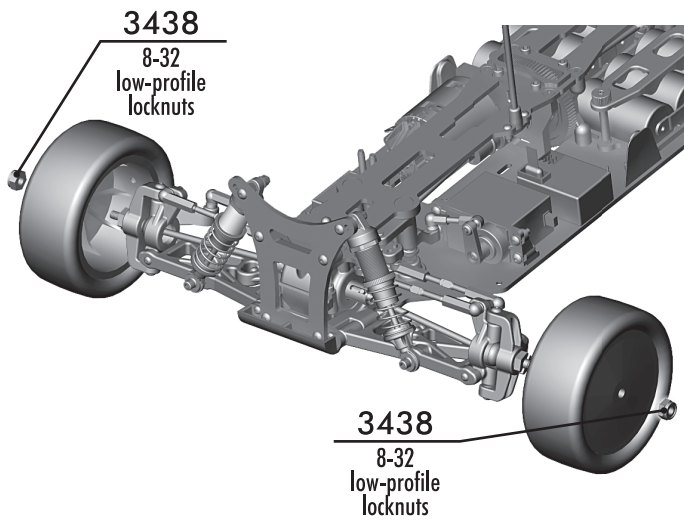

:: Rear Tires

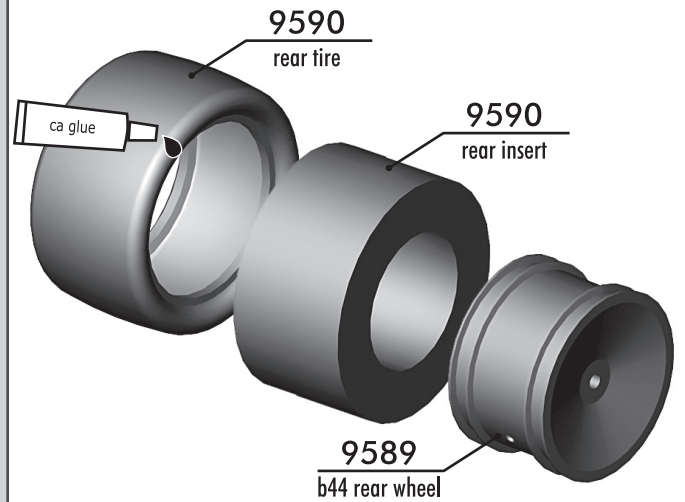

:: Rear Tires (cont.)

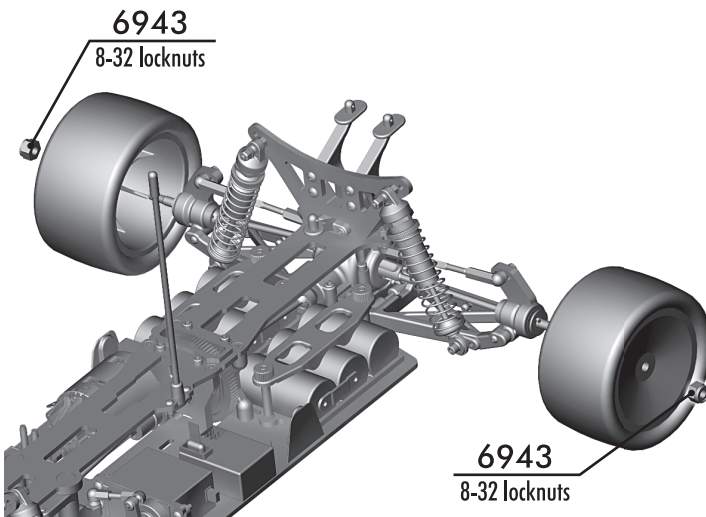

:: Body

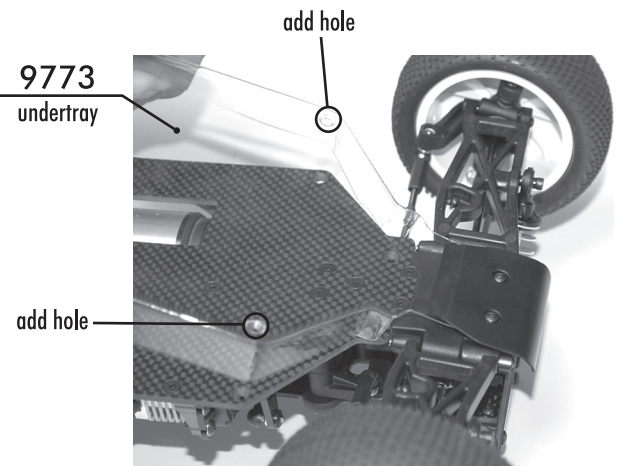

:: Body (cont.)

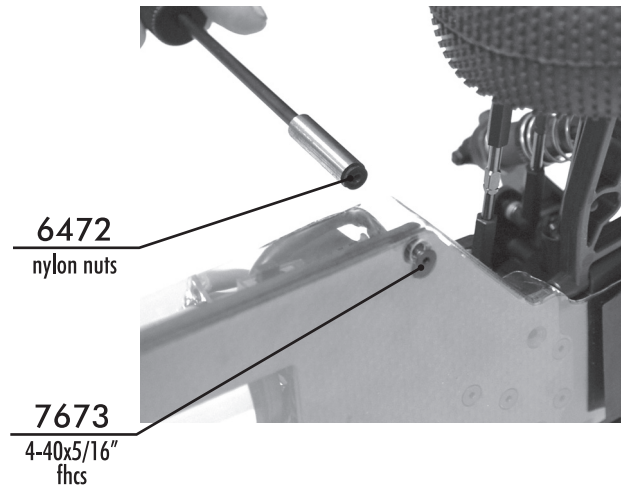
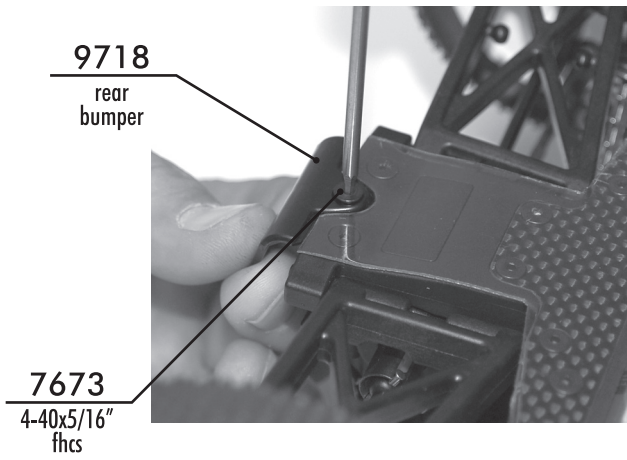

:: Body (cont.)

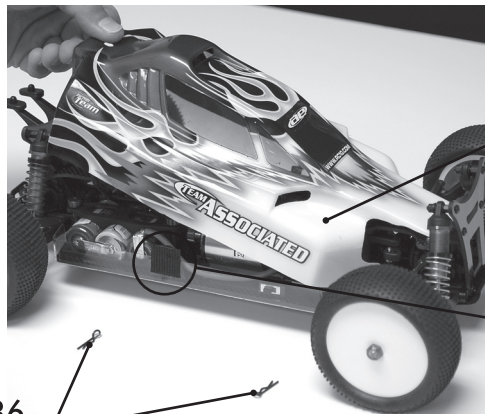

1736
small blue
body clips

1736
small blue
body clips

:: Notes

:: Tuning Guide

Recommended Motor Gearing:

| Motor | Pinion | Spur | (Final Drive Ratio):1 |
|--------------------|--------|------|-----------------------|
| 12-Turn Modified | 21 | 84 | 10.00 |
| 11-Turn Modified | 20 | 84 | 10.50 |
| 10-Turn Modified | 19 | 84 | 11.05 |
| 6.5 turn brushless | 19 | 84 | 11.05 |
| 5.5 turn brushless | 18 | 84 | 11.67 |

Gearing may vary due to track size.



Differential:

Adjust the differential (AKA 'diff' for short) as noted in the assembly instructions. Adjusting the diff is not meant to be a tuning option. If you can hear the diff making a "barking" or "chirping" sound on jump landings or under acceleration, either your diff is set too loose or your slipper clutch is set too tight.

Slipper Clutch:

The assembly instructions give you a base setting for your clutch. To preserve the differentials, always start with the slipper on the loose side and slowly tighten the adjustment nut until it is set. To adjust the slipper, remove the body and insert a 2mm (or 5/64") hex wrench through the center of the top deck (or through the bottom slot in the chassis). Then, grab both of the rear wheels and rotate forwards to tighten and backwards to loosen. As you spin the wheels, you'll feel the motor click every 1/4 of a wheel revolution. At the track, tighten or loosen the nut in 2 click increments until you hear only a faint slipping sound for 1-2 feet on takeoffs.

Front Camber Link Length & # of Washers under Ballstud:

Changing the length of the camber link is considered a bigger step than adjusting the ballstud height. Typically shortening the camber link (or lowering the ballstud) will give the front end less roll and quicken steering response. Lengthening the camber link (or raising the ballstud) will give the front more roll and slower steering response. To raise the ballstud, remove washers from between the ballstud and upper deck.

Front Camber:

A good starting camber setting is -1 degrees. Use the included #1719 camber gage to set your camber as seen below. Positive camber, where the top of the tire is leaning out, is typically not recommended.

Front Toe-In:

Zero degree toe-in (tires pointing straight forward) is the setting that should be used in almost all track conditions. Occasionally you can increase turn in by adding a little toe-out (front of tires point slightly out). Front toe in is not a typical tuning adjustment used by The Team.

Front Arm Hole:

The kit silver springs and outside front arm hole will work best in most cases. Moving the shock to the inside hole on the front arm requires you to add another down travel limiter to the front shocks, so there should be two down travel limiters in each shock. You should also change to a softer spring to account for the difference in leverage on the shock.

Front Ride Height:

The standard front ride height setting is 21mm. Check the ride height by lifting up the entire car about 8-12 inches off the bench and drop it. After the suspension "settles" into place, raise or lower the shock collars as necessary until there is 21 mm gap from the bottom of the chassis to the ground.

Anti-Squat:

Anti-squat denotes the angle of the rear arms relative to the ground. Zero anti-squat means that the rear arms are flat, parallel with the ground. The kit setting is 2 degrees, and can be reduced to 1 degree by removing the included #4 washer underneath the arm mount. You can add another #4 washer so that there is two washers underneath the arm mount to get 3 degrees of anti-squat. Adding anti-squat tends to make the car "rotate" more in corners, but doesn't handle as well through the bumps. 1 degree will be better in bumpy sections.

:: Tuning Guide (cont.)

Rear Camber Link Length & # of Washers under Ballstud:

Changing the length of the camber link is considered a bigger step than adjusting the ballstud height on the rear chassis brace. Typically shortening the camber link (or lowering the ballstud) will give the rear end less roll and the car will tend to accelerate or "square up" better. Lengthening the camber link (or raising the ballstud) will give the rear more roll and more cornering grip. To raise the ballstud, remove washers from in-between the ballstud and upper deck. You should normally use the kit setting and only adjust the ballstud height.

Rear Hub Spacing:

You have 3 options for rear hub spacing, FORWARD, MIDDLE, & BACK. The kit setting is FORWARD, which provides the most rear traction and will be used most often. For improved handling in bumps or rhythm sections, try moving the hubs to MIDDLE or BACK. This can also make the car handle better in 180° turns.

Rear Anti-Roll Bar:

The optional #9780 B44 anti-roll bar kit (a.k.a. swaybar) allows you to add roll resistance to the rear end with minimal effect on handling over bumps and jumps. The anti-roll bar is very helpful when trying to tune the suspension. The black bar is the softest (.047" wire) and the silver (.055" wire) is the heaviest. It is popular to run a rear anti-roll bar in 4wd to help the car square up more out of turns.

Rear Arm Hole:

The inner hole in the arm tends to work the best over the bumps and jump sections. Changing to the outer hole in the rear arm will tend to make the rear end feel more "locked in" and less responsive. Making this change to the outer hole requires you to remove the downtravel limiters from the rear shocks.

Rear Ride Height:

The rear ride height setting you should use most often is 21 mm (the rear arms appear level when looking from the rear). Check the ride height by lifting up the entire car about 8-12 inches off the bench and drop it. After the suspension "settles" into place, raise or lower the shock collars as necessary until there is 21 mm gap from the bottom of the chassis to the ground. Note: Check the ride height gap at the rear end of the carbon fiber chassis, not at the rear chassis plate which is raised for more ground clearance. The chassis should look level from the side.

Battery Setup:

The batteries for your B44 must be built to fit the car in a 3x3 configuration. We suggest building (as shown below) for ease of installation, charging and removal.

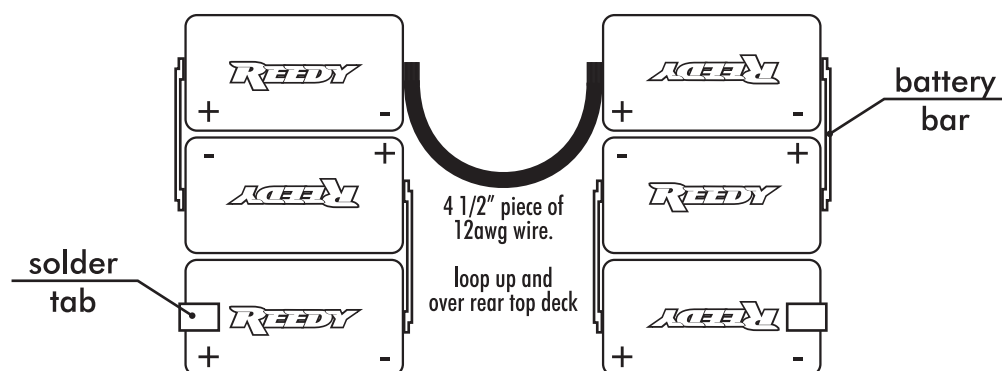

Setup Sheets:

Most often, the best way to get your car handling right is to go to our website www.rc10.com and click on the links to Setup Sheets, then RC10B44 setups. Our team of professional drivers help develop these setups at National events. Also, most drivers have a "base" setup that they use as a starting point for every event. Try running some of our base setups OR look for track conditions and tires that are similar to your local track and mimic that setup. Remember, each adjustment has a purpose, so copy everything from the setup sheet and then make adjustments based on the recommendations in here and in our online tuning guide at http://www.rc10.com/b44online_tuning_guide.

B44

:: **Driver:** Cavalieri, Maifield, Tebo :: **Date:** _____
 :: **Track:** Starting Setup
 :: **Event:** _____

Setup Sheet for Team Associated's B44

Rev. 1

:: Front Suspension

:: Rear Suspension

anti-roll bar:
 .047" - black
 .055" - silver

bumpsteer: 1 shim
 camber: -1 °
 toe: 0 °
 ride height: 21 mm

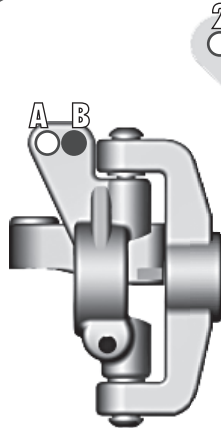

2
1

steering rack:
 back
 front

washers: 2

2
1

notes: _____

anti-roll bar:
 .047" - black
 .055" - silver

camber: -1 °
 toe: 3 °
 ride height: 21 mm

wheelbase:
 long
 medium
 short

anti-squat washers: 1

2
1

A B C

washers: 2

2
1

notes: _____

:: Front Shocks

spring: silver piston: #2
 shock fluid: 35 wt limiters: 1

:: Rear Shocks

spring: green piston: #1
 shock fluid: 25 wt limiters: 1

:: Differentials

front setting: std
 rear setting: std

:: Wing

type: stock
 angle: 3° 6° 9°

:: Electronics

motor: LRP X11 6.5turn
 gearing: 19/84
 esc: LRP2007 SC setting: 2.2.1.1

:: Front Tires

tire: Holeshot
 compound: M3
 insert: _____
 wheel: stock

:: Rear Tires

tire: Holeshot
 compound: M3
 insert: _____
 wheel: stock

:: Race and Vehicle Comments





qualify: _____ main: _____ finish: _____ tq:
 comments: _____

:: Track Info





smooth: bumpy: blue groove:
 traction: high med. low
 soft dirt: grass: clay: wet:
 dusty: other: _____

:: Hardware - 1:1







cap head (shcs)

-  4-40x3/8" (6924)
-  4-40x7/16" (7874)
-  4-40x1/2" (6925)
-  4-40x7/8" (7738)
-  3x6mm (6515)







flat head (fhcs)

-  4-40x5/16" (7673)
-  4-40x3/8" (6292)
-  4-40x7/16" (9765)
-  4-40x5/8" (6915)





button head (bhcs)

-  2-56x1/8" (9645)
-  2-56x5/16" (4334)
-  4-40x1/4" (6228)
-  4-40x3/8" (6917)
-  4-40x7/16" (2221)
-  4-40x3/4" (7413)



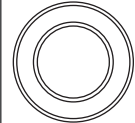

shims & washers

-  ballstud washer (9630)
-  .030" nylon spacer (4187)
-  servo mount washer (7337)
-  #4 washer (6936)
-  input shaft shim - black (3911)
-  3/16" axle shim - silver (7368)
-  outdrive shim (3911)



ball bearings

-  steering bearing (9746)
-  3/16x5/16" (6909)
-  3/16x3/8" RS (3977)
-  3/16x1/2" RS (7935)
-  3/8x5/8" RS (3976)

nuts (lock/plain)

-  4-40 aluminum locknut (4449)
-  4-40 plastic nut (6472)
-  5-40 nylon locknut (9744)
-  8-32 LP nylon locknut (3438)
-  8-32 nylon locknut (6943)

diff balls

-  5/64" diff thrust balls (6574)
-  3/32" carbide diff balls (6581)

top hat bushings

-  small top hat bushing (3874)
-  large top hat bushing (9647)

notes

B44

:: Driver: _____ :: Date: _____
 :: Track: _____
 :: Event: _____

Setup Sheet for Team Associated's B44

Rev. 1

:: Front Suspension

:: Rear Suspension

anti-roll bar:
 .047" - black
 .055" - silver

anti-roll bar:
 .047" - black
 .055" - silver

bumpsteer: _____
 camber: _____ °
 toe: _____ °
 ride height: _____ mm

camber: _____ °
 toe: _____ °
 ride height: _____ mm

steering rack:
 back
 front

washers: _____

anti-squat washers: _____

washers: _____

notes: _____

notes: _____

:: Front Shocks

:: Rear Shocks

spring: _____ piston: _____
 shock fluid: _____ limiters: _____

spring: _____ piston: _____
 shock fluid: _____ limiters: _____

:: Differentials

:: Wing

:: Electronics

front setting: _____
 rear setting: _____

type: _____
 angle: 3° 6° 9°

motor: _____
 gearing: ____/____
 esc: _____ setting: _____

:: Front Tires

:: Rear Tires

tire: _____
 compound: _____
 insert: _____
 wheel: _____

tire: _____
 compound: _____
 insert: _____
 wheel: _____

:: Race and Vehicle Comments

:: Track Info

qualify: _____ main: _____ finish: _____ tq:
 comments: _____

smooth: bumpy: blue groove:
 traction: high med. low
 soft dirt: grass: clay: wet:
 dusty: other: _____



Associated Electrics, Inc.
26021 Commercentre Dr.
Lake Forest, CA 92630 USA