

PROSC 4x4

#7062 ProSC 4x4 RTR

READY-TO-RUN

BRUSHLESS POWERED ELECTRIC SHORT COURSE TRUCK



1:10 Scale Electric 4WD Short Course Truck Manual & Catalog

QUALIFIER

S E R I E S

TEAM ASSOCIATED

:: Introduction

Thank you for purchasing this Team Associated Qualifier Series product. This manual contains instructions and tips for maintaining your new Pro SC 4x4 RTR. Please take a moment to read through it and familiarize yourself with these steps as they will help you to understand each component's function and show you some tips for getting the most out of your Pro SC 4x4 RTR. We are continually changing and improving our designs; therefore, actual parts may appear slightly different than the illustrations.

For more information, scan the QR code to the right for videos and tutorials on the Pro SC 4x4 RTR!



http://www.teamassociated.com/cars_and_trucks/Pro_SC_4x4/

:: Pro SC 4x4 Platform Features

- Ready-To-Run shaft drive 4wd Short Course truck
- Reedy 550-SL 3500kV 4-Pole Brushless Motor
- Splash-proof Reedy SC800-BL brushless speed control with High Current T-plug Connector (2S-3S LiPo compatible)
- Reedy WolfPack 3000mAh 8.4V NiMH Battery with High Current T-plug Connector
- XP 2.4Ghz Radio system with XP Metal Gear steering servo
- Factory painted and decaled Short Course body, available in two color combinations
- 16mm 'Big Bore' composite fluid filled shocks
- 15-spoke off road hex drive wheels with high-grip racing tires
- Short Course style front and rear bumpers and improved adjustable body mounts
- Upgraded CVAs and rear dog bones for improved durability
- Heavy duty gear differentials, aluminum drive shaft, and center slipper clutch
- Composite modular chassis with enclosed water-resistant receiver box
- All metric hardware, adjustable steel turnbuckles, and ball bearings throughout

:: Additional Items Needed

Your Pro SC 4x4 RTR requires the following items to complete your kit:

- Transmitter batteries (x6 AA) (#302 recommended)
- Battery charger (peak detection charger recommended) (AE #610) -OR- Wall charger (#29154)

:: Other Helpful Items

- Silicone Shock Fluid / Differential Fluid (Refer to catalog for complete listings)
- Body Scissors (AE Part # 1737)
- FT Hex Wrenches (AE Part # 1541, 1655)
- FT Nut Drivers (AE Part # 1561, 1663-1668)
- FT Turnbuckle Wrench (AE Part #1112)
- Green Slime shock lube (AE Part # 1105)
- Needle nose pliers
- Ride Height Gauge (#1449 recommended)
- FT Threadlock (AE Part # 1596)
- Multi Tool (AE Part # 7494)
- Calipers or a Precision Ruler
- Soldering Iron
- Wire cutters
- Reamer/hole punch
- Hobby knife

Associated Electrics, Inc.
 26021 Commercentre Dr.
 Lake Forest, CA 92630



Customer Service
 Tel: 949.544.7500
 Fax: 949.544.7501

:: Table of Contents

1.....Cover	13-14.....Front Diff Access
2.....Introduction	14.....Diff Maintenance
3.....Table of Contents	14-15.....Shock Maintenance
4.....Blueprint of a Pro SC 4x4	16.....Motor Manual
5-7.....Quick Start Guide	17.....ESC Manual
8.....Radio, Speed Control Wiring	18-27.....Catalog
9.....Gear Mesh & Ride Height	28.....1:1 Hardware "Fold Out"
10.....Camber & Toe Settings / Slipper Adjustment	29.....Optional Tools / Contact Info
11-12.....Spur Gear Access / Rear Diff Access	30.....Trouble Shooting

:: Notes



This symbol indicates a special note or instruction in the manual.



There is a 1:1 hardware foldout page in the back of the manual. To check the size of a part, line up your hardware with the correct drawing until you find the exact size. Each part in the foldout has a number assigned to it for ordering replacement parts.

Associated Electrics, Inc.
26021 Commercentre Dr.
Lake Forest, CA 92630



Customer Service
Tel: 949.544.7500
Fax: 949.544.7501

:: Blueprint of a Pro SC 4x4

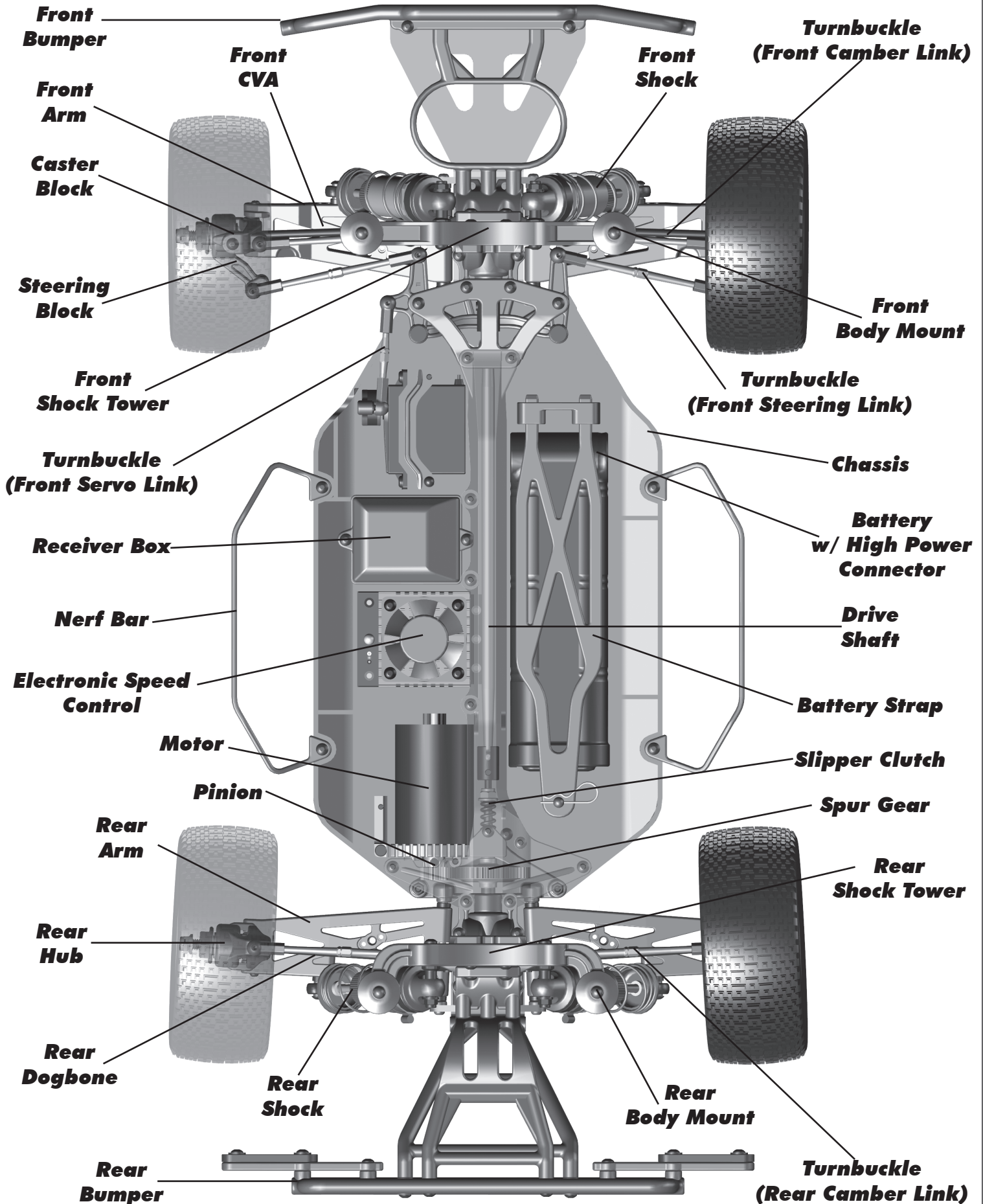

:: Quick Start Guide

Battery Charging Steps and Safety:

NiMH Wall Charger: (Part #29154 - Wall Charger AC 120V 350mAh)

NiMH Quick Charger: (Part #610 - Reedy 447-S AC/DC 4-7 Cell Peak Prediction NiMH/NiCd Charger)

Remove the battery from the vehicle before charging. Be sure to select the correct charging mode for the type of battery you are charging.

NEVER leave the battery unattended while charging!

NiMH: NiMH batteries (nickel-metal hydride) are high current rechargeable batteries. If you use a peak detection charger, make sure it is designed for NiMH batteries!



Wall Charger



Peak Detection Quick Charger

:: Quick Start Guide - (cont.)

Battery Installation:

1. Install the battery with the battery wires directed towards the rear of the vehicle.
2. Insert the tabs of the battery strap into the battery wall.
3. Slide the opposite side of the battery strap onto the battery post and secure with a body clip.

You may move the foam pad to either the front or the rear of the battery compartment to adjust the weight balance of the vehicle.



:: Quick Start Guide - (cont.)



:: Quick Start Guide - (cont.)

Throttle Calibration:

- 1) Set your radio's throttle and brake EPA/ATV to 100% and your throttle trim to neutral. Then turn on your transmitter.
- 2) Press and hold the SET button while powering ON the ESC. When the LED begins to flash, release the SET button immediately.
- 3) With the throttle trigger at neutral, press the SET button to save the neutral position verified by one flash of the LED.
- 4) Move the throttle trigger to the full throttle position and press the SET button to save the full throttle position verified by two flashes of the LED.
- 5) Move the throttle trigger to the maximum brake position and press the SET button to save the maximum brake position verified by three flashes of the LED.
- 6) Return the throttle trigger to the neutral position. After three seconds, the ESC will automatically exit the calibration procedure and the ESC is ready to use.

Green LED = LiPo Mode

Red LED = NiMH Mode

SWITCHING BETWEEN LIPO AND NIMH BATTERY MODES

A choice of either LiPo mode or NiMH mode activates the low voltage cutoff point. This is particularly important when using LiPo batteries that should not, for performance and safety reasons, be discharged below 3.2V per cell. In LiPo mode, the ESC detects whether you are using 2 or 3 cells and adjusts the cutoff accordingly. The color of the LED at neutral throttle indicates which mode the ESC is currently in. When in LiPo mode, the LED will be green. When in NiMH mode, the LED will be red. Regardless of which mode the ESC is in, the LED will always blink red when the Low Voltage Cutoff Protection is activated and flash green when the Thermal Protection is activated.

LiPo-->NiMH: With the transmitter and ESC powered ON and the throttle trigger in the neutral position, press and hold the SET button (approximately two seconds) until the green LED begins to flash. Continue to hold the SET button (approximately four more seconds) until the LED begins to flash red indicating a successful switch. Now release the SET button. The red LED will continue to flash (approximately four seconds) and then remain solid red. The ESC has successfully been switched from LiPo mode to NiMH mode and the ESC is ready to use.

NiMH-->LiPo: With the transmitter and ESC powered ON and the throttle trigger in the neutral position, press and hold the SET button (approximately two seconds) until the red LED begins to flash. Continue to hold the SET button (approximately four more seconds) until the LED begins to flash green indicating a successful switch. Now release the SET button. The green LED will continue to flash (approximately four seconds) and then remain solid green. The ESC has successfully been switched from NiMH mode to LiPo mode and the ESC is ready to use.

Note: Continuing to press the SET button after successfully switching modes will switch the mode again. Releasing the SET button after the appropriate flashing LED color confirms the mode selection.

WARNING: FAILURE TO SELECT LIPO MODE WHEN USING LIPO BATTERIES MAY RESULT IN PERMANENT DAMAGE TO THE BATTERY AND/OR FIRE.

1



Push for Brake

Pull for Throttle

Neutral Throttle set to Neutral when turning on the radio !

:: Quick Start Guide - (cont.)

Battery Notes and Tip:

Plug the battery in as shown. Unplug battery when not in use! There are two types of batteries you can use with this vehicle. NiMH (nickel-metal hydride) and LiPo (lithium polymer).

LiPo: LiPo batteries (lithium polymer) are high current rechargeable batteries. LiPo batteries offer extended run time and peak performance over NiMH batteries. They require a peak detection charger designed specifically for LiPo batteries.

LiPo/LiFe Charger: (Part # 604 - Reedy 526-S AC/DC 2S-6S Cell LiPo/LiFe Balance Charger)

These batteries require special care and handling.

LiPo batteries are recommended for advanced users only!

ALWAYS charge a LiPo battery in LiPo mode.

CAUTION! If using a LiPo battery, you need to change the speed control settings to LiPo mode (see page 17 for instructions).

If using a 3S LiPo battery, you must use a smaller pinion gear (use part #91164 13T Pinion). This will give you the correct gear ratio for the extra power the 3S LiPo battery will deliver.

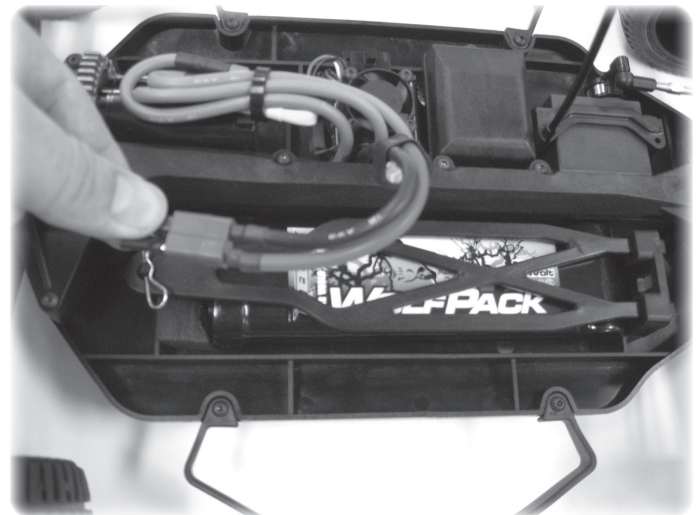

:: Quick Start Guide - (cont.)

Radio System Tuning and Controls:

RULE: Transmitter on First/Vehicle on Second, Vehicle off First/ Transmitter off Last!

- 1) Slide the battery cover in the direction shown to remove cover.
- 2) Install six (6) alkaline or rechargeable AA size batteries into the battery holder.
- 3) Slide the battery cover back into place making sure it is completely closed and secure.
- 4) Turn the power ON. If the power indicator LED fails to light, check the batteries for insufficient contact or incorrect polarity.

While pressing this part

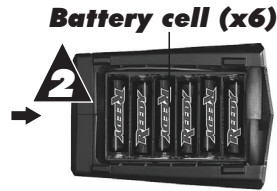
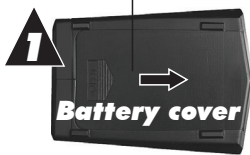

On/Off Switch

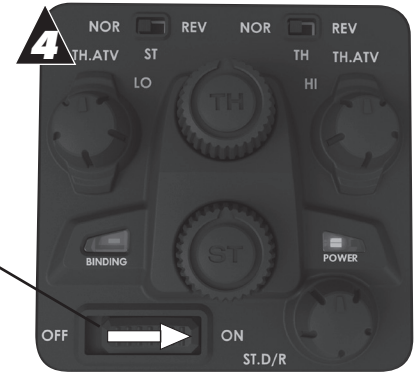

:: Quick Start Guide - (cont.)

Radio System Tuning and Controls:

DO NOT hold the trigger when turning on the radio.

If using optional battery for transmitter, be sure to plug it in correctly. Plugging in a battery backwards can cause damage.

Refer to Radio owners manual for more in-depth instructions on radio operation and functions.



Throttle set to Neutral when turning on the radio !

:: Quick Start Guide - (cont.)



Adjust steering trim so front wheels point straight.

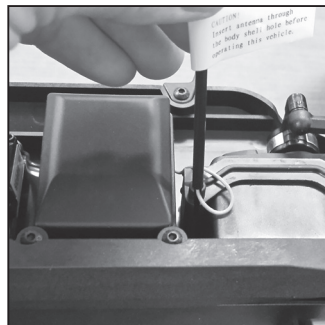

Install antenna wire through antenna tube, then install antenna tube as shown.

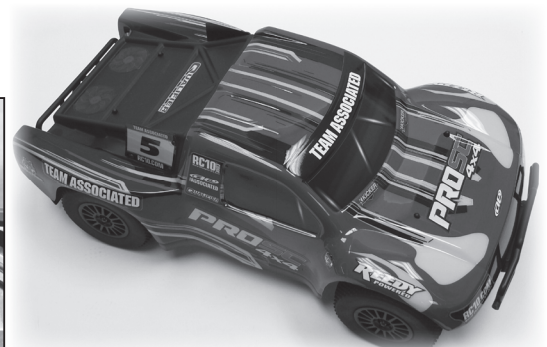

Install body and body clips. Ready to go!

:: Wiring Diagrams

Receiver Box Gasket Maintenance:

1. Apply a small amount of "hobby grade" glue to the top edge of the receiver box in order to hold the receiver box gasket in place. Do the same for the receiver box lid. Make sure not to get glue on the side of the gaskets that will make contact with each other!

Wait until the glue has completely dried before moving on to the next step!

2. Once the receiver box gasket is installed, you can then plug your servo and speed control into your receiver. You can also run your receiver's antenna wire into the antenna tube. Once this is done, you can now install the radio box lid. The gasket attached to the receiver box and the gasket attached to the receiver box lid will squeeze against the servo, speed control, and antenna wires.

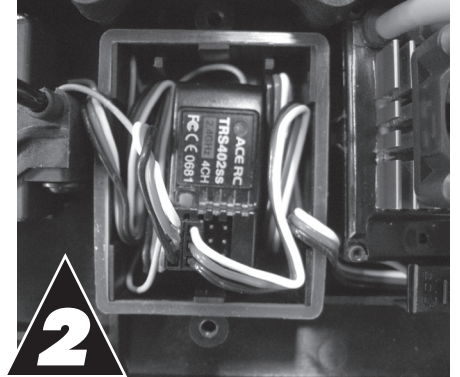
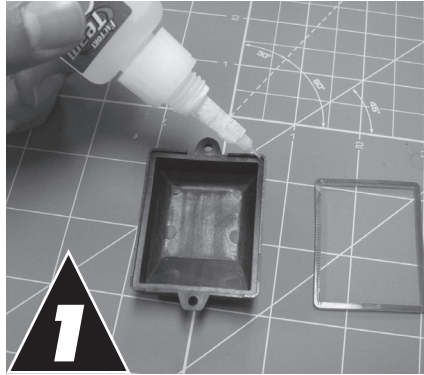

:: Wiring Diagrams

Motor and Receiver Wiring:

1. If motor runs in reverse when you apply throttle, unplug any two of the motor wires and switch them.
2. Your Receiver has multiple channel ports for plugs.

Channel 1 - you should always plug your steering servo into this channel port.

Channel 2 - you should always plug your speed control (ESC) into this channel port.

Channel 3 - Used for optional equipment such as fans, lights, ect...

Batt - Used for optional receiver battery pack. Not used in this model.

Negative black wires on steering servo and speed control plugs should face the outside edge of receiver where channel markers are located.

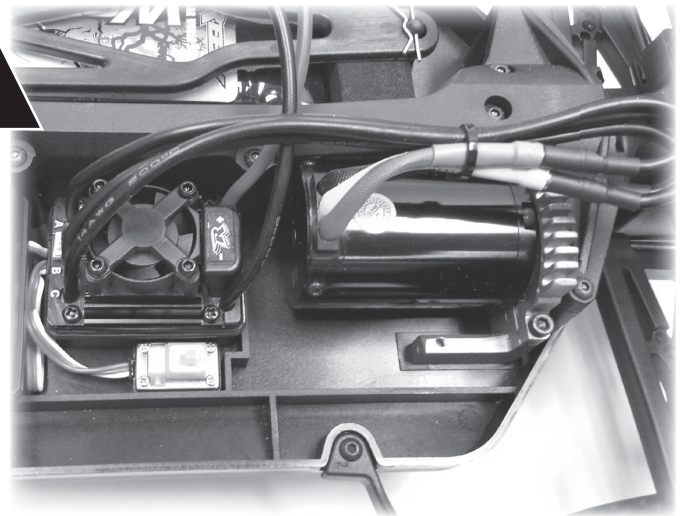

:: Wiring Diagrams - (cont.)

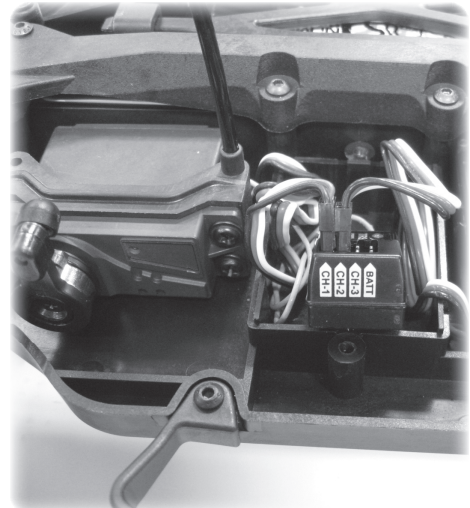
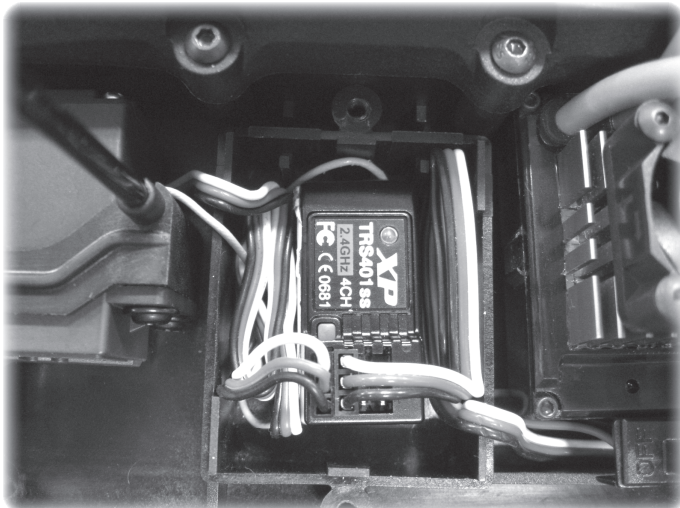

:: Gear Mesh

Gear Mesh:

To correctly set your gear mesh, follow the steps below:

1. Remove the Chassis Brace. Loosen the set screw on the motor's pinion gear. Slide the pinion on the motor shaft until the gear face of the pinion is entirely aligned with the gear face of the spur gear (see diagram). Tighten the set screw while ensuring it is aligned with the flat face on the motor shaft.

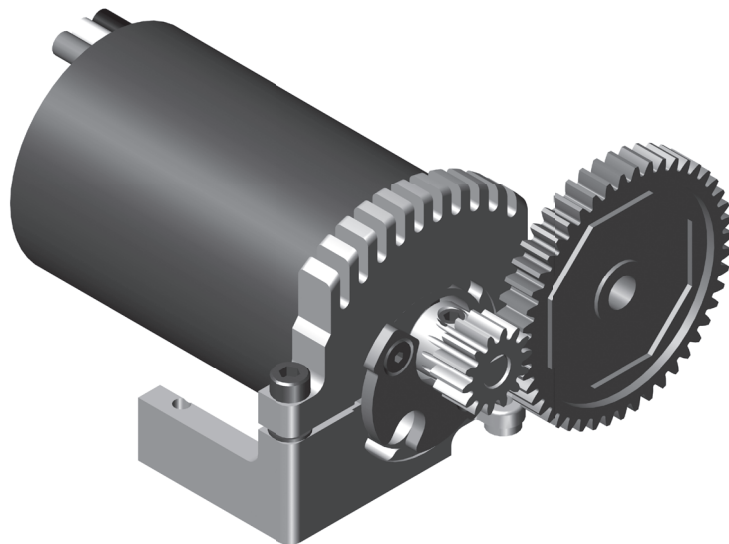
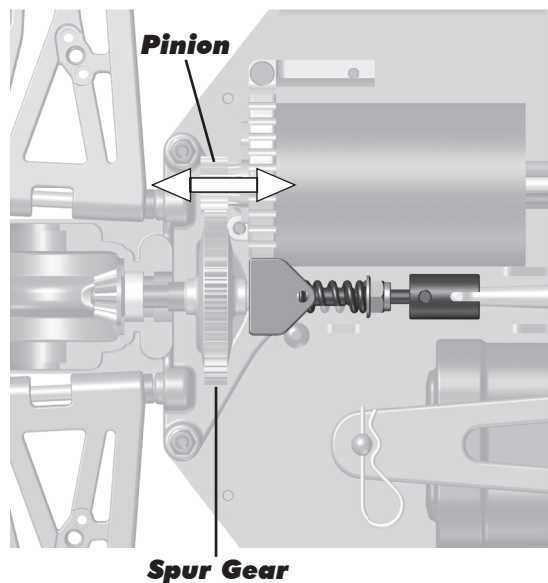

2. Loosen the motor clamp screw until the motor is able to move freely. Rotate the motor as far as it can go towards the spur gear, ensuring that the teeth of the pinion and the spur gear are interlocking. Slide the motor back (approximately 0.5 mm), and tighten the motor clamp screw. Proper gear mesh has been achieved when the teeth are meshing closely, but the gears still have a small amount of clearance between them. If you hold one gear, you should be able to rock the other gear back and forth a small amount. If there is no clearance, your gear mesh is too tight and you should readjust the motor again.

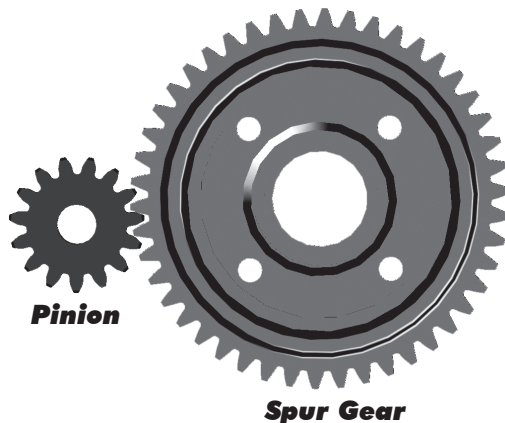

:: Ride Height

Adjusting Ride Height:

Ride height is adjusted by adding and/or removing shock pre-load clips to the front and rear shocks. Stock setting is approximately 35mm front and rear. Check the ride height with the FT Ride Height Gauge (# 1449) by lifting up the entire vehicle about 8-12 inches off the bench and drop it. After the suspension "settles" into place, then raise or lower the ride height with the shock clips as necessary and recheck. Getting the front and rear arms level is a good starting point.

Kit Settings:
Front shock: 2mm
Rear shock: 12mm

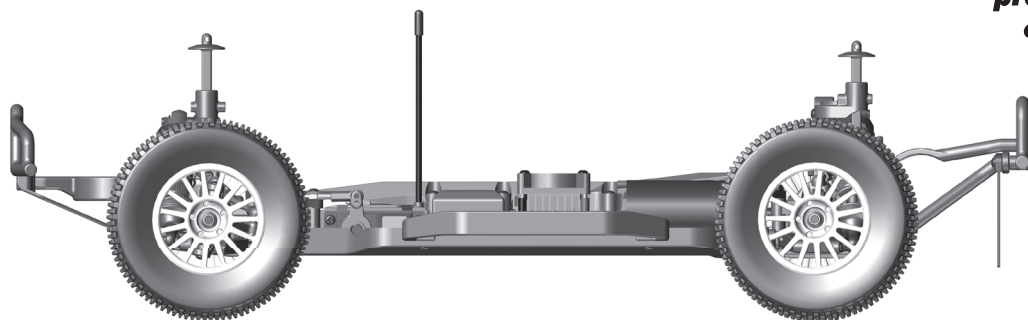
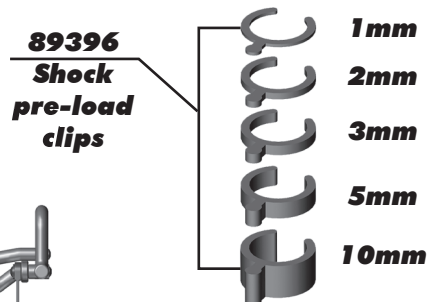

:: Camber / Toe

Front Camber Angle:

A good starting camber setting is -2 degrees (where the top of the tires lean inwards). Positive camber, where the top of the tire is leaning out, is typically not recommended.

Front Toe-In:

Zero degree toe-in (tires pointing straight forward) is a good starting setting. You can increase steering into corners by adding 1-2 degrees of toe-out (front of tires point slightly outward). Front toe-in is not a typical tuning adjustment used.

Rear Camber:

A good starting camber setting is -2 degrees. Use # 1719 camber gauge (not included) to set your camber. Adding a small amount of positive camber, where the top of the tire is leaning out, will tend to improve straight-line acceleration on loose tracks.

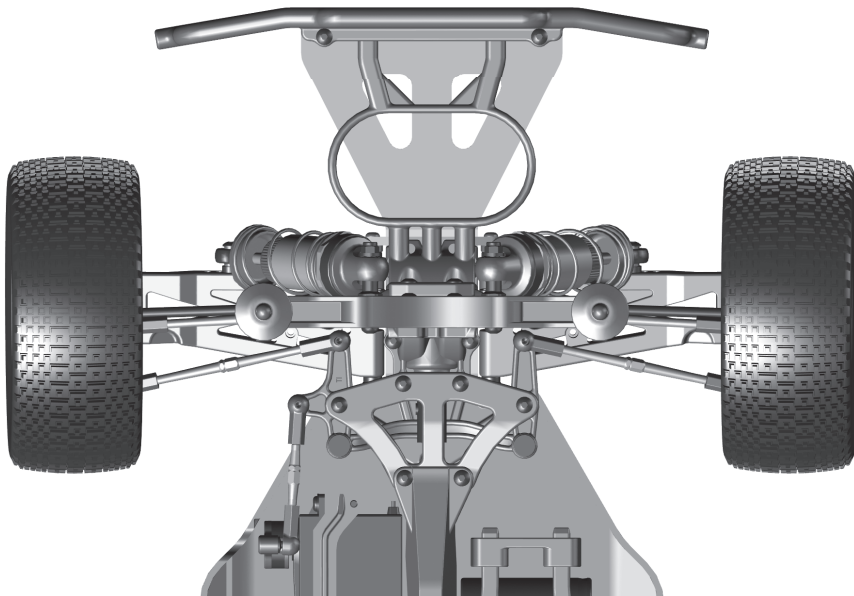

:: Body Post Adjustments

Body Post Trimming:

When adjusting body post height, you may need to trim the body posts to clear the rear shocks. Check for clearance by compressing the suspension arm and look for interferences.

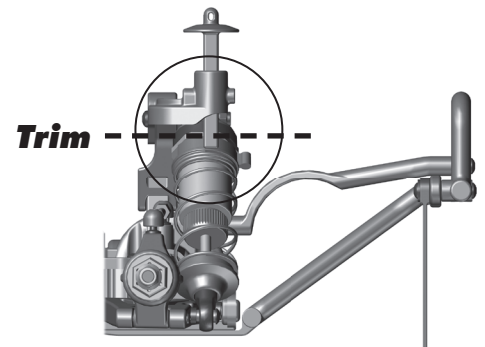

:: Slipper Adjustments

Adjusting the Slipper:

To adjust the slipper, use a 7mm open end wrench or some pliers to grip the slipper nut. Roll the vehicle forward to tighten the slipper; roll the vehicle backwards to loosen the slipper.

TIP: for easier slipper adjustment, remove the chassis brace, battery brace, and battery as shown!

3.5mm-4.0mm of thread showing

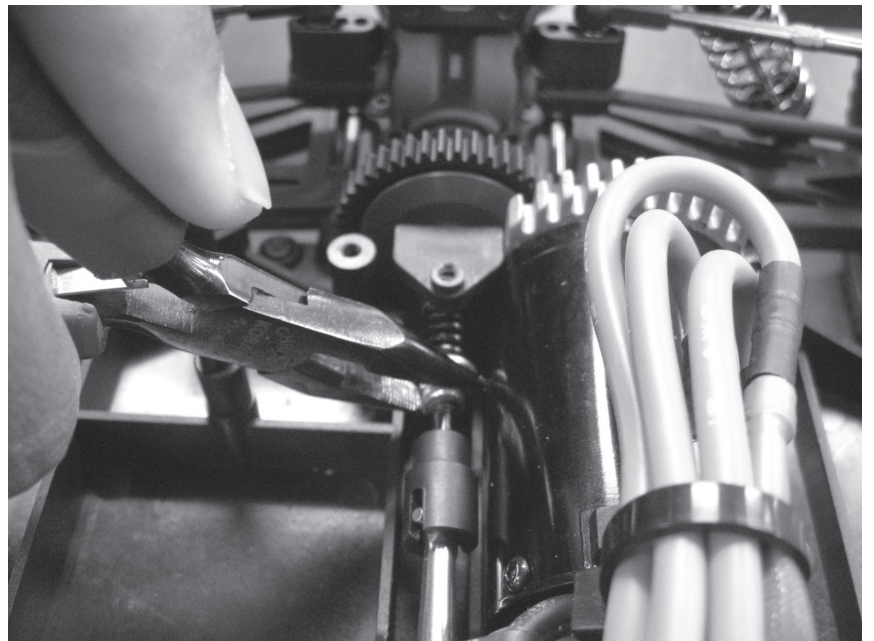
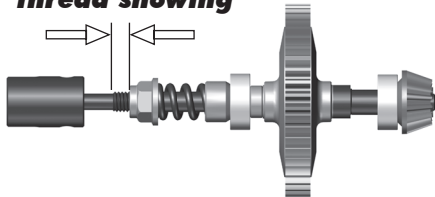

:: Spur Gear Access

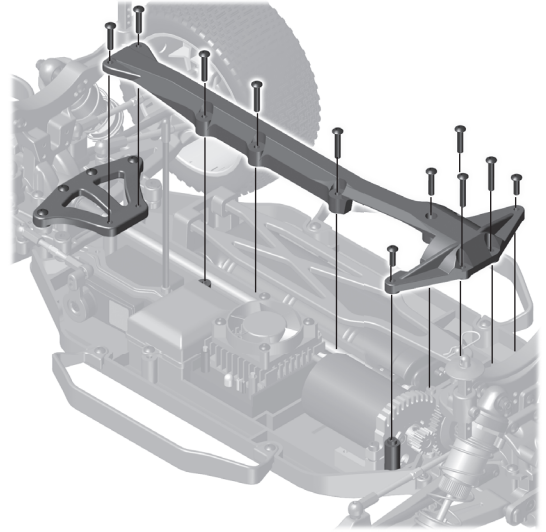
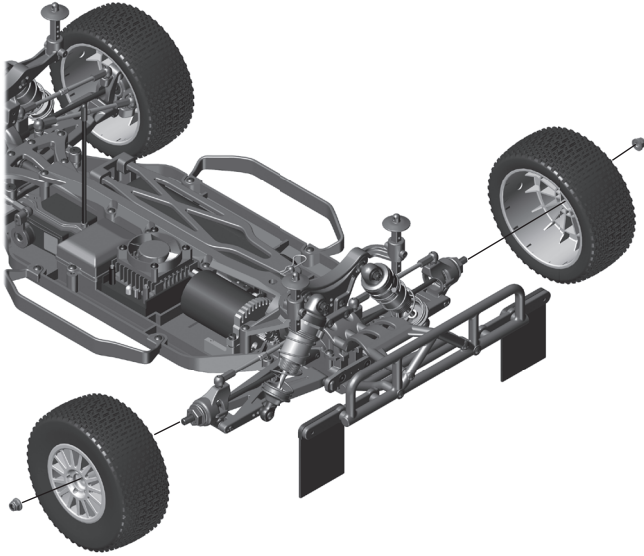

:: Spur Gear Access - (cont.)

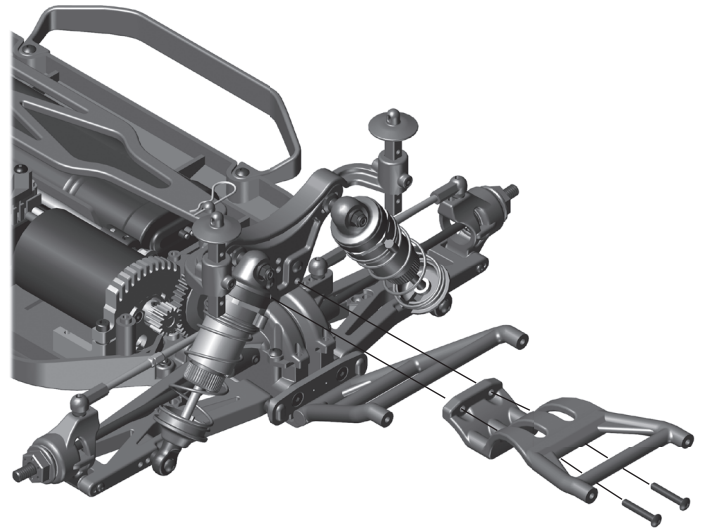
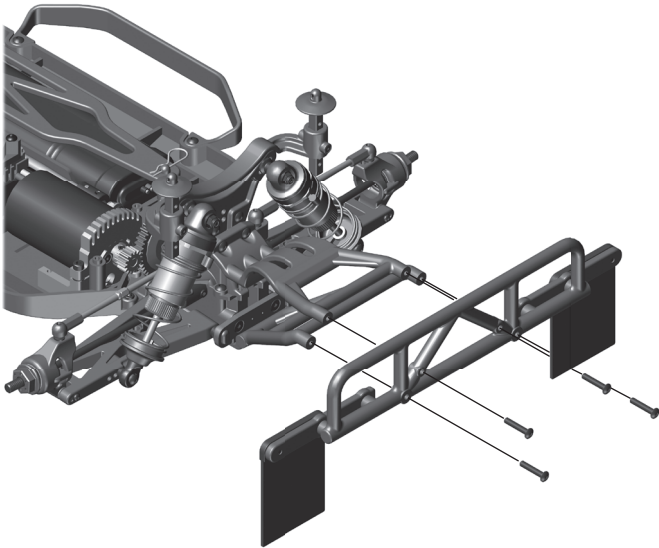

:: Spur Gear Access - (cont.)

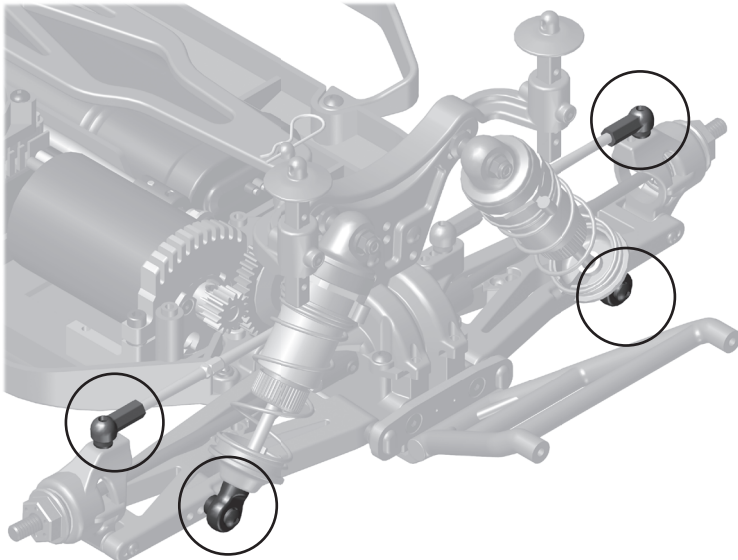

Rear Shock Tower Removal:

Loosen the hardware highlighted in order to remove the shock tower with the shocks and camber turnbuckles attached as one complete piece.

The dogbones will come out when the shock tower is removed. Make sure you replace them when re-installing the rear shock tower!

:: Spur Gear Access - (cont.)

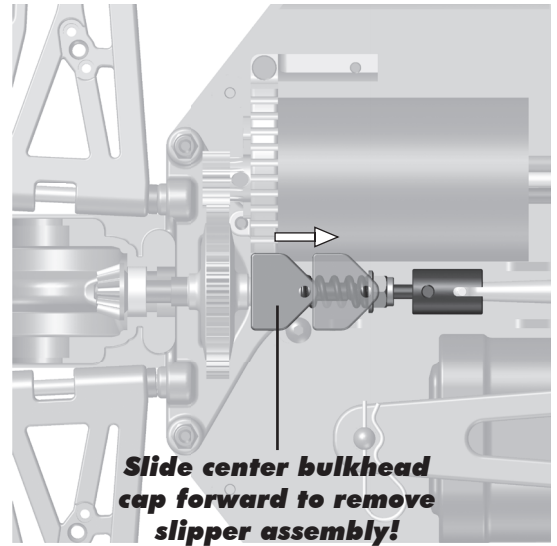
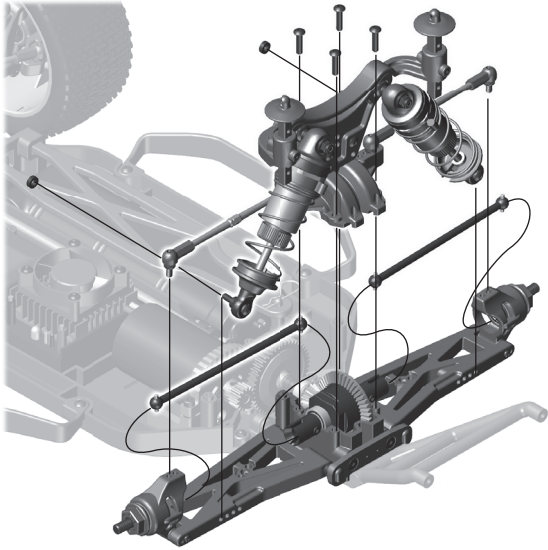

Slide center bulkhead cap forward to remove slipper assembly!

:: Spur Gear Access - (cont.)

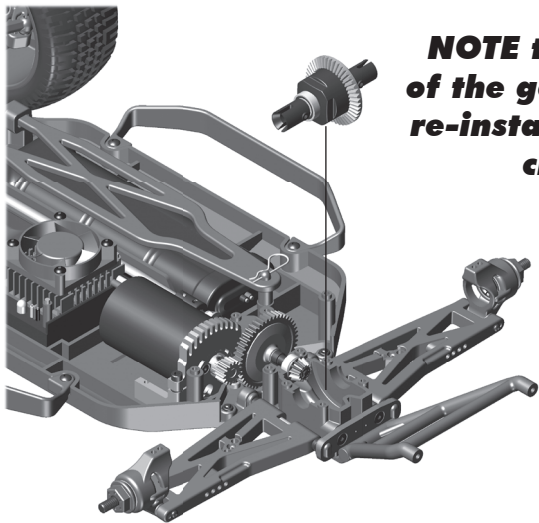

NOTE the direction of the gear diff when re-installing into the chassis!

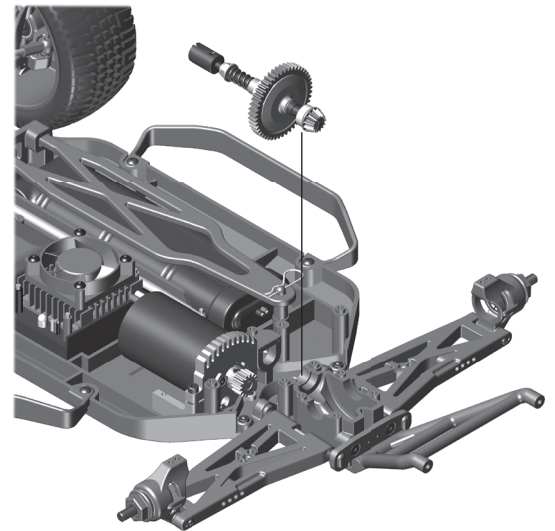

:: Spur Gear Access - (cont.)

Spur Gear Maintenance:

When accessing your spur gear, check for wear on the teeth of the gear. The teeth should be nice and sharp. Also, check the slipper pads for wear. Replace if necessary.

A good starting point for slipper setup is to have 3.5 to 4.0mm of thread showing on the shaft.

3.5mm-4.0mm of thread showing

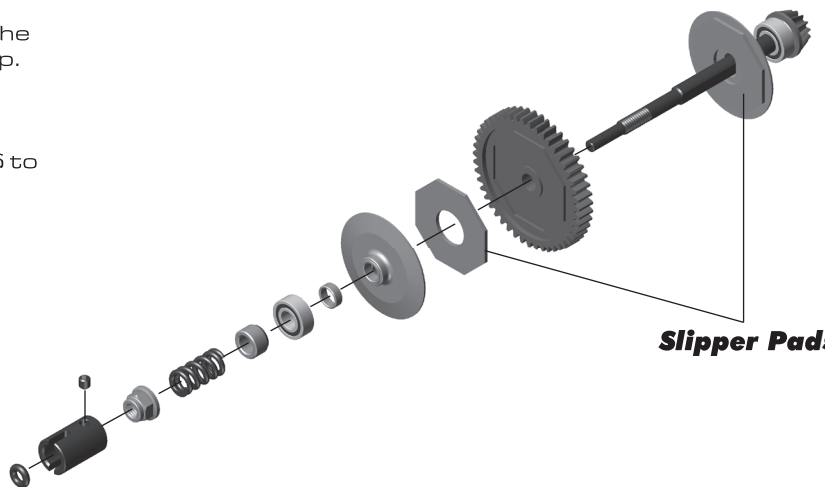
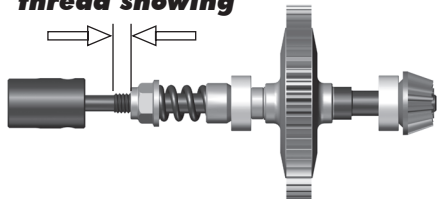

Slipper Pads

:: Front Diff Access

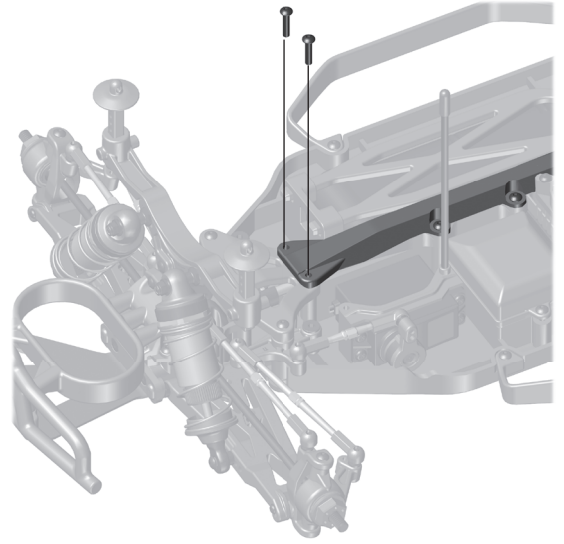
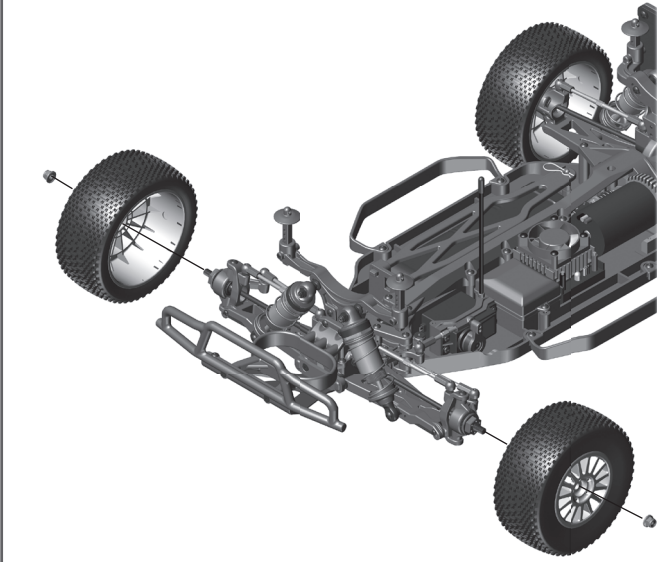

:: Front Diff Access - (cont.)

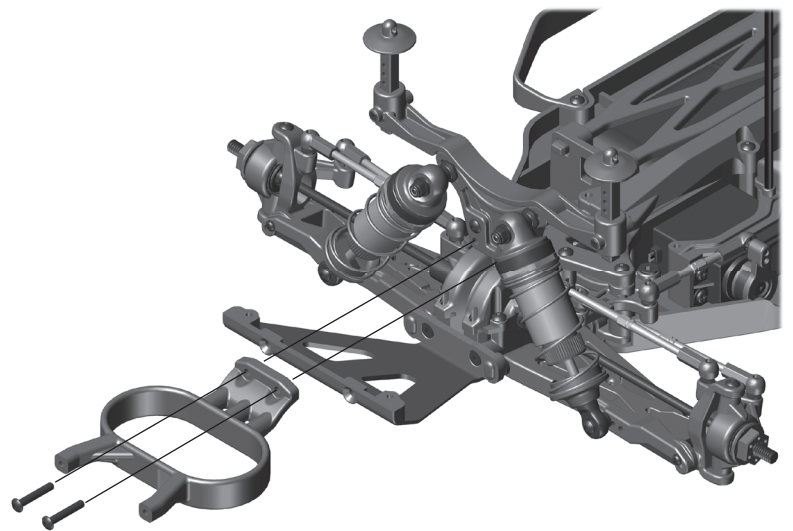
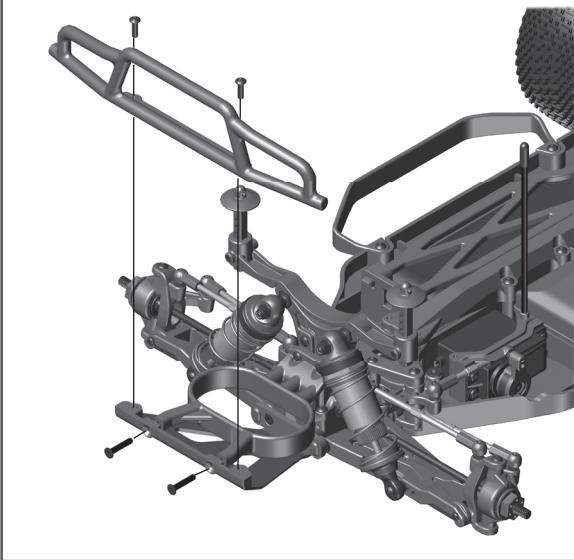

:: Front Diff Access - (cont.)

Front Shock Tower Removal:

Loosen the hardware highlighted in order to remove the shock tower with the shocks and camber turnbuckles attached as one complete piece.

Make sure you re-install the CVA bones into the diff outdrives when re-installing the front shock tower!

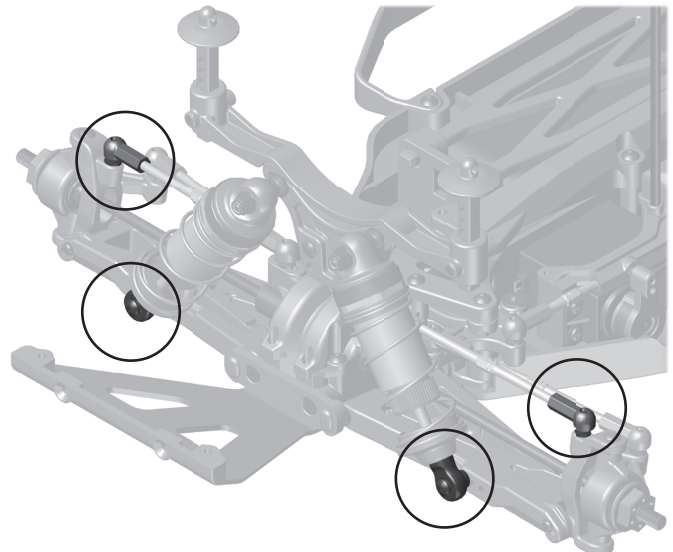

:: Front Diff Access - (cont.)

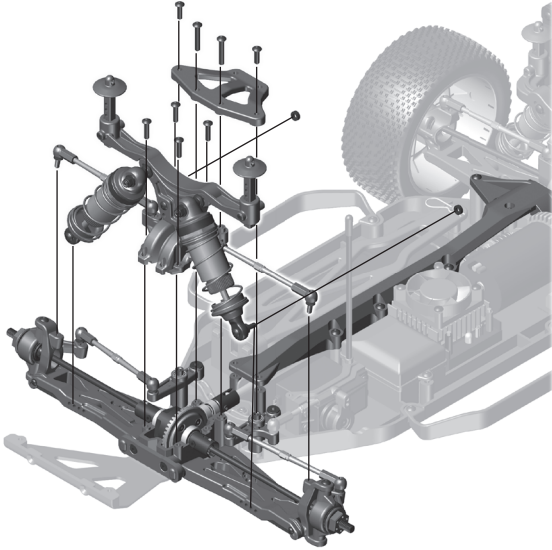

NOTE the direction of the gear diff when re-installing into the chassis!

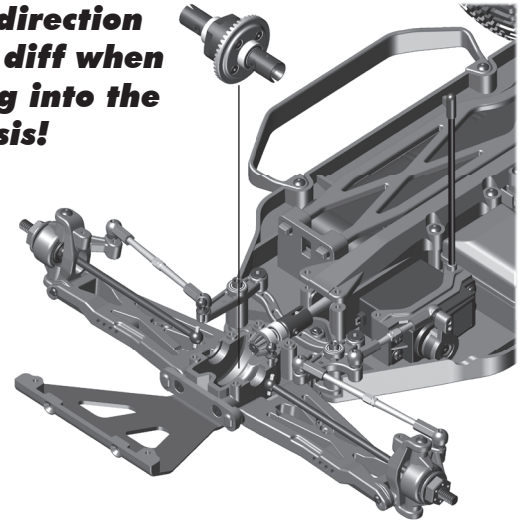

:: Diff Maintenance

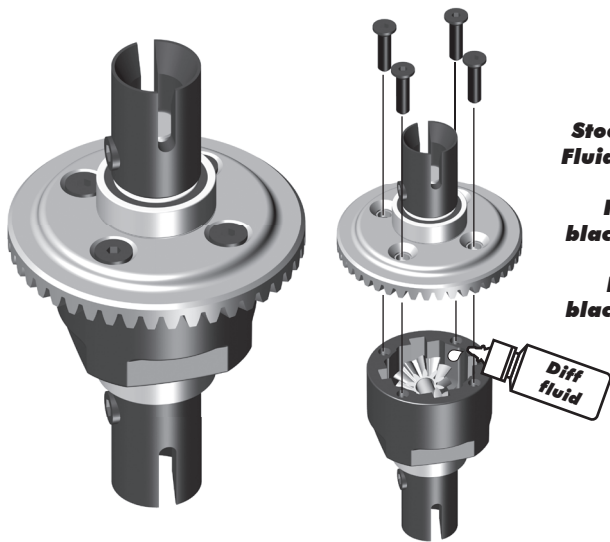

Stock Shock Fluid Setting:

Front:
black grease

Rear:
black grease

Differential Maintenance:

Once you have removed the Diff gear, you can now drain the existing diff fluid from the differential.

Check the diff gasket for wear or damage. Replace if necessary

Fill the diff to the top of the cross pin with your choice of diff fluids.

Front Diff:

Thicker oil will get less low speed steering and better acceleration out of turns.

Rear Diff:

Thicker oil will rotate less in the turns and accelerate straight on power. Thinner oil will give more low speed traction.

:: Shock Maintenance

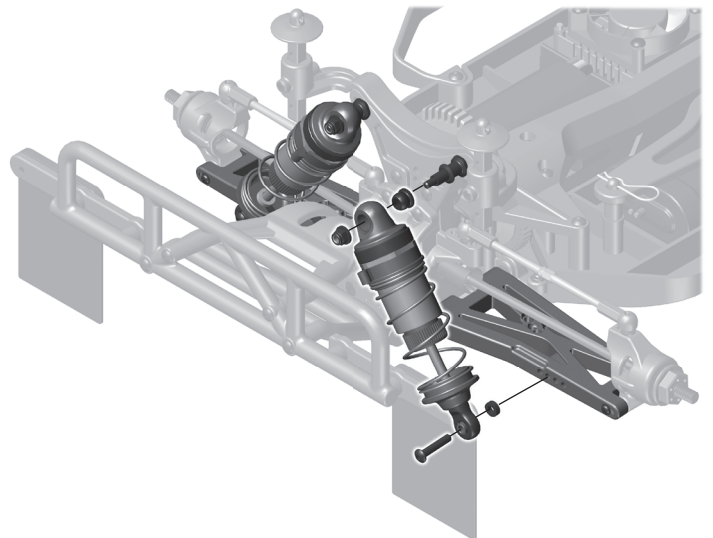
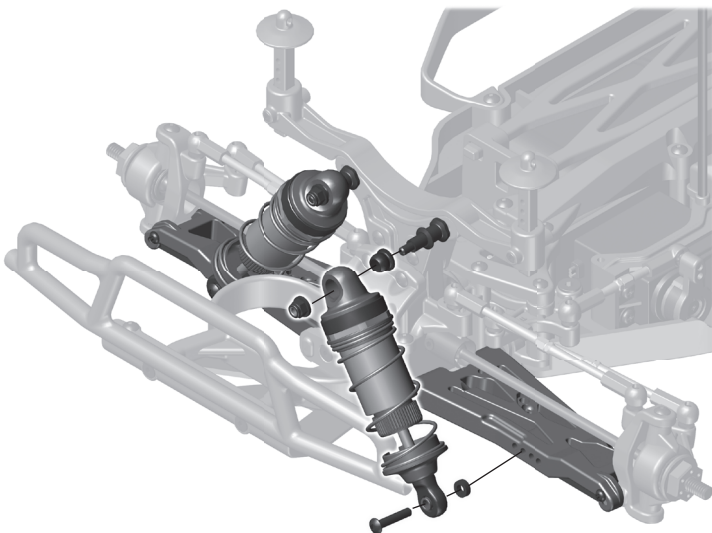

:: Shock Maintenance - (cont.)

Shock Maintenance:

If you need to only refill your shocks with oil, follow the steps above only then move to the shock bleeding steps.

If your shocks leak from the bottom shock cap, follow all shock maintenance sections.

Replace the inner O-Ring in the bottom cap, then begin the shock oil filling and bleeding process.

NOTE:

When re-installing the shock spring cup, make sure any outer limiters go above the shock spring cup!

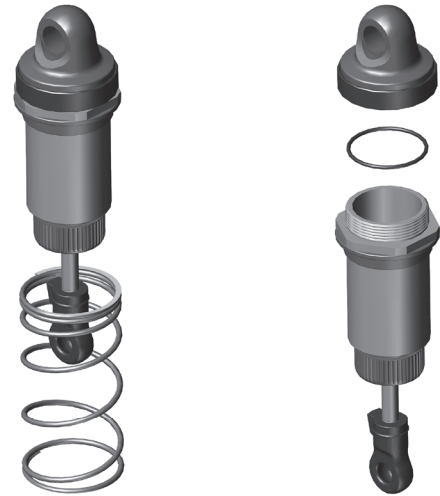
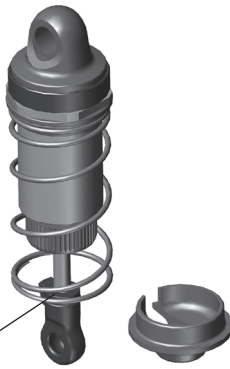

:: Shock Maintenance - (cont.)

Stock Shock Internal Limiter Setting:

Front:
One 1mm limiter
Four 2mm limiters

Rear:
No limiters

Stock Shock External Limiter Setting:

Front:
No limiters

Rear:
One 2mm limiter

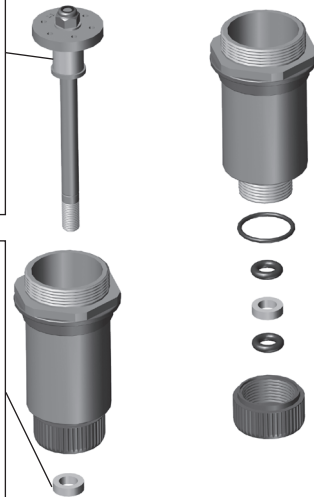

Filling Your Shocks:

A) Add a drop or two of shock fluid to the shock cap O-ring and shock body threads. Then slide the O-ring over the threads on the shock body. Press the O-ring all the way down to the bottom of the threads.

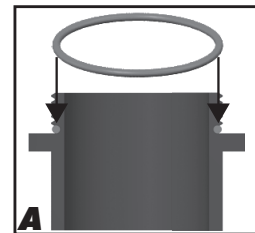

:: Shock Maintenance - (cont.)

B) Fill your shocks to the top of the sides with shock fluid. Do not over fill the shock with oil.

C) Thread the shock cap onto the shock body. These are emulsion style shocks, initially there will be air at the top of the shock.

D) You should be able to compress the shaft into the shock all the way. If you cannot, you have added too much shock fluid. Unscrew the cap 3/4 turn and tilt the shock at a slight angle. Slowly compress the shaft to push out excess oil and tighten the cap.

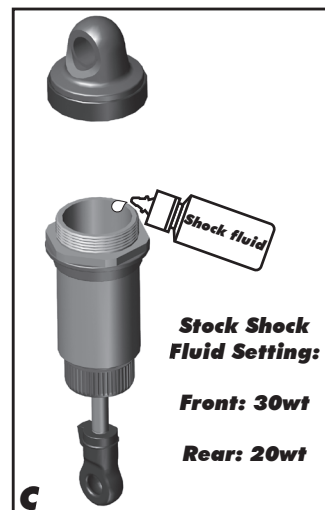
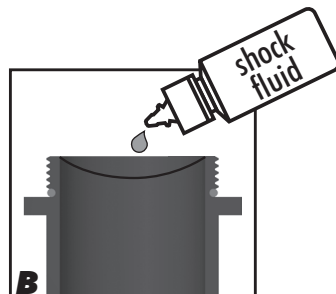

Stock Shock Fluid Setting:

Front: 30wt

Rear: 20wt



:: Motor Manual**REEDY****550-SL
BRUSHLESS
MOTOR****Introduction**

Congratulations on your purchase of the Reedy 550-SL Brushless Motor. The latest brushless motor technology along with the design and engineering experience that is responsible for 29 World Championship titles has been incorporated into its design.

Due to its sensorless design, the Reedy 550-SL Brushless Motor operates powerfully and efficiently without complicated sensor harnesses. This motor is perfectly suited for use with ESCs that are designed to operate sensorless brushless motors.

Features

- Oversized Precision Ball Bearings
- High-Torque 4-Pole Rotor
- Hardened 5mm Steel Shaft
- Triple-Insulated Windings
- Sensorless Operation
- 3.5mm Connectors
- Completely Rebuildable

Because no single motor works best in all vehicles and in all conditions, two models are available to suit any application. Be sure to visit www.reedypower.com for the latest application and gearing charts for each model and to view a complete list of spare and option parts.

Please read the following before installing and using your new motor.

Precautions and Warnings

- Please read the instructions before installing and operating your motor.
- Avoid over gearing by monitoring motor temperature. Operating temperatures should not exceed 80C (175F)
- Be sure to use the proper size motor mounting screws.
- Do not over-tighten the motor mounting screws.
- Do not use a Schottky diode with this motor.

Installation and Maintenance

- Your motor should be installed using 3mm screws with a length (generally 6mm or less) that does not allow the screw to extend into the motor more than 5mm. Otherwise, the screw can damage the motor's internal components.
- Do not over-tighten the motor mounting screws. Doing so may strip the mounting hole threads.
- Connect the three leads exiting the motor to the three motor leads from your Electronic Speed Control (ESC). If the motor runs backwards when giving it forward throttle, reverse any two motor leads. The motor will now turn in the desired direction.
- To clean your motor, lightly brush dirt away on a regular basis paying particularly close attention to the areas around the ball bearings. DO NOT spray cleaners or solvents into the motor.

Caution

When switching to a higher voltage battery from a lower one (11.1V to 7.4V, for example), a change in gear ratio or a lower kV motor might be necessary. Otherwise, the motor or ESC may overheat and sustain permanent damage. Please visit www.reedypower.com for the latest gear ratio suggestions for your particular motor and vehicle.

Safety Precautions

This product is a sophisticated hobby product and not a toy. It must be operated with caution and common sense and requires some basic mechanical ability. Failure to operate this product in a safe and responsible manner could result in injury or damage to the product or property. This product is not intended to be used by children without direct adult supervision. It is essential to read and follow all instructions and warning found in this manual prior to installation, set up, and use in order for the product to operate properly and to avoid damage or injury.

Specifications

Model	550-SL 3500kV	550-SL 4000kV
Item No.	924	925
Cells	2-3 LiPo, 4-8 NiMH	2-3 LiPo, 4-8 NiMH
RPM/Volt	3500	4000
Diameter	36mm	36mm
Length	55mm	55mm
Weight	210g/7.4oz	200g/7.1oz
Shaft Diameter	5.0mm	5.0mm
Max. Efficiency Current	10-45A	10-50A
Max. Surge Current	55A/60s	60A/60s
Internal Resistance	6.5mΩ	6.2mΩ

Warranty

Your motor is warranted to the original purchaser for 30 days from the date of purchase against defects in material and workmanship. Motors that have been mishandled, abused, used incorrectly, used for an application other than intended or damaged by the user are not covered under warranty.

Associated Electrics Inc. is not liable for any loss or damage, whether direct or indirect, incidental or consequential, or from any special situation, arising from the use, misuse, or abuse of this product.

ESC Manual



SC800-BL BRUSHLESS ESC

OWNER'S MANUAL

#29180

Congratulations on your purchase of the Reedy SC800-BL Brushless Electronic Speed Control (ESC). The latest electronics technology along with the design and engineering experience that is responsible for 29 World Championship titles has been incorporated into its design.

The Reedy SC800-BL Brushless ESC is splash-proof for maximum durability. Its light and compact design allows for easy installation in most 1/10 vehicles. When paired with Reedy brushless motors, a potent combination of power and efficiency is created resulting in quick acceleration, high top speeds, generous run times, and more fun!

Please read the following instructions before installing and operating your ESC.

FEATURES

- LiPo low-voltage cutoff protection
- LiPo cell auto-detect
- Fully proportional brakes
- Durable case with aluminum heat sink
- Pre-wired cooling fan
- Splash-proof
- Heavy duty silicone wires
- Low-resistance T-plug connector
- 3.5mm motor connectors

SPECIFICATIONS

Cells	2-3 LiPo, 6-9 NiMH
Suggested Applications	1/10 On Road, Off Road
Resistance (Ω)	0.0004 ohm
Brakes	Proportional
Motor Limit	2S LiPo, 6/7-cell NiMH 3S LiPo, 9-cell NiMH
	2-Pole 6000kV, 4-Pole 4000kV 2-Pole 3300kV, 4-Pole 3500kV
Reversible	Yes
Low Voltage Cutoff	Yes, w/Cell Auto-Detect
Dimensions (mm)	48.3 x 36.5 x 35
Weight	87.5g (3.2oz)
Power Wires	14-Gauge Silicone
Connector	Battery/T-Plug Motor/3.5mm sockets

SAFETY PRECAUTIONS

This product is a sophisticated hobby product and not a toy. It must be operated with caution and common sense and requires some basic mechanical ability. Failure to operate this product in a safe and responsible manner could result in injury or damage to the product or property. This product is not intended to be used by children without direct adult supervision. It is essential to read and follow all instructions and warnings found in this manual prior to installation, set up, and use, in order for the product to operate properly and to avoid damage or injury.

INSTALLATION

- Mount your ESC and switch securely using high quality double-sided tape.
- Install your ESC in a position that allows easy access to all connectors.
- Plug the ESC's receiver wire into the receiver (refer to radio manufacturer's manual)
- To prevent radio interference, arrange ESC wiring so that it is not in close proximity to the receiver antenna wire.
- Connect the three motor leads exiting the ESC to the three leads exiting your motor. If the motor runs backwards when giving it forward throttle, reverse any two motor leads. The motor will now run the desired direction.
- Always power ON your transmitter before the ESC and power OFF the ESC before the transmitter.

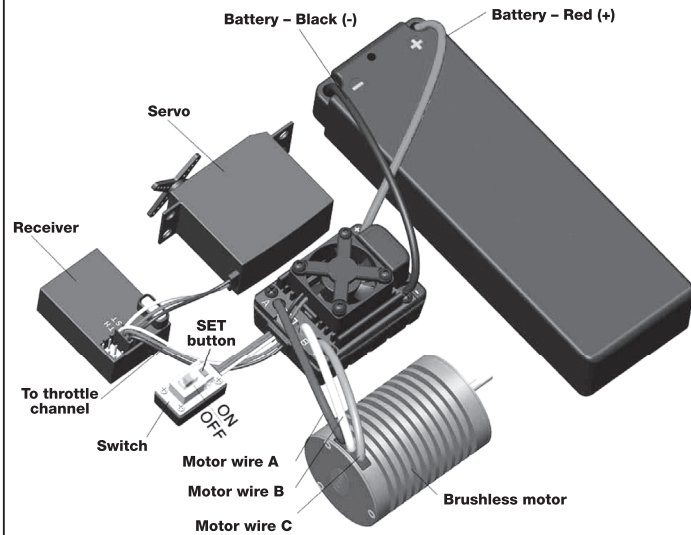

SWITCHING BETWEEN LIPO AND NIMH BATTERY MODES

A choice of either LiPo mode or NiMH mode activates the low voltage cutoff point. This is particularly important when using LiPo batteries that should not, for performance and safety reasons, be discharged below 3.2V per cell. In LiPo mode, the ESC detects whether you are using 2 or 3 cells and adjusts the cutoff accordingly. The color of the LED at neutral throttle indicates which mode the ESC is currently in. When in LiPo mode, the LED will be green. When in NiMH mode, the LED will be red. Regardless of which mode the ESC is in, the LED will always blink red when the Low Voltage Cutoff Protection is activated and flash green when the Thermal Protection is activated.

LiPo-->NiMH: With the transmitter and ESC powered ON and the throttle trigger in the neutral position, press and hold the SET button (approximately two seconds) until the green LED begins to flash. Continue to hold the SET button (approximately four more seconds) until the LED begins to flash red indicating a successful switch. Now release the SET button. The red LED will continue to flash (approximately four seconds) and then remain solid red. The ESC has successfully been switched from LiPo mode to NiMH mode and the ESC is ready to use.

NiMH-->LiPo: With the transmitter and ESC powered ON and the throttle trigger in the neutral position, press and hold the SET button (approximately two seconds) until the red LED begins to flash. Continue to hold the SET button (approximately four more seconds) until the LED begins to flash green indicating a successful switch. Now release the SET button. The green LED will continue to flash (approximately four seconds) and then remain solid green. The ESC has successfully been switched from NiMH mode to LiPo mode and the ESC is ready to use.

Note: Continuing to press the SET button after successfully switching modes will switch the mode again. Releasing the SET button after the appropriate flashing LED color confirms the mode selection.
WARNING: FAILURE TO SELECT LIPO MODE WHEN USING LIPO BATTERIES MAY RESULT IN PERMANENT DAMAGE TO THE BATTERY AND/OR FIRE.

THROTTLE CALIBRATION

Each time you install a new ESC, a new transmitter, or after changing the neutral position, ATV or EPA parameters on your radio, the throttle range must be re-calibrated. The ESC will not work properly until it has been calibrated.

There are three points that need to be set – maximum throttle, maximum brake, and the neutral point. The following steps and accompanying diagram illustrate the procedure.

Note: ESCs that came installed in an RTR vehicle have already been calibrated and are ready to use.

- Set your radio's throttle and brake EPA/ATV to 100% and your throttle trim to neutral, and then turn on your transmitter.
- Press and hold the SET button while powering ON the ESC. When the LED begins to flash, release the SET button immediately.
- With the throttle trigger at neutral, press the SET button to save the neutral position verified by one flash of the LED.
- Move the throttle trigger to the full throttle position and press the SET button to save the full throttle position verified by two flashes of the LED.
- Move the throttle trigger to the maximum brake position and press the SET button to save the maximum brake position verified by three flashes of the LED.
- Return the throttle trigger to the neutral position. After three seconds, the ESC will automatically exit the calibration procedure and the ESC is ready to use.

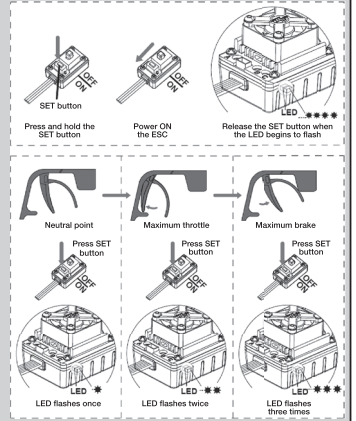

Green LED = LiPo mode
Red LED = NiMH mode

PROTECTION FUNCTIONS

LiPo Low Voltage Cutoff Protection

If the voltage of the LiPo battery falls below the minimum threshold for more than two seconds, the ESC will cut off the output power and the LED will blink red. The ESC will not operate as long as the voltage remains below 3.2V per cell (2S=6.4V, 3S=9.6V).

Note: The Low Voltage Cutoff Protection works only when the ESC is set to LiPo mode. If you fail to switch the ESC to NiMH mode when using a NiMH battery, the ESC will continue to activate when it reaches the minimum voltage threshold.

Thermal Protection

If the temperature of the ESC exceeds the maximum threshold for more than five seconds, the ESC will cut off the output power and the LED will flash green.

Throttle Signal Loss Protection

If the throttle signal is lost for more than 0.2 seconds, the ESC will cut off the output power.

ALERTS

Abnormal Input Voltage

If the input voltage is below the normal range when powered ON, the ESC will emit a "beep-beep" tone at one second intervals.

Abnormal Throttle Signal

When the ESC does not detect a normal throttle signal, the LED will flash.

WARRANTY

Your Reedy SC800-BL Brushless Electronic Speed Control is warranted to the original purchaser for 30 days from the date of purchase, verified by the sales receipt, against defects in material and workmanship. Product that has been mishandled, abused, used incorrectly, used for an application other than intended or damaged by the user is not covered under warranty. Associated Electrics Inc. is not liable for any loss or damage, whether direct or indirect, incidental or consequential, or from any special situation, arising from the use, misuse, or abuse of this product.

TROUBLESHOOTING

Problem	Cause	Solution
After powering ON the ESC, the motor does not work and no sound is emitted	The connections between battery pack and ESC are incorrect	Check the power connections
		Replace the connectors
After powering ON the ESC, the motor does not work but emits a "beep-beep" alert tone at one second intervals	Input voltage is too high or too low	Check the voltage of the battery pack
After powering ON the ESC, the motor does not work but emits a "beep-beep" alert tone at one second intervals and the red LED is illuminated	Abnormal throttle signal	Be sure the transmitter is working properly and that the batteries are charged
		Check the receiver plug connection
After powering ON the ESC, the motor does not work and the red LED blinks very quickly	The neutral point of the throttle channel has changed	Re-calibrate the throttle range of the ESC
		Adjust the throttle trim to change the neutral point
The motor runs in the opposite direction	The wire connections between the ESC and the motor need to be changed	Swap any two wire connections between the ESC and the motor
The motor suddenly stops running while driving the vehicle	The throttle signal from the transmitter has been lost	Be sure the transmitter is working properly and that the batteries are charged
	The ESC has entered Low Voltage Protection mode	Re-charge the battery/install a fully charged battery
	The ESC has entered Thermal Protection mode	Allow the ESC to cool down
Intermittent operation or random stopping/starting	Poor connections	Verify that the battery pack, receiver, and motor connections are correct
	Strong electromagnetic interference	Move to another area to operate the vehicle or wait until the interference has subsided

:: Shocks

7231	4x25mm Shock Shaft (Pro SC)	2
7232	16mm Shock Spring, White 3.0lbs	2
7233	16mm Shock Spring, Shiny Black 3.8lbs - Kit Rear	2
7234	16mm Shock Spring, Black 4.6lbs - Kit Front	2
7235	16x25mm Molded Shock Body	2
7236	16x25mm Molded Shock Kit	1
7237	16mm Shock Rod End/Ball	4ea
89066	Shock O-Ring	8
89067	Shock Limiter Set	1
89352	16mm Shock Rebuild Kit, rebuild 4 shocks	1
89353	16mm Shock Piston Kit	1
89354	16mm Shock Spring Cup	4
89394	16mm Molded Shock Caps w/ O-Rings	4ea
89396	16mm RTR Preload Clips and Spring Collar	4ea

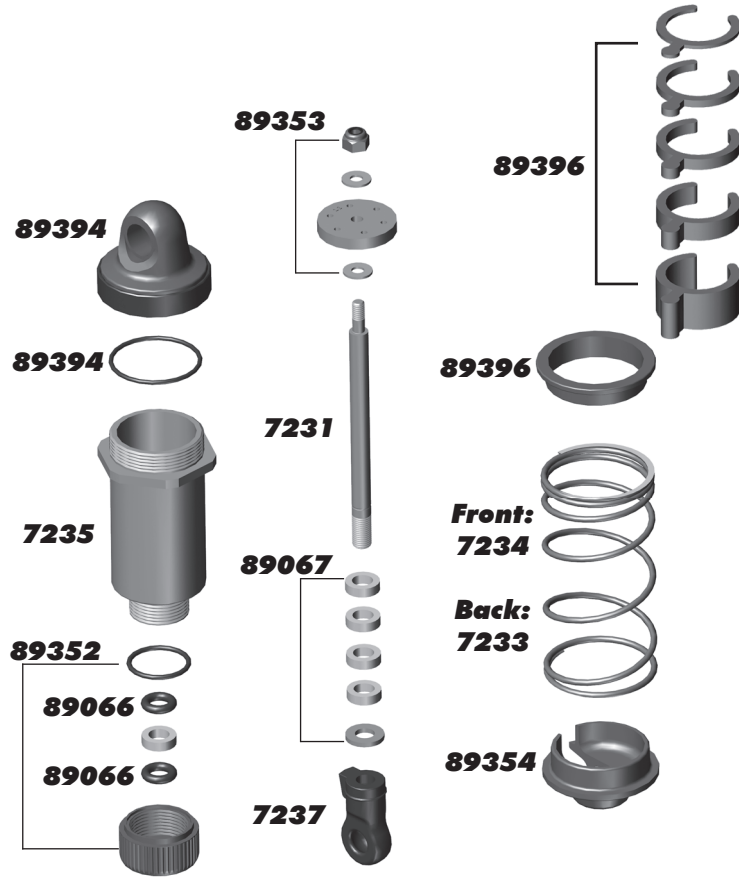

:: Shock Fluid

5420	10 Weight Silicone Shock Fluid	2oz.
5421	20 Weight Silicone Shock Fluid	2oz.
5422	30 Weight Silicone Shock Fluid	2oz.
5423	40 Weight Silicone Shock Fluid	2oz.
5424	22.5 Weight Silicone Shock Fluid	2oz.
5425	80 Weight Silicone Shock Fluid	2oz.
5426	27.5 Weight Silicone Shock Fluid	2oz.
5427	15 Weight Silicone Shock Fluid	2oz.
5428	25 Weight Silicone Shock Fluid	2oz.
5429	35 Weight Silicone Shock Fluid	2oz.
5430	45 Weight Silicone Shock Fluid	2oz.
5431	55 Weight Silicone Shock Fluid	2oz.
5432	32.5 Weight Silicone Shock Fluid	2oz.
5433	37.5 Weight Silicone Shock Fluid	2oz.
5434	42.5 Weight Silicone Shock Fluid	2oz.
5435	50 Weight Silicone Shock Fluid	2oz.
5436	60 Weight Silicone Shock Fluid	2oz.
5437	70 Weight Silicone Shock Fluid	2oz.
5438	47.5 Weight Silicone Shock Fluid	2oz.



:: Servo Saver/Mount

6338	Antenna Tube w/Cap	1
7137	Servo Mount	1
7138	Servo Saver	1
7163	Ball Stud, (3 short/7 long) Set	1
7167	Tap Screw BHPS	10
25202	M3x10mm FHCS	20

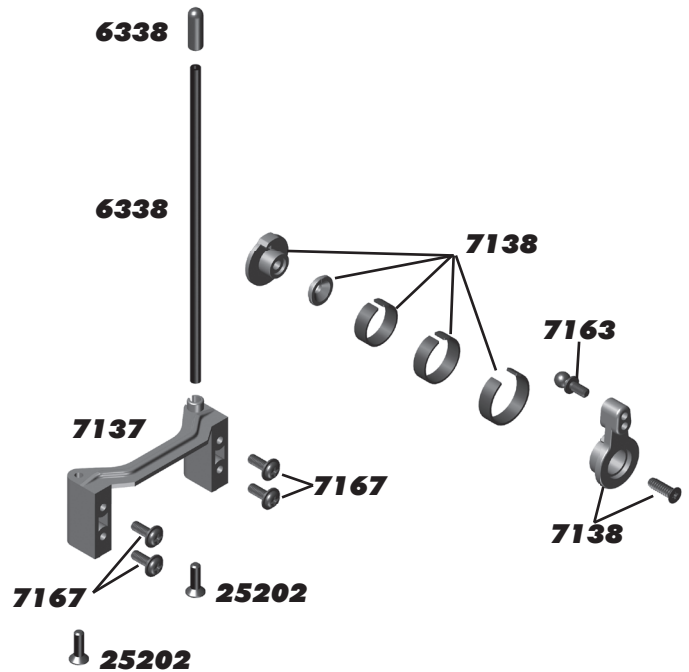

:: Steering

7139	Bellcrank Assembly, Set	1
7163	Ball Stud, (3 short/7 long) Set	1
31400	Bearing, 5x8mm	2

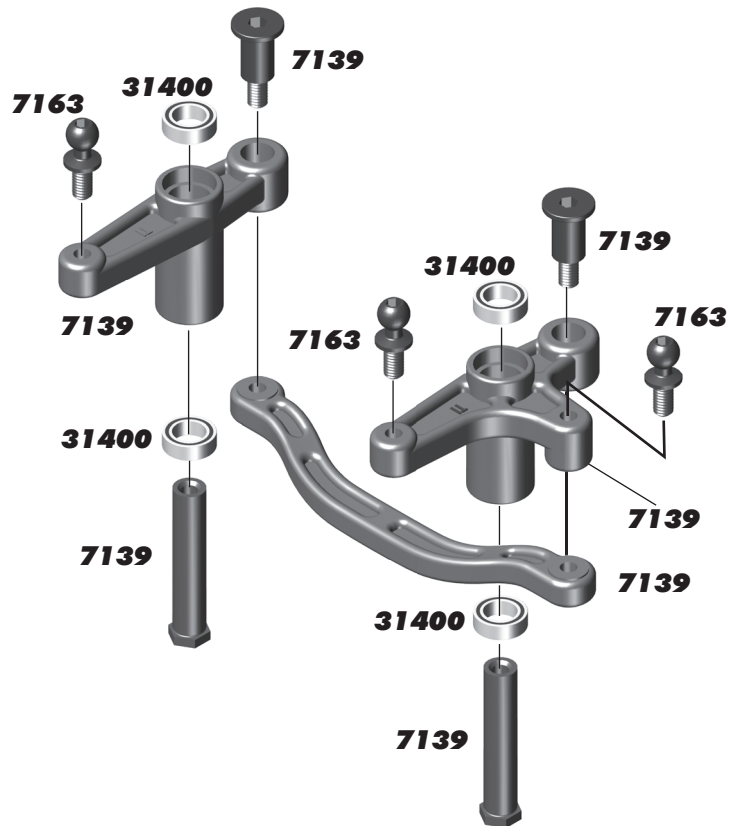

:: Front and Rear Gear Differential

7133	Diff - Complete	1
7134	Diff Outdrive w/Set Screw	2
7732	M4x4mm Set Screw	6
25607	Bearing, 8x14x4	4
31350	M2.5x10mm FHCS	6

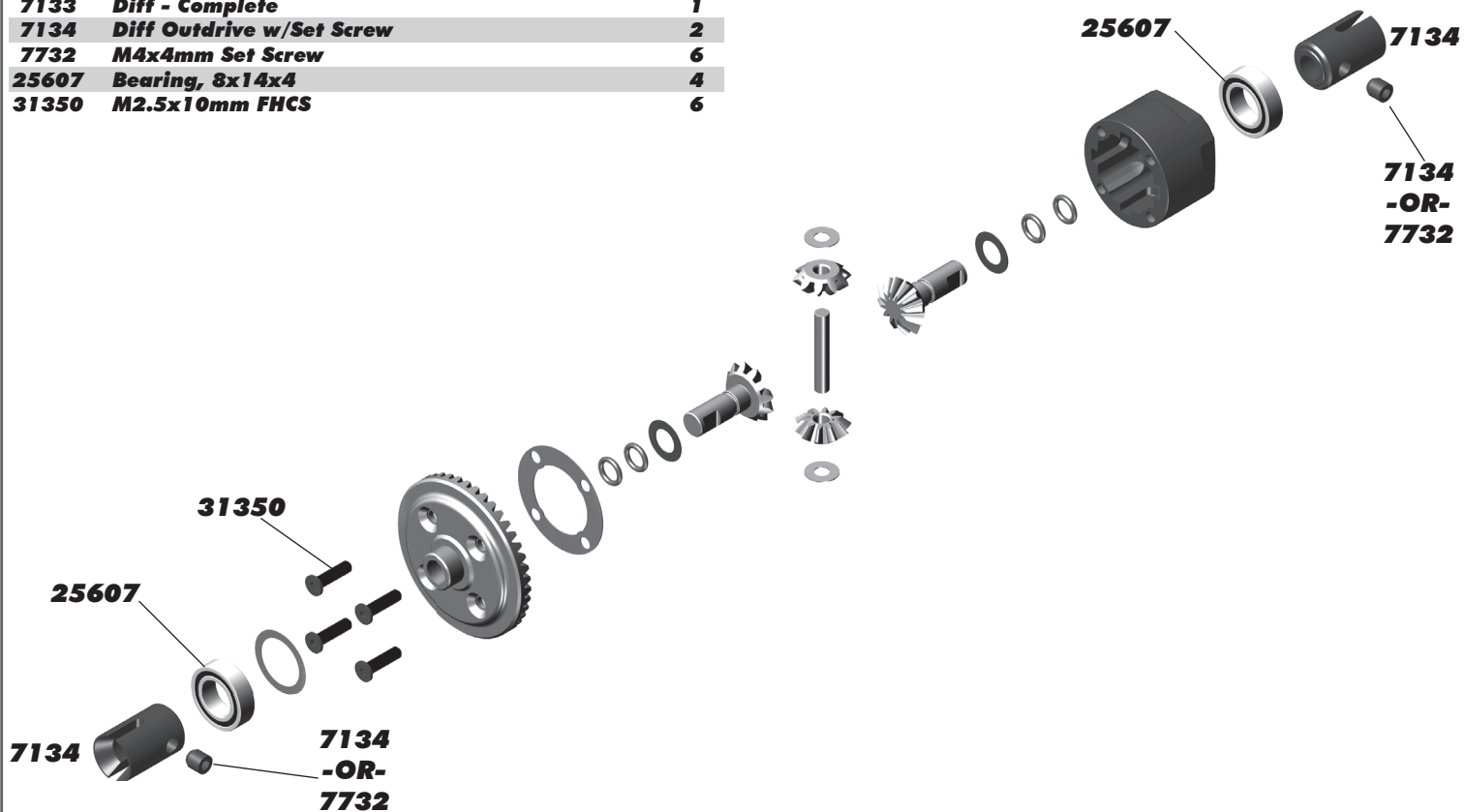

:: Lubes & Adhesives / Decals / Misc.

1105	FT Green Slime Shock Lube	1
1596	FT Locking Adhesive	1
1597	FT Tire Adhesive, Medium	1
5450	Silicone Diff Fluid 1000cst	1
5451	Silicone Diff Fluid 2000cst	1
5452	Silicone Diff Fluid 3000cst	1
5453	Silicone Diff Fluid 5000cst	1
5454	Silicone Diff Fluid 7000cst	1
5455	Silicone Diff Fluid 10000cst	1
5456	Silicone Diff Fluid 20000cst	1
5457	Silicone Diff Fluid 30000cst	1
5458	Silicone Diff Fluid 60000cst	1
5459	Silicone Diff Fluid 100000cst	1
6588	Black Grease - 4cc	1
6591	S.Diff Lube - 4cc	1
6636	Silicone Grease - 4cc	1
6727	Servo Tape	2
716	Reedy 2009 Sticker Set	1
717	Reedy Powered Logo Decal	1
3816	American Bumper Sticker	1
3820	AE Logo Decal Sheet	1
3834	AE Blue Embossed Logo Sticker	2



1596

:: Battery Strap

6332	Body Clips	6
7115	Battery Strap w/Wall & Post, Set	1
89209	M3x18mm FHCS	10
89455	M3x22mm FHCS	10

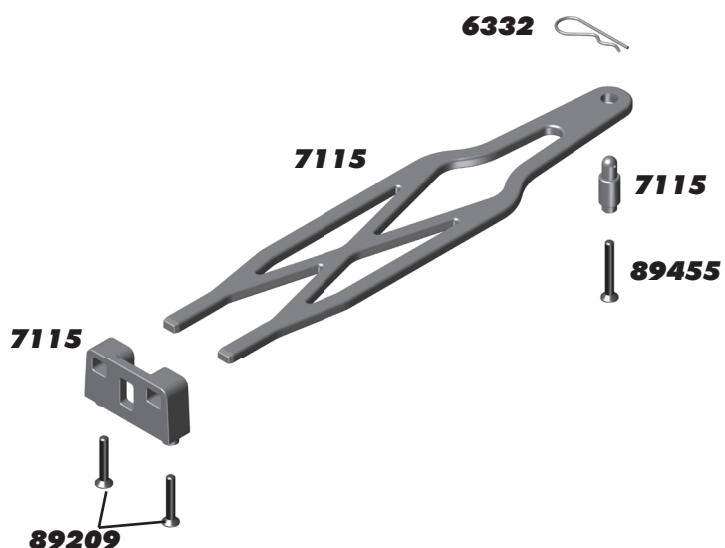

:: Front Gearbox

2308	M3x18mm BHCS	6
5407	Red Silicone O-Ring	8
7116	ProLite Chassis Braces	1
7117	Gearboxes FR/RR, Top & Bottom	1ea
7124	Front Input Shaft, Set	1
7134	Diff Outdrive, w/ set screw	2
7135	Drive Pinion	1
7155	Arm Mounts, A & D Plates	1ea
7158	Hinge Pins (inner & outer), Bushings (0, 1, 2, & arm washers) Set	1
7163	Ball Stud, (3 short/7 long) Set	1
7166	4mm E-Clip	10
7732	M4x4mm Set Screw	6
25202	M3x10mm FHCS	20
25211	M3x10mm BHCS	20
25215	M3 Locknut, black	20
25231	E-Clip, 2.5mm	20
25710	Bearing, 5 x 11 x 4	2
89202	M3x12mm BHCS	10

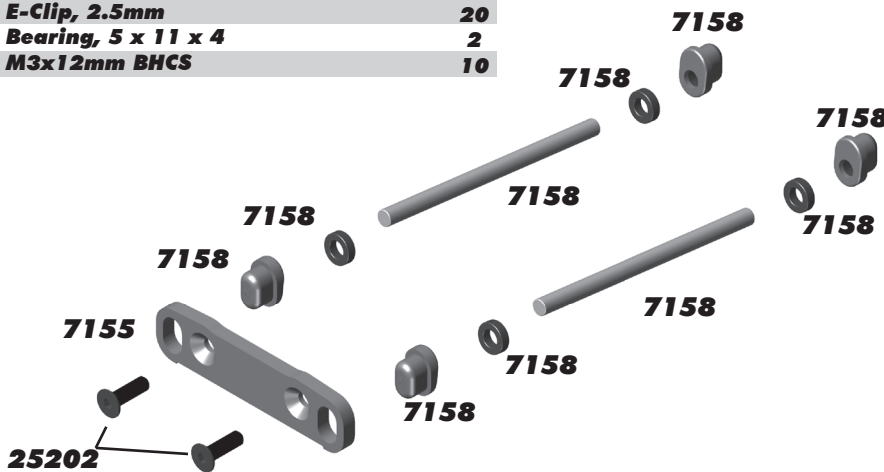
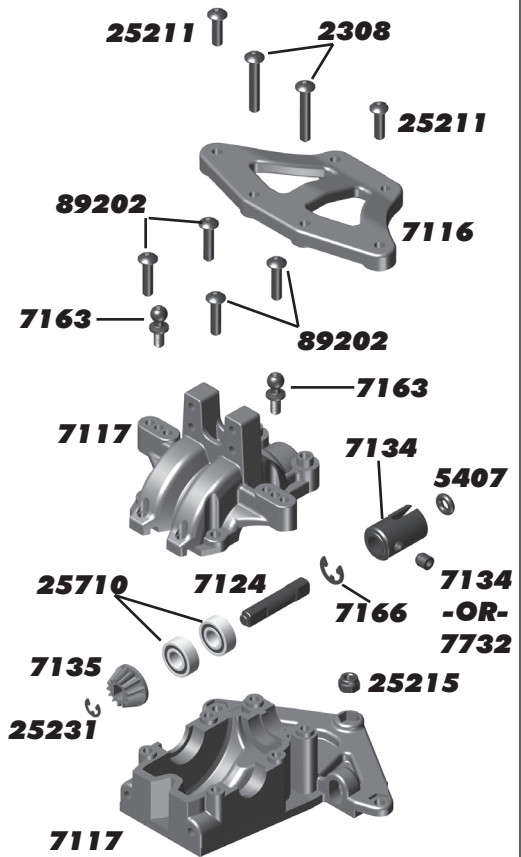
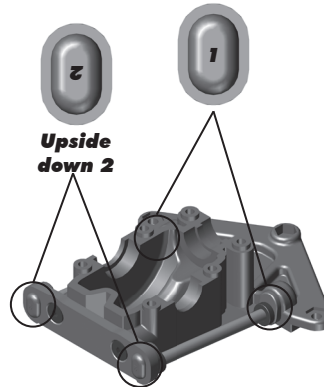

:: Front Suspension

7128	CVA Axle, Front	2
7129	CVA Bone, Front	2
7130	CVA Coupler w/Pin	2
7140	Steering & Caster Blocks	2ea
7141	Steering Block Bushing	4
7157	Front Arms w/arm washers (4) & M2x4mm BHPS screws (2), Set	1
7158	Hinge Pins (inner & outer), Bushings (0, 1, 2, & arm washers) Set	1
7163	Ball Stud, (3 short/7 long) Set	1
7165	Washer, 6x12mm	10
7168	M2x4mm BHPS, Flanged	10
7237	16mm Suspension Ball	4
7240	6x3x2mm Steel Washer	6
25211	M3x10mm BHCS	20
25616	Bearing, 10x15x4	2
89203	M3x16mm BHCS	10
91027	4x4 Wheel Hex w/Hardware	4
91148	M4 Locknut, w/Flange & Knurl	8

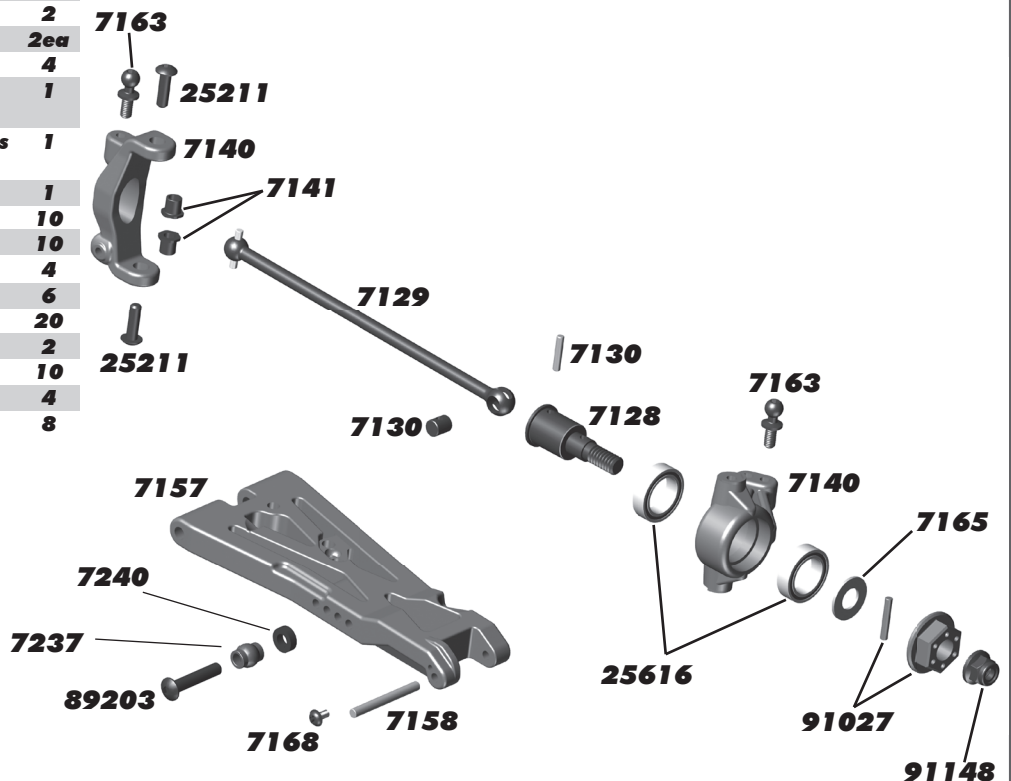

:: Rear Gearbox

7117	Gearboxes FR/RR, Top & Bottom	1ea
7155	Arm Mounts, A & D Plates	1ea
7158	Hinge Pins (inner & outer), Bushings (0, 1, 2, & arm washers) Set	1
7163	Ball Stud, (3 short/7 long) Set	1
25202	M3x10mm FHCS	20
25215	M3 Locknut, black	20
89202	M3x12mm BHCS	10

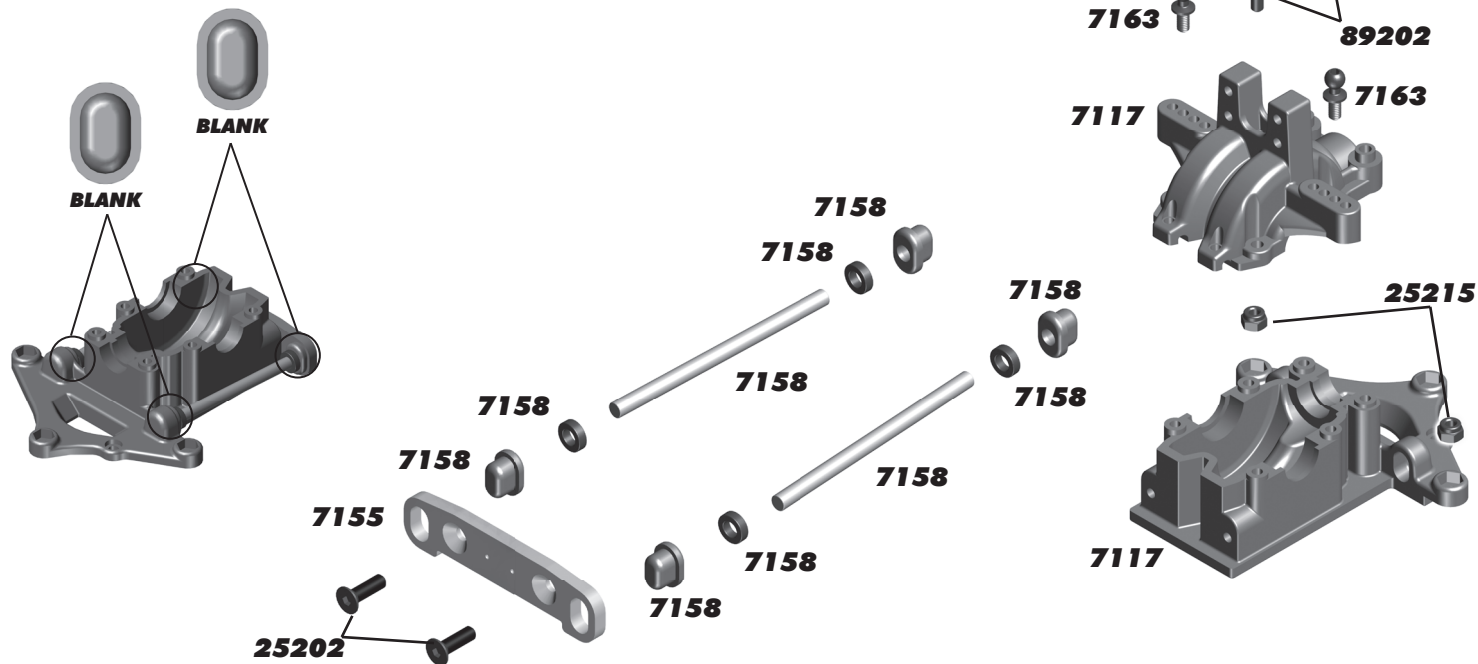

:: Rear Suspension

7131	Dogbone (RR)	2
7132	Axle/Dogbone	2ea
7142	Hub Carrier	2
7156	Rear Arms w/arm washers (4) & M2x4mm BHPS screws (2), Set	1
7163	Ball Stud, (3 short/7 long) Set	1
7158	Hinge Pins (inner & outer), Bushings (0, 1, 2, & arm washers) Set	1
7165	Washer, 6x12mm	10
7168	M2x4mm BHPS, Flanged	10
7237	16mm Suspension Ball	4
7240	6x3x2mm Steel Washer	6
25616	Bearing, 10x15x4	2
89203	M3x16mm BHCS	10
91027	4x4 Wheel Hex w/Hardware	4
91148	M4 Locknut, w/Flange & Knurl	8

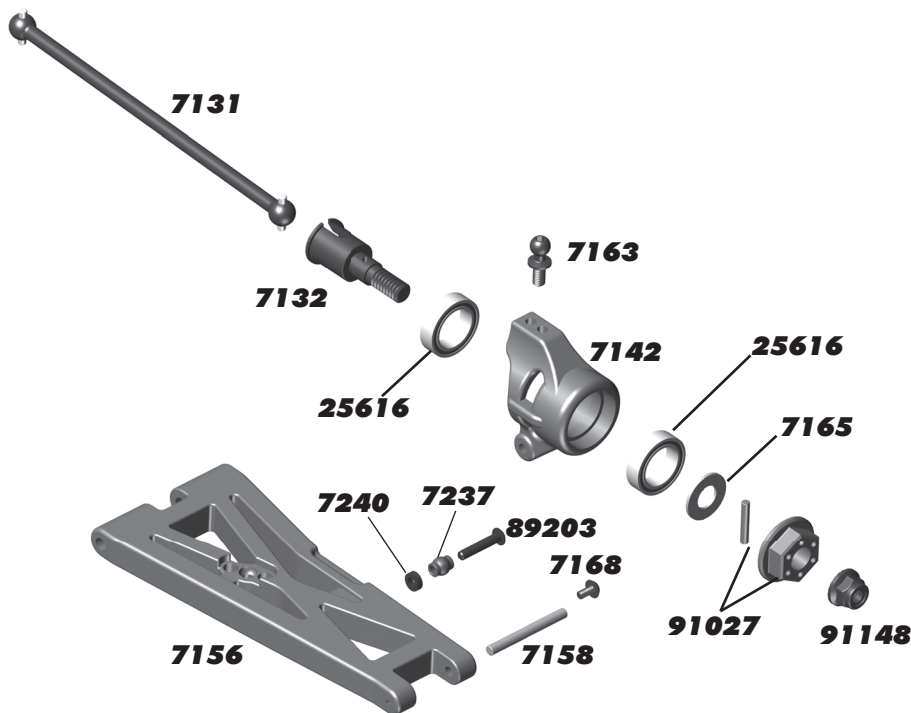

:: Front Bumper

2308	M3x18mm BHCS	6
7119	Front Bumper, Set	1
25201	M3x8mm FHCS	20
25204	M3x16mm FHCS	20
25211	M3x10mm BHCS	20

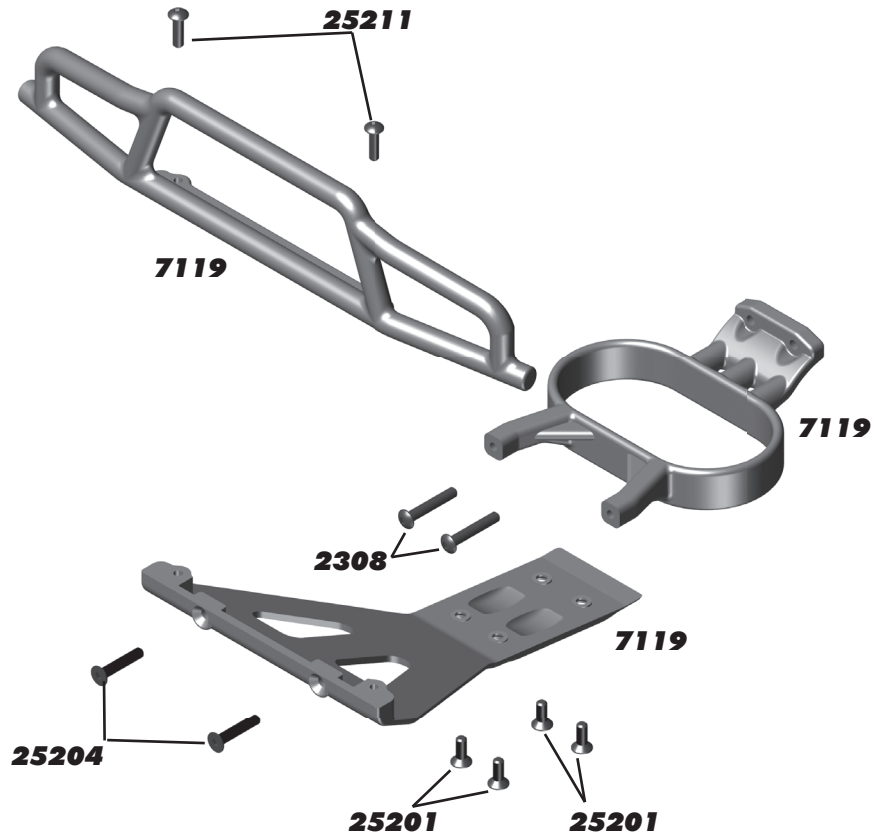

:: Rear Bumper

2308	M3x18mm BHCS	6
7120	Rear Bumper, Set	1
7121	ProLite Mud Flaps	2
25201	M3x8mm FHCS	20
25187	M3x14mm BHCS	20
89203	M3x16mm BHCS	10
89218	Washer, 3x8mm	10

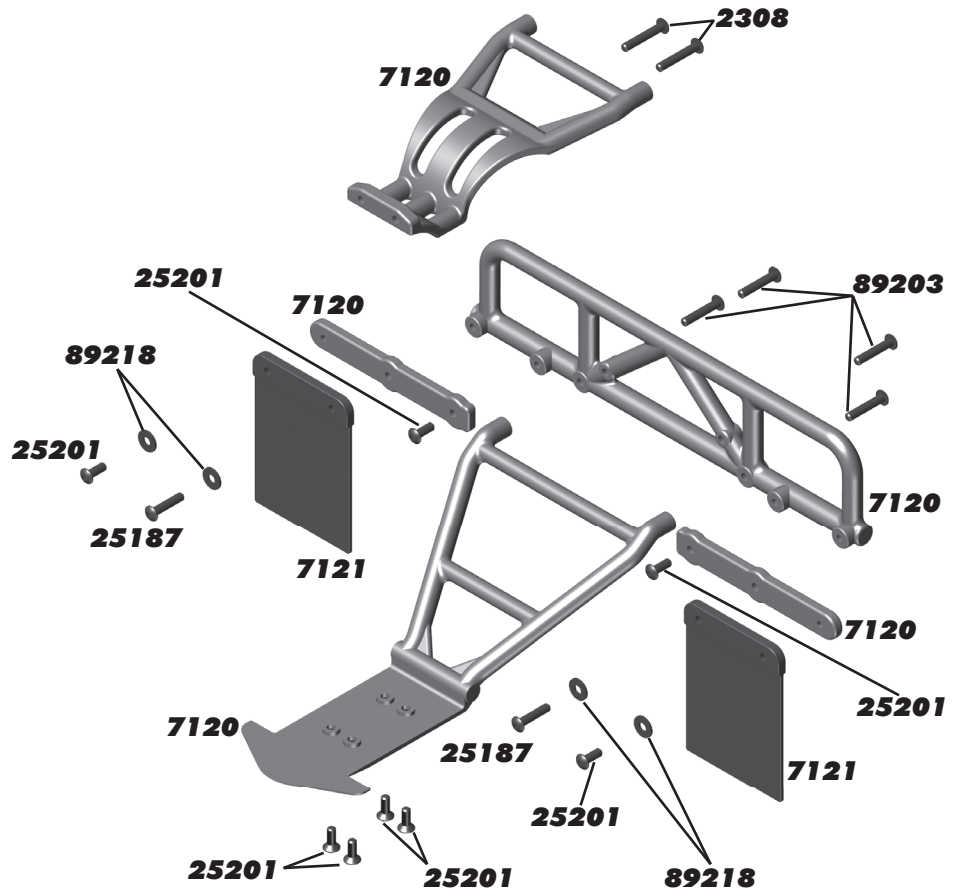

:: Front Shock Tower

7154	Shock Tower, Front & Rear	1ea
7173	Pro Rally Body Mount Set	1
7184	M2x16mm SHCS	10
25187	M3x14mm BHCS	20
25612	M3 Locknut with Flange, black	20
89083	Shock Bushing	4
89218	Washer, 3x8mm	10
89473	Shock Standoff, steel	2
91478	M3x30mm BHCS	6

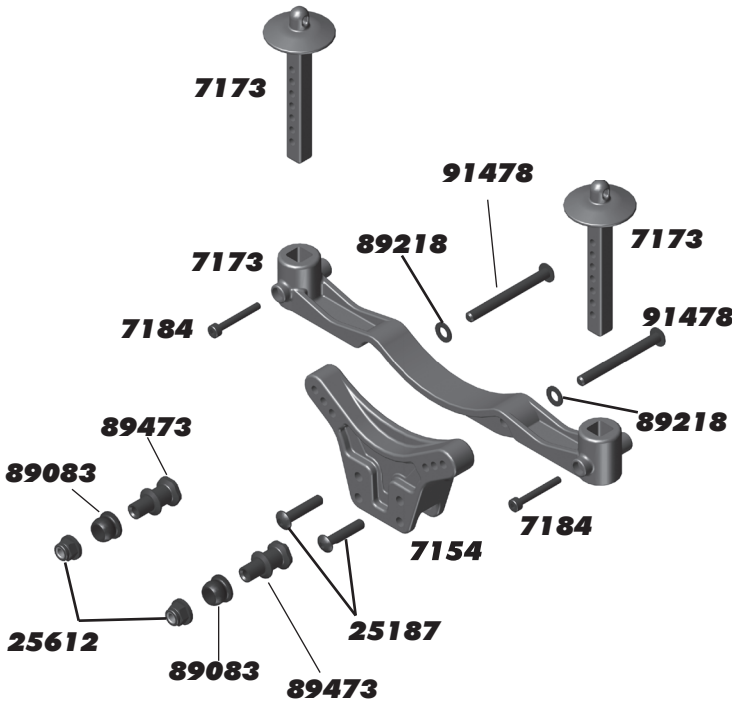

:: Rear Shock Tower

7154	Shock Tower, Front & Rear	1ea
7173	Pro Rally Body Mount Set	1
7184	M2x16mm SHCS	10
25187	M3x14mm BHCS	20
25612	M3 Locknut with Flange, black	20
89083	Shock Bushing	4
89218	Washer, 3x8mm	10
89473	Shock Standoff, steel	2
91478	M3x30mm BHCS	6

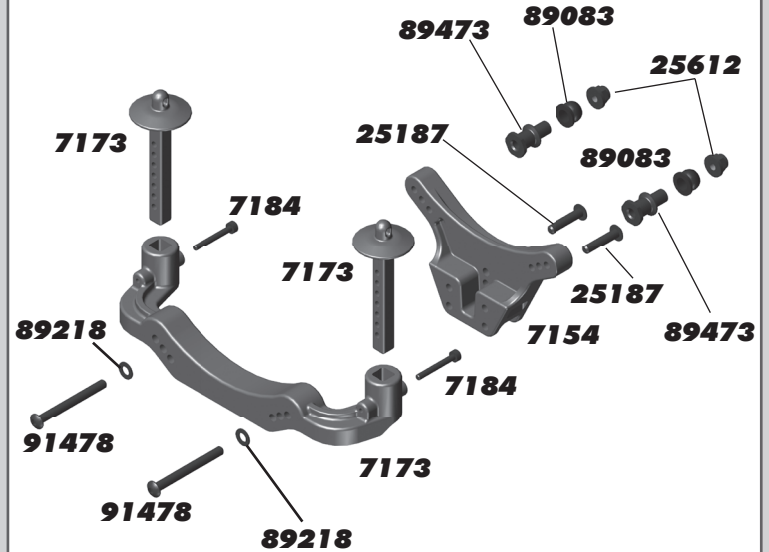

:: Motor Mount

4675	M2.5x6mm FHCS	6
7136	Motor Mount Set	1
7164	Washer, 3x6x0.5mm	10
25202	M3x10mm FHCS	20
25620	M3x10mm SHCS	20
91158	M3x4mm BHCS	10

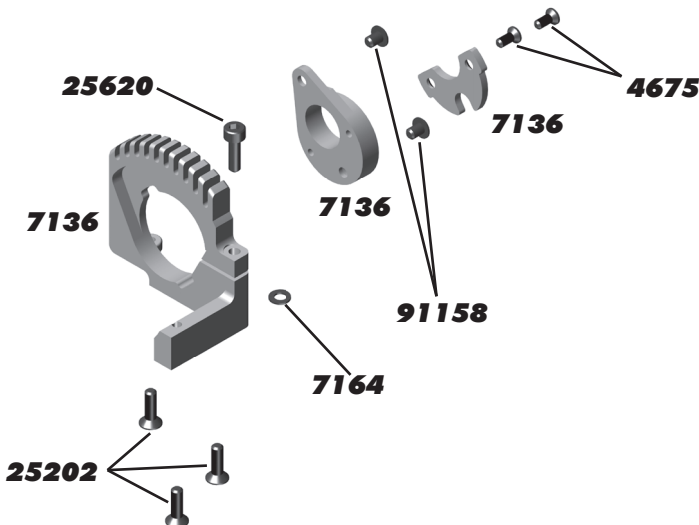

:: Turnbuckles

7159	ProLite Turnbuckle Set w/ Ball Cups	1
7160	ProLite Ball Cups	14

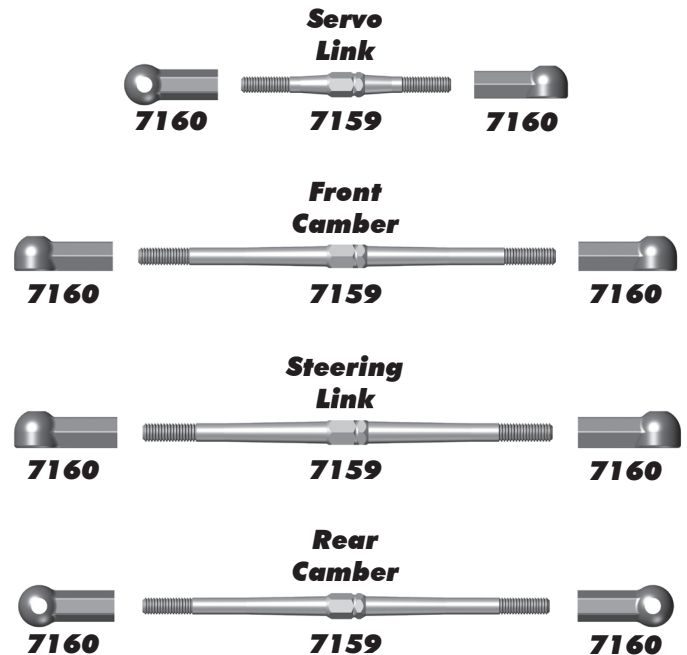

:: Chassis

2308	M3x18mm BHCS	6
7112	ProLife Chassis	1
7113	Nerf Bars	2
7114	Receiver Box w/Gaskets	1
7116	ProLife Chassis Braces	1
25187	M3x14mm BHCS	20
25202	M3x10mm FHCS	20
25211	M3x10mm BHCS	20
25215	M3 Locknut, black	20
31532	M3x8mm BHCS	6
89202	M3x12mm BHCS	10
89203	M3x16mm BHCS	10

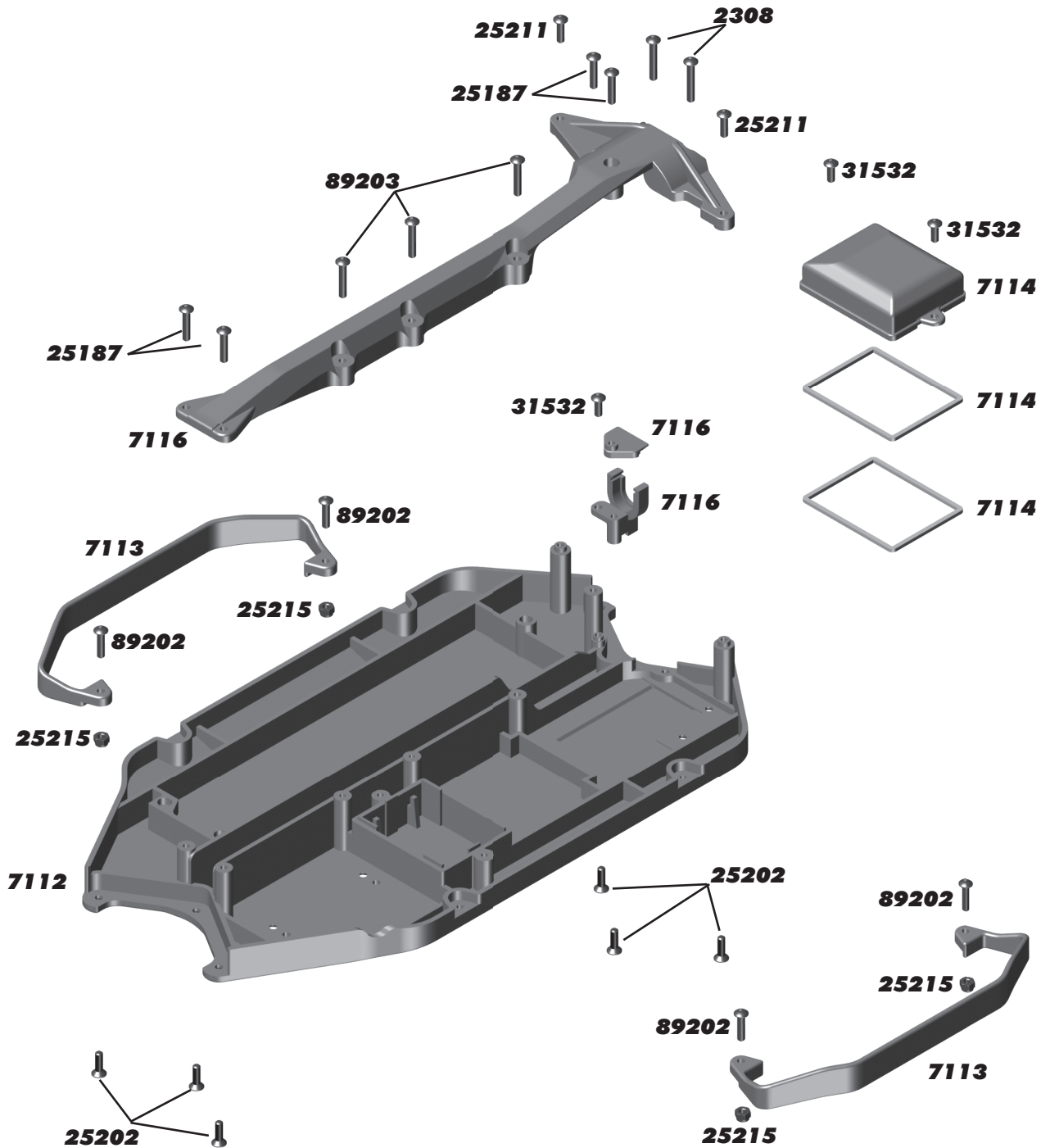

:: Slipper, Spur Gear, Pinion, and Drive Shaft

5407	Red Silicone O-Ring	8
7122	Spur Gear 32P, 47T	1
7123	Slipper Hardware, Kit	1
7124	Slipper Shaft	1
7125	Slipper Pads	2
7126	Slipper Hubs	2
7127	Drive Shaft w/ O-Rings	1
7135	Drive Pinion	1
7732	M4x4mm Set Screw	6
25225	M3x3mm Set Screw	20
25231	E-Clip, 2.5mm	20
25710	Bearing, 5x11x4	2
91162	Pinion Gear, 11T 32P (5mm shaft)	1
91163	Pinion Gear, 12T 32P (5mm shaft)	1
91164	Pinion Gear, 13T 32P (5mm shaft)	1
91165	Pinion Gear, 14T 32P (5mm shaft) Kit	1
91166	Pinion Gear, 15T 32P (5mm shaft)	1

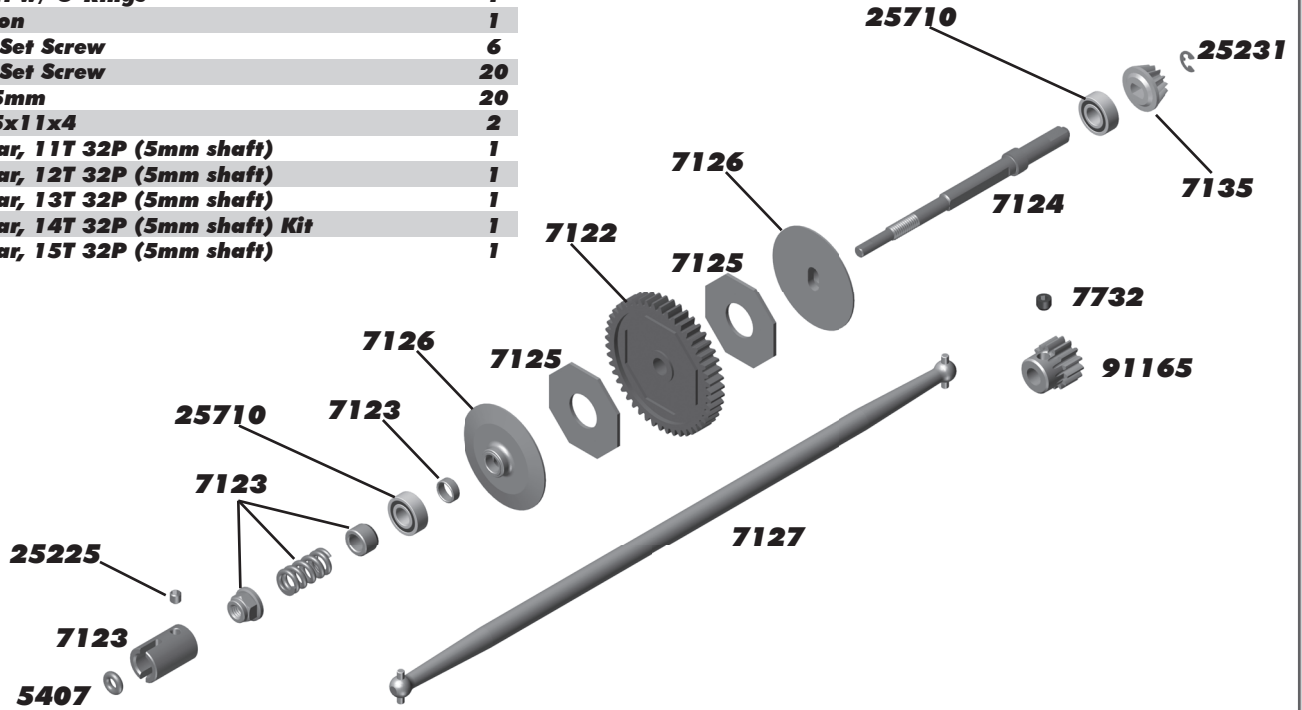

:: Wheels / Tires

7174	Pro Rally Wheel, Black	2
7175	Pro Rally Wheel, White	2
7176	Pro Rally Tire	2
7177	Pro Rally Wheel and Tire, Black - Kit	2
7178	Pro Rally Wheel and Tire, White	2
7242	Pro SC Wheel/Race Tire	2
9809	SC10 Tire, With Foam Insert - Kit	2
9921	SC10 SC10 Hex Wheel/Race Tire	2
9922	SC10RS Tires and Inserts	2
89413	Molded Tire Insert	2
91101	KMC Hex Wheels, Black	2
91102	KMC Hex Wheels, Silver	2
91103	KMC Hex Wheels, Chrome	2
91104	KMC Hex Wheels/Tire Mounted Black	2
91105	KMC Hex Wheels/Tire Mounted Silver	2
91106	KMC Hex Wheels/Tire Mounted Chrome	2

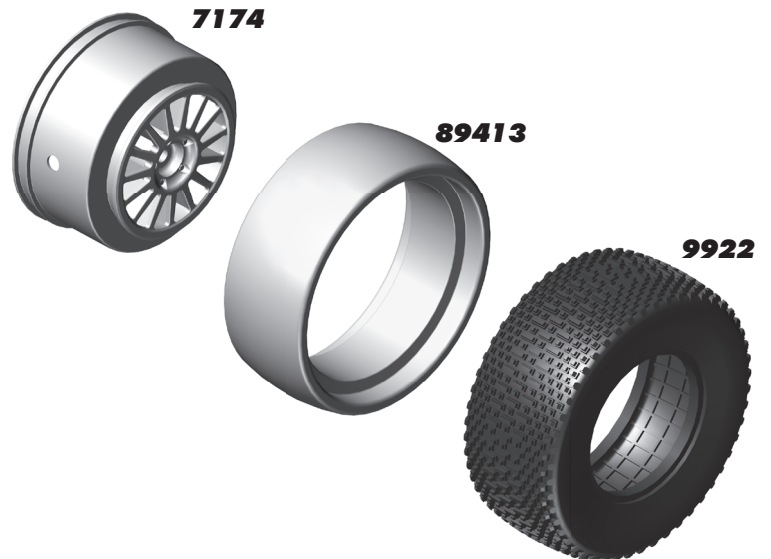

:: Body / Decals

1734	FT Body Clips, Metallic Blue, 4 long, 6 short	1
1735	FT Body Clips, Metallic Blue, long	4
1736	FT Body Clips, Metallic Blue, short	6
1737	FT Body Scissors	1
6332	Body Clips	6
7161	ProLite Body, Gray painted	1
7162	ProLite Body, Blue painted	1
7169	ProLite Decal Sheet	1
7238	Pro SC Body, Blue/Yellow	1
7239	Pro SC Body, Blue/White	1
9836	SC10 Body, clear	1
9837	SC10 09' Championship Body, clear	1
9838	SC10 KMC™ Body, painted	1
9842	SC10 AE Body, painted	1
9843	SC10 Decal Sheet, KMC™	1
9844	SC10 Decal Sheet, Lucas Oil	1
9846	SC10 Decal Sheet, Pro Comp	1
9848	SC10 ReadyLift Body, painted	1
9849	SC10 Decal Sheet, ReadyLift	1
9850	SC10 Number Plate Decals	1
9856	SC10 09' Lucas Oil Body, painted	1
9857	SC10 09' Decals, Lucas Oil	1
9858	SC10 09' Pro Comp Body, painted	1
9860	SC10 09' Speed Technologies Body, painted	1
9862	SC10 09' Rockstar-Makita Body, painted	1
9863	SC10 09' Decals, Rockstar-Makita	1
9876	SC10 Contender Body, clear	1
9886	SC10 09' Slick Mist Body, painted	1
9896	SC10 09' Hart and Huntington Body, painted	1
9897	09' Hart and Huntington Decal Sheet	1

:: Reedy Accessories

247	Sonic 540 Mach 2 Sensor w/bearing	1
248	Sonic 540 Mach 2 Steel Bearing Set	1
249	Sonic 540 Mach 2 Ceramic Bearing Set	1
250	Sonic 540 Mach 2 Insulator Set	1
606	Charge Harness 2S Saddle Pack 4mm	1
607	Charge Harness 2S Standard Pack 4mm	1
609	TAM to DEANS® charge adapter	1
647	Silicone Wire 12AWG-Black (1m)	1
648	Silicone Wire 14AWG-Black (1m)	1
649	Silicone Wire 16AWG-Black (1m)	1
650	Shrink Tubing - 15pcs 4.5mm x 20mm	1
654	4.0mm plugs (2M, 2F)	1
655	4.0mm plugs (10F)	1
656	4.0mm plugs (10F)	1
658	4.0mm plugs (10M)	1
659	4.0mm plugs (30M)	1
660	3.5mm plugs (3M, 3F)	1
661	3.5mm plugs (10F)	1
663	3.5mm plugs (10M)	1
664	3.5mm plugs (30M)	1
716	Reedy 09 Decal Set	1
962	Sonic 540 Case Screws (3 pcs.)	1
974	540-SL/550-SL Steel Bearing Set	1
975	540-SL/550-SL Ceramic Bearing Set	1
978	Flat Sensor Wire 70mm	1
979	Flat Sensor Wire 110mm	1
980	Flat Sensor Wire 150mm	1
981	Flat Sensor Wire 200mm	1
982	Flat Sensor Wire 270mm	1
992	Sonic 540 Rotor Spacers	1

:: Factory Team and Option Parts

1734	FT Body Clips, Metallic Blue, 4 Long, 6 Short	1
1735	FT Body Clips, Metallic Blue, Long	4
1736	FT Body Clips, Metallic Blue, Short	6
1737	FT Body Scissors	1
7183	Sway Bar Set - Pro lite / Pro Rally	1
9787	FT Chassis Protective Sheet	1
31286	FT Ballstud Washer, Aluminum (2mm and 1mm)	4ea
31550	FT M3 Locknut, Blue Aluminum	6
89082	RC8 SHock Standoffs, Aluminum	4
91160	Body Clip, 1.3mm Thick	10
91171	4x4 Aluminum Wheel Hexes	4

:: Reedy Batteries

302	AA Alkaline 1.5V (4)	1
724	Wolfpack 3000mAh 8.4V w/T-Plug connector	1
725	Wolfpack 3600mAh 8.4V w/T-Plug connector	1
751	Wolfpack LiPo 3300mAh 7.4V 30C w/T-Plug	1
752	Wolfpack LiPo 4000mAh 7.4V 35C w/T-Plug	1
753	Wolfpack LiPo 5400mAh 7.4V 35C w/T-Plug	1
754	Wolfpack LiPo 7500mAh 7.4V 30C w/T-Plug	1
755	Wolfpack LiPo 3300mAh 11.1V 35C w/T-Plug	1

:: XP Electronics

29107	XP DS1903/S1903 Metal Gear Set	1
29133	XP DS1903 Digital Servo	1
29134	XP DS1903MG Digital Servo	1
29166	XP DS1313 Digital Servo	1
29167	XP DS1015 Digital Servo	1
29168	XP DS1510MG Digital Servo	1
29209	Gear Set, DS1313	1
29210	Gear Set, DS1015	1
29211	Servo Case, DS1313/DS1015	1
29212	Accessory Pack, DS1313/DS1015	1
29214	TRS403-SSI 2.4GHz 4Ch Receiver	1
29215	XP2G 2.4GHz Radio System	1

:: Reedy Servos

27100	RS1206 Digital HV Hi-Speed Competiton Servo	1
27101	RT1508 Digital HV Hi-Speed Competiton Servo	1

:: Reedy Motors and ESC's

231	Sonic 540 Mach 2 21.5 Competition Brushless Motor	1
232	Sonic 540 Mach 2 17.5 Competition Brushless Motor	1
233	Sonic 540 Mach 2 13.5 Competition Brushless Motor	1
234	Sonic 540 Mach 2 10.5 Competition Brushless Motor	1
235	Sonic 540 Mach 2 9.5 Competition Brushless Motor	1
236	Sonic 540 Mach 2 8.5 Competition Brushless Motor	1
237	Sonic 540 Mach 2 8.0 Competition Brushless Motor	1
238	Sonic 540 Mach 2 7.5 Competition Brushless Motor	1
239	Sonic 540 Mach 2 7.0 Competition Brushless Motor	1
240	Sonic 540 Mach 2 6.5 Competition Brushless Motor	1
241	Sonic 540 Mach 2 6.0 Competition Brushless Motor	1
242	Sonic 540 Mach 2 5.5 Competition Brushless Motor	1
243	Sonic 540 Mach 2 5.0 Competition Brushless Motor	1
244	Sonic 540 Mach 2 4.5 Competition Brushless Motor	1
245	Sonic 540 Mach 2 4.0 Competition Brushless Motor	1
246	Sonic 540 Mach 2 3.5 Competition Brushless Motor	1
908	Replacement Rotor 540-SL	1
909	Replacement Rotor 550-SL	1
920	540-SL Brushless Motor 3300kV	1
921	540-SL Brushless Motor 3900kV	1
922	540-SL Brushless Motor 4900kV	1
923	540-SL Brushless Motor 6100kV	1
924	550-SL Brushless Motor 3500kV	1
925	550-SL Brushless Motor 4000kV	1
954	Sonic 540 Stock Rotor 12.3 x 24.2 (7.25)	1
956	Sonic 540 Stock Rotor 12.5 x 25.0 (7.25)	1
958	Sonic 540 Modified Rotor 12.5 x 25.0 (5.0)	1
965	Reedy 540-SL 3300kV/XP SC700-BL ESC Combo	1
966	Reedy 540-SL 3900kV/XP SC700-BL ESC Combo	1
967	Reedy 540-SL 4900kV/XP SC700-BL ESC Combo	1
983	Reedy 540-SL 3300kV/XP SC1200-BL ESC Combo	1
984	Reedy 540-SL 3900kV/XP SC1200-BL ESC Combo	1
985	Reedy 540-SL 4900kV/XP SC1200-BL ESC Combo	1
986	Reedy 540-SL 6100kV/XP SC1200-BL ESC Combo	1
987	Sonic 540 Modified Rotor 13.0 x 25.0 (5.0)	1
29180	SC900-BL Brushless RTR ESC	1

:: 1/18 Kits and RTR's

20103	RC18B2 - RC18T2 Team Kit	1
20121	SC18 RTR Brushless (ready-to-run)	1

:: 1/12, 1/10 Kits and RTR's

4020	FT 12R5.2 Kit	1
7025	FT RC10T4.2 Kit	1
7030	SC10 KMC Wheels Race Truck RTR (ready-to-run)	1
7038	FT SC10.2 Kit	1
7039	RC10T4.2 RS RTR 2.4GHz Brushless (ready-to-run)	1
7046	SC10 RS RTR, Lucas Oil (ready-to-run)	1
7049	SC10 RS RTR, Rockstar/Makita (ready-to-run)	1
7093	SC10GT RTR (ready-to-run)	1
9042	RC10B4.2 RS RTR 2.4GHz Brushless (ready-to-run)	1
9050	SC10B RS RTR (ready-to-run)	1
9063	FT B44.3 4WD Buggy Kit	1
30101	TC4 Club Racer 4WD Touring Car Race Roller	1
30109	FT TC6.2 Kit	1
90001	RC10B5 Team Kit	1
90003	RC10B5M Team Kit	1

:: Qualifier Series Vehicles

7062	Pro SC 4x4 RTR, 1/10 Scale (ready-to-run)	1
7070	Pro Rally 4wd RTR, 1/10 Scale (ready-to-run)	1
20111	Rival Mini Monster Truck 1/18 Scale (ready-to-run)	1
20119	APEX Mini Touring RTR	1
20510	RIVAL Electric Monster Truck RTR, 1/8 Scale (ready-to-run)	1
30112	APEX Touring V-Type, 1/10 Scale (ready-to-run)	1

:: 1/8 Kits and RTR's



20501	MGT 4.60 SE RTR (ready-to-run)	1
20502	MGT 8.0 Nitro RTR (ready-to-run)	1
20503	Limited Edition MGT 4.60 Nitro RTR, w/flag body (ready-to-run)	1
20504	Limited Edition MGT 8.0 Nitro RTR, w/flag body (ready-to-run)	1
80907	RC8.2e Electric Buggy FT Kit	1
80908	RC8.2e Electric Buggy RTR (ready-to-run)	1
80909	RC8.2RS Nitro Buggy RTR (ready-to-run)	1
80912	RC8T Championship Edition	1

:: Hardware - 1:1 Scale View

Cap Head (shcs)

 **3x10mm (25620)**







Set screw

 **3x3mm (25225)**
 **4x3mm (25223)**
 **4x4mm (7732)**







Nuts (lock/plain)

 **M3 Locknut (25215)**
M3 Alum. Locknut, Blue (31550)
 **M4 Locknut w/Flange & Knurl (91148)**
FT M4 Locknuts w/Flange, Blue (31551)



Shims and Washers

 **Nylon Spacer .030 (4187)**
 **Arm Shim (7158)**
 **3x6mm Washer (7164)**
 **3x8mm Thin Washer (89218)**
 **6x12mm Washer (7165)**
 **Pro Lite Diff Shim (7133)**







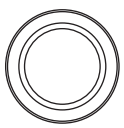

Flat Head (fhcs)

 **2.5x6mm (4675)**
 **2.5x10mm (31350)**
 **3x8mm (25201)**
 **3x10mm (25202)**
 **3x16mm (89224)**
 **3x18mm (89209)**
 **3x22mm (89455)**

Ball Bearings

 **5x8mm (31400)**
 **5x11x4mm, qty 2 (25710)**
qty 4 (25618)
 **10x15x4mm (25616)**

Button Head (bhcs)

 **2.5x6mm (31520)**
 **3x4mm(91158)**
 **3x8mm (31532)**
 **3x10mm (25211)**
 **3x12mm (89202)**
 **3x14mm (25187)**
 **3x16mm (89203)**
 **3x18mm (2308)**
 **3x26mm (89205)**

Button Head (bhps)

 **2x4mm, flanged (7168)**
 **Tap Screw (7167)**

Ballstuds

 **Ballstud, short (7163)**
 **Ballstud, long (7163)**

:: Apparel

SP20	AE Patch Trucker Hat	1
SP21	AE Patch	1
SP23**	AE Splash T-shirt - Black (S, M, L, XL, 2-5XL)	1
SP24**	AE Splash T-shirt - Blue (S, M, L, XL, 2-5XL)	1
SP31**	27 Time WC T-shirt - Black (S, M, L, XL, 2XL, 3XL)	1
SP32**	AE Kids T-shirt - Blue (S, M, L)	1
SP37**	Reedy 2012 T-shirt - Black (S, M, L, XL, 2XL, 3XL)	1
SP38	Reedy Trucker Hat	1
SP39	Reedy Patch	1
SP77**	AE 2012 T-Shirt, Blue (S)	1
SP78**	AE 2012 T-Shirt, White (S, 3XL)	1
SP79**	AE 2012 T-Shirt, Black (S, XL, 2XL)	1
SP84**	Reedy 3D T-Shirt, Black (S, M, L, XL, 2XL, 3XL)	1
SP85**	Reedy Zip Hoodie, Black (S, M, L, XL, 2XL, 3XL)	1
SP86**	Reedy Girl's 3D T-Shirt, Black (S, M, L, XL)	1
SP87**	AE 2013 Zip Hoodie (S, M, L, XL, 2XL, 3XL)	1
SP90**	AE Retro T-shirt, Blue (S, M, L, XL, 2-5XL)	1
SP91**	AE Retro T-shirt, Black (S, M, L, XL, 2-5XL)	1
SP92**	AE Retro T-shirt, White (S, M, L, XL, 2-5XL)	1
SP93**	AE 2013 Worlds T-shirt - Blue (S, M, L, XL-5XL)	1
SP94**	AE 2013 Worlds T-shirt - Black (S, 3XL, 5XL)	1
SP95**	AE 2013 Worlds Hoodie - Black (S, M, L, XL-3XL)	1
SP96**	AE Womens Retro - Pink (S, M, L, XL)	1
SP420**	AE Pit Gloves (L, XL)	Pr.
SP421S	AE 2012 Hat, Black, Flat Bill, S/M	1
SP421L	AE 2012 Hat, Black, Flat Bill, L/XL	1
SP422S	AE 2012 Hat, Black, Curved Bill, S/M	1
SP422L	AE 2012 Hat, Black, Curved Bill, L/XL	1
SP423S	AE 2012 Hat, White, Flat Bill, S/M	1
SP423L	AE 2012 Hat, White, Flat Bill, L/XL	1
SP424S	AE 2012 Hat, White, Curved Bill, S/M	1
SP424L	AE 2012 Hat, White, Curved Bill, L/XL	1
715	Reedy 2009 Track Banner	1
110684	Team Associated Track Banner	1

:: RePlay Cameras

RP004	Replay XD1080 Mini Complete Camera System	1
RP005	Replay XD PrimeX Camera System	1
RP021	Replay XD1080 Lens Bezel Kit	1
RP022	Replay XD1080 Clear Lens Cover	1
RP023	Replay XD1080 Lens Bezel & Rear Cap O-Ring	1
RP029	Replay XD1080 HDMI to Mini-HDMI	1
RP030	Replay XD1080 Mini 8-pin USB Charge Data Cable	1
RP032	USB DC Car Charger 1A Stubby	1
RP034	Micro SDHC USB Reader	1
RP036	3M VHB 4991 Mount Adhesive for SnapTray	1
RP042	Replay XD Suction Cup Short Arm Base	1
RP043	Replay XD Skateboard Mount	1
RP044	Replay XD VHB SnapTray, Convex	1
RP045	Replay XD VHB SnapTray, Flat	1
RP046	Au Plug for Universal DC Wall Charger	1
RP047	Eu Plug for Universal DC Wall Charger	1
RP048	Uk Plug for Universal DC Wall Charger	1
RP049	Universal USB DC Wall Charger 1A	1
RP050	Au Plug for Uni DC Wall Charger	1
RP054	Replay ReView Field Monitor	1
RP055	Replay PrimeX Lens 5 pack	1
RP056	Replay PrimeX HDMI Cable	1
RP057	Replay PrimeX Deep Dive Waterproof Case	1
RP058	Replay PrimeX Heim Lock Mount	1
RP059	Replay PrimeX Low Boy Mount	1
RP060	Replay PrimeX Tilt Mount	1

:: Tools

1111	FT Turnbuckle Wrench	1
1112	FT 4mm Turnbuckle Wrench	1
1449	FT Off Road Ride Height Gauge	1
1541	FT Hex Driver Set, (7 pcs)	1
1542	FT .050" Silver Hex Driver	1
1543	FT 1/16" Black Hex Driver	1
1544	FT 1.5mm Purple Hex Driver	1
1545	FT 5/64" Blue Hex Driver	1
1546	FT 3/32" Gold Hex Driver	1
1547	FT 2.5mm Green Hex Driver	1
1548	FT 3mm Red Hex Driver	1
1553	FT Phillips Silver Screwdriver	1
1554	FT Silver Spring Hook Tool	1
1561	FT Nut Driver Set, (6 pcs)	1
1562	FT 3/16" Black Nut Driver	1
1563	FT 1/4" Red Nut Driver	1
1564	FT 5.5mm Red Nut Driver	1
1565	FT 11/32" Green Nut Driver	1
1567	FT 8mm Gold Nut Driver	1
1568	FT 5.5mm Short Nut Driver	1
1569	FT 7mm Nut Driver, T-Handle	1
1570	FT 7.0mm Short Nut Driver	1
1589	FT 5/64" Blue Ball Hex Driver	1
1590	FT 3/32" Gold Ball Hex Driver	1
1592	FT Ball Hex Driver Set, (3 pcs)	1
1655	FT 8-Piece 1/4" Hex Drive Set	1
1656	FT 1/4" Hex Drive Handle, without tips	1
1657	FT 1/4" Hex Drive .050" Tip	1
1658	FT 1/4" Hex Drive 1/16" Tip	1
1659	FT 1/4" Hex Drive 5/64" - 2.0mm Tip	1
1660	FT 1/4" Hex Drive 3/32" Tip	1
1661	FT 1/4" Hex Drive 1.5mm Tip	1
1662	FT 1/4" Hex Drive 2.5mm Tip	1
1663	FT 1/4" Hex Drive 3/16" Nut Driver Tip	1
1664	FT 1/4" Hex Drive 1/4" Nut Driver Tip	1
1665	FT 1/4" Hex Drive 11/32" Nut Driver Tip	1
1666	FT 1/4" Hex Drive 5.5mm Nut Driver Tip	1
1667	FT 1/4" Hex Drive 7.0mm Nut Driver Tip	1
1668	FT 1/4" Hex Drive 8.0mm Nut Driver Tip	1
1669	FT 1/4" Hex Drive 5/64" - 2.0mm Ball End Tip	1
1670	FT 1/4" Hex Drive 3/32" Ball End Tip	1
1671	FT 1/4" Hex Drive Standard Screwdriver Tip	1
1672	FT 1/4" Hex Drive Phillips Screwdriver Tip	1
1673	FT 1/4" Hex Drive 2.5mm Ball End Tip	1
1674	FT 1/4" 5 Piece Power Tool Tips Set (5/64-2.0mm, 1.5mm, 2.5mm, 5/64"- 2.0mm ball, 2.5mm ball)	1
1719	FT Camber + Track Width Tool	1
1737	FT Body Scissors	1
3718	12 Inch Nylon Wire Ties	12
3719	6 Inch Nylon Wire Ties	12
3720	8 Inch Nylon Wire Ties	12
3987	FT Droop Gauge	1
6429	Shock Building Tool	1
6956	Molded Tools, Set	1
7709	4 Inch Nylon Wire Ties	12
SP29	Team Associated Countertop/Setup Mat	1
SP30	Team Associated Pit Mat	1

Associated Electrics, Inc.
26021 Commercentre Drive
Lake Forest, CA 92630-8853 USA
<http://www.TeamAssociated.com>
<http://www.RC10.com>
[http://twitter/Team Associated](http://twitter/TeamAssociated)
<http://bit.ly/AEonFacebook>

call: (949) 544-7500
fax: (949) 544-7501

Check out the following web sites for all of our electric kits, current products, new releases, setup help, tips, and racing info!

www.TeamAssociated.com - www.RC10.com

:: Trouble Shooting

Description	Problem	Solution
No Power	Battery is discharged..... Battery not plugged in..... No light on speed control.... Receiver LED remains red.	Charge battery. Plug in battery. Reset speed control using your instruction manual. Re-bind transmitter to the receiver.
No Throttle	Motor not plugged in..... Speed control out of adjustment. Motor failure.....	Plug in motor. Reset speed control using your instruction manual. Replace motor.
No Steering	Servo not plugged in..... Locked up steering linkage. Servo failure.....	Plug servo in. Free up steering linkage. Replace servo.
Throttle	Goes backwards when you pull the trigger, or forward when pushing brakes / reverse.	Switch any two motor wires. Check throttle reversing switches on transmitter. Reset speed control.
Steering	Goes right when turning..... the wheel left (or left when turned right.)	Check steering reversing switches on transmitter.
Vehicle is glitching	Vehicle has a problem on.... power:	Check for loose wires or check for or dead radio batteries. Radio interference.
Reverse	No reverse or brakes.....	Check that reverse mode has not been turned off. Refer to speed control instructions. Reset speed control, or send in for repair.
Vehicle dies or slows	Speed control overheats.... Motor overheats..... Gear mesh set too tight..... LiPo mode engages.....	Let speed control cool off. Check gear, gear mesh, or bind in driveline. Let motor cool and check recommended gearing for motor type. Reset gear mesh (see instruction manual). LiPo mode on the ESC has engaged, recharge your batteries. (If running NiMH battery, turn off LiPo mode)