

#29120
XP2
2 CHANNEL AM RADIO

#29121
XP3
2 CHANNEL AM RADIO

Instruction MANUAL



XP2

2 CHANNEL AM RADIO

ae
BY TEAM ASSOCIATED

Introduction

Congratulations on your purchase of the Team Associated XP Series radio system. The all new Team Associated XP2 and XP3 Radio Systems are designed in Taiwan with state-of-the-art IT technology. With proper use and care, the Team Associated XP Series Radio System will make control of your model advanced and simple, and provide you with many years of enjoyment. Before operating your new radio system or installing it into your model, please take a few minutes to familiarize yourself with the various features of the system by reading this owner's manual thoroughly.

Features

Transmitter

- AM pistol grip transmitter
- Available in 2-Ch (Team Associated XP2) and 3-Ch (Team Associated XP3)
- Ergonomically designed steering wheel
- Digital proportional precise control
- Servo reversing
- Steering and throttle trims
- Throttle ATV / Adjustable Travel Volume
- Dual rate steering
- Adjustable neutral position for throttle trigger
- AUX Channel (only XP3)
- LED battery level indicator with low power flashing
- Easy access crystal
- External charging jack for NiCd battery pack
- All SMT circuitry for dependability

Receiver

- Built in BEC (Battery Eliminator Circuit)
- Super-Heterodyne for extra long range
- Interchangeable crystals

Servo

- Most reliable high torque motor
- Dual sleeve bearings support
- Standard size to fit most models
- High impact material

System Contents

Radio System	XP2	XP3
Product No.	29120	29121
Transmitter	XP2	XP3
Receiver	29122	29123
Servos	29124 (x2)	29124 (x2)
Switch Harness	29114	29115
Receiver Battery Holder	29116	29117
Servo Accessory Package - 29118		

Specifications

Transmitter	XP2	XP3
Frequency	27MHz	
AUX	No	Yes
Modulation AM	Pulse Proportional Modulation (PPM)	
Transmitter batteries	AAx8 (UM-3x8)	
Current Drain	200mA@12V	
Dimensions (w/o Ant)	185x105x264 mm (7.28x4.13x10.39in)	
Weight	395g (13.9oz)	
Receiver	TR202A	TR403A
Frequency	27MHz	
Channel	2	4
BEC	Yes	
Single Conversion	455KHz	
Channel Spacing	20KHz	
Receiver batteries	AAx4 (UM-3*4)	
Current Drain	35mA@6V	
Dimensions	48x34x22 mm (1.89 xx in)	
Weight	25g (0.89 oz)	
Servo	S1903	S1903MG
Control	Pulse width control	
Operation Range	+/- 45 degrees (without trims)	
Power Supply	4.8-6.0 V (shared with receiver)	
Current Drain	10mA at idle/ 650mA at stall	
Output torque	3kg-cm (42.18 oz-in)	
Transit Time	0.19sec/60 degrees of travel	
Dimensions	40.9x20.37 mm (1.61x0.78x1.46 in)	
Weight	46g (1.62oz)	51g(1.8oz)

Transmitter Controls

- 1) **Transmitter Antenna:** Never operate the transmitter without extending the antenna or you may create interference to another modeler.
- 2) **Battery Level Indicator:** Three LED display to indicate the battery voltage level. If the Red LED flashes, please replace the batteries.
- 3) **HI/LO Throttle ATV (Adjustable Travel Volume):** The function to let you independently preset the maximum travel of the throttle servo on either side (high / low) of neutral.
- 4) **Servo reversing switches:** To reverse the servo's rotation direction. The reversing switches are recessed into the transmitter to prevent accidental operation.
- 5) **Steering Trim:** Adjusts the steering in small increments or decrements to run the model straight.
- 6) **Throttle Trim:** Adjusts the throttle in small increments or decrements to shift the neutral position.
- 7) **Steering D/R (Dual Rates):** Allows you to adjust steering sensitivity.
- 8) **AUX Ch Button (XP3 only):** Provides an extra function (or channel) for the control of the model movements.
- 9) **External Charging Jack:** Recharges the transmitter battery if you are using a rechargeable battery pack.
- 10) **Crystal:** To change the channel number your radio broadcasts.
- 11) **Steering Wheel:** Controls the steering of the model.
- 12) **Power Switch:** Slide to turn the transmitter on or off.
- 13) **Throttle Trigger:** Pulled or pushed to control the movement of the model.
- 14) **Trigger Neutral Position Lever:** Used to change the neutral position of the throttle trigger.
- 15) **Battery Cover**

HELPFUL HINTS

Crystals: It is recommended that you use only genuine Team Associated crystal sets, and to change both the transmitter and receiver crystal at the same time.

Trigger Neutral Position Lever: This function changes the sensitivity of the throttle servo in the throttle trigger forward side and brake side directions. It has no effect on the servo maximum travel.



Installation

Transmitter battery replacement/installation

Slide the battery cover in the direction as shown to install 8 AA (or UM 3x8) cells into the transmitter. Then, turn the power on to check. If the LED fails to light, check the batteries for insufficient contact or incorrect battery polarity.

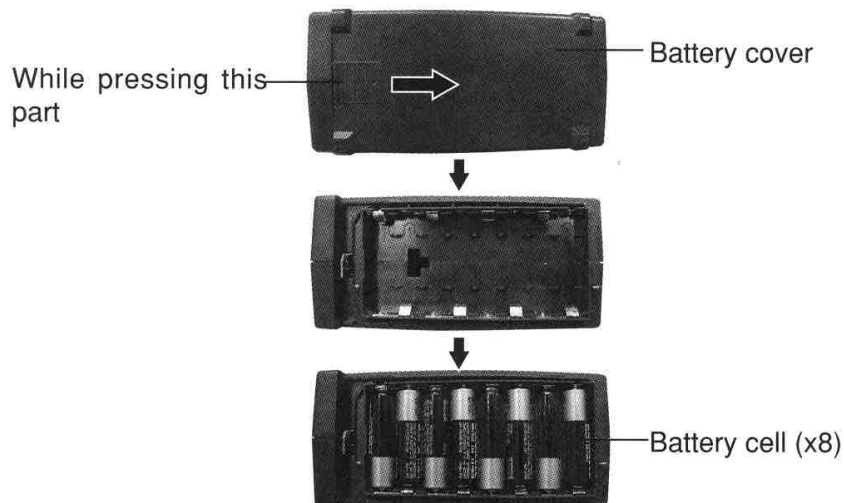

NOTE

Use only fresh alkaline or rechargeable cells, all of the same brand, all the time.

WARNING

Never attempt to recharge ALKALINE batteries or any DRY cells! The transmitter may be damaged and the battery electrolyte may leak or the battery may break.

Always be sure the batteries are loaded in the correct polarity order. If the batteries are loaded incorrectly, the transmitter may be damaged.

HELPFUL HINT

You may also use rechargeable batteries in your transmitter and receiver battery holder. They can be charged with the #29150 plug-in charger (not included with your radio system but available from Team Associated).

Cord to transmitter
external charging jack

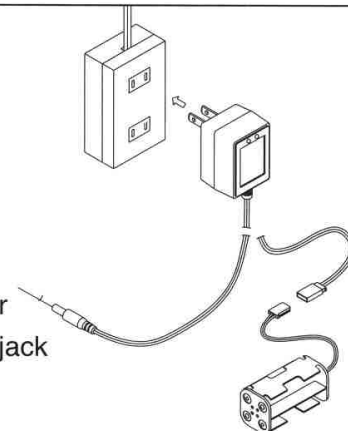

CAUTION

Make certain that the contacts in the battery holder stay clean by using a pencil eraser to gently remove any corrosion or dirt that may accumulate on them. It is recommended to do this each time you install fresh cells into your transmitter.

When the transmitter will not be used for any short or long period of time, always remove the batteries. the batteries are loaded incorrectly, the transmitter may be damaged.

Receiver battery replacement / installation

Insert 4 fresh AA (or UM 3x8) or rechargeable cells into the receiver battery holder. Make sure the batteries are loaded in the correct polarity order. Maintain the battery contacts in the same way as described in the previous section.

Insert the switch harness plug into the receiver socket marked "BATT".

Secure battery holder according to your vehicle instructions. Never operate your vehicle without properly securing the battery holder. Serious damage or injury could result.

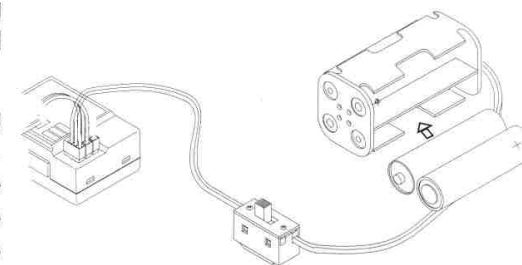

Radio installation

Before installing your radio into your model, connect the receiver, servos and switch harness/battery pack as shown. In addition to checking for proper operation, this "bench test" will help you to become familiar with the operation of your radio. After connecting the model components, extend both the transmitter and receiver antennas to their full length. Begin by turning on the transmitter, then turn on the receiver switch. Make sure that all servos and trim levers are operating, and take a few moments to "play" with your system. After completion of your bench test, turn off the receiver followed by the transmitter.

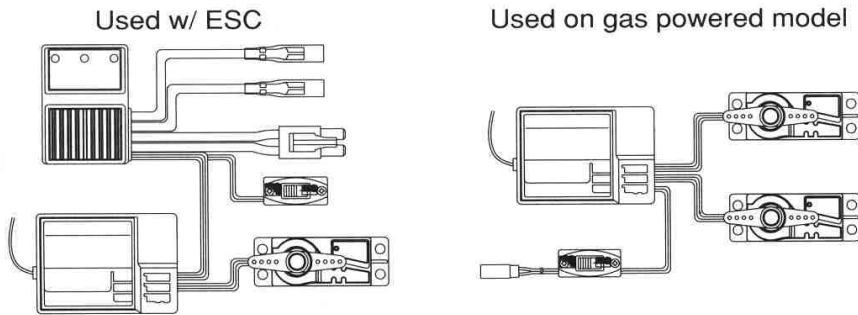

HELPFUL HINT

Your new Team Associated XP2/XP3 radio system provides a built-in BEC (Battery Eliminator Circuitry) function. This feature allows the receiver to draw power from the main battery pack, eliminating the need for a receiver battery.

WARNING

Always follow the *transmitter on first, off last* procedure. If you turn the transmitter off prior to turning off the receiver (or turn the model on before the transmitter), the receiver has no signal and can allow the vehicle to move away uncontrollably. This condition can also damage the servo output gear train because of *jitters* or excessive servo travel beyond normal limits.

Servos

Mount the servos as recommended in your model's instruction manual.

Receiver installation

Note the location of the receiver in your model's instruction manual or building plans.

HELPFUL HINT

Always install the receiver as far as possible from the motor, ESC (Electronic Speed Control), NiCd/NiMh batteries, motor wire or other noise sources. Do not route the motor wire next to the receiver, crystal or receiver antenna.

Noise suppression capacitors should be installed on almost all motors. If the proper capacitors are not installed, high frequency noise will reduce range and cause loss of control along with various other problems. Make sure your motor is equipped with at least two noise suppression diodes or capacitors.

Metal and carbon fiber chassis can also conduct noise. It is suggested that you route the antenna away from the chassis to help eliminate this noise.

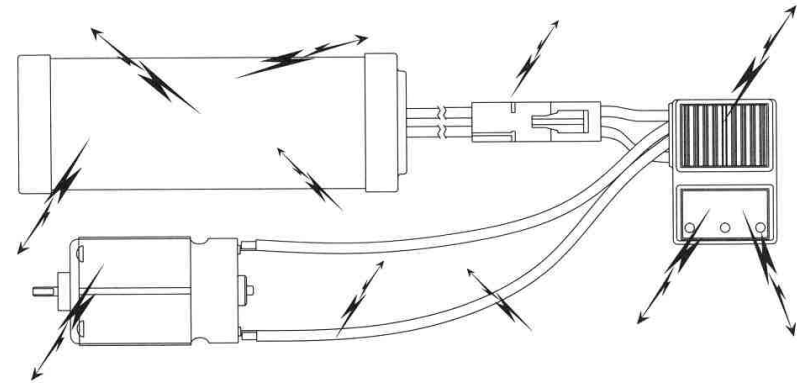

NOTE

FET servo wire from some Electronic Speed Controls (consult your ESC manual) can also generate noise. Position them as far away as possible from the receiver and the antenna.

HELPFUL HINT

Metal and carbon fiber chassis can also conduct noise, it is suggested that you route the antenna away from the chassis.

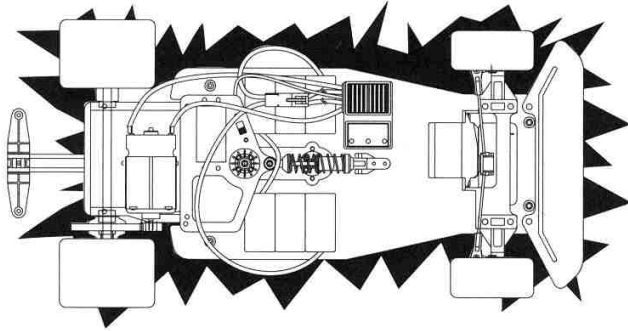

Position the crystal side at the top instead of the bottom side. Please refer to the following diagrams.

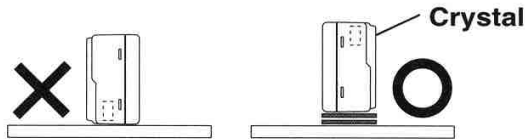

Space available in your model will determine how much padding can be placed around the receiver. R/C foam is made from natural rubber, which eliminates vibration far better than synthetic foam (such as the kind used for packing many consumer items). R/C foam is available from Du-Bro, Carl Goldberg, Sig and others.

CAUTION

The receiver contains precision electronic parts. These parts are vulnerable to vibration and shock.

NOTE

When wrapping the receiver, keep in mind that you are trying to cushion a delicate piece of electronic equipment, so "wrap" the foam, don't "stretch" it around the receiver.

HELPFUL HINT

It is quite simple to isolate the receiver from vibration by attaching it to the chassis or mounting plate with thick, double-sided tape or zip-ties.

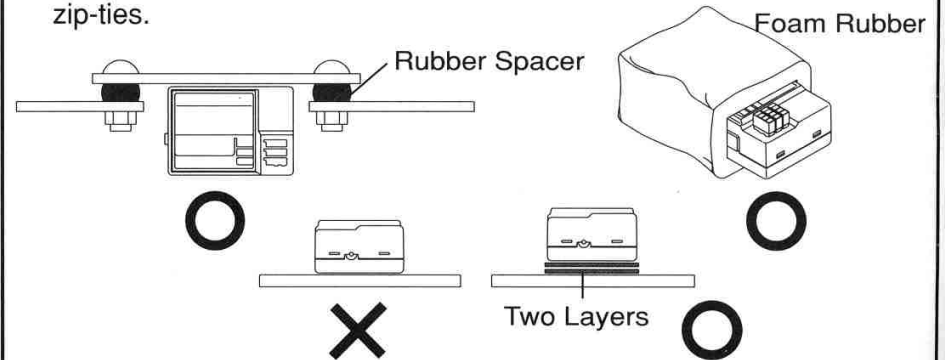

Many modelers prefer to install their receiver into the model at this point with no further protection. Another preferred method is to place the foam-wrapped receiver into a plastic bag or balloon secured with a rubber band around the receiver case as well as the servo and battery wires. The advantage of the plastic wrap is the protection against fuel or oil in the event of a major crash. The disadvantage of the plastic, especially if you run the model in very hot and humid conditions or wet days, is that moisture can accumulate inside the receiver.

CAUTION

Any contact with moisture, i.e. water or condensation, may cause malfunction and loss of control.

HELPFUL HINT

If you choose to wrap your receiver in both foam and a plastic bag, it is recommended to periodically remove the receiver from your model, remove the foam and bag and let the receiver "air out". This maintenance procedure will let you determine if any moisture is accumulating in the protective wrap. Small holes cut into the bag will allow airflow into the receiver, and eliminate the need for the periodic checks, although you will lose a certain amount of protection against fuel or oil with this step.

Battery Installation

Always wrap the battery pack in foam, and mount it securely in the location specified in your models instructions. It is also recommended to wrap the battery pack in a plastic bag or balloon, as its location might be too close to the engine and fuel tank, making fuel proofing vital.

Switch installation

Pick the most convenient location for your on/off switch as required by your particular model. Always mount the switch on the opposite side of the engine exhaust. After mounting the switch, carefully bundle any excess servo wires with cable ties, keeping them away from any moving item (pushrod, servo arm, etc.) that could catch and cut the wires. Any empty space in your radio compartment can be filled with excess foam.

Receiver antenna

Refer to your model's instructions for the location desired for the receiver antenna to exit the Body. A general guideline is to exit the antenna from the Body at the closest possible point to the receiver, that is, have as much antenna as possible outside the model.

Use a strain relief (a knot will work) where the antenna exits the model to avoid the antenna being ripped out of the receiver in the case of a mishap. A rubber band works well for this. **REMEMBER: THE ANTENNA WIRE IS YOUR MODEL'S "LINK" TO THE TRANSMITTER.** Take care to eliminate any chance of the antenna wire being caught or tangled in the wheels, tires, etc.

NOTE

The receiver antenna may seem long. The length of the receiver antenna is critical to the proper operation of your radio. Do not cut or alter, for any reason, the original length of the antenna wire, or the receiver would become considerably more susceptible to interference and high frequency noise, which might severely limit the range of the system.

HELPFUL HINT

Please refer to the following diagrams when you mount the antenna holder on to the metal or carbon chassis.

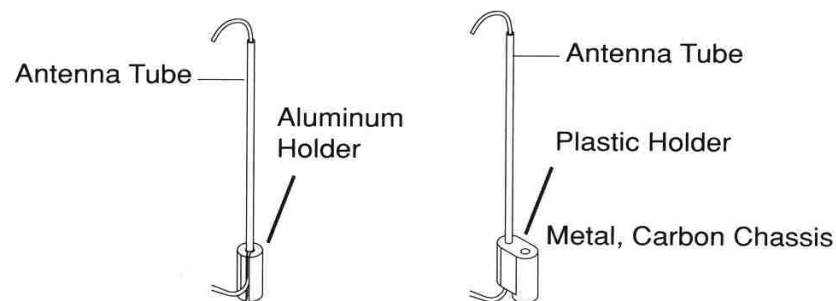

Do not secure antenna wire to the plate.

Functions

Servo Reversing

It is sometimes necessary or convenient to reverse the output direction of the servo. The direction of the rotation for each individual servo can be changed by simply flipping the reversing switch that corresponds to the channel number on the receiver where the servo is plugged in. Under normal

HELPFUL HINT

Install the antenna holder as near as possible to the receiver.

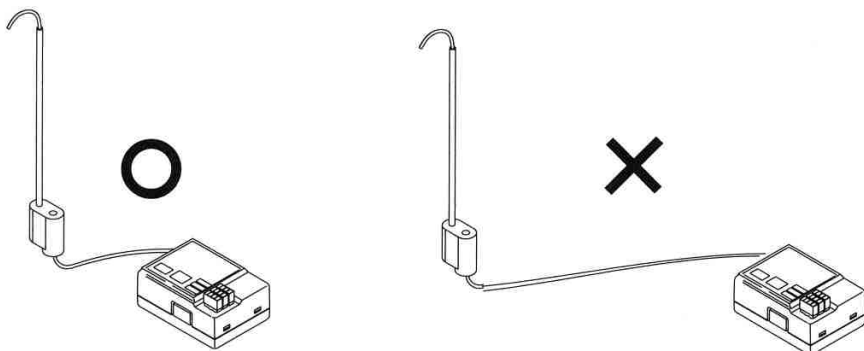

The shorter, the better. It will be easier to get the nearby noise if it is too long.

circumstances, Ch1 is steering, Ch2 is throttle and Ch3 and Ch4 is for extra functions. Use the reversing switches as needed.

Steering Trim

- Neutral position trim

By turning the Steering Trim knob clockwise or counter-clockwise, the steering neutral can be adjusted as needed.

NOTE

Be sure the steering trim on the transmitter is at the neutral position before trying to make an adjustment.

HELPFUL HINT

When you install a servo, always check to be sure that the servo is at its neutral position.

- Servo travel

Changing the trim can affect the overall settings. When adjustments are made with steering trim, it is recommended to re-check your installation for maximum servo travel.

HELPFUL HINT

If it takes most of your trim movement to get a servo to the neutral position, re-position the servo horn or servo saver on the servo and inspect your linkage installation.

Adjustable Throttle Trigger

By flipping the Trigger Neutral Position Lever, 3 positions (as shown) can be chosen to achieve a best operation for your particular model. This function is used to change both the forward and brake-side travel of the throttle servo to get a proper sensitivity.

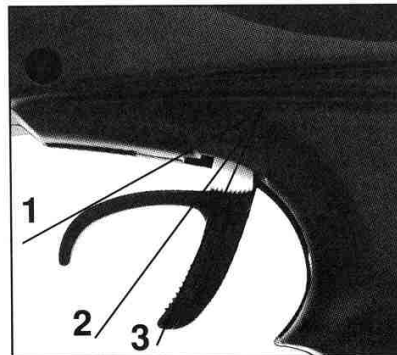

Throttle Trim

- Neutral position trim

Once the neutral position of the throttle is set (by turning the Throttle Trim knob clockwise or counter-clockwise), the throttle neutral can be adjusted as needed.

HELPFUL HINT

When using an ESC, set the throttle trim to neutral and make adjustments to the speed control. On a gas powered model set the trim to neutral and adjust the throttle linkage to the point where the carburetor is fully closed in accordance with your engine instruction manual.

- Servo travel

Trim adjustments will affect the overall servo travel. Check the brake side (backward) movement, especially when changes are made.

HELPFUL HINT

If you have used most of the trim movement to get the servo to the neutral position, re-center the servo horn closer to the neutral position and inspect your throttle linkage.

Throttle ATV

Throttle Adjustable Travel Volume/ATV provides the function to independently preset throttle travel of the servo to either side of neutral. It makes the adjustment easier to set the throttle operation at idle and maximum power.

Steering D/R

Steering D/R allows you to change the steering travel while running the model. By turning the dual rate dial (as shown), you can correct over-steering or under-steering problems by increasing or decreasing steering sensitivity. You are able to tailor the sensitivity of your model to your own preferences with this function.

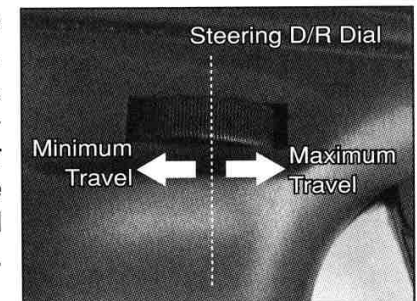

Final Checks

Once you have completed the radio installation to your satisfaction, test the operation of the system before hooking up any push rods or control cables.

Connecting

Check the receiver, servos and battery connectors. Be sure they are firmly connected.

CAUTION

If a connector is not fully inserted, vibration can cause the connector to work loose while the model is running. This will result in loss of control.

Battery Power

Turn on the transmitter. If the red LED (the left one) begins to flash, it is time to change the cells.

HELPFUL HINT

Your new Team Associated XP2/XP3 radio system is controlled by a microprocessor. If the throttle trigger is not at the neutral position when you are turn on the transmitter, an audible alarm will warn you to turn the power off. Make sure the throttle trigger is at neutral and turn the transmitter on again.

Linkages

Once satisfied with the pushrods, attach them to the servo arm/horn per your models instructions. Operate each servo horn over its full stroke and check to see that the linkage does not bind or is not too loose.

CAUTION

Before connecting the pushrods or control cables, make certain that there is no binding or unnecessary drag on the controls. Excessive force applied to the servo horn by binding or poor installation may lead to excessive power consumption by the servos and will quickly drain the receiver pack as well as make your model perform poorly.

Inspect all linkage installations. Make sure any metal parts do not touch other metal parts under vibration.

NOTE

The high frequency noise generated by this contact (metal on metal) can cause interference and possible loss of control.

Adjustments

With all transmitter trim levers set in their neutral position, turn on the radio system and reconfirm proper control directions. Adjust the pushrods mechanically to achieve neutral centered control with neutral transmitter trim.

The design, engineering and production staffs at Team Associated wish you happy running with your new Team Associated XP2/XP3 Radio System.

Frequency List (U.S.A.)

The following frequencies are available. They may be used for any R/C ground model.

27MHz

- 26.995 MHz Brown Flag
- 27.045 MHz Red Flag
- 27.095 MHz Orange Flag
- 27.145 MHz Yellow Flag
- 27.195 MHz Green Flag
- 27.255 MHz Blue Flag

26MHZ

40MHz

Each frequency is assigned a colored flag. Attach this flag to the end of your transmitter antenna so that other modelers can determine your frequency from a distance. This is very important since it is not possible for more than one model to operate on the same frequency at the same time.

FCC Rules and Regulations

You are responsible for the proper operation of your station (transmitter) at all times and are responsible for observations, servicing and maintenance as often as may be necessary to ensure proper operation. Each internal repair and each internal adjustment to a FCC type accepted R/C transmitter must be made in accordance with the technical regulations specified by the FCC. The internal adjustments should be performed by, or under the immediate supervision and responsibility of, a person certified as technically qualified to perform transmitter maintenance and repair duties in the private land mobile services and fixed services by an organization or committee representative of users in those services.

The FCC at this time does not require the modeler to obtain a special license for the operation of this unit. However, it is still the owner's responsibility to observe all FCC rules and regulations governing its use. For a copy of these rules write to:

Federal Communications Commission
Washington, DC 20554

Using Caution at the Racing Track

Always check if there is anyone operating on the same frequency. If so, make sure that you don't turn on at the same time.

- Do not operate the model or use the radio in rain, lightning or at night.
- Do not operate the model or use the radio if you have been drinking alcohol or under the influence of any other substance that will affect your skills.
- Always check battery power before operation.
- Always keep your transmitter clean. Wipe it with a mild detergent or window cleaner if there is any fuel, oil, dirt or dust on the transmitter.
- Keep out of reach of children.
- Do not store the radio in temperatures below -10°C (14°F) or above 40°C (104°F) or in a humid, dusty or high vibration environment. Keep the radio away from direct sunlight.
- To prevent corrosion, take out the batteries if you are going to store the radio for a long period.
- The servos will glitch at $\pm 25^\circ$ if there is any frequency at about 200-250MHz nearby when using this radio.

XP2 / XP3 Accessories



- 29120 XP2 Transmitter Only w/o Crystal
- 29121 XP3 Transmitter Only w/o Crystal
- 29102 XP2/XP3 Transmitter Antenna

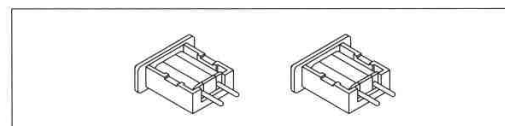

- 29108 AM26.995MHz Crystal Set Ch1-Brown
- 29109 AM27.045MHz Crystal Set Ch2-Red
- 20110 AM27.095MHz Crystal Set Ch3-Orange
- 29111 AM27.145MHz Crystal Set Ch4-Yellow
- 29112 AM27.195MHz Crystal Set Ch5-Green
- 29113 AM27.225MHz Crystal Set Ch6-Blue

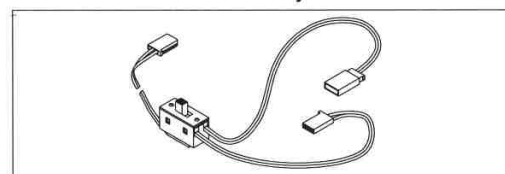

- 29114 BEC Switch Harness for TR202A
- 29115 Switch Harness for TR403A

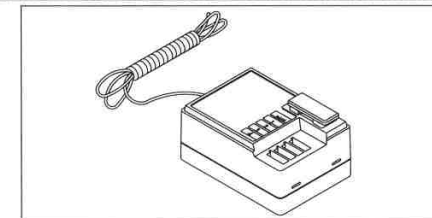

- 29122 TR202A 2Ch AM Receiver
- 29123 TR402A 4Ch AM Receiver

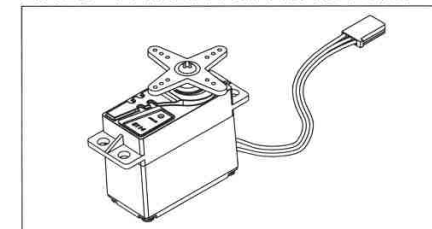

- 29124 AE R/C Servo S1903
- 29125 AE R/C Servo S1903MG
- 29107 Servo Gear Sets/Metal
- 29126 AE R/C Servo S2008MG

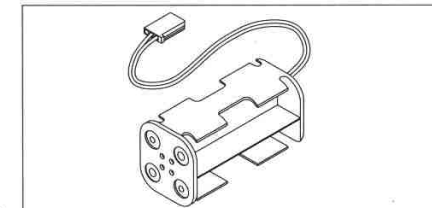

- 29116 4 Cell Battery Holder for TR202A
- 29117 4 Cell Battery Holder for TR402A

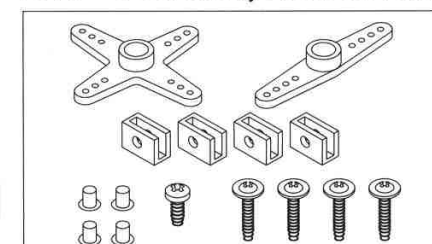

- 29118 Servo Accessory Package

Service

All Team Associated products have been carefully inspected prior to shipment. However your Team Associated XP2/XP3 Radio System is warranted to the original purchaser for one full year from the date of purchase against defects in materials and workmanship. During this period, Team Associated will repair or replace, at our discretion, any defective components. This warranty is for the original product only and does not extend to any model car/boat, engine, property or persons. Under no circumstances will the buyer be entitled to consequential or incidental damages. This limited warranty gives you specific rights. You may also have other rights, which vary from State to State.

Radio Equipment Servicing

Keep a copy of this information with Your Original Sales Receipt

DO NOT return the equipment to the place of purchase as they are not authorized to honor the warranty. Remove the radio equipment in question from the model. Do not send the entire model.

Include With Your Return:

- 1) **Your Name, Address and Daytime Telephone Number.**
- 2) **A note describing the problems (in detail) you are having** or the service you are requesting **IN THE PACKAGE.**
- 3) **A copy of your original sales receipt showing the purchase date.**
- 4) **Method of Payment for service charges.**

Check one: MasterCard Visa AMEX Discover

_____ Exp. Date _____

Money Order Enclosed

If the product has been modified or serviced by anyone other than an authorized service center, you will be charged for the repair of your equipment. Modifications, which impede normal servicing, will be removed at your expense. You may request a free estimate before we proceed with repairs. An omission of this request implies permission for service at discretion. When sending the unit by US Mail or United Parcel, package it in a strong cardboard box. Do not include any accessories which you added that are not an original part of the product. You are responsible for all postage and handling charges.

- 5) **Send the unit by United Parcel Service or by insured U.S. Mail to:**

**Associated Electrics, Inc.
3585 Cadillac Ave.
Costa Mesa, CA 92626-1401 USA**

- 6) **Outside of the USA, contact 1-714-850-9342.**

Trouble Shooting

Do not try to operate your model if you find your radio is not working properly. Check out the radio as shown in the following steps. If you can not solve the problems, contact an authorized tech support representative for help. For customers in North America, please contact Team Associated for service.

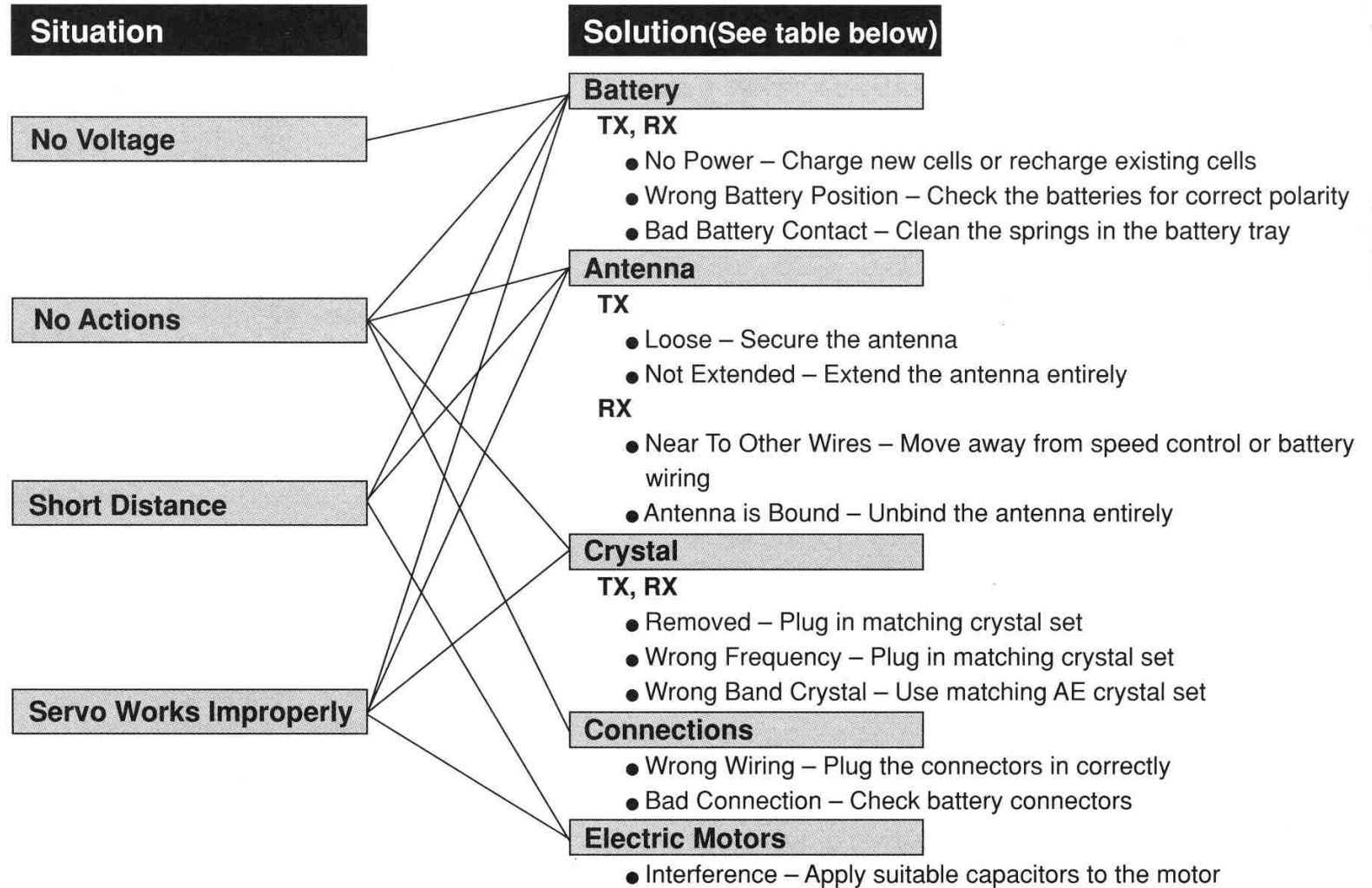

Distributed in North America by

Associated Electrics, Inc.

3585 Cadillac Ave., Costa Mesa, CA 92626-1401 USA

www.teamassociated.com

