

AE TEAM ASSOCIATED

RC 500

Instructions

Congratulations! You have purchased one of the finest 1/8 scale R/C cars ever made. We believe it is the best 1/8 car in the world for a number of reasons. The RC 500 placed 1st and 2nd at the USA ROAR Nationals in the Can Am class, and in England the RC500 won both the Formula class and the Coupe class at the English Nationals.

The RC500 is not just another independent suspension car. If a tire can move up and down, independent of the chassis, then that classifies it as independent suspension. There are many 4 wheel independent suspension cars available. However, the RC500 was the first 4 wheel independent suspension 1/8 gas R/C car designed with the same basic suspension system as the **real** 1/1 scale Formula race cars. The RC500 was designed to handle like a real racing car, making it the first **racing** independent suspension car available.

The RC500 was basically designed by World Champion Phil Booth and world renowned designer/racer Dave Preston, both from England. Dave had raced full sized Formula cars for years and was thoroughly familiar with chassis, suspensions, and design theories of the real Formula cars. So when Dave and Phil designed the basic RC500, they copied exactly all the suspension geometry, "A" arm lengths and locations, ride heights etc. from the real Formula race cars. Then Associated teamed up with Phil and Dave to produce the car and added some further improvements, such as the coil over shock suspension.

We feel you are starting with the very best 1/8 scale race car available. Your performance with the car will depend entirely on you. We want you to be able to go as fast as your potential allows. So we've prepared the most complete set of instructions ever, to make it an easy, as well as enjoyable, experience assembling and racing this car.

I know you're anxious to get on with building the car, but this is the time that will determine how successful a racer you will be. I'm sure you've heard the old saying that the race is won in the garage. It means that careful car preparation

in the garage, is what helps to determine the winning cars. Rather than by seeing if you can be the fastest assembler in the world of an RC500 car, it would be much better for you, if you took your time and was the **best** assembler of an RC500 **race** car. There's a **big** difference.

You'll notice in the photo section of the instructions, that it will be quite easy to assemble the car, because of the over 100 photos, as well as drawings included in here. As a matter of fact, it's going to look so easy to some of you, you'll probably want to assemble the car by the photos only. What you'll end up with is an assembled RC500 car. Good luck - you'll need it. For the rest of you who want to do the job right, take your time, follow all the instructions and you'll end up with a race winning RC500 **race** car.

FRONT END ASSEMBLY

Do not open up all the parts bags and dump all the parts together. Only open up the parts bag that you are about to assemble.

Refer to **Photo #1** - Using an Exacto knife, trim about 1/16" off of the #5013 right and left steering arms for added wheel clearance.

Photo #2 - Assemble the steering arms to the #5108 steering blocks as shown. Be sure to use 2 lockwashers on each screw. If the screws go in exceptionally hard, to the point that you think they might break off before they are fully seated, then remove the screws, and cut a small amount off of the screws with a Dremel cut off disc. A little oil on the screws will make installation easier.

Photo #3 - Take the #5100 front bulkhead and install the two shock mounts as shown.

Photo #4 - Trim the 2 lower "A" arms with an Exacto knife, or Dremel tool to make the 1/8" holes slightly elongated instead of round so the anti-roll bar can move inside to outside, but not up and down.

Photo #5 - Trim the #5101 L lower "A" arm as shown to clear for shock installation. Incidentally, the left and right sides of the car are determined from the drivers seat position. As the

driver is sitting in the car, his left hand side is the car's left side.

Photo #6 - Trim the #5101 R lower "A" arm as shown.

Photo #7 - The ball ends on the #5108 steering blocks are hard anodized for long wear. They are quite smooth. However, if you want a polished finish for smoother operation, you can polish the ball ends with #600 wet or dry sandpaper. Only sand about 10 seconds. You only want to polish, but not to sand away all the anodize. Then install two of the #5104 ball cups on the upper ball as shown. Now slip the thin steel locking washer over the two cups.

Photo #8 - Slip the #5102 R upper "A" arm over the cups and install the locking ring with a snap lock ring pliers. Do not open up the snap ring more than necessary or you will distort it out of shape.

Photo #9 - Now install the cups and locking washer on the other ball end.

Photo #10 - Install the #5101 R lower "A" arm as shown.

Photo #11 - Now install the complete left side arms.

Photo #12 - In the front end package there are four 1/8" pins for mounting the "A" arms to the bulkhead. With your Dremel, grind two flat spots on one end of the pins to make it easier to grip with a pliers. If these pins should loosen up while running the car, you can put a set screw in the bulkhead where the pin goes through, to keep the pins from moving.

Photo #13 - Slip the lower L pin through the lower L "A" arm and then through the bulkhead. You'll notice the pin goes through the arm quite easily so the arm can swing freely on the pin. However, the pin will go in the block very tightly. Now use your pliers and twist the pin back and forth as you slip it through the bulkhead. Now install the upper "A" arm with the shorter pin. You'll notice the arm is wider than the bulkhead. Place one of the small plastic camber spacers between the rear of the bulkhead and the "A" arm.

Photo #14 - Install the R side.

Photo #15 - Remove the lower end of two of the shock absorbers. Be careful and hold the parts tightly, because when you loosen the set screw with the allen wrench, the spring will shoot the end off.

Photo #16 - Unscrew the top end off both shocks.

Photo #17 - We're now ready to fill the shocks with oil. You'll be able to find what you need in auto supply stores. Wynn's Gear Oil Treatment for Differential and Manual Transmissions comes in a tube as shown in the photo. This is about the right starting consistency. By poking a small hole in the end, filling the shock is quite simple. If you cannot find Wynn's, then get a can of STP for motor oil and a pint of 140 weight gear oil. A 50-50 mixture of these two is also a good starting point.

Hold the shock upright, as shown in photo. Make sure plunger is all the way to the bottom and very, very slowly, fill the shock to the bottom of the inside threads. **Do not** fill it to the top. You want to fill it slowly so no air bubbles form in the oil while you're filling it. Excessive air bubbles will make the shock jerky instead of smooth. Too little oil in the shocks will cause the shocks to operate too jerky or too loosely. Too much oil will not allow the plunger to collapse all the way.

When you've got the shock filled to the bottom of the threads, look in the oil and see if you can see any air bubbles. If you can see even the smallest air bubble, then use a small pin and work **all** the air out. Now put the top end back on and with two pliers, tighten both ends. Be careful and do not strip out the threads.

Hold the shock upright, and move the plunger up and down. If it feels the same from top to bottom, you've done a good job. If it feels jerky in its movement, you've got too much air inside. If the plunger won't go all the way up and down, then you've got too much oil inside.

Photo #18 - Now fill the other shock the same way.

Photo #19 - Cut about 1/4" off of two springs.

Photo #20 - Install the springs back on the shock with the cut end towards the top. Install the bottom ends on the shocks. Install a rubber grommet in each end of the shock, and then install a brass tube in each rubber grommet.

Photo #21 - Install the shocks on the front end as shown. Install the rear lower one first with the locking collar. Then on the rear shock, put the upper shock mount in place and see if you've trimmed enough off the #5101 R lower "A" arm to clear the shock. If so, install the upper shock mount with screw and nut with a washer before the nut. Install the forward shock.

Photo #22 - Assemble the servo saver and tie rod ends with instructions found with the servo saver. Install on front end assembly as shown.

Photo #23 - Install the ball bearings in the front wheels. Slip the wheels on the axles. If they go on easily, take them back off, we'll be installing them later. If the ball bearings go on a little tight, then sand the axles with #600 wet or dry sandpaper, until the bearings will go on easily. Later, when you install the wheels, install the thick aluminum washer first, as a spacer, then the wheel, then the thin steel washer, and then the locknut, as shown.

BALL DIFFERENTIAL ASSEMBLY

Photo #24 - With a Dremel, grind a small bevel at the outside end of the #5360 L drive hub. If there are any large shavings inside the other end of the hub, remove them.

Photo #25 - Now bevel the #5362 R drive hub

the same way. Now you must thoroughly clean away all grindings. Use cleaning solvent, or acetone, or methanol, etc. Do a good job. You can spray some WD40 or Tri-Flon on the parts to prevent rust.

Photo #26 - Take the large chain sprocket, #5366 and install the ball cups #5368. Install the cups so every other cup goes in one side, and the next cup goes in the other side. So 6 cups will go in from the left side and the other 6 cups will go in from the right side. Then install the center plastic bushing.

Photo #27 - Now take the gear sprocket and sand the plastic cups on both sides on #400 sandpaper to knock off any high points. Blow off the excessive plastic.

Photo #28 - Now place the 12 balls in the cups. In your kit is a tube of Associated Diff Lube #2780. Put some of this grease on the balls on both sides of the sprocket.

Photo #29 - Take the #5364 brake hub and put some diff grease inside the brass bushing and a very little grease on the #5362 R drive where the brake hub slips on.

Photo #30 - Slip the brake hub on the axle driver and wipe off any excess grease.

Photo #31 - Slip the #5365 inner hub on the shaft. Do not use grease here.

Photo #32 - Slip the first #2863 large steel washer on the #5365 inner hub.

Photo #33 - Slip the chain sprocket carefully over the 3 pins. Now push the #5372 plastic bushing inside the #5361 outer hub. Then put the 2nd large steel washer on the #5361 hub.

Photo #34 - Place the #5361 hub on the shaft. It should be able to spin freely. A little grease inside the plastic bushing is good.

Photo #35 - There are two shiny steel thrust bearing washers. Place the one with the largest diameter on the shaft first.

Photo #36 - Coat both sides of the #2866 roller thrust bearing with a lot of diff grease and install bearing on shaft.

Photo #37 - Slip the other steel washer on the shaft. Then slip the 3 coned washers on the allen screw so the small coned end is towards the bolt head.

Photo #38 - Put the screw in the shaft and tighten the screw with the adjusting wire. Only tighten the screw until the parts seat. Do not overtighten now. We'll be adjusting the diff later, using the same wire.

Photo #39 - Install the L axle driver with the 4 allen screws. Tighten securely.

Having felt all the differential parts, I'm sure you're probably already thinking about where you can grind some weight off. Having assembled the diff already, perhaps you should run it first and then lighten it at a later date.

REAR END ASSEMBLY

Photo #40 - Take the #5250 rear pod and

install the #5357 fiberglass stiffener with the 2 screws and nuts.

Photo #41 - Drill a #43 drill through the rear bumper mounts on the L & R rear bulkheads. Only drill through the outside part. Then take a 4/40 tap and just start the tap in the hole. Don't tap all the way through the hole.

Photo #42 - Take the #5251 R bulkhead and trim around the outside of the large bearing hole. This will make the bearing easier to install. Do the same thing with the L bulkhead.

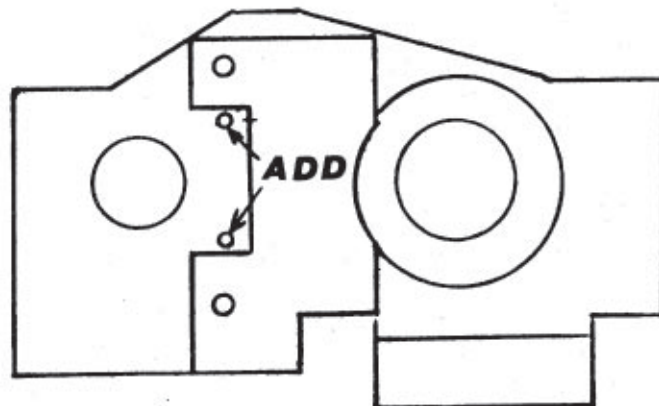

Photo #43 - Install both brake pins in the R bulkhead. Slip one of the #5238 brake shoes on the pins. Drill 2 #43 holes in the bulkhead in the position shown above. Tap the 2 holes for 4/40 threads, but only 2 threads deep. Do not tap all the way through. Remove brake shoe. Install both large ball bearings in both bulkheads.

Photo #44 - Put the R bulkhead on the power pod and install both mounting bolts. Do not tighten the nut on the long bolt. On the short bolt, place an aluminum washer on the bolt, then the locknut. Tighten the nut down till it just stops. Do not overtighten because you'll distort the idler shaft bearing hole.

Photo #45 - Try to slip the #5328 brake shoes and the fiberglass spacer on the brake pins. If they hit on the bottom, then grind some of the bottom of the brake shoes off until they go on easily.

Photo #46 - Take the two #5239 fiberglass brake rotors and sand them down slightly on #400 sandpaper. Sand off all the shiny part on both sides. Then using a micrometer, check the rotors all the way around to make sure they're the same thickness all the way around. Sand down the high sides. Try to slip both brake rotors onto the ball diff. If they are a little tight going on the ball diff, take an Exacto knife and slightly open up the big hole in the brake rotors.

Photo #47 - These are the parts in the order we'll be installing them.

Photo #48 - Put the #5363 bearing spacer in the bearing.

Photo #49 - Slip the fiberglass spacer on the 2 brake pins.

Photo #50 - Next, install one of the #5238 brake shoes. Now take the 2 roundhead 4/40 screws

and install them in the 2 holes you made in Photo #43. This is to hold the fiberglass spacer and brake shoe tightly against the bulkhead.

Photo #51 - Now, one of the #5239 brake rotors. Take a piece of silicone fuel tubing, cut 2 pieces 1/16" long and slip them on the 2 pins.

Photo #52 - Another brake shoe.

Photo #53 - Another brake rotor, and then 2 more pieces of silicone fuel tubing 1/16" long on the 2 pins.

Photo #54 - The last brake shoe.

Photo #55 - Align both brake rotors so that the pin holes are in line with each other. Now, very slowly and easily slip the ball diff through the brake rotors into the ball bearing. If you have everything lined up correctly, it will slip in easily. Do not force it because you'll bend or break something.

Photo #56 - Your diff is now installed.

Photo #57 - Take the chain and bring both ends close together and slip the "U" link with the 2 pins through the chain. Now put the end plate on with the 2 holes in it. Now slip the locking spring clip in place over both pin ends. Be careful. It can fly.

Photo #58 - You now have a one piece chain.

Photo #59 - Slip the chain over the big sprocket.

Photo #60 - Put the L bulkhead on. slip the screws in. Put the stamped steel locknut on the short screw. Do not tighten yet.

Photo #61 - Slip the #5240 brake cam in the hole in the pod plate, so the cut out side is towards the shoes. You can put some diff grease on the brake cam where it goes into the pod plate. Put the ball bearing in the #5254 brake bracket, with the flange down.

Photo #62 - Place the brake bracket on the 2 bolts. Then put one aluminum washer on each bolt. Then put the 2 lock nuts on and tighten down, but **do not** overtighten. If you just keep on tightening down on the nut and if you're not careful you'll distort the plastic out of shape.

Photo #63 - Take an 8/32 tap and just cut 2 threads in the 4 mounting holes in the rear of the bulkheads as shown. **Do not** tap all the way through. We just want to make a couple threads to start the screws, then we want the screws to screw directly into the plastic.

Photo #64 - Put the #5253 rear shock mount plate on with the 2 short screws in the upper holes as shown. Be **extremely** careful not to overtighten these screws. As soon as they start to tighten up, be sure to stop.

Now, take hold of the diff and see if you can slide it from left to right in the large ball bearing. If the whole diff seems to slide more than .025 from side to side, then you'll have to remove the diff and install the thin spacer washer on the right hand side of the diff to eliminate the excessive end play. Then re-install all the parts again.

the bulkhead. You should be able to push it in with your little finger. If it goes in too tight, you'll damage the bearing. You may have to run a 1/2" drill through the hole. As a last resort you could use an Xacto knife and very finely shave a little out of the top and bottom of the hole (but not the front or back), to fit the bearing.

Photo #66 - Grind 2 flat spots on the #5233 idler shaft as shown. don't grind too deep. Notice where the horseshoe clip goes. Install the horseshoe clip.

Photo #67 - Remove the lock nut on the short bolt in the pod so you can install the ball bearing in the L bulkhead for the idler shaft. Then just start the shaft through the bearing. Now take the #5232 small chain sprocket, and put it inside the chain. Hold the sprocket inside the chain and slip the idler shaft through the sprocket. You'll have to do this very slowly and carefully. Keep the sprockets and chain in line, and in place and continue sliding the idler shaft all the way through, until it goes completely through the bearing in the R bulkhead.

Photo #68 - With the idler shaft completely inserted, place the locknut back on the short bolt in the pod and tighten down. Do not overtighten.

Hold the big sprocket and turn the sprocket around a few times. Then see if the teeth in the small sprocket are **perfectly** centered in the chain. If they are **not**, then slide the small sprocket on the shaft until the small sprocket is centered in the chain. Turn the chain through a few more revolutions and check the small sprocket again. If the small sprocket is centered now, put a set screw in the small sprocket and tighten it down on the flat area.

Photo #69 - Take the #5247 gear hub and tap the 3 drive pins in.

Photo #70 - Slip the gear over the gear pins on the gear hub. Now place the #5246 gear spacer on the idler shaft. Put the spacer on with the small flange towards the bearing and the smooth side towards the outside as shown.

Photo #71 - Slip the gear on the idler shaft and adjust the gear location so that there is just a very small amount of sideways play in the idler shaft and then tighten down on the set screw.

Photo #72 - Take the two #5265 rear stub axles and grind the inside edges lightly as you did earlier. Then thoroughly clean the parts.

Photo #73 - Take the two #5264 hub carriers, and with an Exacto knife, bevel the inside and outside edges to allow easier bearing installation.

Photo #74 - Push one of the ball bearings in the outside end as shown.

Photo #75 - Now take the stub axle and slip a ball bearing on the stub axle. Next, slip the aluminum spacer on the axle. Now put the axle in the hub carrier. Push in with your hand and seat the 2nd bearing. Install the bearings in the other hub carrier.

Photo #76 - Take the #5262 R lower "A" arm



ADD TO PHOTO #64

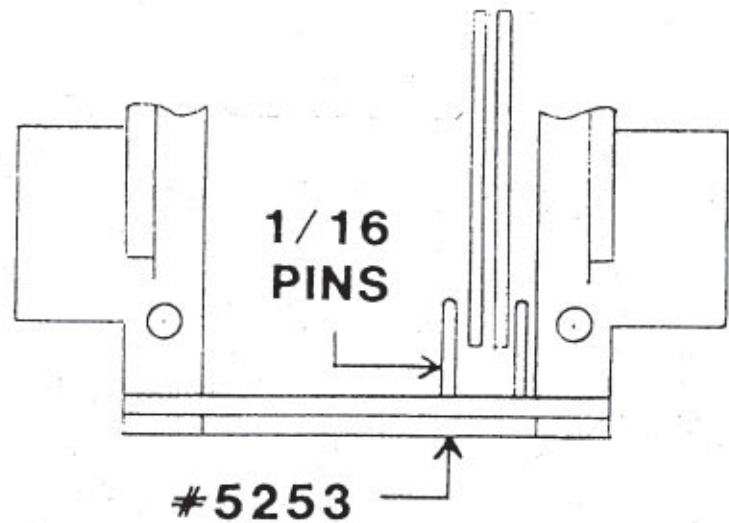

PHOTO #64

Install the two 1/16 pins in the #5253 rear shock mount. Tap the pins in from the front side of the mount, as shown above. These 2 pins will help to eliminate brake drag in the carb open position.

Continue with Step #64 on Page #4

STEP #97 - RIDE HEIGHT ADJUSTMENT

The normal ride height of the car is determined by the position of the LOWER front "A" arms #5101 and the LOWER rear "A" arms #5262.

Both the front and rear LOWER "A" arms should be HORIZONTAL when the car is racing on the track. This can be checked on the bench by taking the completed car, without the body on and starting with the front end, lift the front end only about 2" off the bench and then let the front end drop to the bench. Where it settles, will be close to the ride height of the car on the track. Look at the LOWER front "A" arms. They should be horizontal. If the chassis is sitting too high, you'll have to shorten the shock springs. If the chassis is too low, you'll have to use longer springs. The spring adjustments can be made much easier with the #5134 spring adjusting collars. The #5133 firm springs work very well on the front end. Also, a 1/8" front anti-roll bar is a good starting point. When you have all the adjustments finished, you should be able to lift the front end and drop it on the bench and the LOWER "A" arms should be horizontal. To set the rear ride height, the same procedure is used. Pick up the rear end 2" and drop the rear end on the table. The LOWER rear "A" arms #5262 should now be horizontal. Adjust the springs so the LOWER rear "A" arms will be horizontal after the rear end is dropped from 2".

VERY IMPORTANT - If the rear ride height is set too high, you will wear out the #5270 driveshafts, at a very fast rate. When the rear ride height is correct, there will be no wear on the driveshafts.

The #5132 medium springs work well on the rear. A 3/32" or smaller rear anti-roll bar works well on the rear.

Now adjust the tweak per instructions on page #9.

should be a loose fit. If it is a snug or tight fit, then trim the #5262 R lower "A" arm in the location shown.

Photo #77 - Now take the #5260 R upper "A" arm and slip the other hub carrier mount in it. If it is also tight, then trim the #5260 R upper "A" arm in the location shown. Now do the same thing on the L parts.

Photo #78 - Grind the flat spots on the 8 hinge pins, as you did earlier. Then install the upper and lower "A" arms on the hub carriers, as shown. Now check to make sure they're perfectly free.

Photo #79 - Slip the #5262 lower "A" arm on the bulkhead. If the arm hits the #5250 pod plate, then trim some of the lower "A" arm in the location shown.

Photo #80 - Slip the lower "A" arms on the bulkheads and install the 2 pins. Make sure this joint is free. Next we'll install the #5270 driveshaft, which are sometimes also referred to as "dog bones". Slip one of the rubber boots over each of the driveshafts. The driveshafts and related parts are laid out in the photo, exactly as they must be installed in the car. This is important. Starting with the left side. Slip one of the #5273 plastic spacers into the left hand #5265 rear stub axle. Now fill half of the stub axle with the #2780 diff lube (grease).

Now place the driveshaft in the stub axle and pull the rubber boot up over the flange on the stub axle.

Now install the other plastic spacer inside the #5360 diff left axle driver.

Cut 1/4" off of each end of the spring. The spring must be installed correctly. Install the spring in the diff driver so the end of the spring you just cut, goes in first. Now fill 1/2 of the diff driver with grease. Put the other end of the half shaft in the diff driver and then put the top 1/8" pin in the upper "A" arm.

The right hand half shaft is installed exactly the same way, except there is only one plastic space used in the right stub axle.

Make sure the left and right suspensions move up and down freely.

Photo #81 - The installed rear suspension should look like this.

Photo #82 - Take your Exacto knife and trim a little off the shock mount where it hits the screw head on both sides.

Photo #83 - Now trim the area shown in the photo to clear the shocks, as you did on the front end.

Photo #84 - Look at photo #85. It shows the installation of the rear anti-roll bar. Photo #84 shows a simple wire bending tool which you can make, or you can use a bench vise or pliers. Make sure before you make the 2nd bend that you slip the two #5280 rear anti-roll bar mounts on the wire.

When you have the wire bent to the correct shape, use a flat table and hold the 2 plastic roll

bar mounts flat on the table. The 2 ends of the wire should be measured so they're both absolutely horizontal with the table. If the 2 ends are not parallel to each other, then you will be tweaking the rear end when you install the anti-roll bar.

When you have the bar right, install it on the rear end.

Photo #86 - Turn the rear end up-side down and drill four #43 holes in the center of the four holes in the fiberglass stiffener. Install the 4 screws.

Photo #87 - Fill the other 2 shocks, as you did before, but **do not** cut the springs this time.

Install the shocks with the bolts and nuts and place the two brass tubes inside the lower bolt holes in the plastic mount, as shown. Check the upper shock mount for clearance.

Photo #88 - Your shocks should look like this installed. Bend your rear bumper and install. At the point where the wire goes into the plastic grind a flat spot on each side and install two 4/40 set screws in the holes you drilled earlier. Now be careful on tightening the set screws because they will strip out the plastic very easily. Just tighten the set screws until you just start to feel them tighten up - and stop.

Now we'll install the two steel wing tubes #2201. Round off the ends of the wing tubes with your Dremel so they will not cut the plastic when you install them. Now gently tap the wing tubes in the 2 holes as shown. Now slip the 2 #5255 rear body mounts over the tubes and secure in place with the 2 set screws. Later on, adjust the body mounts so that when the rear wheels are fully extended upwards there is 1/8" clearance between the body and tires.

Photo #89 - Take the flywheel and tap the 2 dowel pins in the 2 smallest holes. The pins will go in very tight, so as soon as it seems the pins do not want to go in any further, stop using the hammer. Now, cut off the pins with your Dremel so they only stick up .430. This is the same distance as the hex portion of the #5200 clutch nut.

Install the flywheel on your engine with the instructions in the flywheel package. Tighten the clutch nut securely.

Slip the 2 clutch shoes on the pins in the direction shown only. Put the 2 ball bearings in the clutch bell and slip the clutch bell onto the clutch nut. The clutch bell should be able to spin very freely over the clutch shoes. If the bell will not go on, or the bell does not spin freely, then you will have to trim the **inside** of the clutch shoes, where they touch the clutch nut, so that the 2 clutch shoes will be able to close down farther. Just cut some small "V's" in the clutch shoes at the points where the corners are on the clutch nut. When the bell spins freely, install the bell with the snap ring.

Photo #91 - Install the motor mounts on your engine as shown. Tighten the 4 allen screws securely.

Photo #92 - Place the motor on the power pod and install the 4 mounting screws, but do not tighten the screws yet. Slide the motor back so the 2 gears touch. Now check to see if the carburetor and muffler clear the chain and everything else.

Please note: Some carburetors will clear everything quite easily. If your carb is too close to the chain, then we suggest you install a carb extension tube, as shown in the photo. These are available from Associated.

Setting the gear mesh. We want the gears to be as close together as possible, without actually pressing against each other. Slide the motor back and forth until you have the gears set, so that if you hold the plastic gear perfectly still, you will be able to rock the clutch bell gear back and forth the smallest possible amount.

If the gears are too tight, you will have clutch bearing problems. If the gears are too loose, it might be possible to shear some teeth off of the plastic gear. We'll get into gear ratios and clutch tuning later. Tighten down the 4 motor mounting bolts. Re-check the gear mesh.

Photo #93 - Tap the 3 drive pins in the #5299 rear wheel hub as shown. Then take your Exacto knife and trim about 1/16" off of the center part of the wheel hub, as shown. This is a little longer than need be.

Now you can install the rear wheels. The rear wheels can be installed in 2 directions. If you will look inside the wheel, you will see that one side of the wheel is smooth, but the other side is ribbed. You can install the wheels whichever way you like. Install the wheel, then the large aluminum washer and then the lock nut.

Photo #94 - Your installed wheels should look like this.

Photo #95 - Radio Tray - Your radio tray must be assembled now. Refer to the radio tray template, which shows the locations of all the parts. The large holes in the radio tray for the fuel tank and servos can be easily cut out with the use of a "coping saw". These are inexpensive and are available in hardware stores. Draw out the location of the large hole for the fuel tank and drill a 1/4" hole in the center. Then remove the blade from the coping saw, slip the blade through the 1/4" hole in the radio tray, and then reassemble the saw and cut out the hole. You can file the cut out to a perfect finish later.

Assemble the radio tray as shown on the next photo page, and the other photo pages.

The forward fuel tank mounting bolt must be installed with the bolt head on the bottom side of the radio tray for servo saver clearance.

The receiver is suspended between the 2 plastic mounts with rubber bands. Then 2 plastic tie wraps are installed around the receiver and around the rubber bands. 2 more tie wraps go around the rubber bands between the mounting posts and the receiver.

The long plastic tube for the antenna mount should be used in its full length. Do not shorten

it. Install the antenna tube in the radio tray with the 2 nuts. After the receiver is installed, feed the antenna wire up through the plastic tube until 1" sticks up through the top of the tube. Now tie a knot in the end of the antenna wire so it can not pull back down through the tube.

Install your servos in the position shown.

Install the batteries next. Place the battery pack on the radio tray where shown. Use the white servo tape between the batteries and radio tray. This helps to isolate the batteries from vibration.

Most radios are designed to use a 4 cell battery pack for the car. This is O.K. However, much faster response can be obtained from the servos with the use of a 5 cell battery pack. A word of caution - check with your dealer first about the advisability of using a 5 cell pack with your particular radio.

One of the most popular radios being used now, is the Airtronics Model #9121 steering wheel radio with the #554 heavy duty servos. This is an excellent radio and can be used with a 5 cell pack. The Futaba FP-2F with S27 servos can also be used with a 5 cell pack.

Now back to Photo #95. Take the #5174 chassis plate and place it under the pod plate as shown. Slip 2 bolts through the chassis and pod. Then slip the 2 plastic spacers #5177 on the bolts and then one aluminum washer on each bolt.

Now slip the other 3 long bolts through the chassis.

Photo #96 - On the servo saver bolt, first slip an aluminum washer on, and then the #5176 servo saver spacer.

Next would be the large steel washer from the servo saver kit and the steel tube.

Now let's go back to photo #95. Slip the front end assembly, without the wheels on, and the servo saver, down over the 3 bolts.

Slip the other large steel washer over the servo saver and then add one aluminum washer as shown in photo #96.

Photo #95 - Your car should look like this now, except without the front tires on, or possibly without the muffler, too.

Now slip the radio tray down over the 5 bolts. Be careful, make sure everything clears.

If everything clears O.K., put an aluminum washer down over all 5 bolts, install and tighten the 5 lock nuts.

Install the front tires.

Now, from the large photo on the opposite page of the front end. Form the front anti-roll bar. Remember to have the 2 anti-roll bar mounts #5120, on the wire before you form it. Check the ends to make sure they're parallel to each other. Install the anti-roll bar. For competition racing, add a locking collar to each end of the anti-roll bar behind the "A" arm.

Shape the bumper with your coping saw to fit the particular body you're using.

BODIES - WINGS

There are 3 main types of bodies used in competition. Can-Am, which is also referred to as Sports Car. GT, which is also known as coupes. Formula I and/or Indy cars.

The Can Am bodies have been by far the most popular, because aerodynamically they create the most downforce over the entire body which greatly helps the car's handling by adding downward pressure to the tires, front and rear. The GT type bodies will be almost as good, but they give most of their downforce on the front of the body, and only a little on the rear. The Formula I or Indy bodies are by far the fastest in a straight line, but they also give the least amount of downforce and so are the poorest handling.

Associated makes many different types of bodies and each one makes a difference in the way the car handles. In the Can Am class the Ralt and Chevron bodies will have more rear end downforce than front end downforce, which will give the car less steering, also called understeer. This is very useful on slippery tracks, such as dusty or wet surfaces. The Porsche 30KL body adds a little more steering to the car and works well on average traction tracks, and would be considered a neutral steering body. It has an excellent balance between front and rear. The Elfin body gives the most nose downforce, which gives the car much more steering. This body is best used on high traction tracks. In the event of **extremely** high traction tracks, the Elfin body can be mounted 1/2" farther forward than normal, which should give you all the steering you'll ever need.

In the GT or Coupe class, the Corvette and Ligier Maserati handle as close to Can Am cars as any coupe can. Most of the other GT bodies have more front end downforce.

WINGS ARE VERY IMPORTANT.

They are used to adjust a precise amount of rear end downforce, so you can have the perfect amount of steering to get around the track **fast** and **consistent**. The **consistent** part is much more important than the **fast** but inconsistent driver.

Wings should be used with **all** bodies. There is only once in a great while where you'll be able to race on a track that has such great traction, that a wing will not be required. You may never find that track.

The wing can be adjusted to give a very small amount of downforce to the rear of the car, or a great amount. This can be varied by changing the wing location, up to 2", front to rear, and by changing the wing angle from 0 deg. to 30 deg. The farther toward the rear of the car that the wing is mounted, the more rear end traction you'll get. The greater the wing angle, the more downforce you'll get.

MOTORS - CARBURETORS

The motors we recommend for the RC500 car, are all 3.5cc size motors. These are Picco, K&B, OPS and OS Max. At this time it's hard to say which is the very best. Associated sells both Picco and K&B 3.5 motors, and all related parts and accessories. There are now many very good slide barrel type carbs available and Associated specializes in the McCoy and OPS types. Use silicon cement to install your carbs. A good air filter is a **must**. Glo plugs recommended for use are OPS, K&B, Fox and McCoy.

The most critical thing about your motor will be the type of fuel you use. **Most** model airplane fuels will destroy the R/C car. Oil with a lower temperature rating can be used in airplanes because of their greater cooling capacity on the motor. However, in R/C cars we need oils that will hold up under much higher operating temperatures.

We'll give you 2 choices on which fuels to use. First, if you're with other R/C car racers, ask around and see which is the most popular fuel that they're using. Ask if they have any problems with engines overheating or wearing out. If you feel confident what they're using is good, try it.

Your second choice. Use fuel that contains only castor oil and no synthetic oils. A castor oil based fuel will definitely work with no problems in your engine. A very good commercial fuel to use is K&B 1000. Now pay attention. K&B makes 2 types of 1000 fuel. One type with castor oil and another type with synthetic oil, which is called X2C. If the can of K&B 1000 fuel has an X2C on the label, **DO NOT USE IT**. Get the can that does not have an X2C on the label. **Do not** use K&B 500. All K&B 500 is synthetic oil. You obviously can use any other brand of fuel too that contains castor oil. Don't take anyone's word for what type of oil is in the fuel. You'd be amazed at how many people don't know one oil from another. Go by what's printed on the can label.

CARB and BRAKE LINKAGE

Refer to the large photos which will show the linkage installation. Turn the transmitter on and then turn the car switch on. Adjust the throttle lever or throttle trim on the transmitter so that neutral position is in the middle of the throw. The linkage will connect to the carb in different ways, depending on the carb. A popular connection is the Du-Bro ball link available in hobby stores. The rest of the linkage is in the kit and should be installed according to the photos. Set the throttle linkage so that with the throttle in neutral, and the carb closed, the locking collar on the wire on the forward side of the servo is 1/16" away from the white plastic throttle linkage mount #5180. The other locking collar on the spring, should be adjusted so the spring has enough tension to fully close the throttle.

Now, while the throttle is still in the neutral position install and adjust the brake linkage so that the brake spring is pulling the brakes on, a small amount, while turning both wheels forward together, at the same time. Turn both radios off.

STEERING LINKAGE

First, check the toe-in on the front wheels. Normally, you'll want both front wheels to point straight forward with no toe-in. Set the tie rods to this position.

Turn the radios back on. Set the steering linkage so that the wheels are pointing straight forward. Use the hole in the servo saver arm that will allow the front wheels to turn their maximum to the left and right. No more. Turn the radio off.

DIFFERENTIAL ADJUSTMENT

Release the brakes. Set the car flat down on a table. Now, with your thumb, try to rotate the chain and big sprocket forward. If the chain will rotate forward, but the 2 rear wheels **do not** move forward, then the diff is **too loose**. It **must** be tightened up. You'll adjust it by using the same piece of wire that you put in the Allen bolt head while you were assembling the diff.

Align the big hole in the #5360 left diff axle driver with the hole in the Allen bolt. Insert the piece of wire in the hole. Then turn the right hand wheel **forward** to **tighten** the diff. Only turn the tire a **small** amount forward, then **remove** the wire and check the diff again. When the diff is close to being set correctly, then you'll only want to move the tire about 1/8" at a time to adjust the diff.

If the diff is adjusted too loose you'll be able to hear it slipping in all the tight turns. If it's too tight the car will be closer to like a solid axle and harder to drive. If you continue to run the car with a loose diff, you will flatten the balls in the diff from too much sliding, instead of rolling, and then you'll have to replace the balls.

STARTING THE CAR

You'll need a 1 1/2 volt dry battery and a glow plug clip, both available from your hobby store, as well as a fuel bulb and some medium size silicon fuel line tubing, which you connect to your carb and muffler from the fuel tank as shown. The muffler shown in the photos is a McCoy, MC 47M, connecting to a K&B header pipe by McCoy #MC48F. There are many good mufflers available. Mount the muffler so the outlet points up through the top of the body. You'll have to cut a hole in the body at that point, but it will keep the car a lot cleaner.

Associated sells a #SP25 which is a Sullivan hand starter. Along with this is needed a hard rubber donut #SP26. Incidentally, this hard rubber donut can be easily installed on the starter by turning the rubber donut inside out. Then with the rubber donut inside out, hold it up against the starter wheel and flip the rubber donut out over the wheel.

Now let's start the car. The carb should be set so that in the closed position, it will actually be about .020 open. If it's completely closed, the car will not idle. The high speed fuel adjustment should be about 2 turns open, as a starting point.

Using the fuel bulb, fill the tank with fuel. Turn the transmitter and car radios on. Connect the glo plug wire to the glo plug. Turn the starter motor on and see if viewing the starter donut from the position you'll be holding the starter to start the car, that the donut will be turning in the same direction as the car's tire in going forward.

Now listen carefully. Stand on the right hand side of the car. Hold the starter in your right hand. With your left hand, hold the right side rear tire, by placing your thumb inside the wheel and holding the tire. Now turn the starting motor on and hold it **very tightly** up against the flywheel from the bottom side. You'll have to tilt the car up slightly. This will turn the motor over and in about 10 to 15 seconds it should start up. You might have a friend help by opening and closing the throttle with one second intervals.

Some new motors are very tight and if you're having trouble turning the flywheel over, then you can loosen the glo plug and that will relieve some compression, making the motor easier to turn over. Once the motor has started, re-tighten the glo plug. Remember, the flywheel should be turning in the opposite direction that the tires turn going forward.

Once you've got the motor running it should be running very rich. If it's too rich to drive the car, lean it down about a 1/4 turn and see if you can now drive it. You want to drive it a little on the rich side till you get it broken in. Once you've got it so it keeps running then make smaller carb adjustments per the carb manufacturer, until it comes off of the 4 cycle rich setting, to a constant 2 cycle. Never try to run too lean. You won't go any faster. You'll only overheat the motor and burn out the motor.

WINNING RACES

Drivers win races for a **combination** of reasons. Not just because they're good drivers, but because they're good drivers with a good car, with a correctly tuned engine and **most important**, a **correctly assembled and tuned car**.

To win a race a **combination** of things must be right. To lose a race, only **one** thing has to go wrong.

You'll find that the more you drive, the better you'll become as a driver - **automatically**. The key to getting the car to work perfectly on your track is experimenting. It would be a good idea to have a small notebook, and then as you make changes in anything, write them down for reference. It's asking too much to remember everything without notes.

There is a very large **combination** of things to tune on the car. Body, wing, gears, clutch, tires, carb, shocks, springs, anti-roll bar, toe-in, camber, ride height, differential, brakes, etc. and they all must work together in a perfect **combination**. A brake that doesn't release soon enough, can make the clutch work too hard, creating too much heat, is a good example.

Associated only makes one type of rear tire. This is the best traction compound tire we have ever found. On the front there are 3 different tire sets available. Sponge rubber, which come in the kit, and is very useful in learning to drive the car. Replacement front rubber comes in the form of a molded rubber. There are 2 hardnesses available. The standard hardness, which is good on average traction tracks, and wears the longest. Then there is a soft molded front tire, which gives more steering, but it will also wear out faster.

You should also balance the front wheels and tires. Turn the front tires slowly and watch them stop rolling on the ball bearings. The heavy side will naturally go to the bottom. Place a small 3/4" long wire nail into the inside of the tire, right next to the wheel. You might need 2, 3 or more nails. Keep spinning the tires, and installing nails until the tires are balanced.

The clutch bells are solid, without air cooling holes, for areas that have to race in the rain. However, if you only race in the dry, then you can lighten the clutch shoes, by cutting 1/16" off of their length at a time, until the engine seems to be accelerating faster. This will cause more clutch heat, so then you will have to cut away about 50% of the flat side wall of the clutch bell, between the gear and the outer diameter. Make 4 cutouts to do this. The bell should also be balanced. This allows a lot of cooling air into the clutch, to get rid of the added clutch heat.

The correct chassis "**tweak**" is very important to having an excellent handling car. A chassis that is incorrectly set is called "tweaked". This condition will make the car have more steering in one direction than the other. It will also make the car unstable coming out of corners under power.

A tweaked chassis is one that has one of its front tires pushing down on the ground harder than the other front tire. This causes the chassis to be "loaded" to one side making the car unstable.

To set the car flat, with no tweak, a tweak board must be used. With the RC500 both the front and rear must be set. A very easy way to do this, is to set the chassis on the tweak plate with the front tires on the bubble bar. Slip a piece of

3/4" round rod or board under the pod plate to raise the rear tires off of the tweak board. Now you will be setting the front end flat with the power pod.

Adjust the front end tweak flat, by either shortening the shock spring a small amount by cutting the spring, or lengthen the spring area by installing small washers in the spring "cups".

After the front end is set, remove the round rod from under the pod, and rotate the car around so the rear end is now on the bubble bar and adjust the rear end. Make sure the shocks are moving freely when you're checking the tweak.

To make setting the tweak a lot easier and faster Associated has an optional item called spring adjusting collars, part #5134, which simply slide up and down on the shocks and can lock in place easily. Another optional item is some nylon bushings for the ends of the shocks which replace the rubber grommets making for a more positive shock action. This is part #5135.

For those of you that want to go all out racing, Associated has a Custom Racing Shock designed for racing. This shock is far ahead of anything else available now. It's used by Team Associated. Part #5136.

Remember, the key to going fast is in doing a **combination** of things better than the guy you're racing against. And to be first in a race, first you must finish a race. Make your car as reliable as possible.

Good luck in your racing.

GEAR RATIO CHART ONLY applies to RC500

13 - 42	6.46
13 - 43	6.62
13 - 44	6.77
14 - 42	6.00
14 - 43	6.14
14 - 44	6.29
15 - 42	5.60
15 - 43	5.73
15 - 44	5.87
16 - 42	5.25
16 - 43	5.38
16 - 44	5.50

Remember, the above is a gear drive chart, which includes the 50% reduction of the chain drive.

The **final drive ratio** includes the gear ratio, plus the rear tire diameter which affects engine RPM.

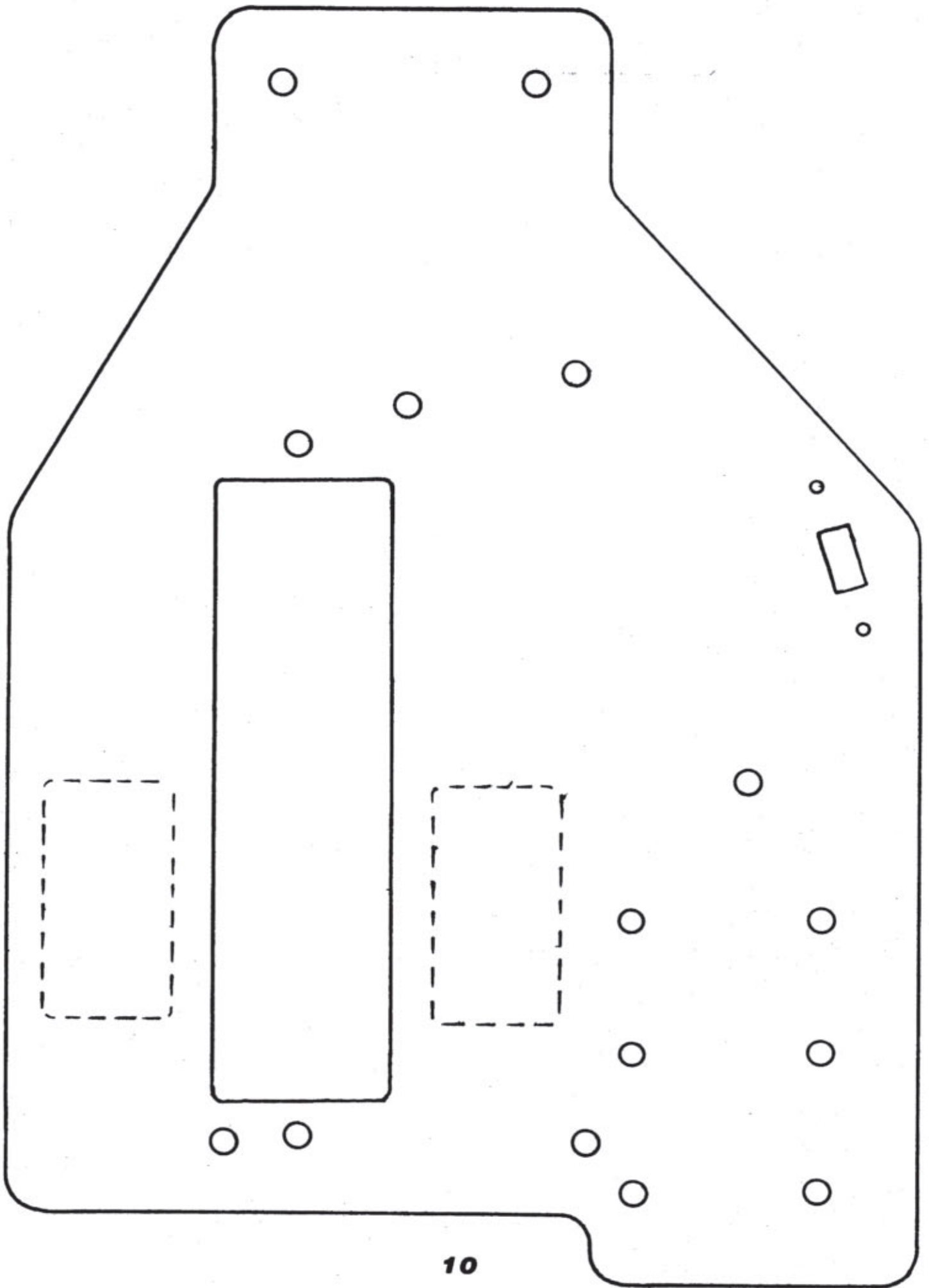

RC 300 RC 200 SERVO SAVER 2525

TIE ROD ASSEMBLY 2530

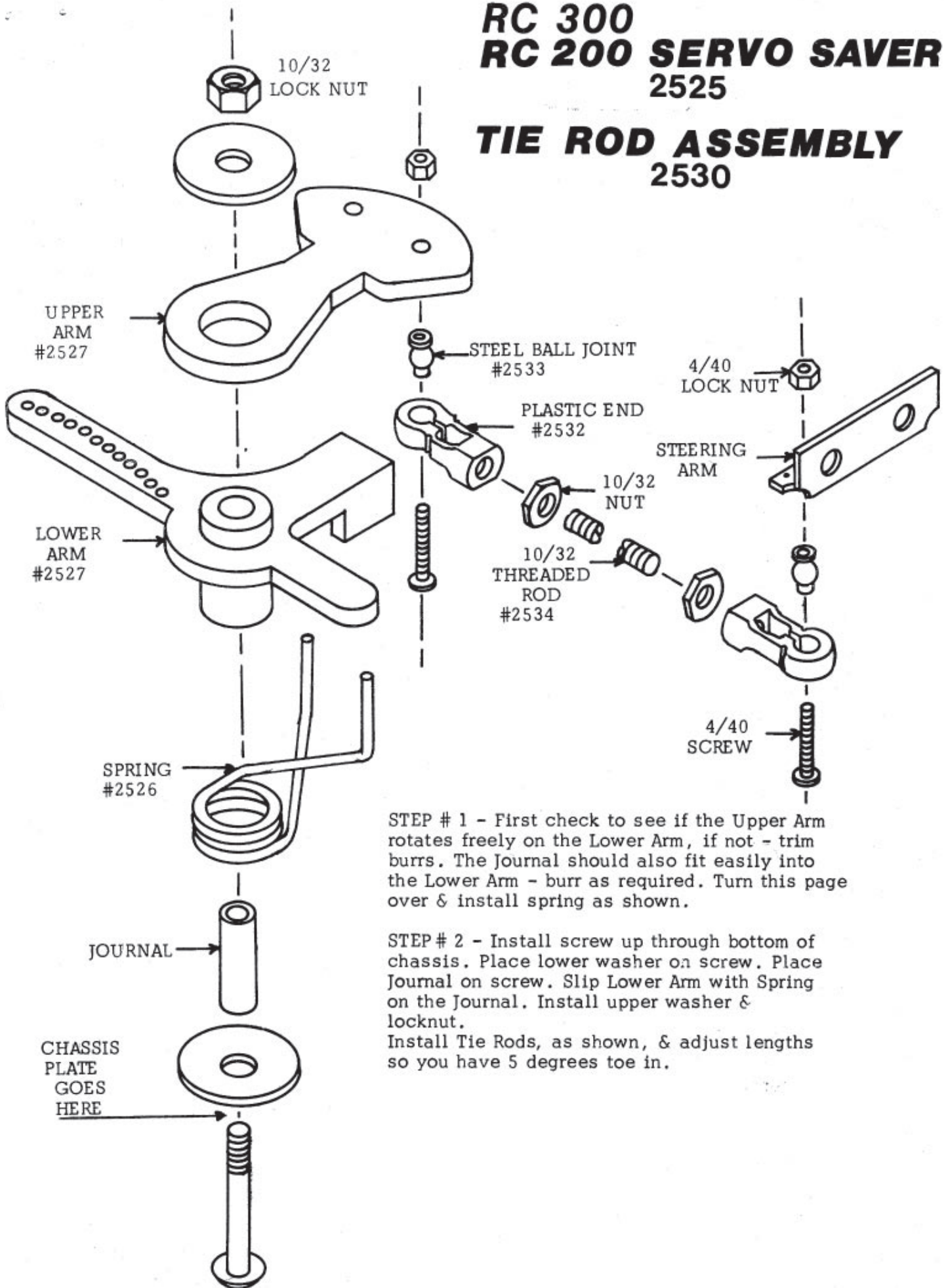

STEP # 1 - First check to see if the Upper Arm rotates freely on the Lower Arm, if not - trim burrs. The Journal should also fit easily into the Lower Arm - burr as required. Turn this page over & install spring as shown.

STEP # 2 - Install screw up through bottom of chassis. Place lower washer on screw. Place Journal on screw. Slip Lower Arm with Spring on the Journal. Install upper washer & locknut. Install Tie Rods, as shown, & adjust lengths so you have 5 degrees toe in.

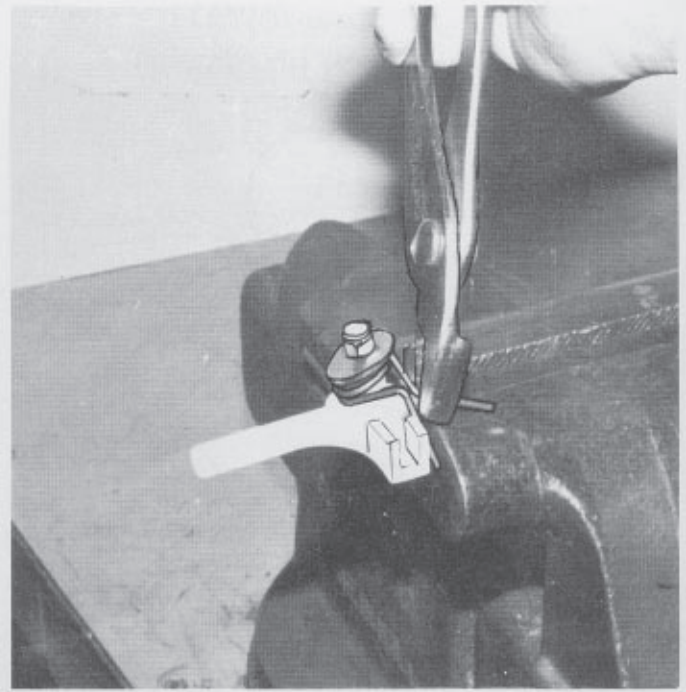
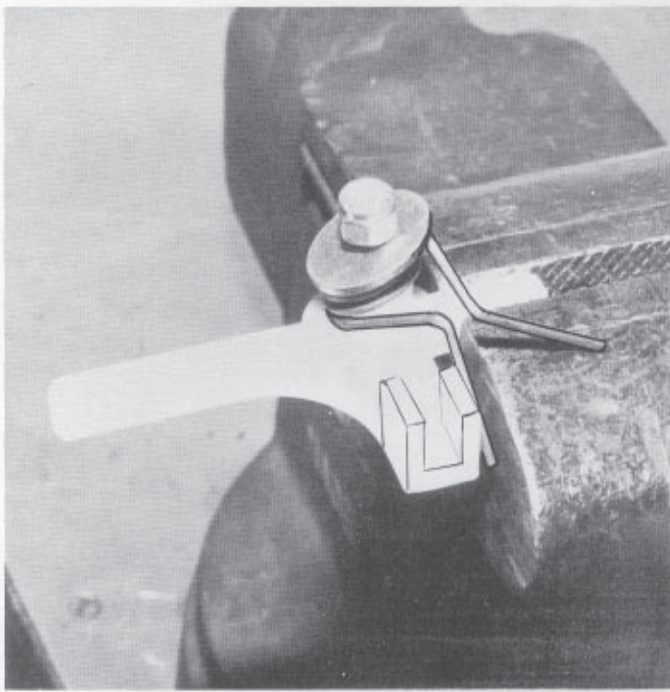

#1 The easiest way to install the spring on the Lower Arm is as shown. First - install the Servo Saver mounting screw in the TOP of the Arm, then turn the arm upside - down. Next - slip the spring on, to the right. Next - DO NOT put the Journal on, but put one Washer on & put the Nut on. ONLY tighten the Nut about 3 turns - NO more. IT MUST BE LOOSE.

#2 The BEST way to install the Spring, is to hold the short part of the Lower Arm in a vise, as shown in photos #1 & #2. Using a pliers, take hold of the spring leg - to your right - lift it up & cross it over the Saver center to your left side.

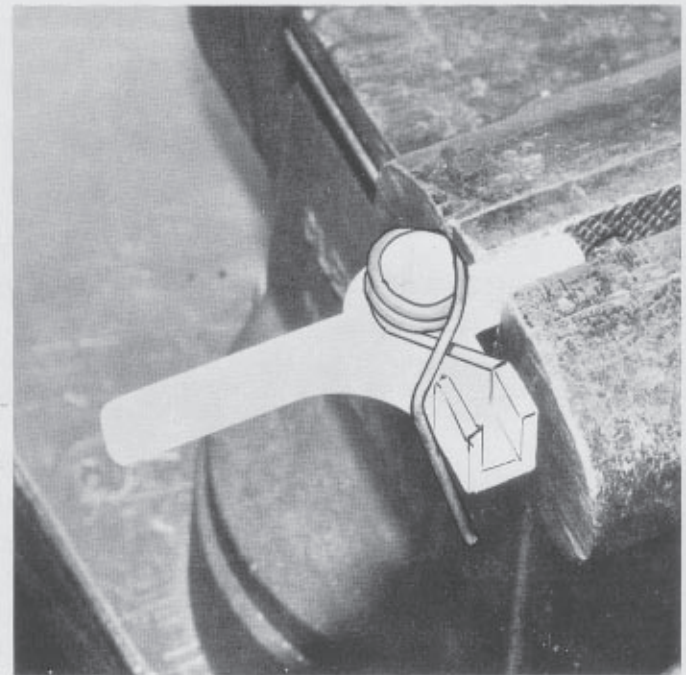
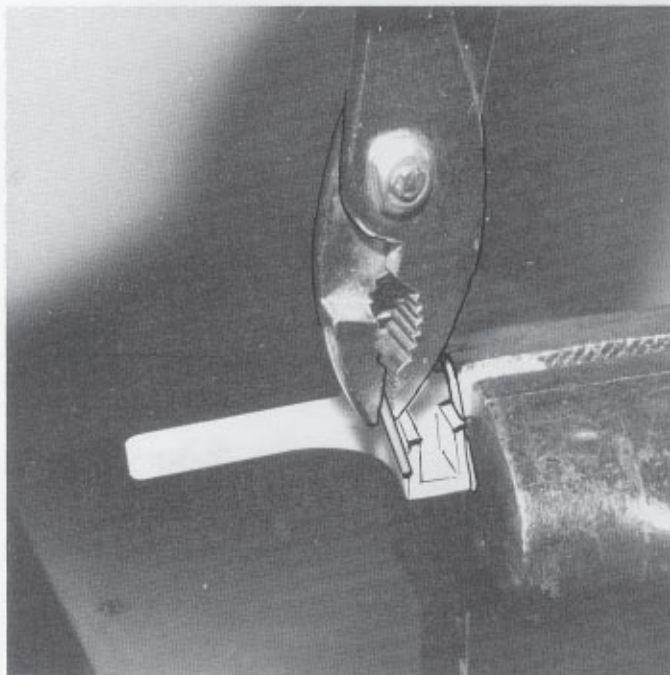

#3 Keep your fingers away from the spring, until you have completed moving the spring to your left side.

#4 When you have the spring crossed over, push the coil down. The spring will now stay in place. Remove the nut, washer & screw. Assemble the Servo Saver per STEP #2 on the other side.

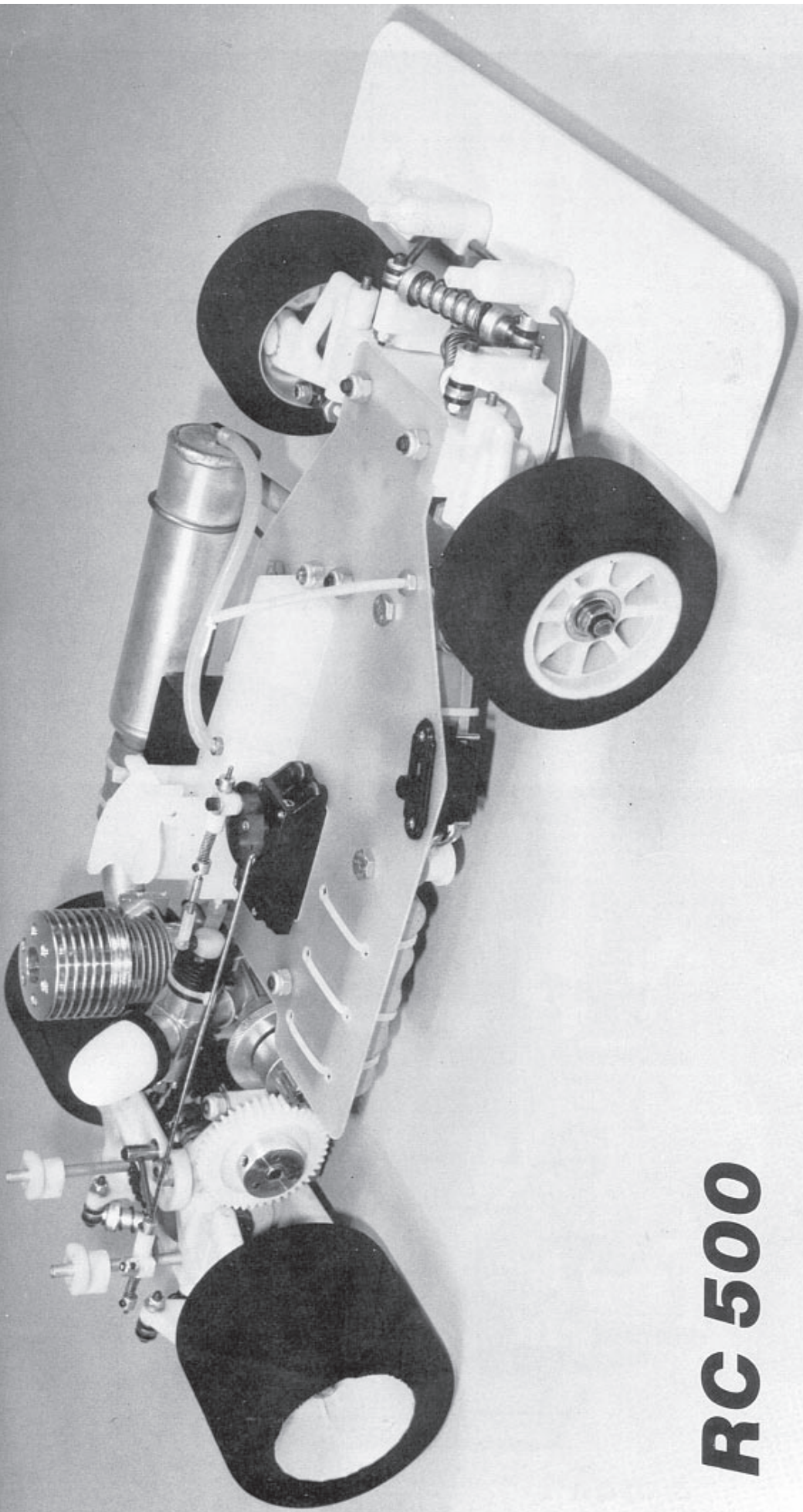

RC 500

RTA TEAM ASSOCIATED 

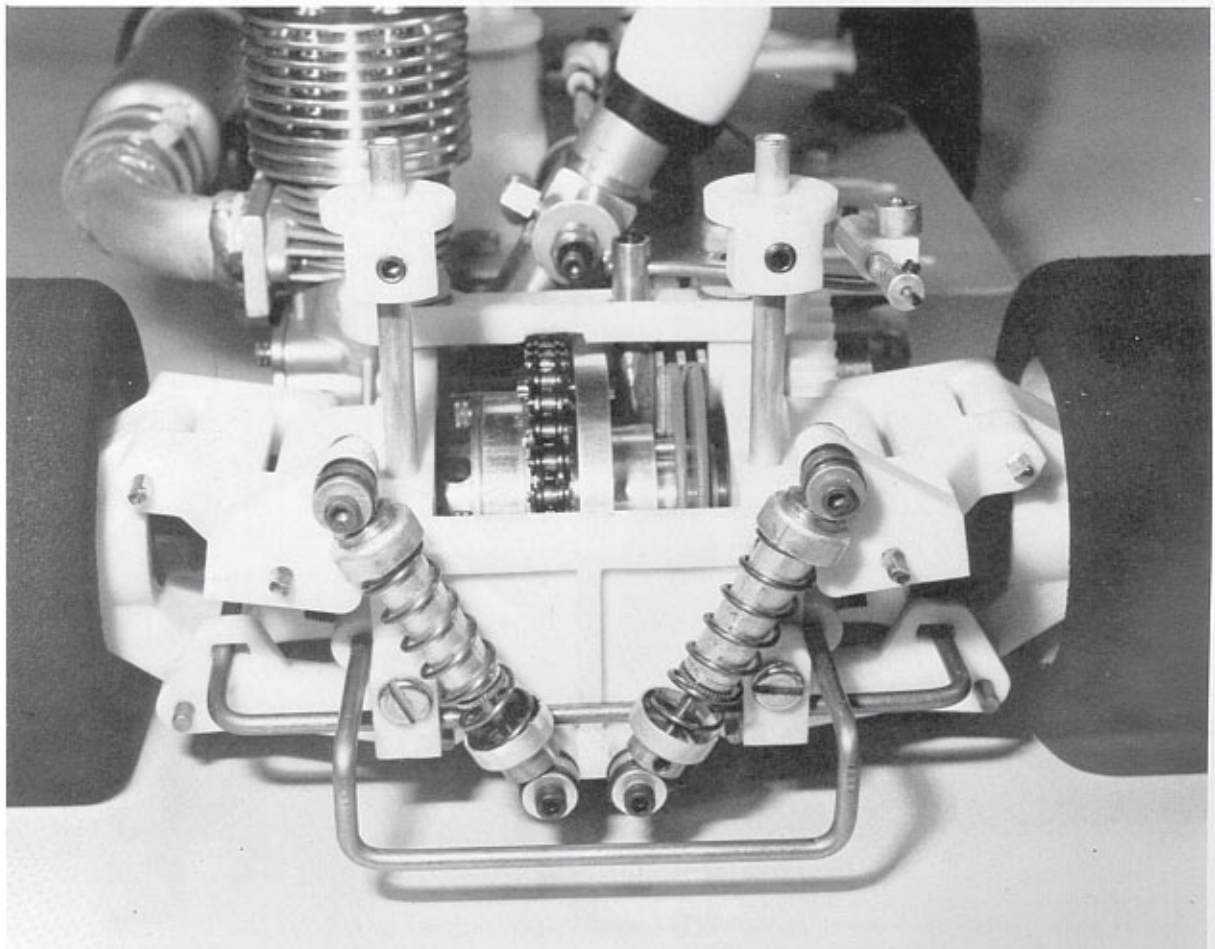
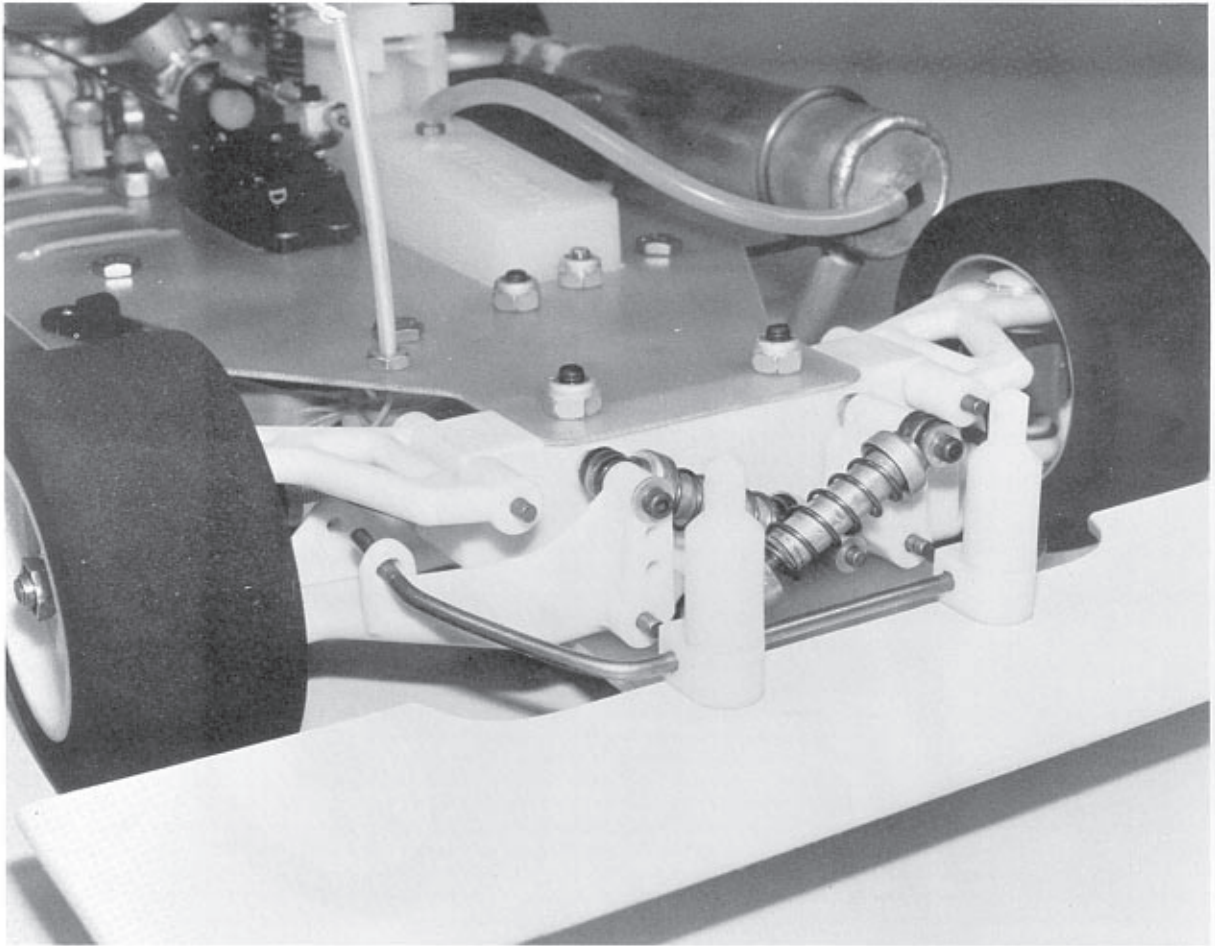

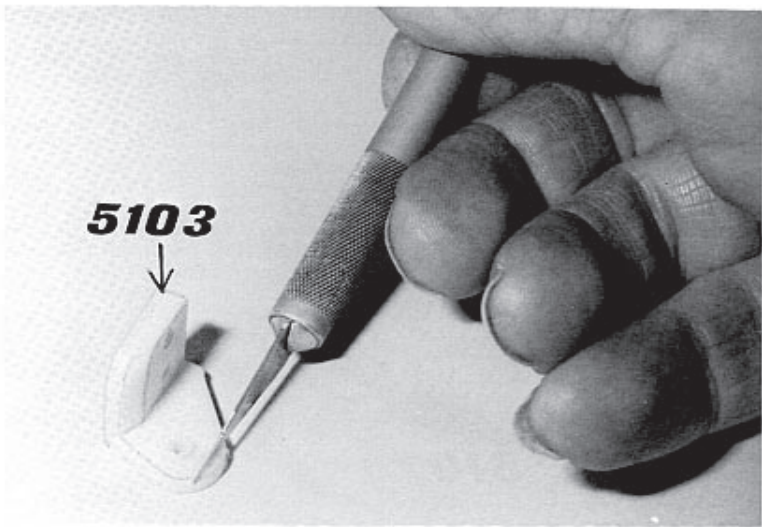

Photo 1

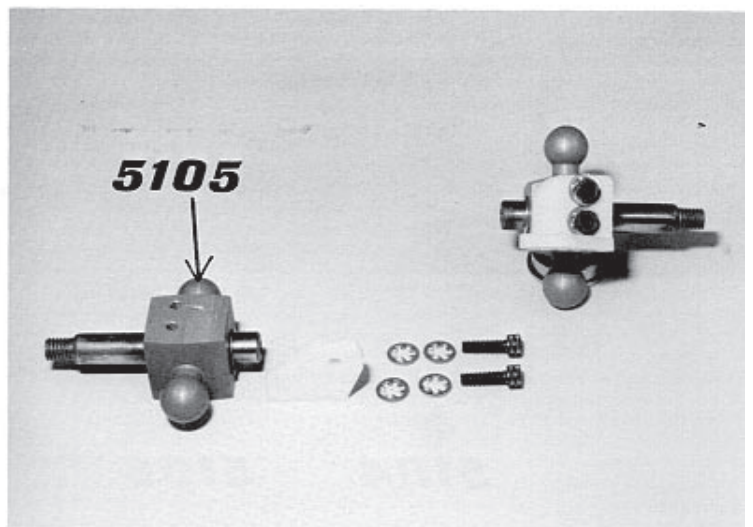

Photo 2

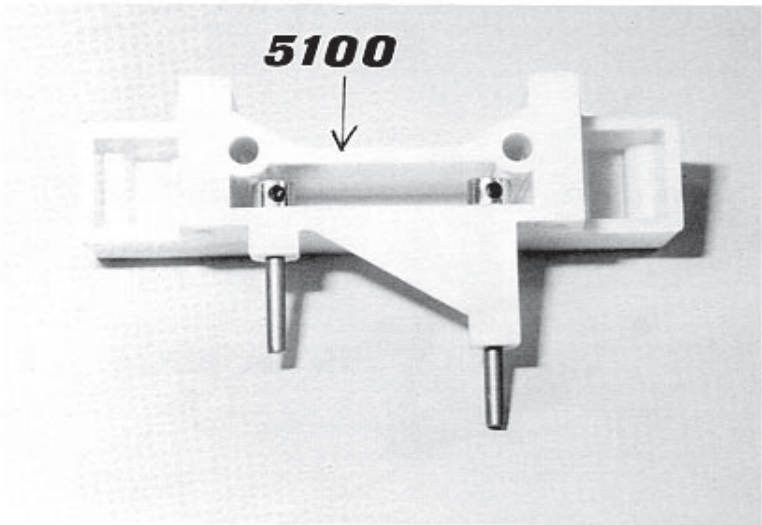

Photo 3

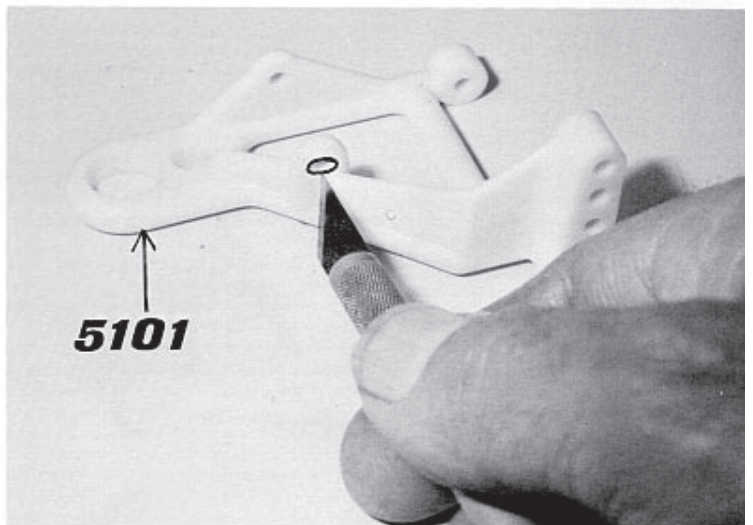

Photo 4

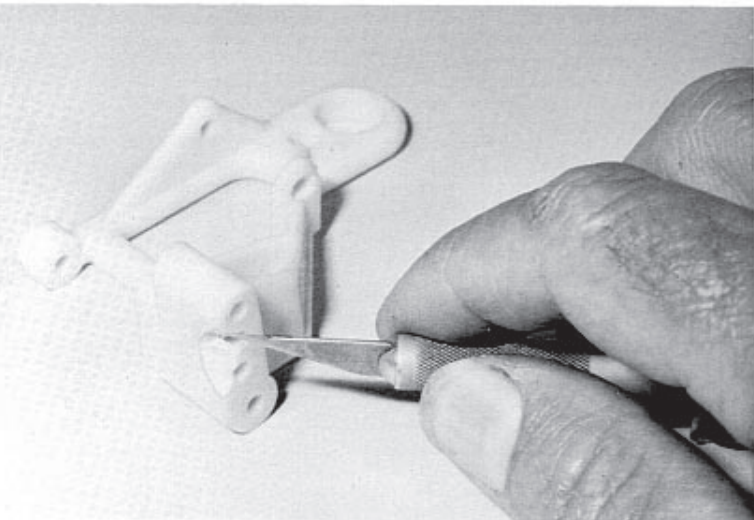

Photo 5

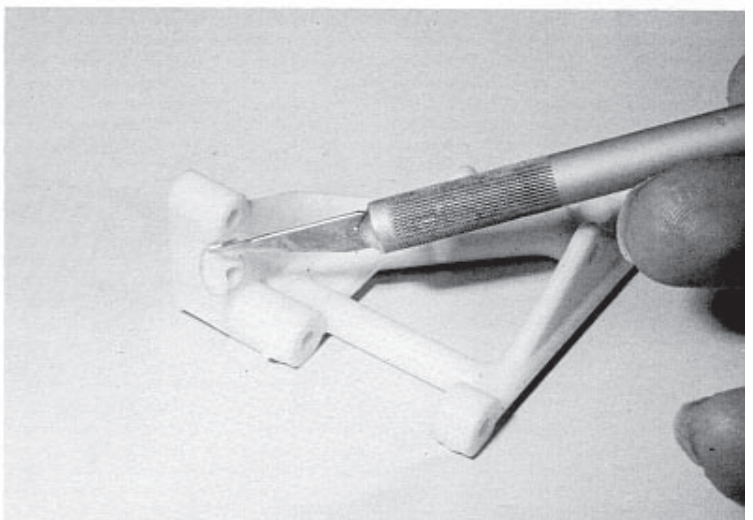
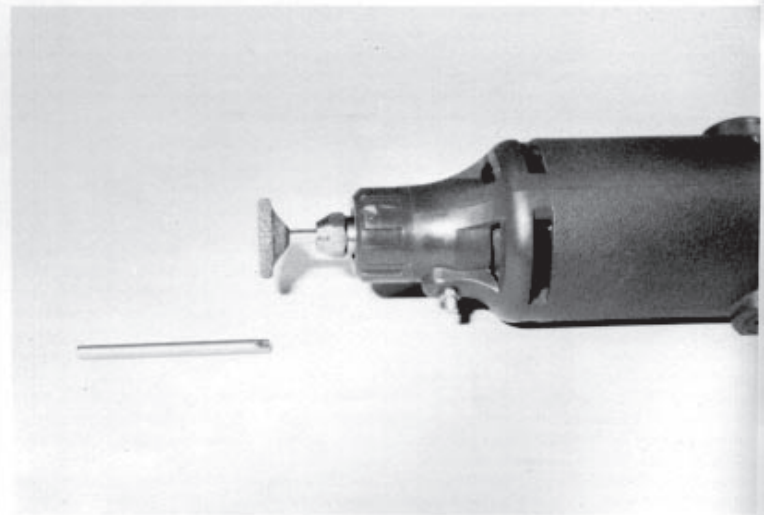
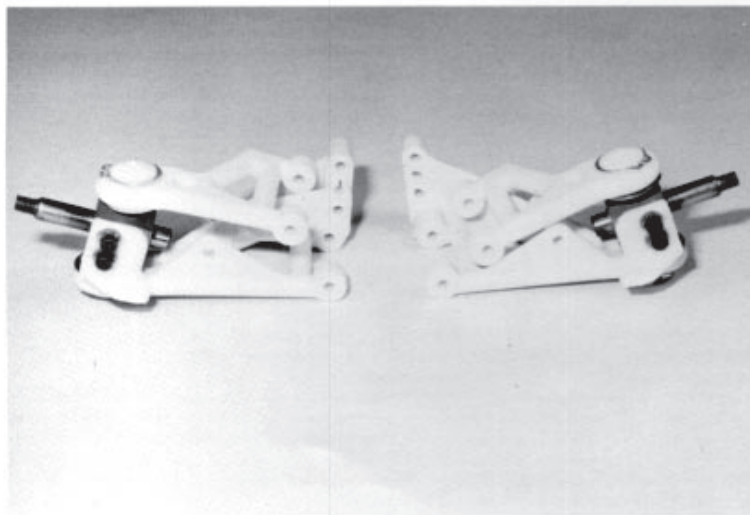
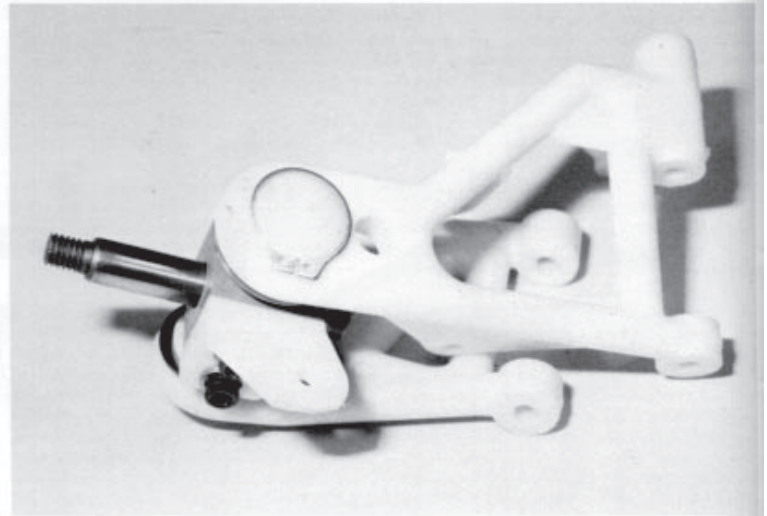
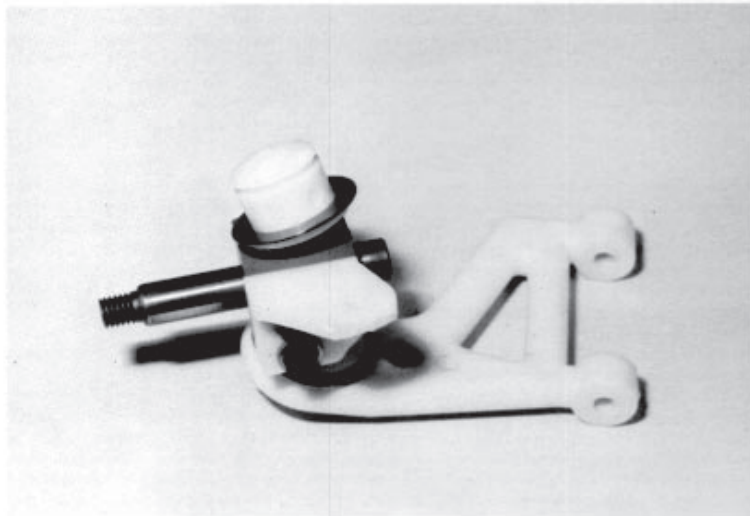
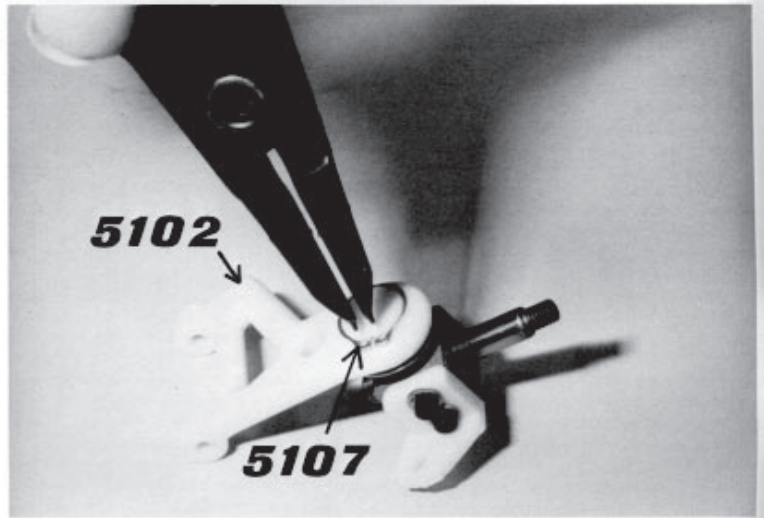
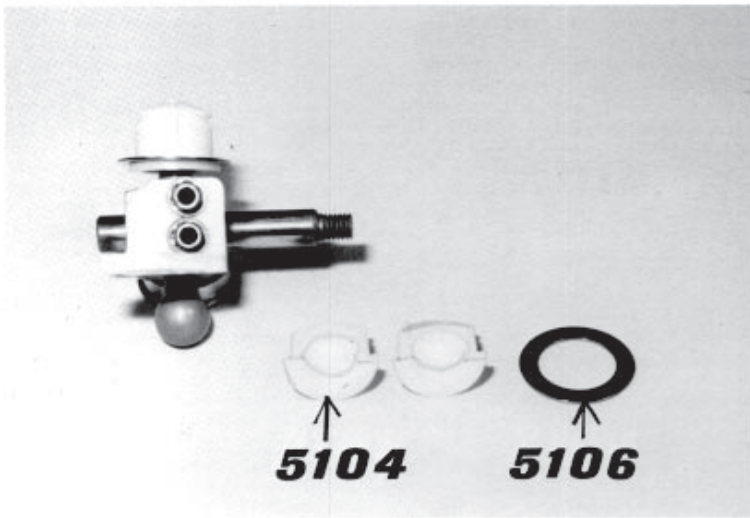
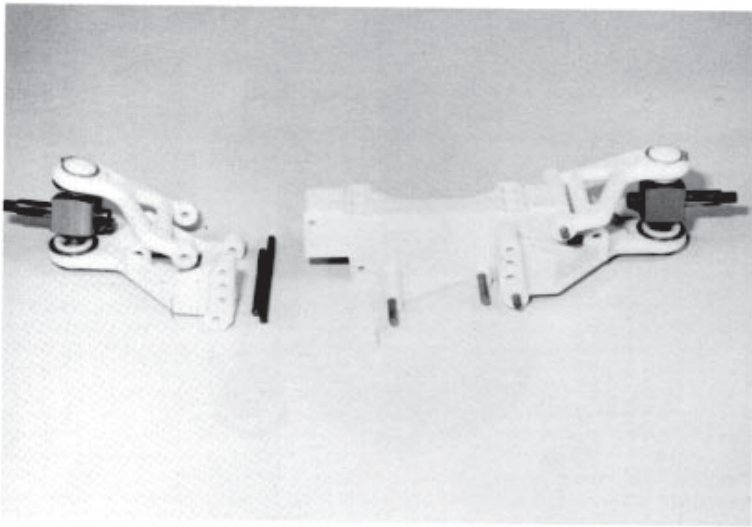
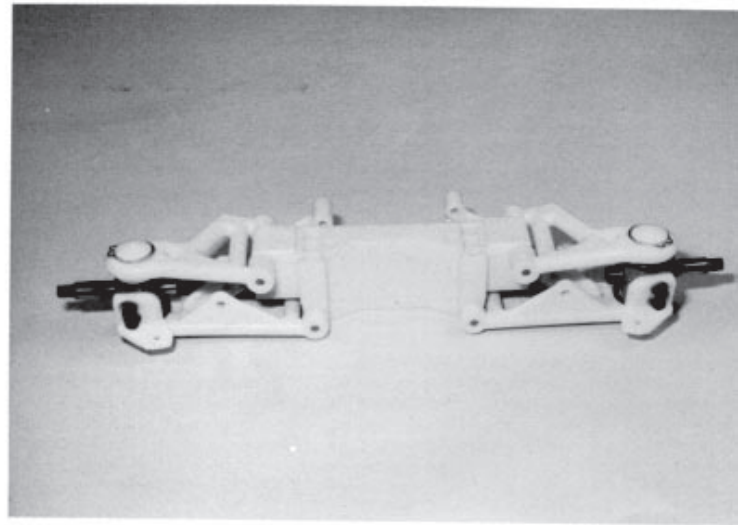

Photo 6





13



14

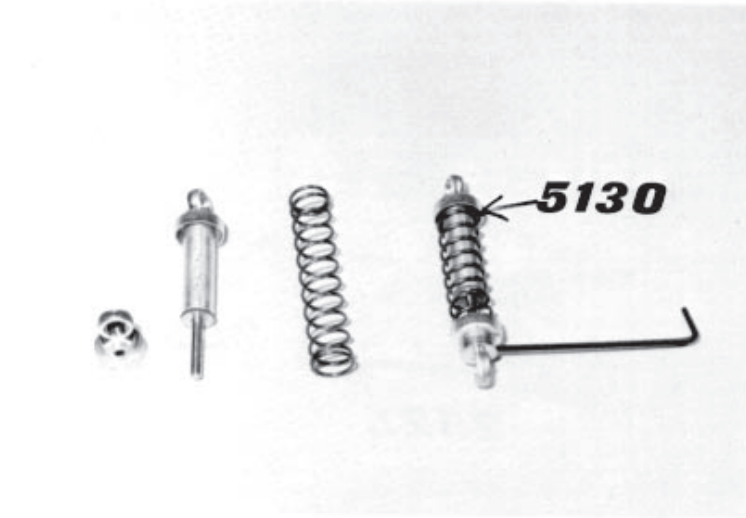

15

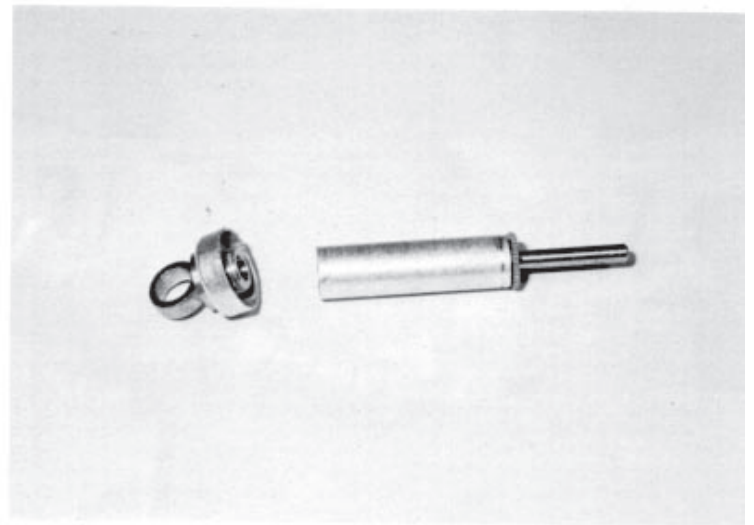

16



17

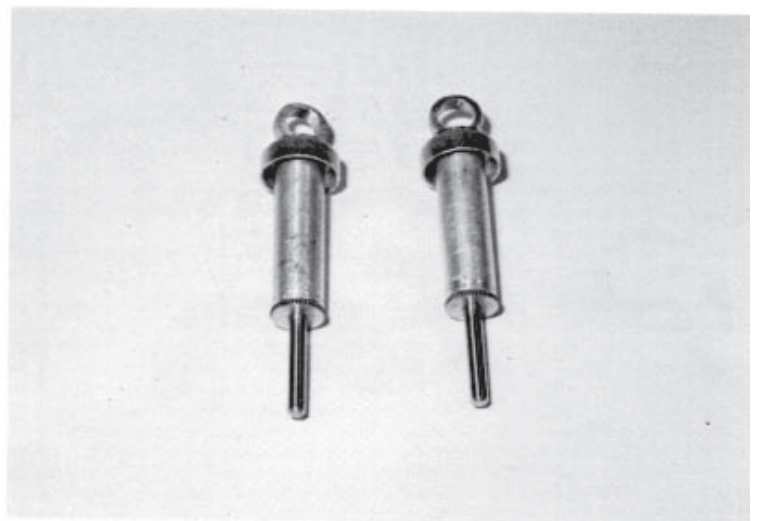

18

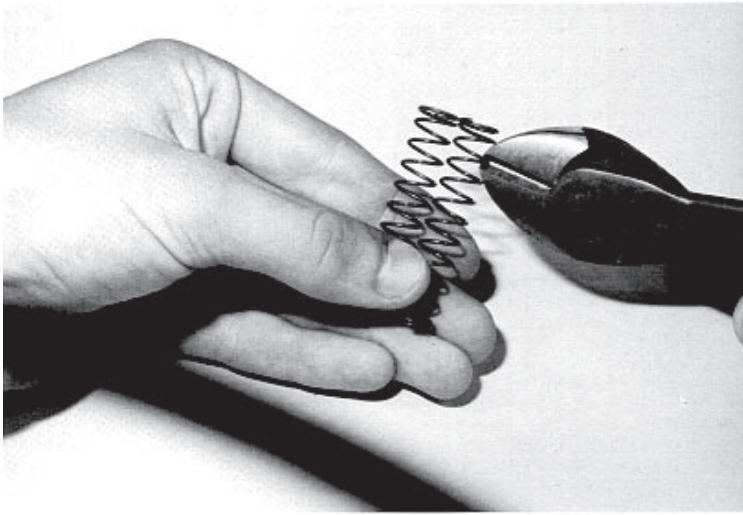

19



20

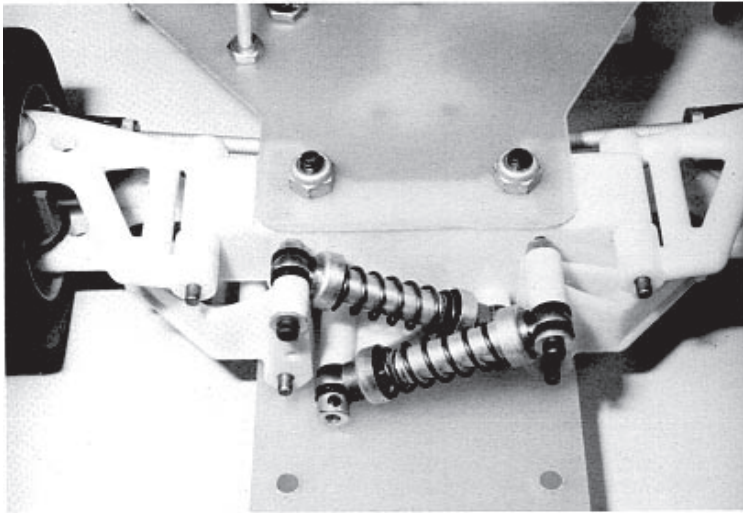

21

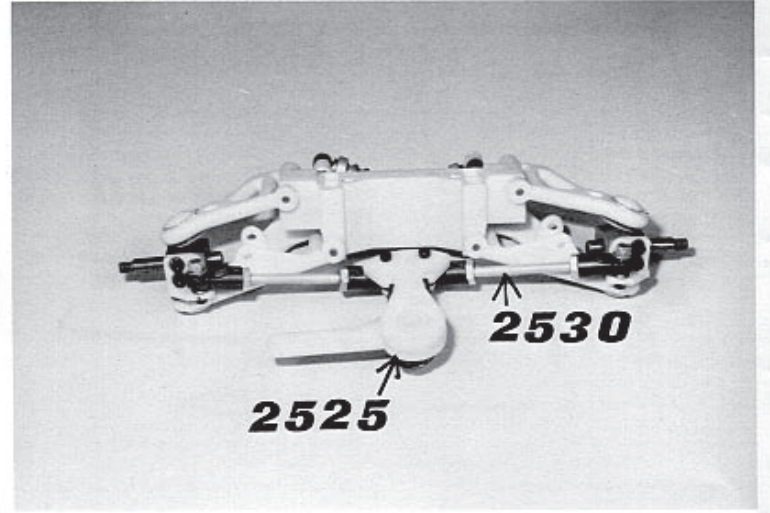

22

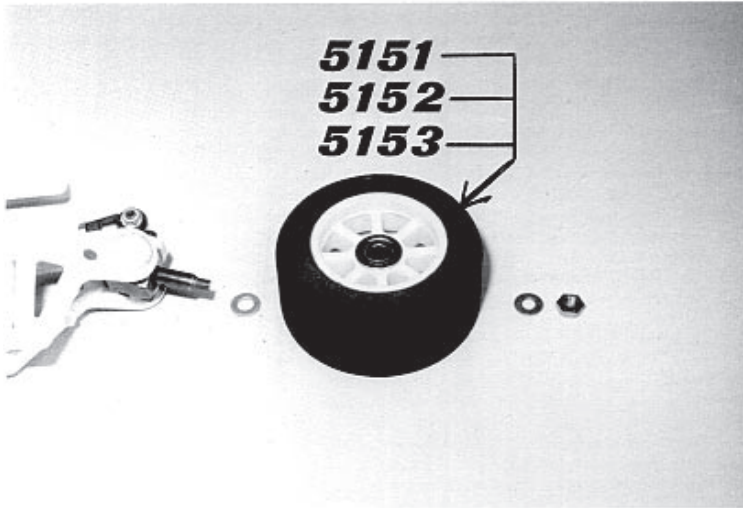

23

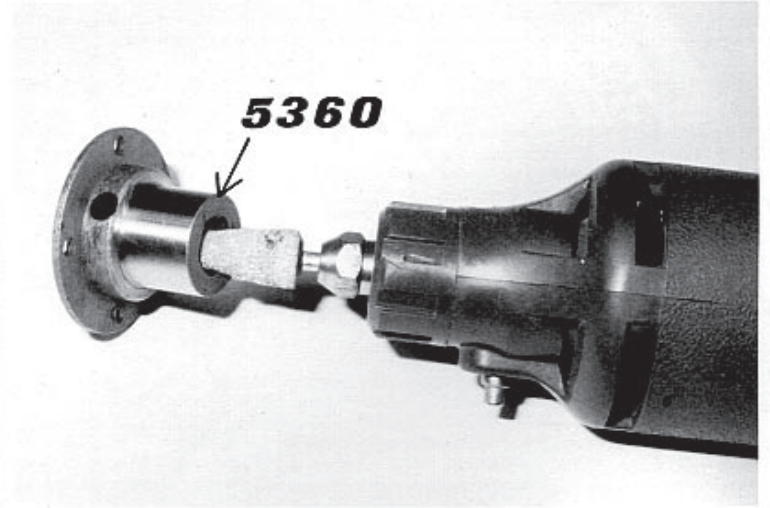

24



25

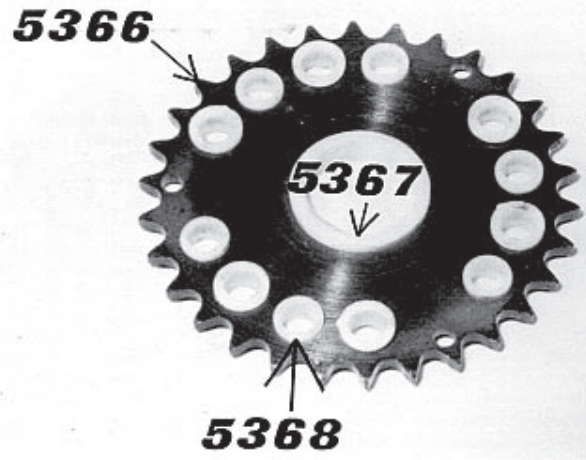

26

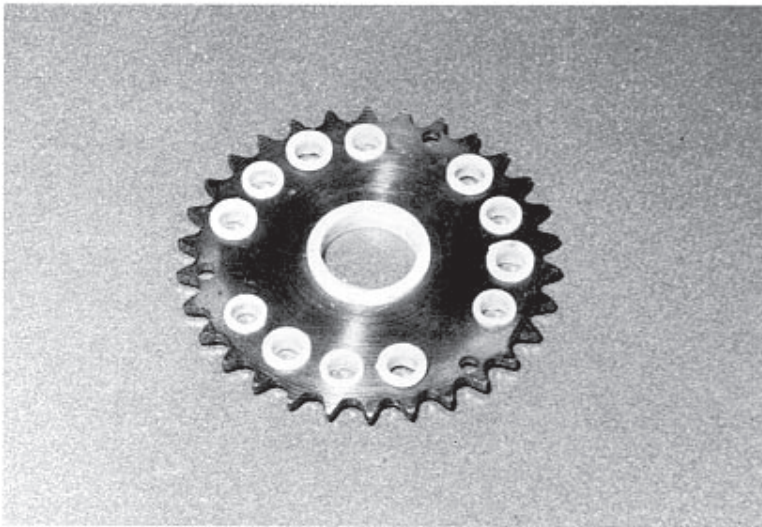

27

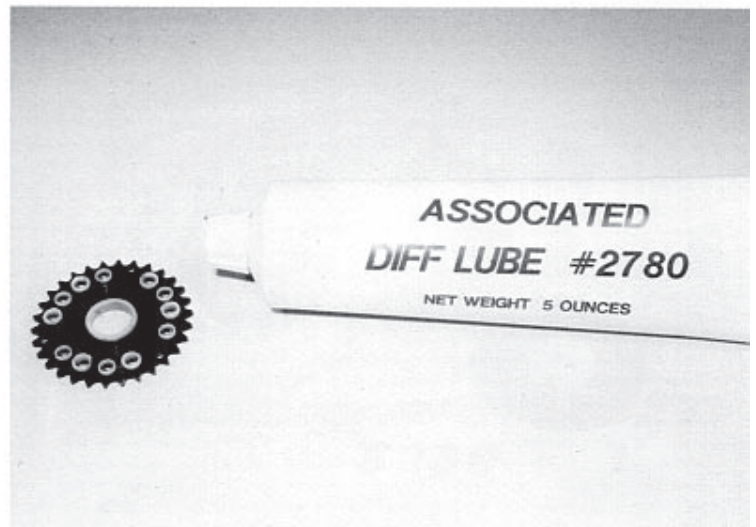

28

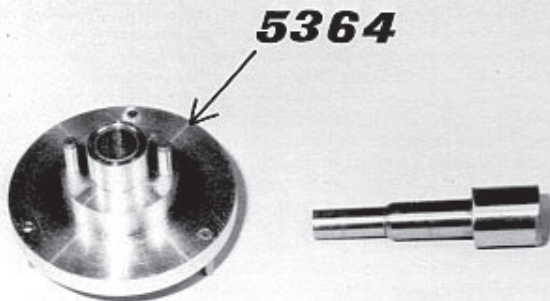

29

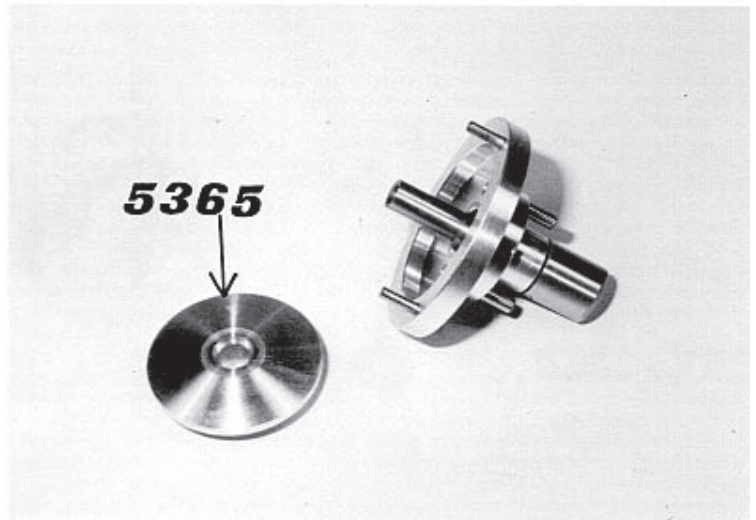

30

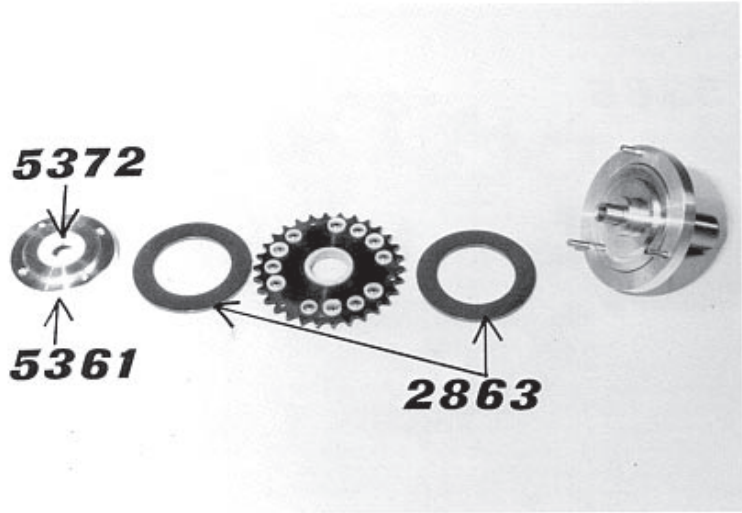

31

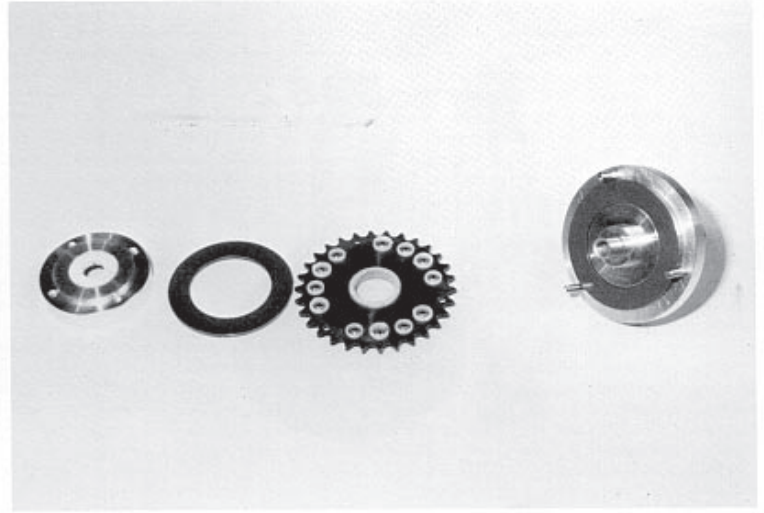

32

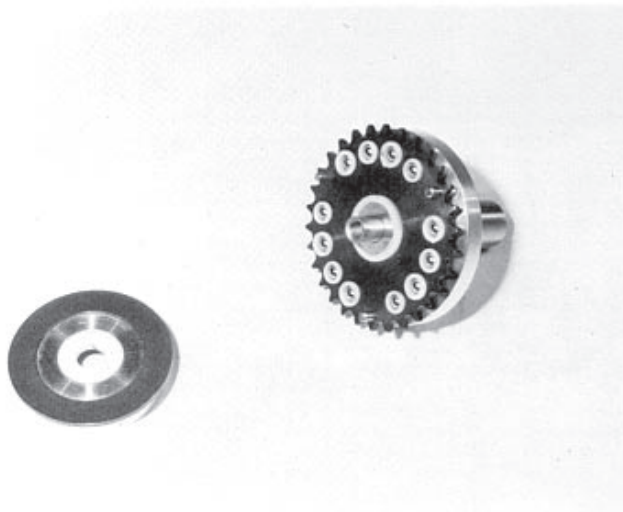

33

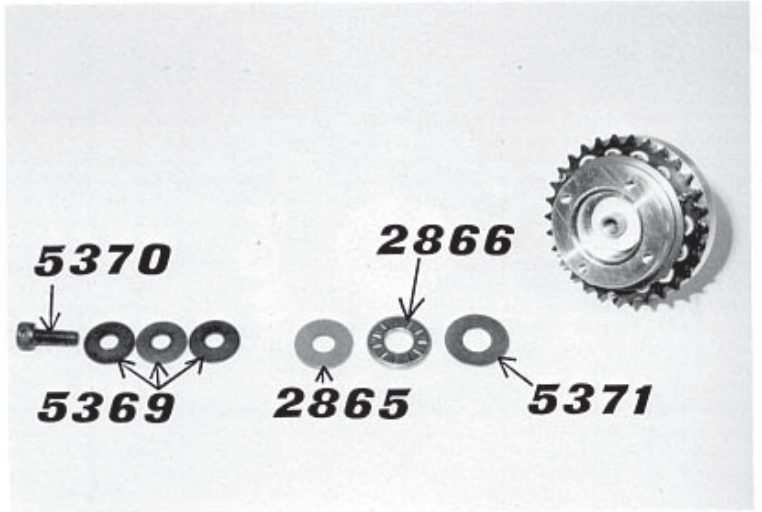

34

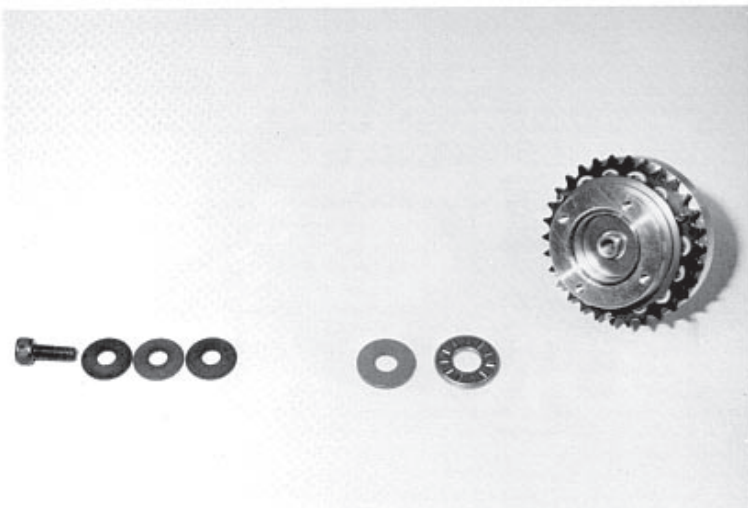

35

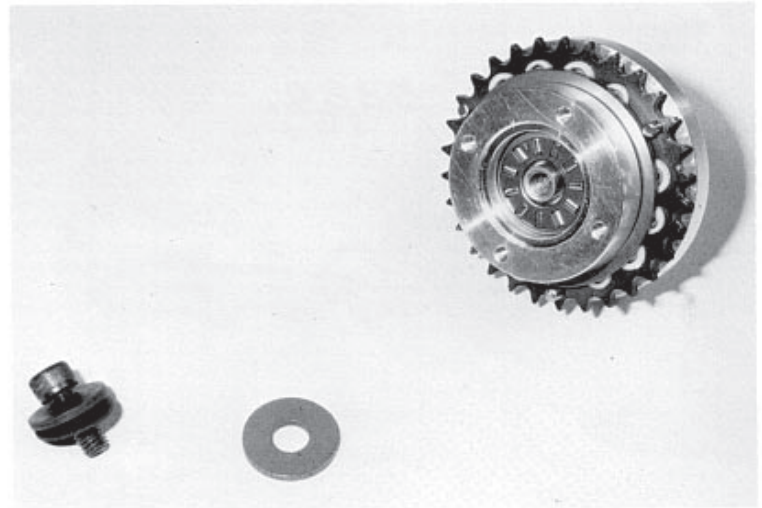

36

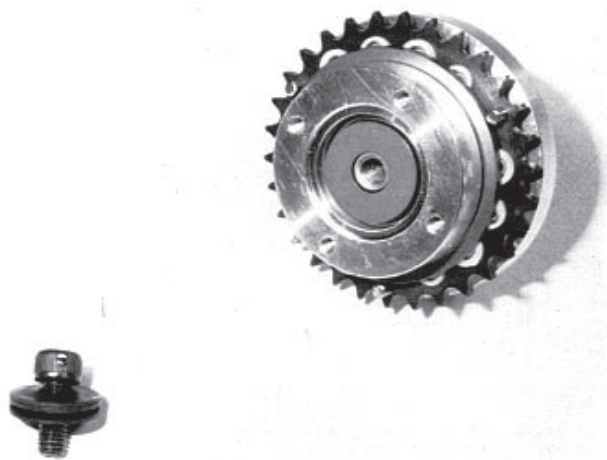

37

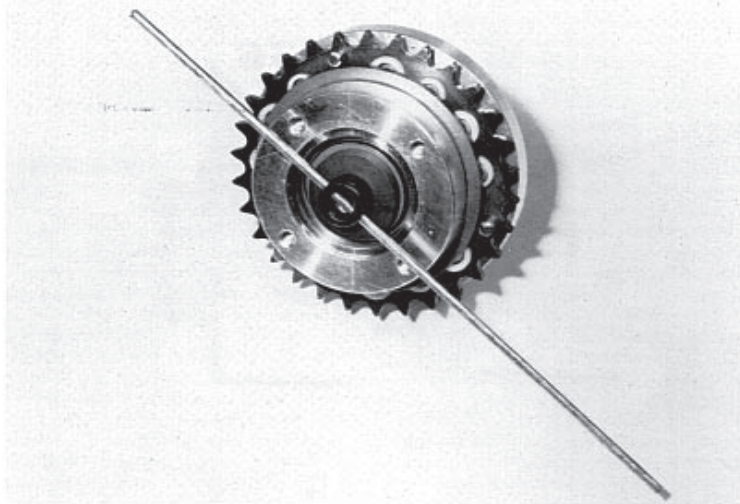

38

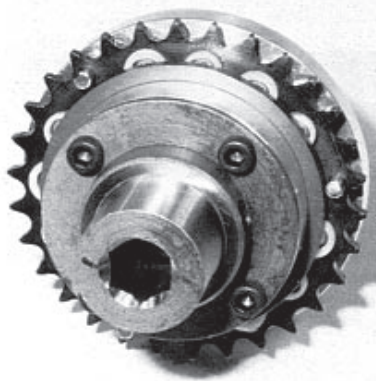

39

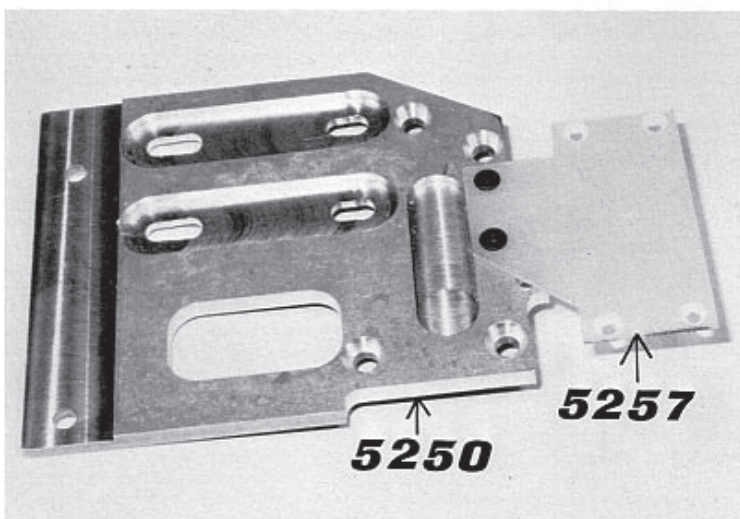

40

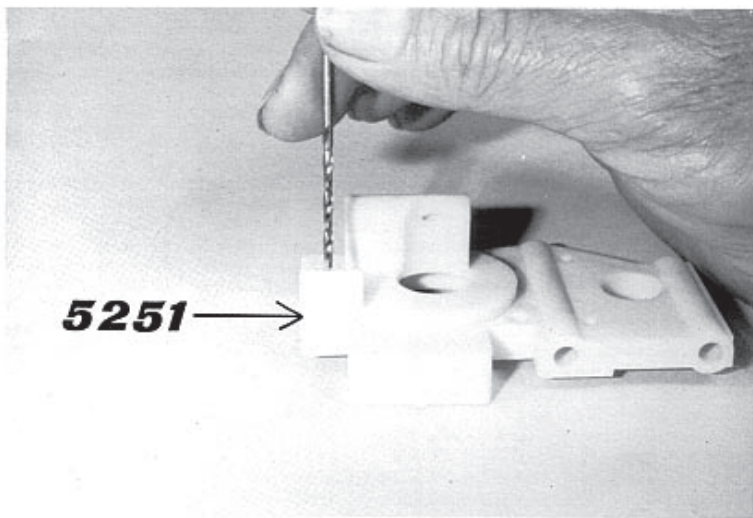

41

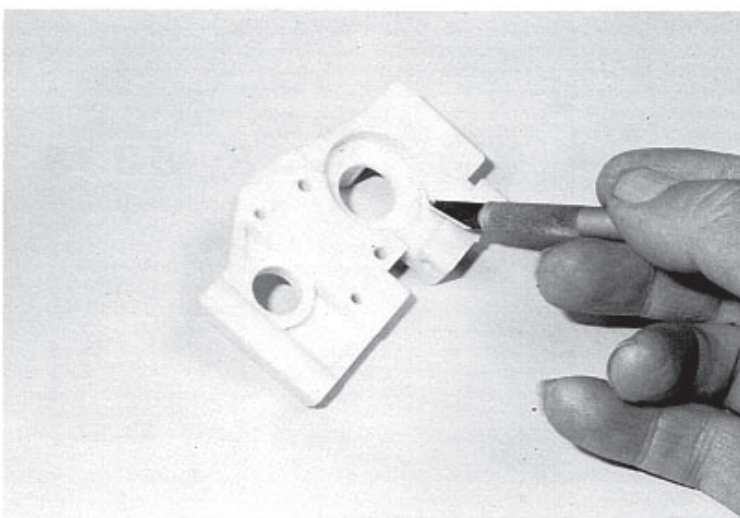

42

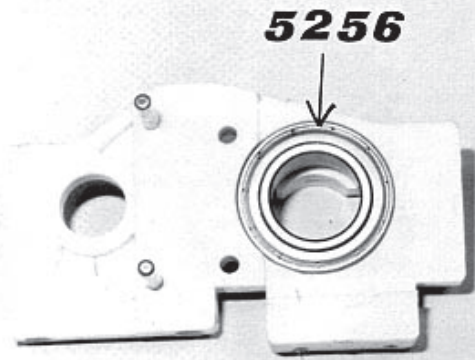

43

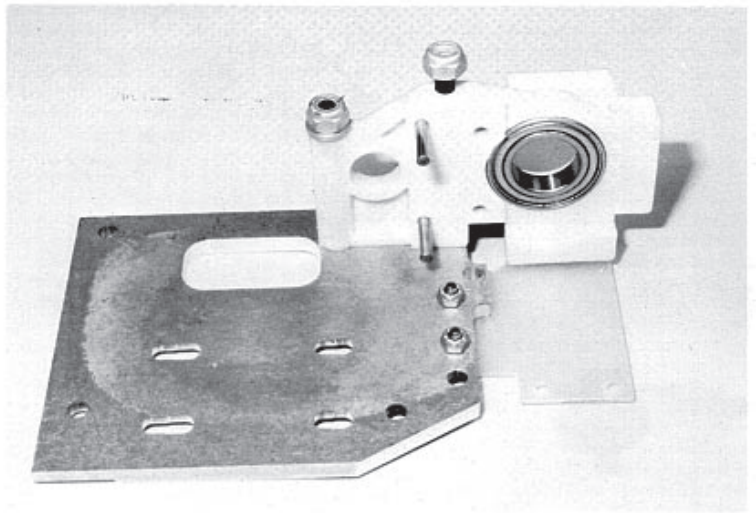

44

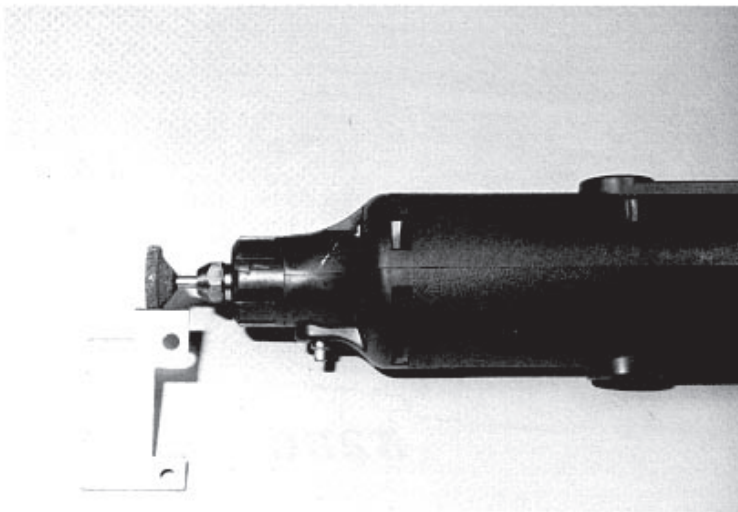

45

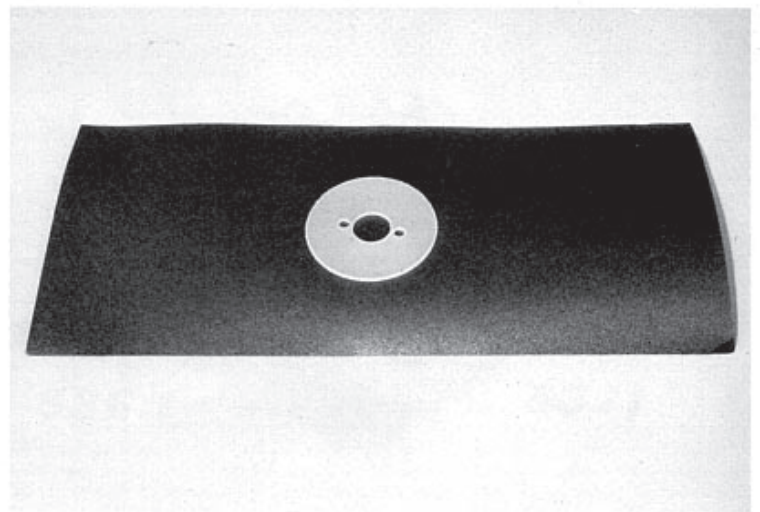

46

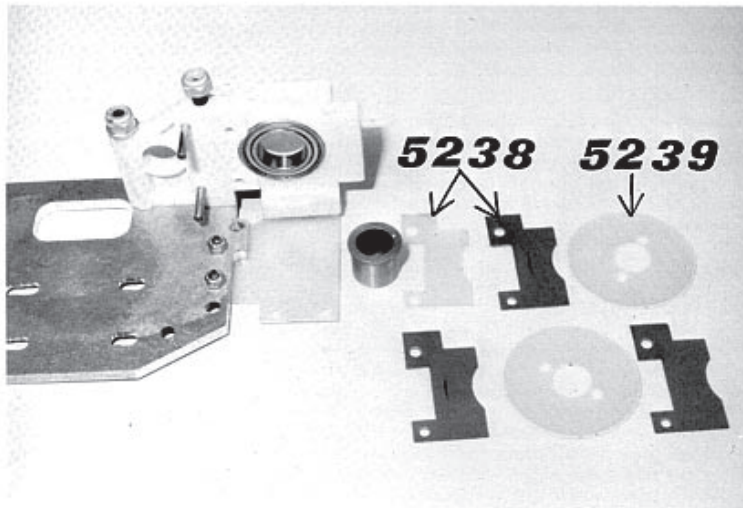

47

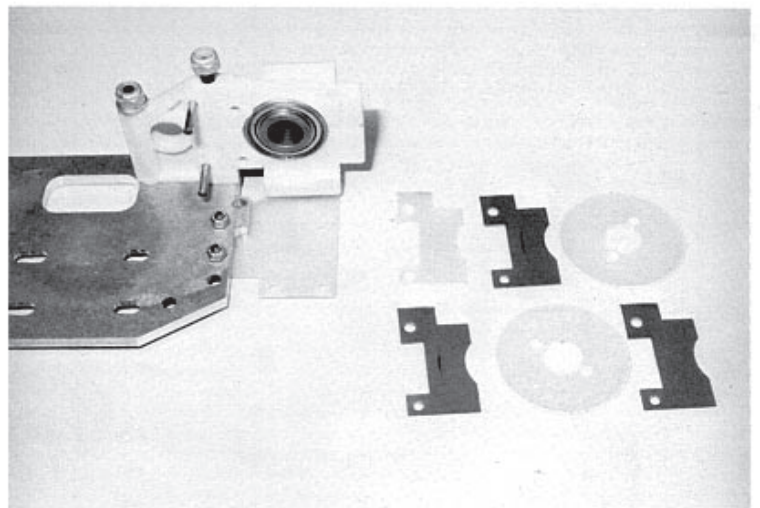

48

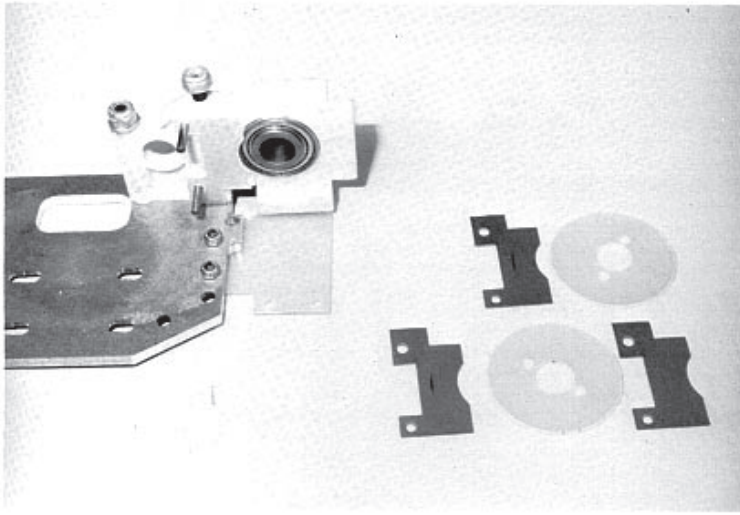

49

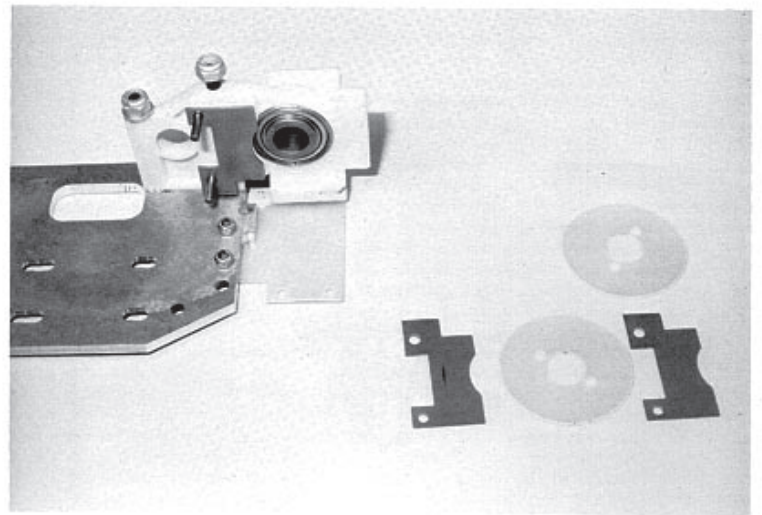

50

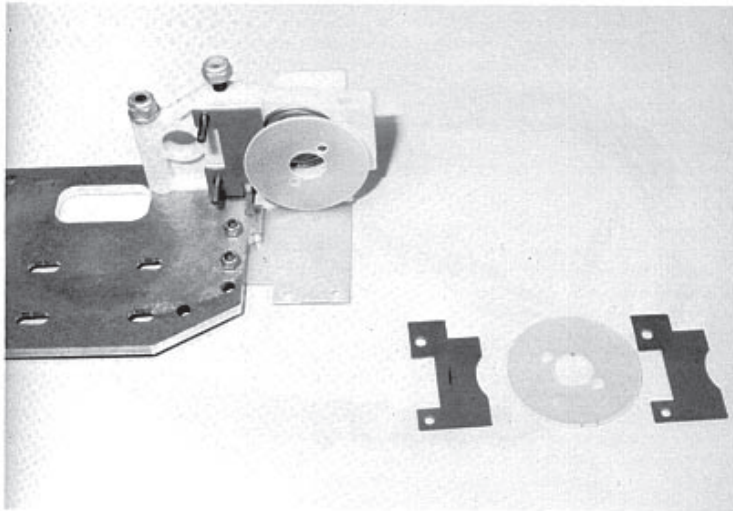

51

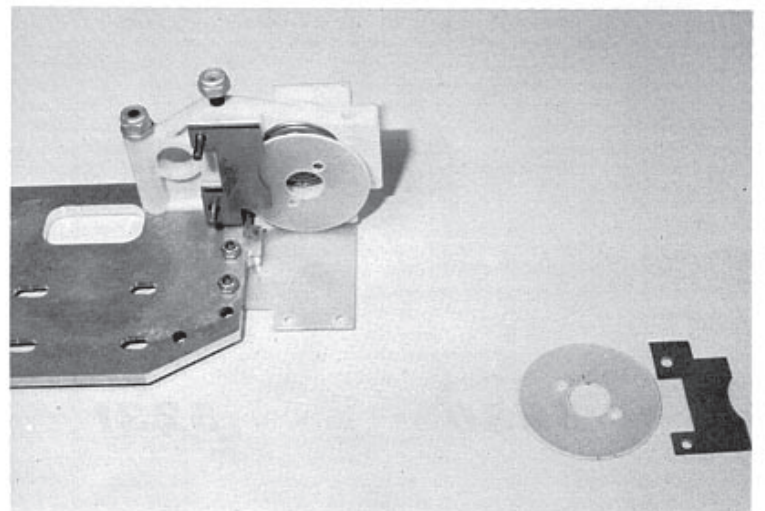

52

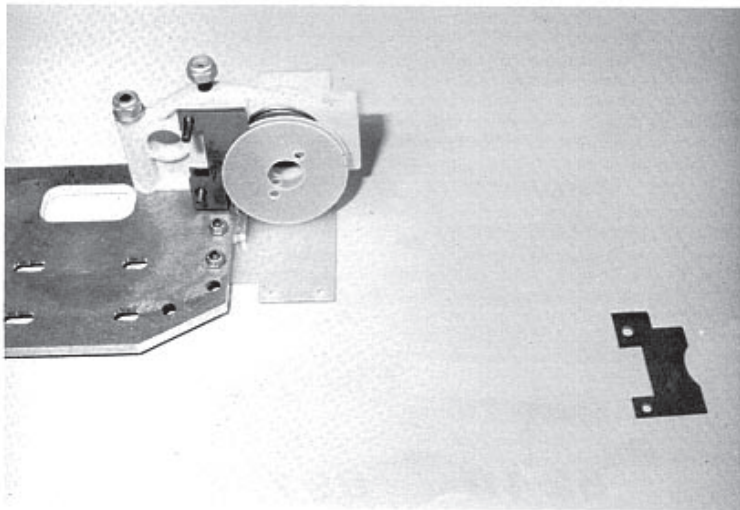

53

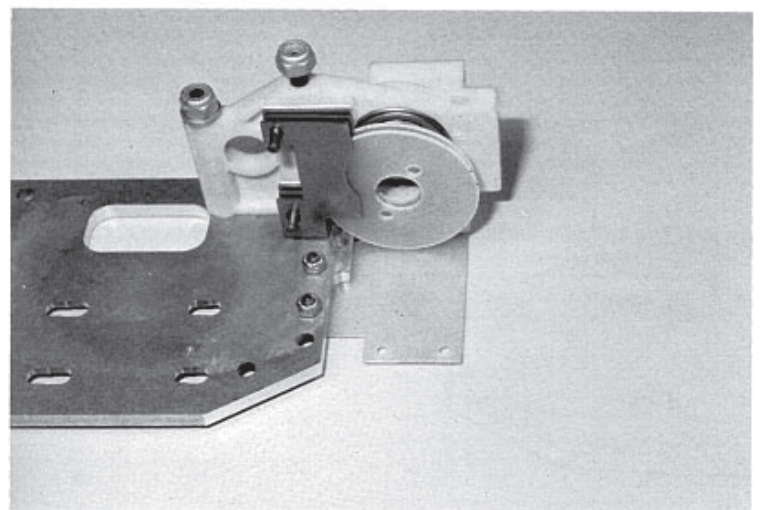

54

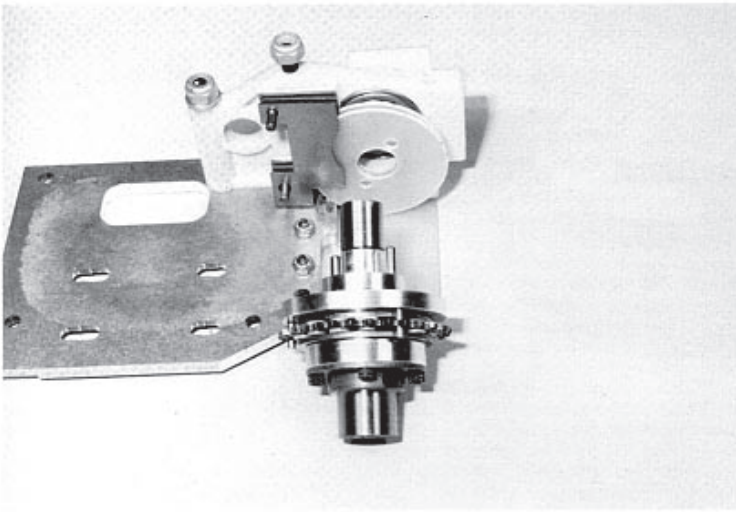

55

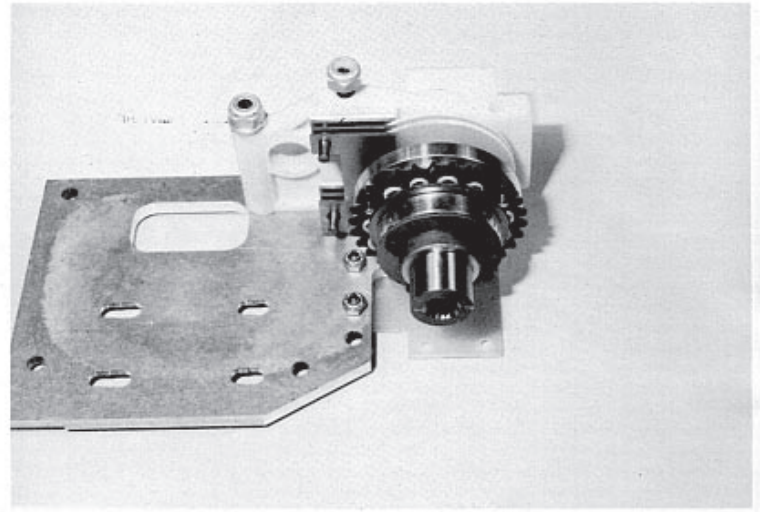

56

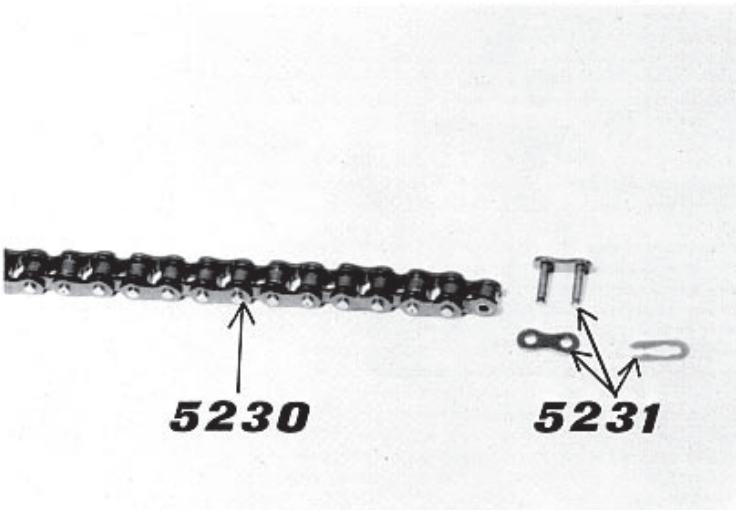

57

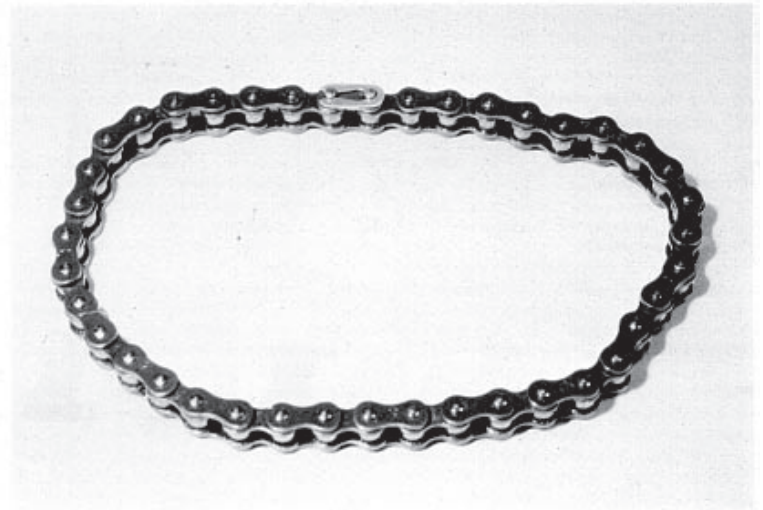

58

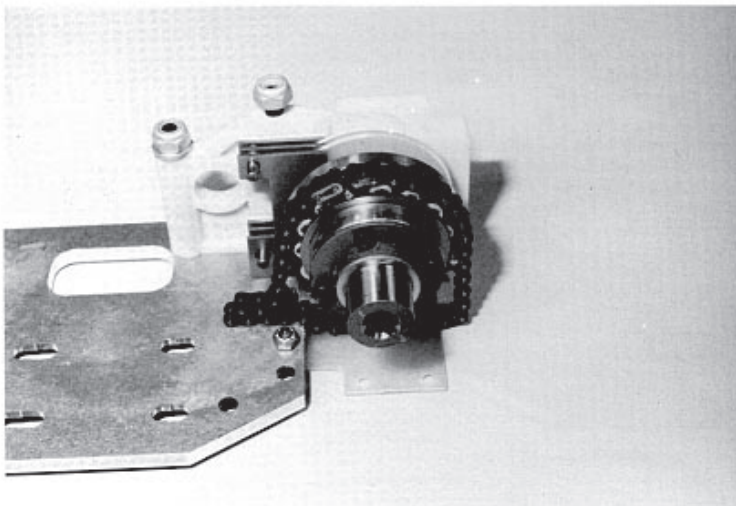

59

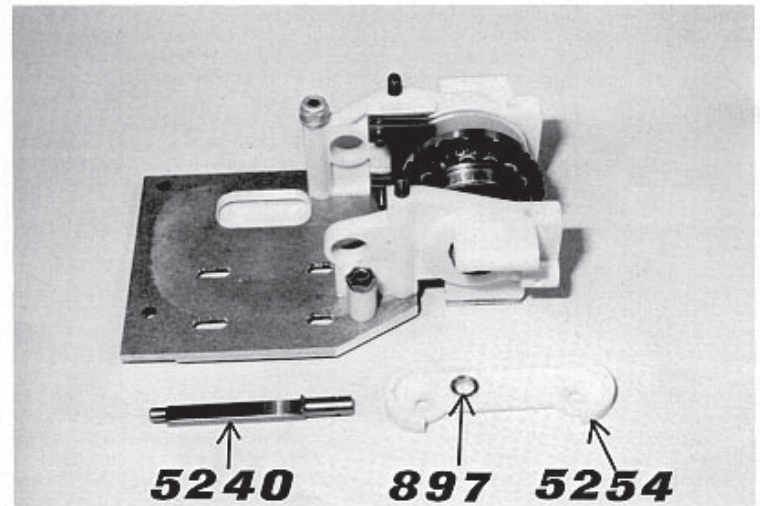

60

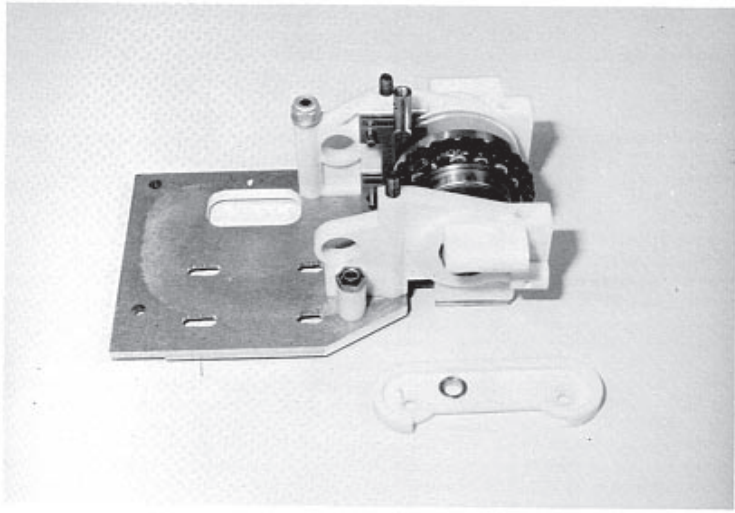

61

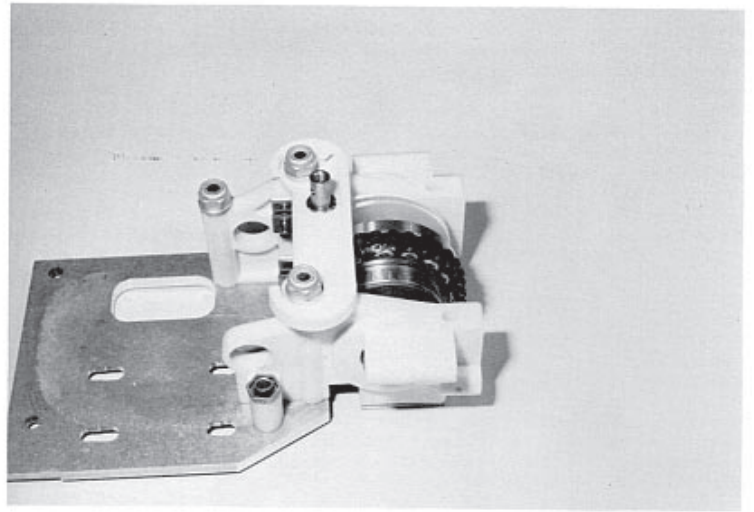

62

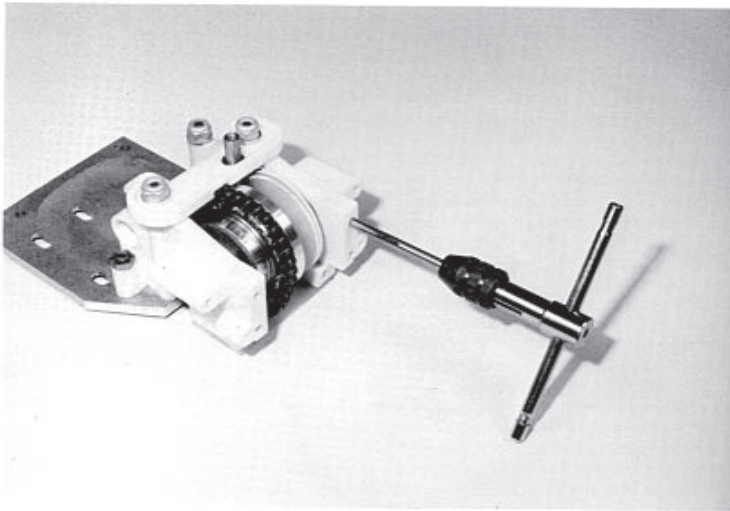

63

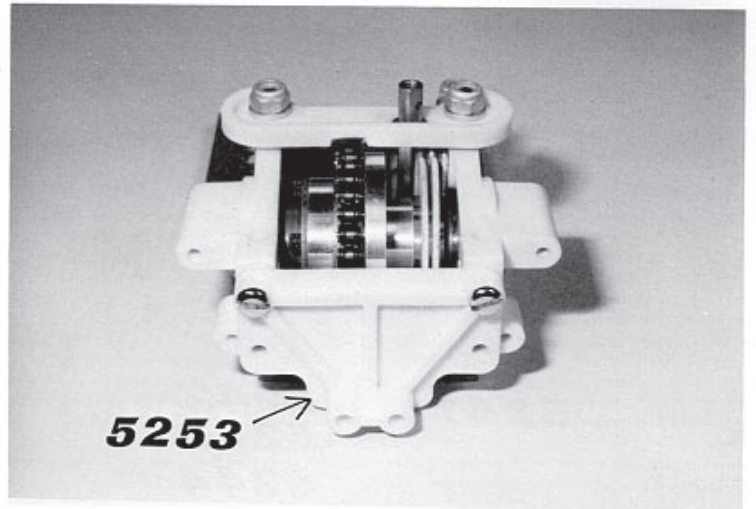

64

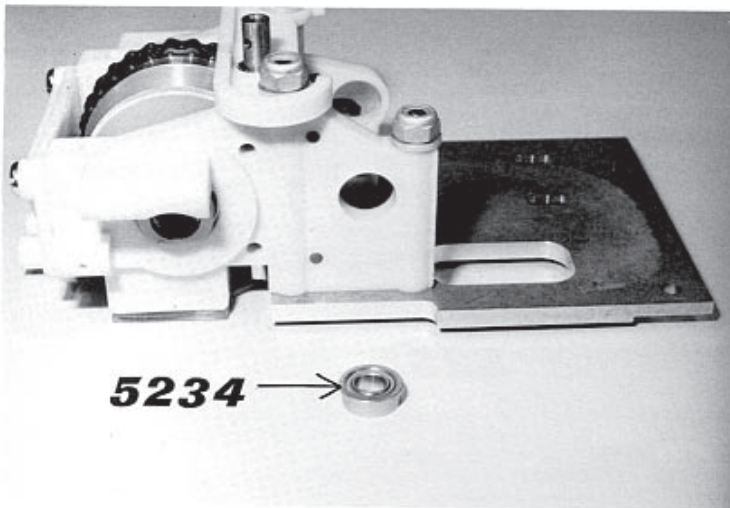

65

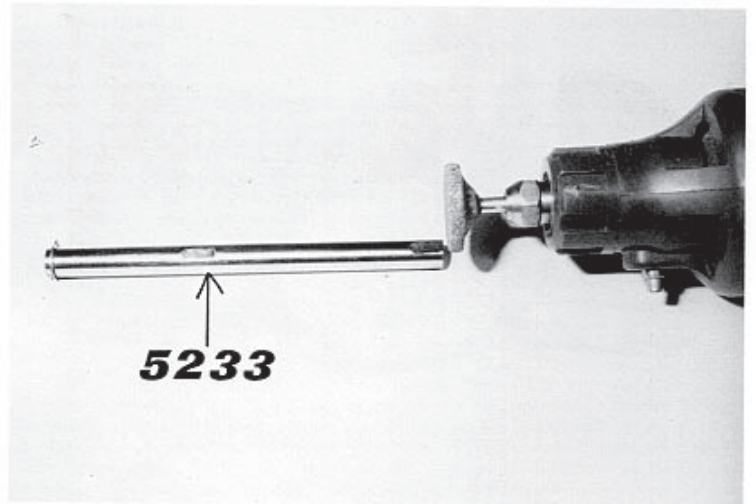

66

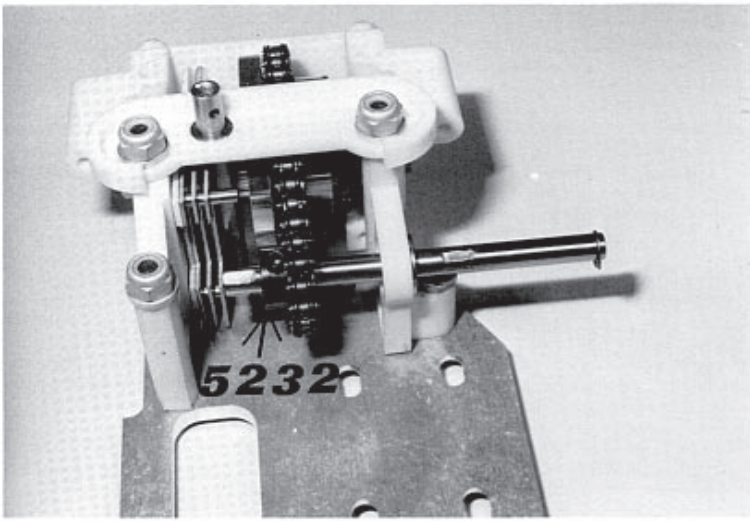

67

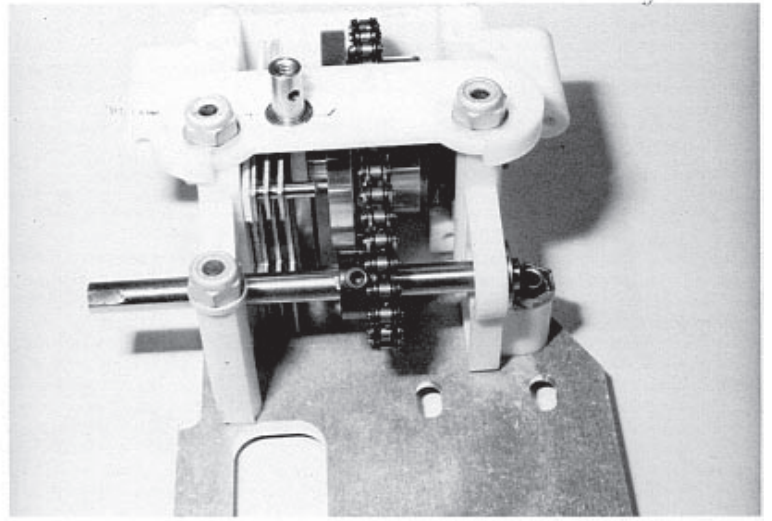

68

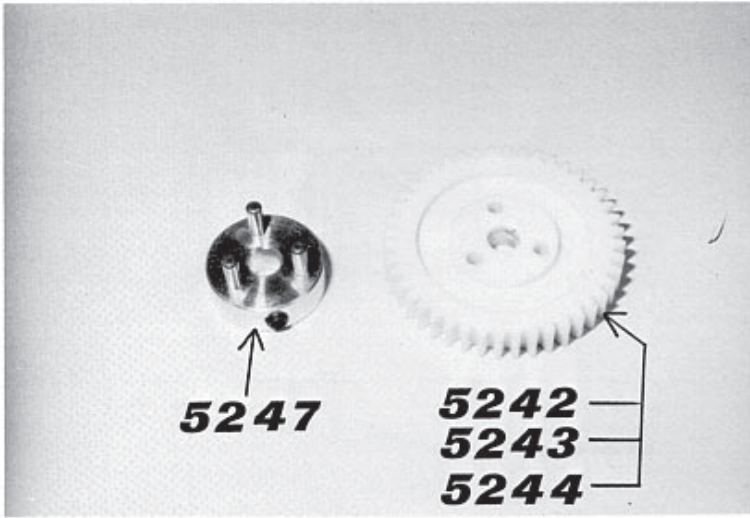

69

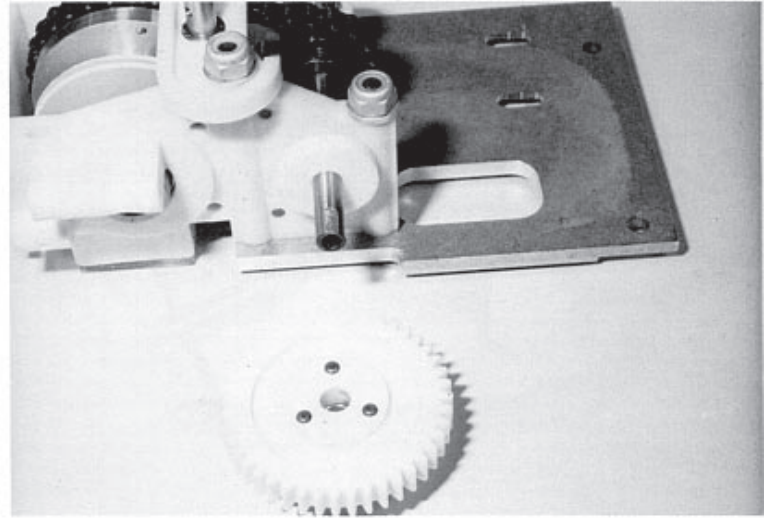

70

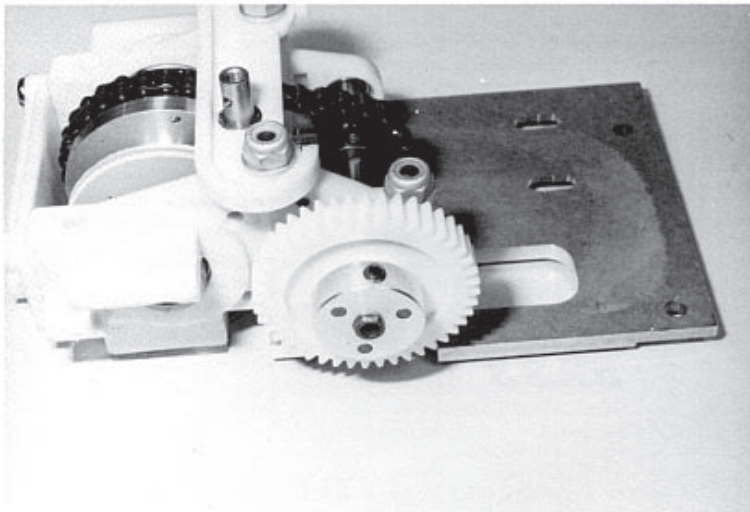

71

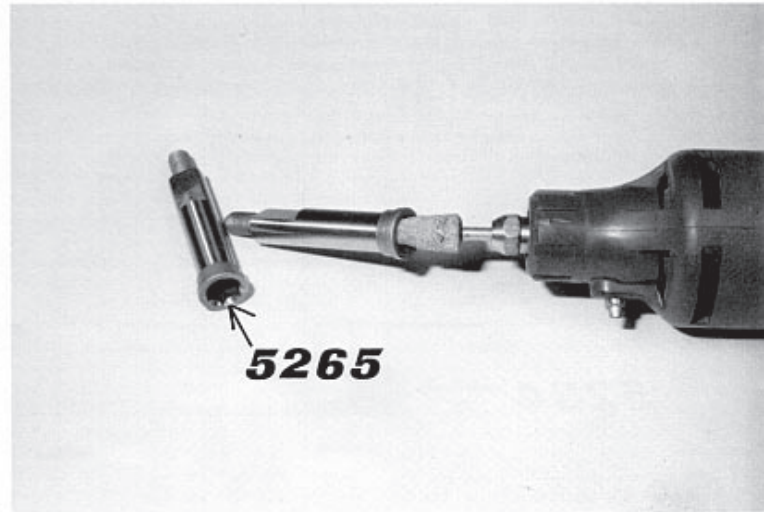

72

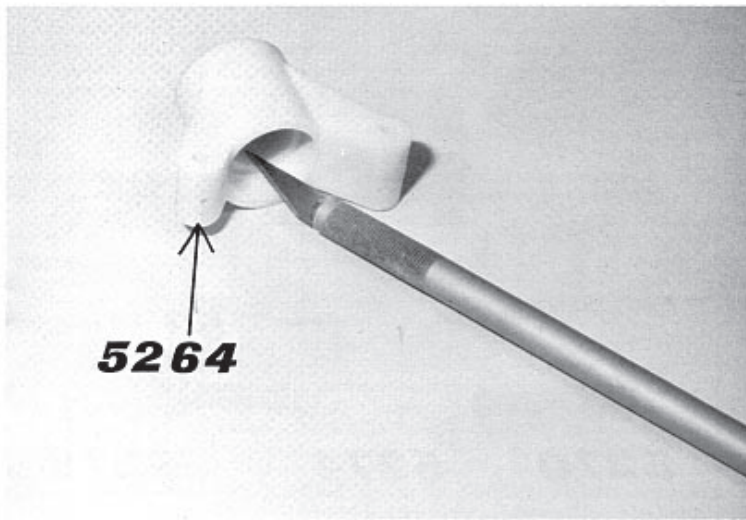

73

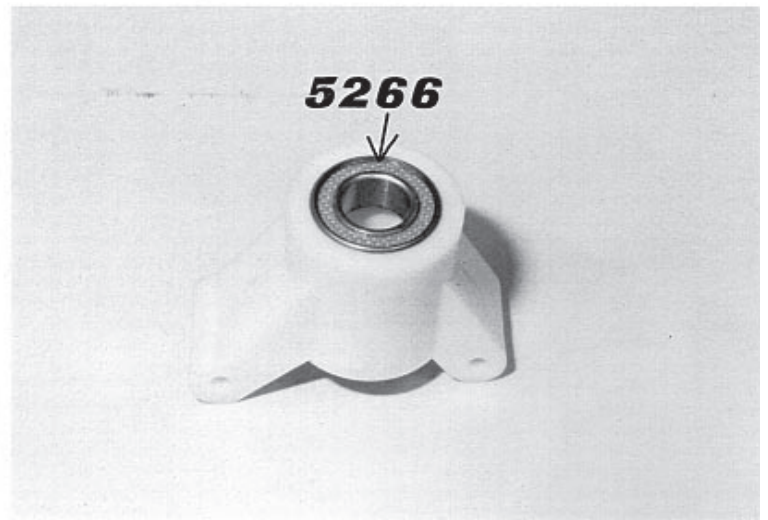

74

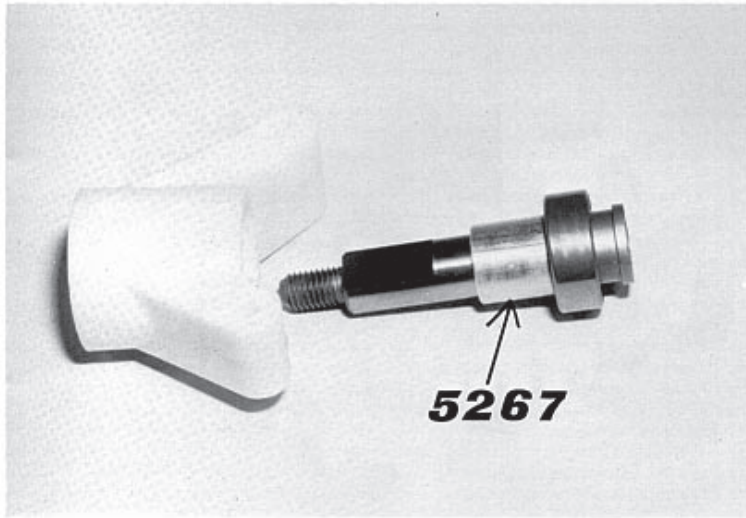

75

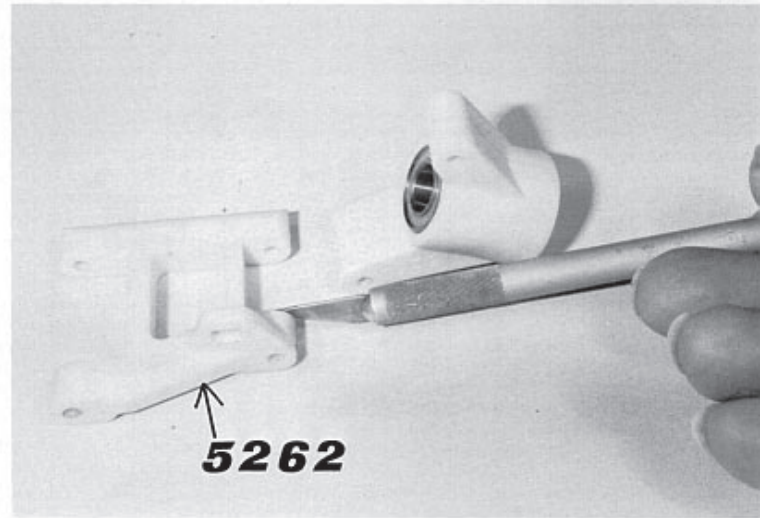

76

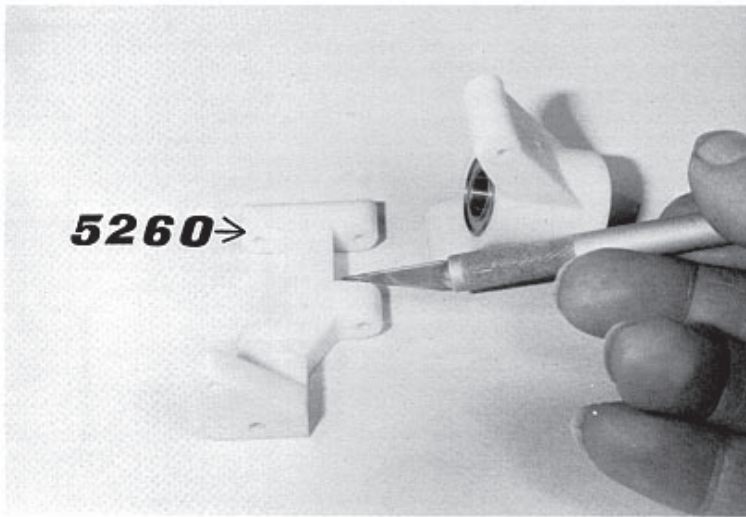

77

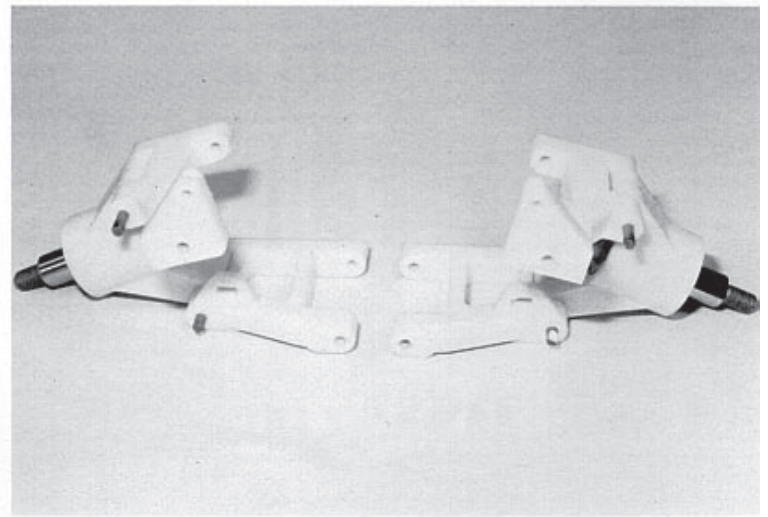

78

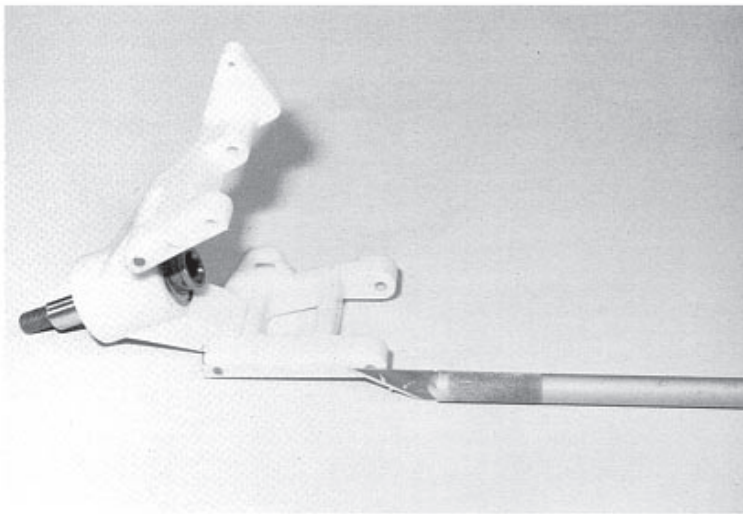

79

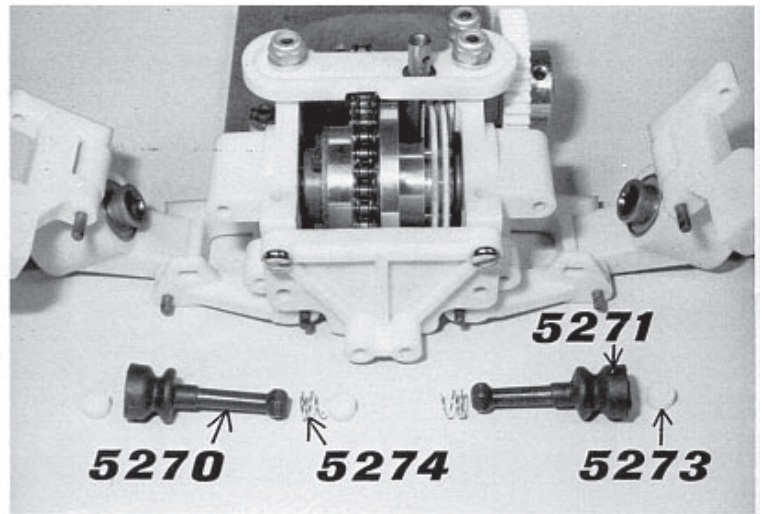

80

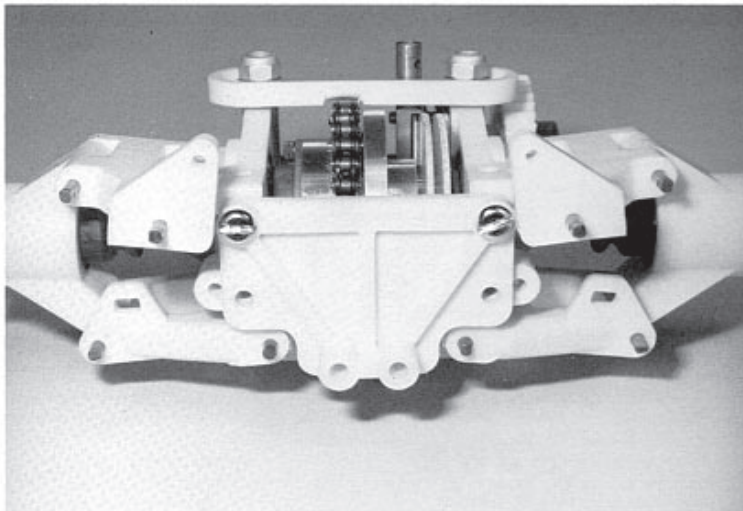

81

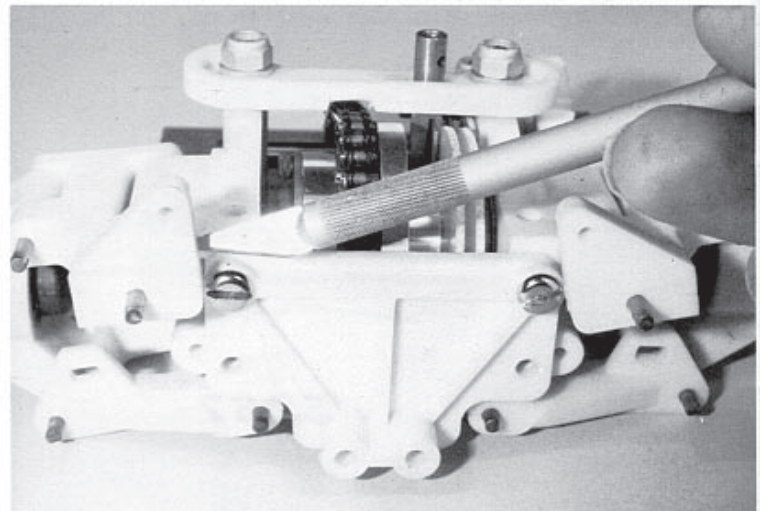

82

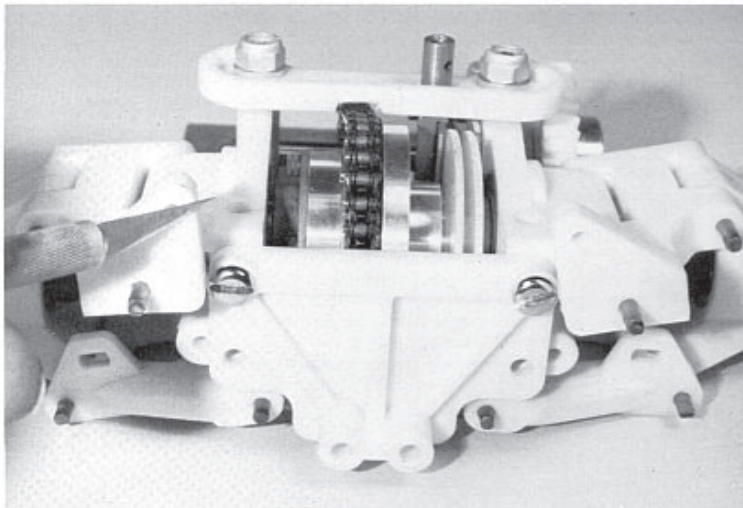

83

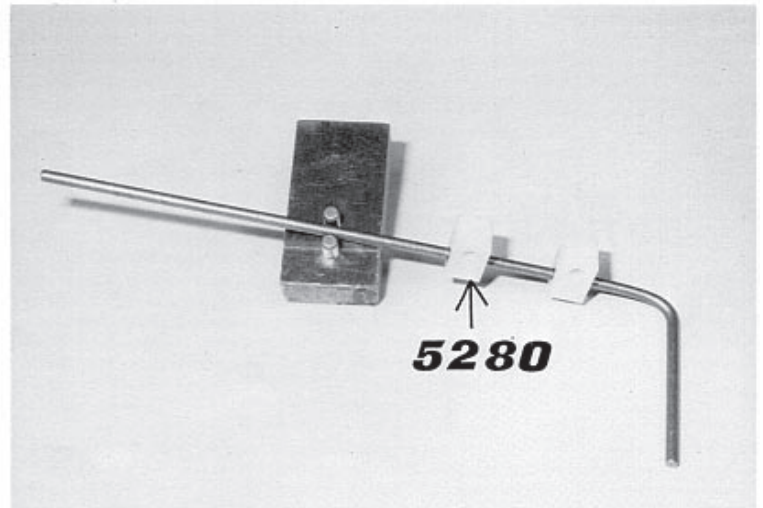

84

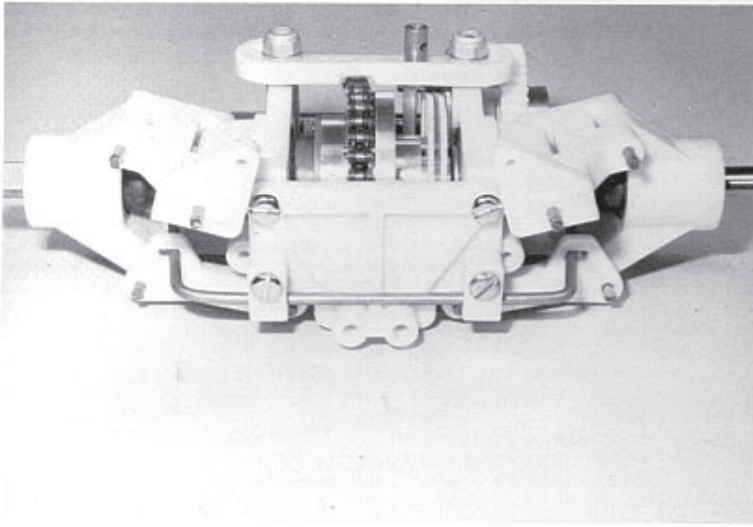

85

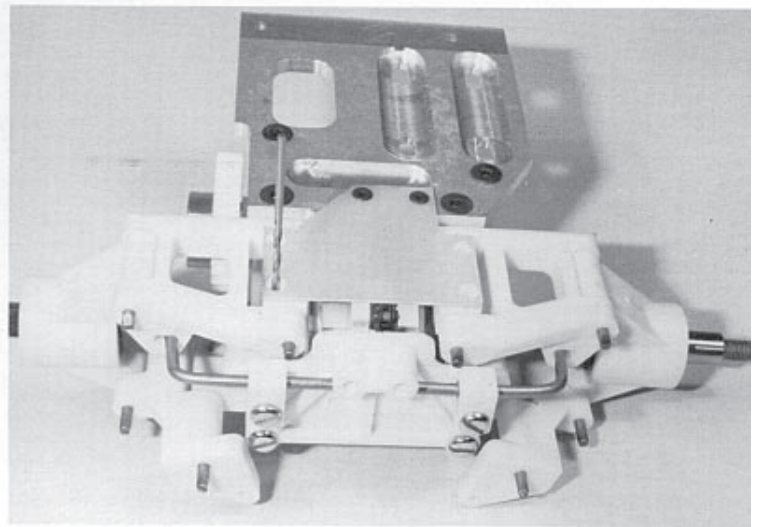

86

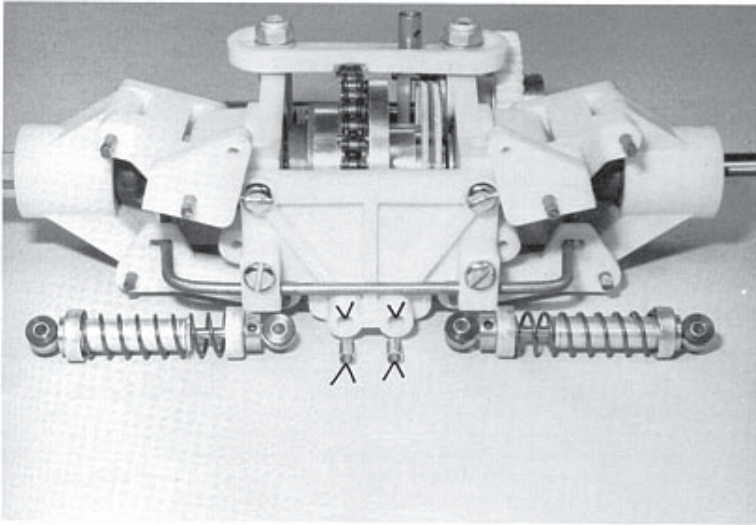

87

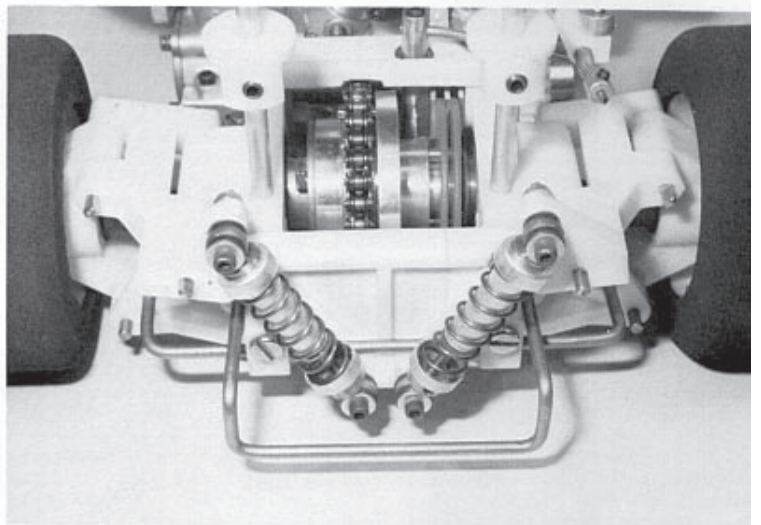

88

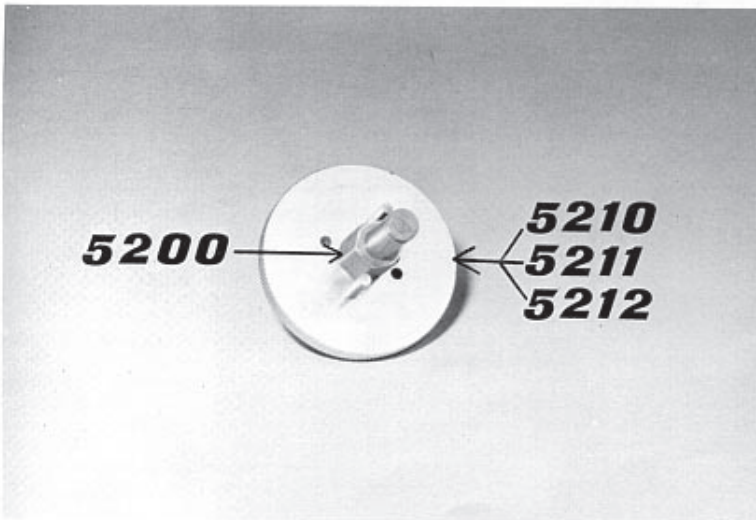

89

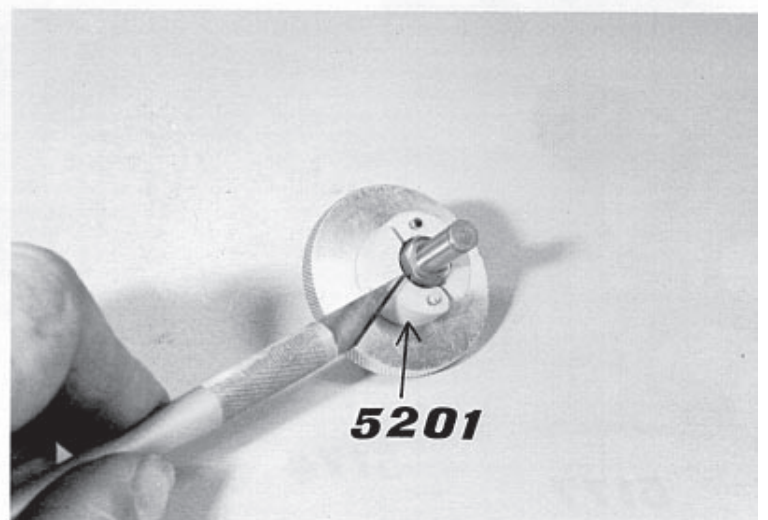

90

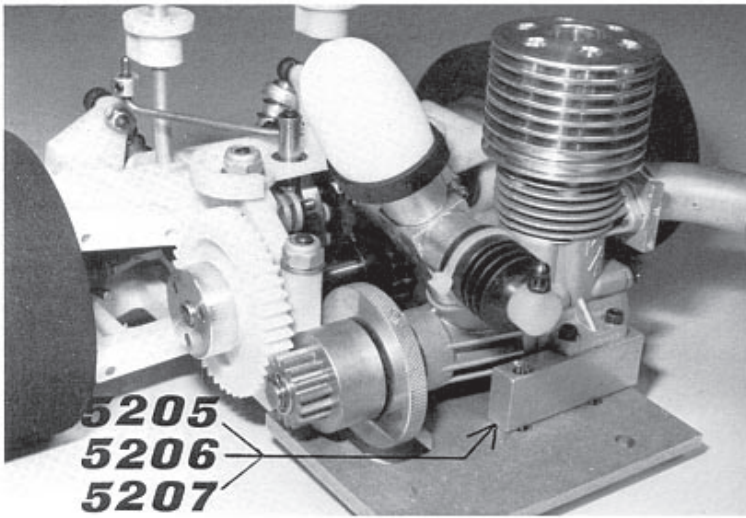

91

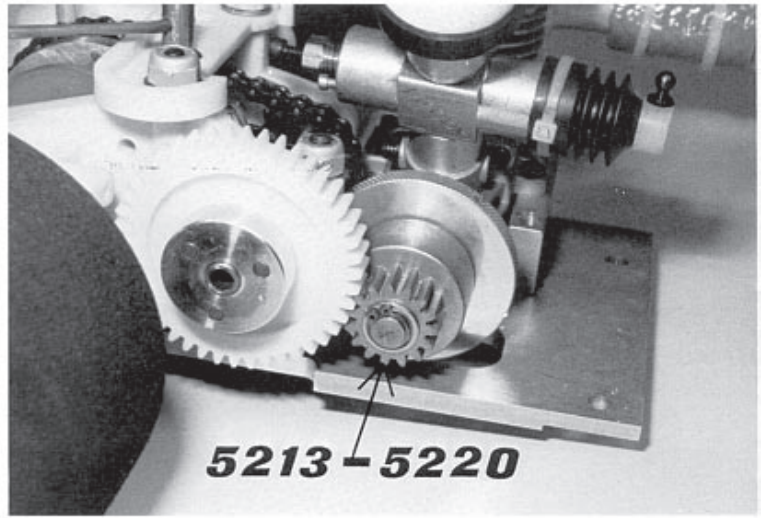

92

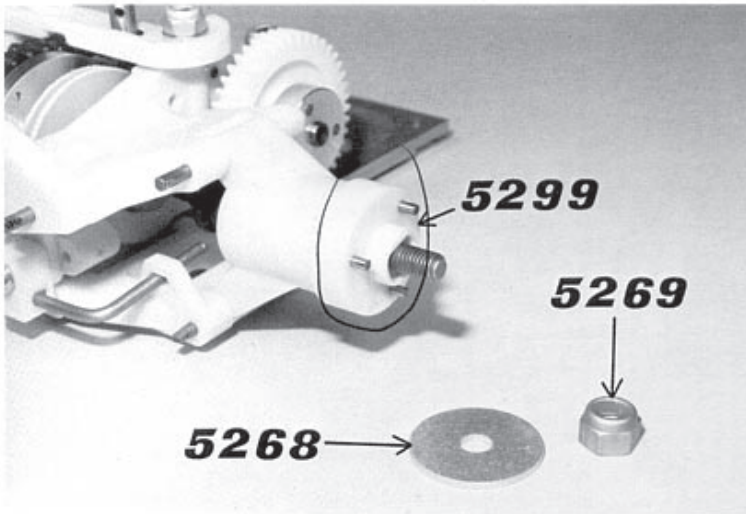

93

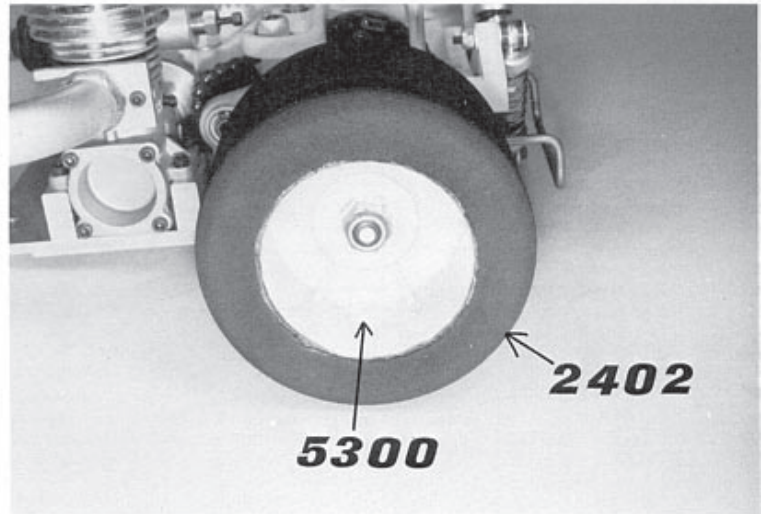

94

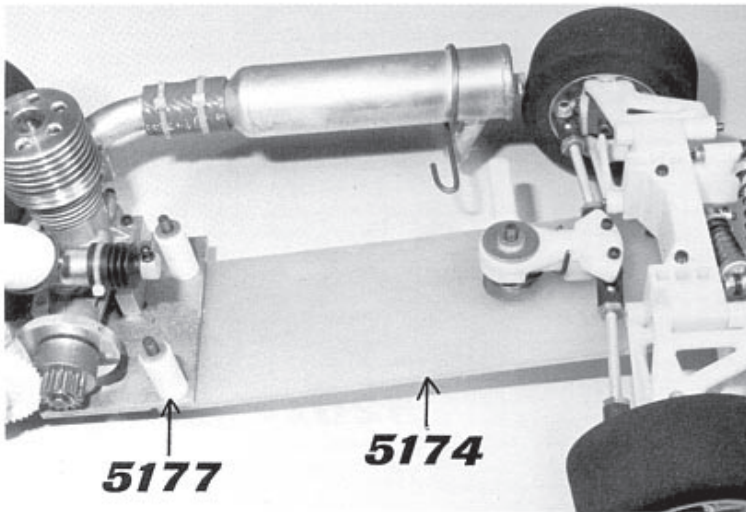

95

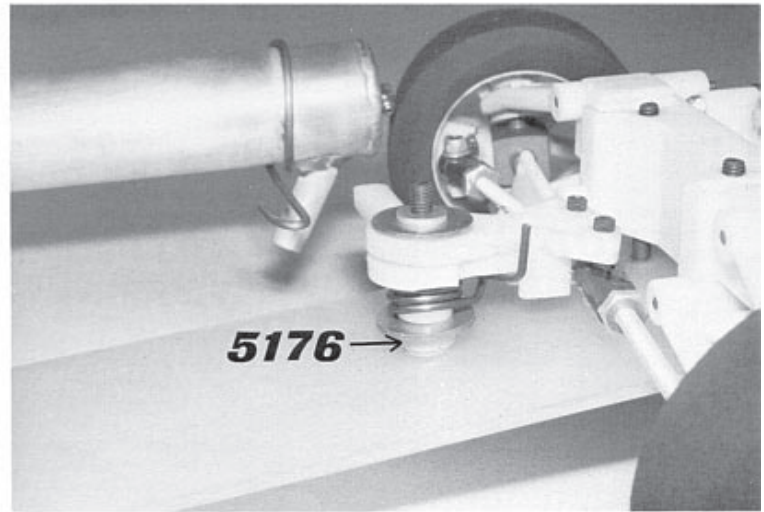

96

