

SC8e
SHORT COURSE



#80931 SC8e Kit



1:8 Scale 4WD Electric Offroad Race Truck Kit Manual

TEAM ASSOCIATED



:: Introduction

Thank you for purchasing this Team Associated product. This manual contains instructions and tips for building and maintaining your new SC8e Kit. Please take a moment to read through it and familiarize yourself with these steps.

:: SC8e Features

:: SC8e

- 16mm Big-Bore molded shocks with pre-load clips.
- Upgraded dual bell-crank steering with reduced bump-steer.
- Authentic scale, 1.5mm thick short course truck body.
- Black hard-anodized 7075 aluminum chassis with keyed suspension plates.
- 3mm center chassis stiffener plate.
- 3mm aluminum shock towers.
- Alloy steel turnbuckles.
- Caster blocks adjust 14, 16, or 18 degrees with molded inserts.
- 10mm thick arms.
- Molded suspension pivot bushings for adjustable pivot height.
- 4.30:1 ratio gearboxes.
- 3.5mm light CVA drivetrain.
- Rear molded CVA boots to keep dirt and mud out of rear joints.
- Functional full rollcage with integral dirt shields.
- Functional and realistic front and rear bumpers with mud flaps.
- Scale wheels and tires with foam inserts and bead guards.
- Rigid one-piece motor mount utilizes standard motor screw mounting pattern.
- Large speed control mounting area raised off of chassis to allow for easy screw mounting of common speed controllers.
- Speed control mounting area includes convenient switch-mounting boss.
- Utilizes 3 hook-and-loop straps to secure LiPo batteries into battery tray.
- Molded battery tray supports 7.4-14.8V battery packs with room for foam pads.
- Accepts two ROAR-approved 1:10 scale size 7.4v LiPo battery packs (#703 Reedy LiPo 5000 Pro (2), #704 Reedy LiPo 5000 w/connector (2), #705 Reedy LiPo 3200 w/connector (2), #709 Reedy LiPo 5000 35C (2)).
- New sealed receiver box for proper electronics placement.
- Receiver, servo, and battery tray remove from vehicle in one piece for easy maintenance and cleaning.
- Convenient wire routing keeps critical electronic wires out of drivetrain components and simplifies disassembly.
- Includes pinion gear (15T) and molded spur gear (46T).
- Motor, ESC, transmitter, and batteries are not included.

Alert! The Differentials and Shocks are pre-assembled. They need to be filled with fluid before use.

:: Additional

:: Required Items

Your SC8e Short Course Truck comes unassembled and requires the following items to complete your kit:

- 1/8 Scale Specific Speed Control and Motor.
- High Torque Steering Servo (AE Part # 29167)
- 2 Channel Radio Set - FM/PCM recommended.
- AA-Size Batteries for Transmitter (x8)
- Thread Lock Compound (AE Part#1596)
- Lexan Specific Spray Paint
- FT Body Scissors (AE Part#1737)
- Reamer/Hole Punch
- FT Hex Driver Set (AE Part #1541)
- Hobby Knife
- Needle Nose Pliers
- Wire Cutters
- Plug Extension (depending on ESC)

:: SC8e Notes

Your SC8e Manual has a 1:1 pullout of all the included hardware in the back. Use this to correctly size up your hardware for easy installation and kit building ease!

Also, there is a Team setup sheet and a blank setup sheet for your records. Use the setup sheet to keep track of any changes you make to your vehicle.

The Catalog will have an included supplement page with all the new electric conversion parts, as well as some new 1/8 scale options!



Associated Electrics, Inc.
26021 Commercentre Dr.
Lake Forest, CA 92630



<http://www.TeamAssociated.com> • <http://www.RC10.com>

Customer Service
Tel: 949.544.7500
Fax: 949.544.7501

:: Front and Rear Differentials

BAG A

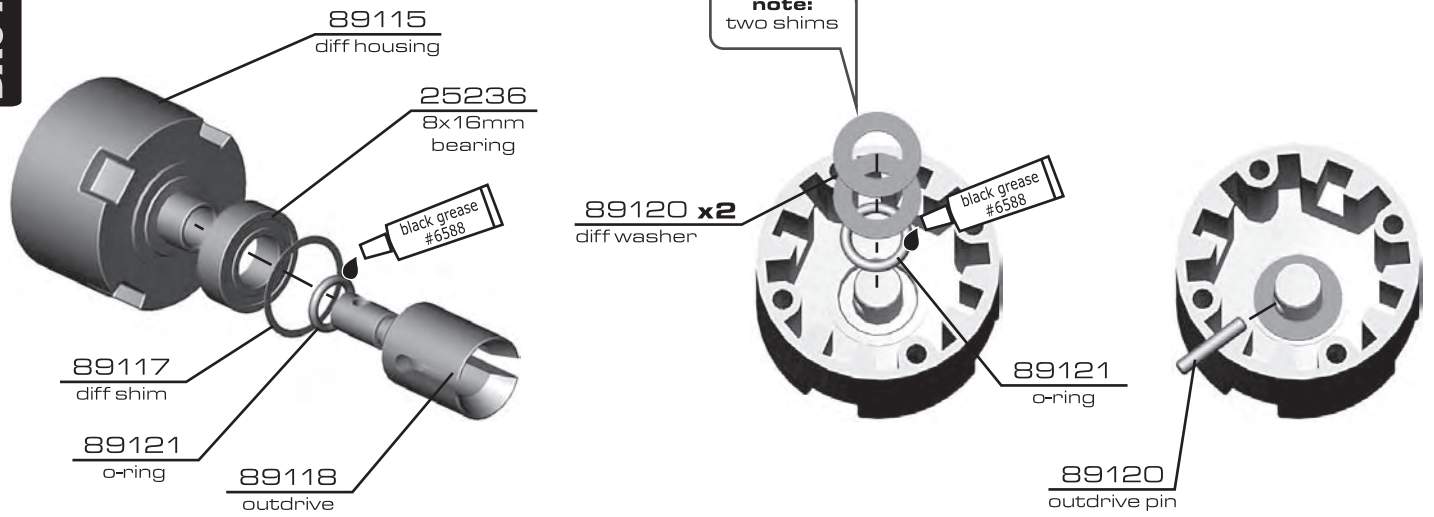

:: Front and Rear Differentials (cont.)

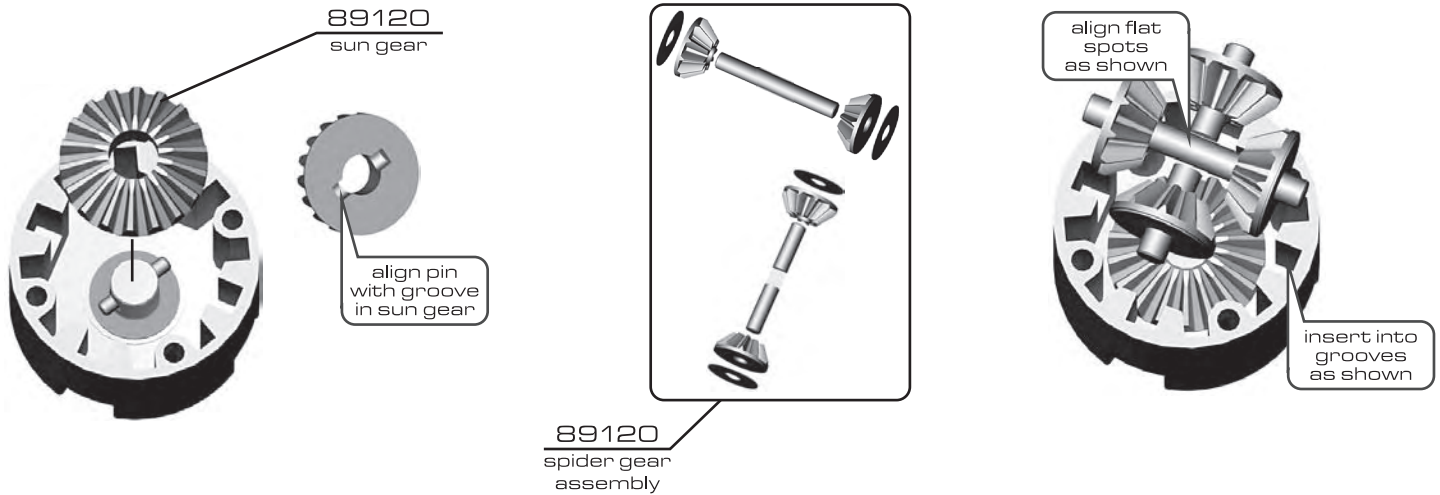

:: Front and Rear Differentials (cont.)

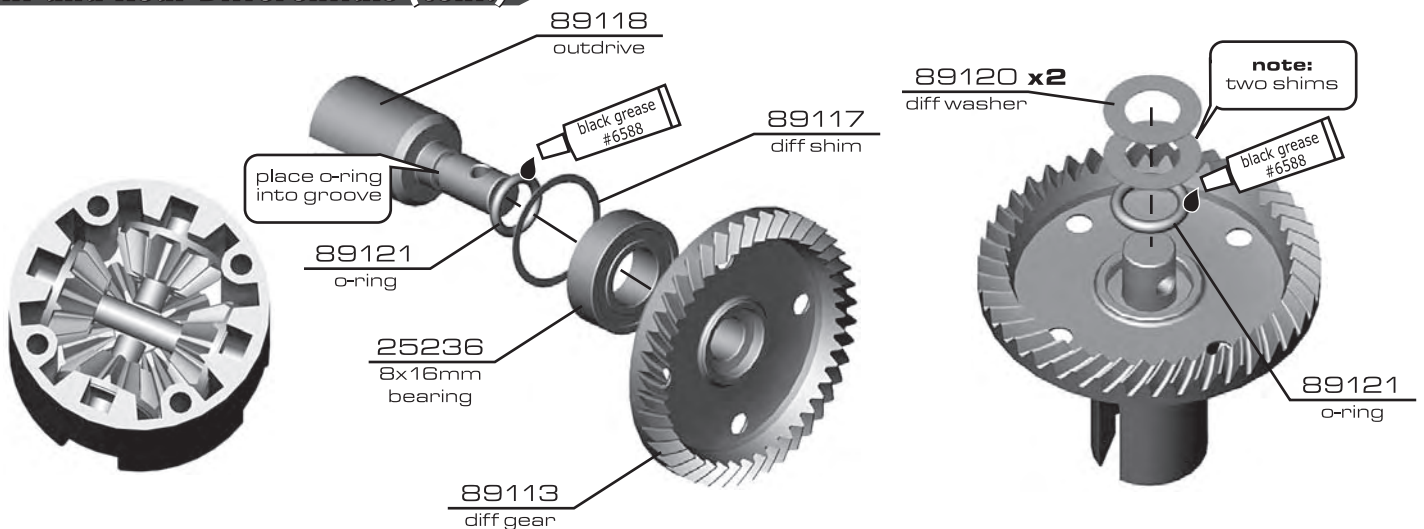

:: Front and Rear Differentials (cont.)

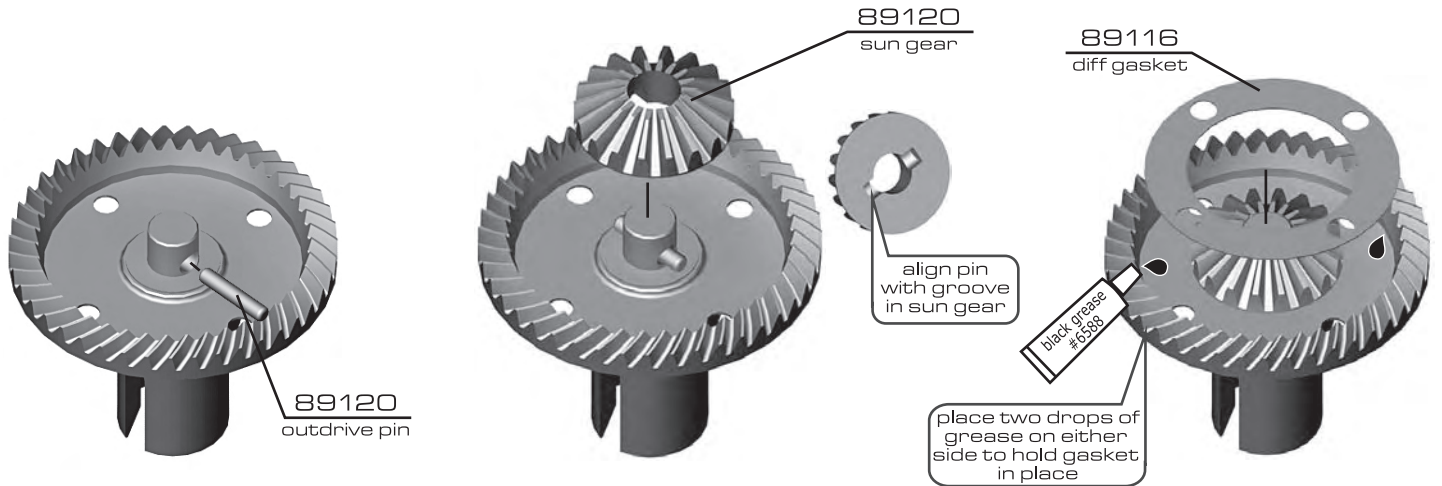

:: Front and Rear Differentials (cont.)

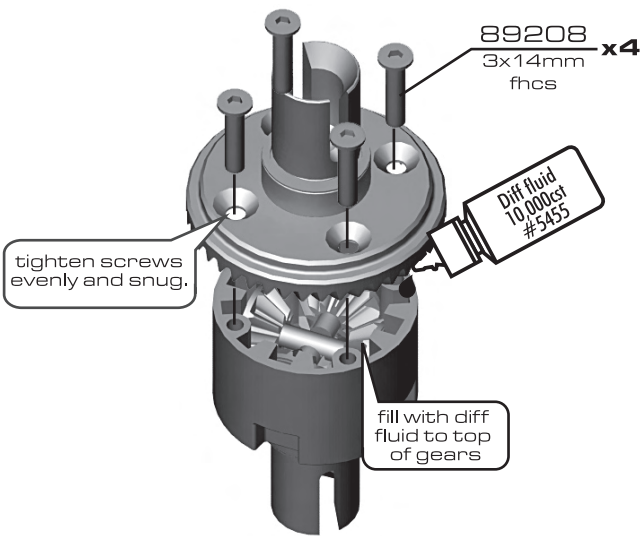

:: Center Differential

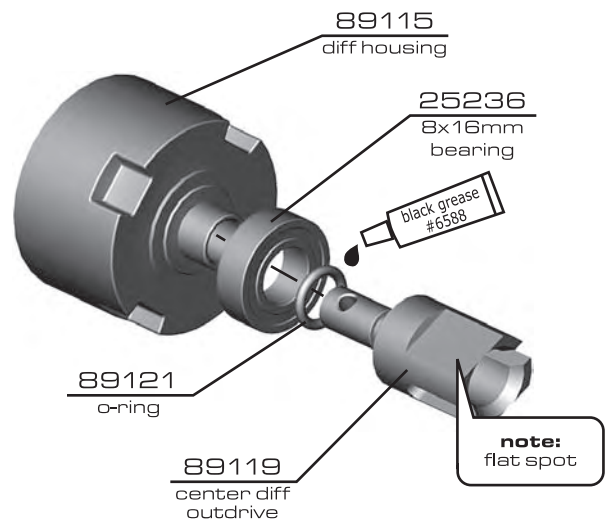

:: Center Differential (cont.)

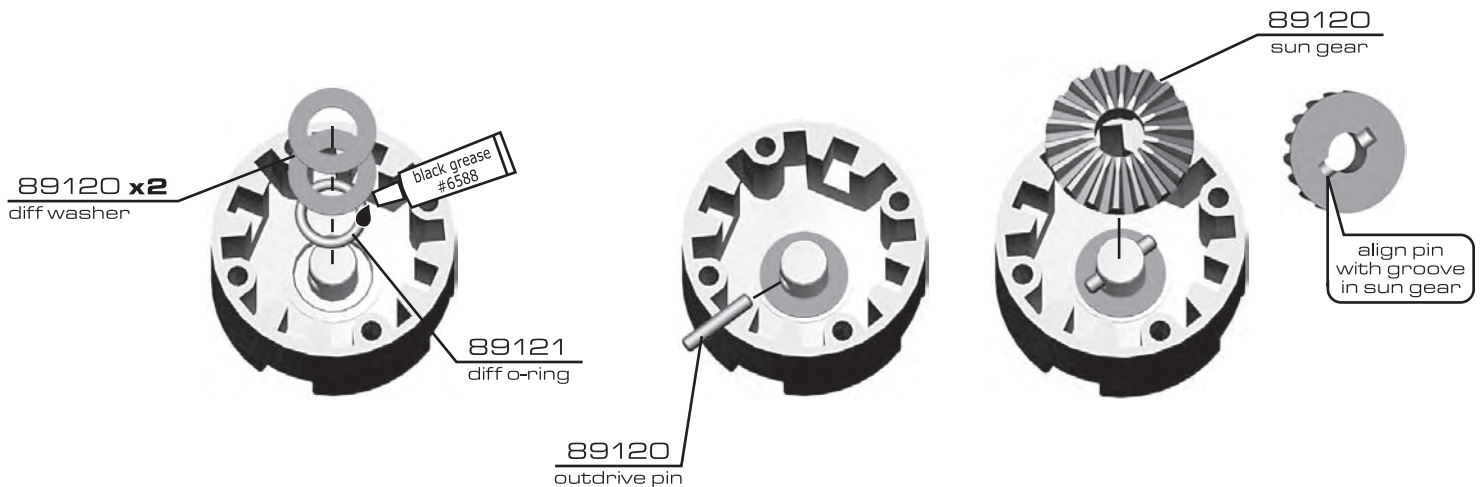

:: Center Differential (cont.)



89120 spider gear assembly

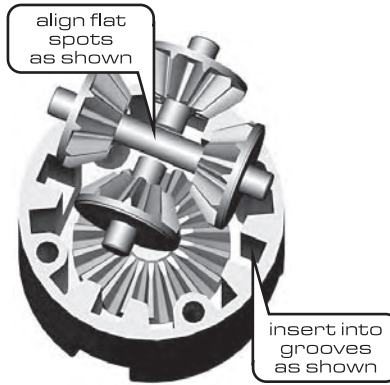

:: Center Differential (cont.)

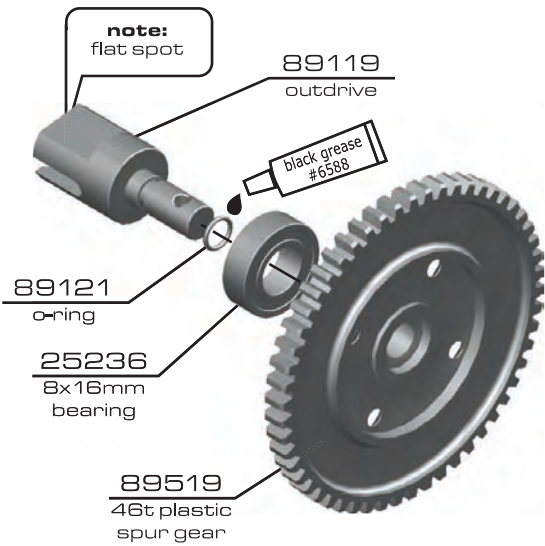

89121 o-ring

25236 8x16mm bearing

89519 46t plastic spur gear

89119 outdrive

black grease #6588

89120 x2 diff washer

black grease #6588

89121 diff o-ring

89120 outdrive pin

:: Center Differential (cont.)

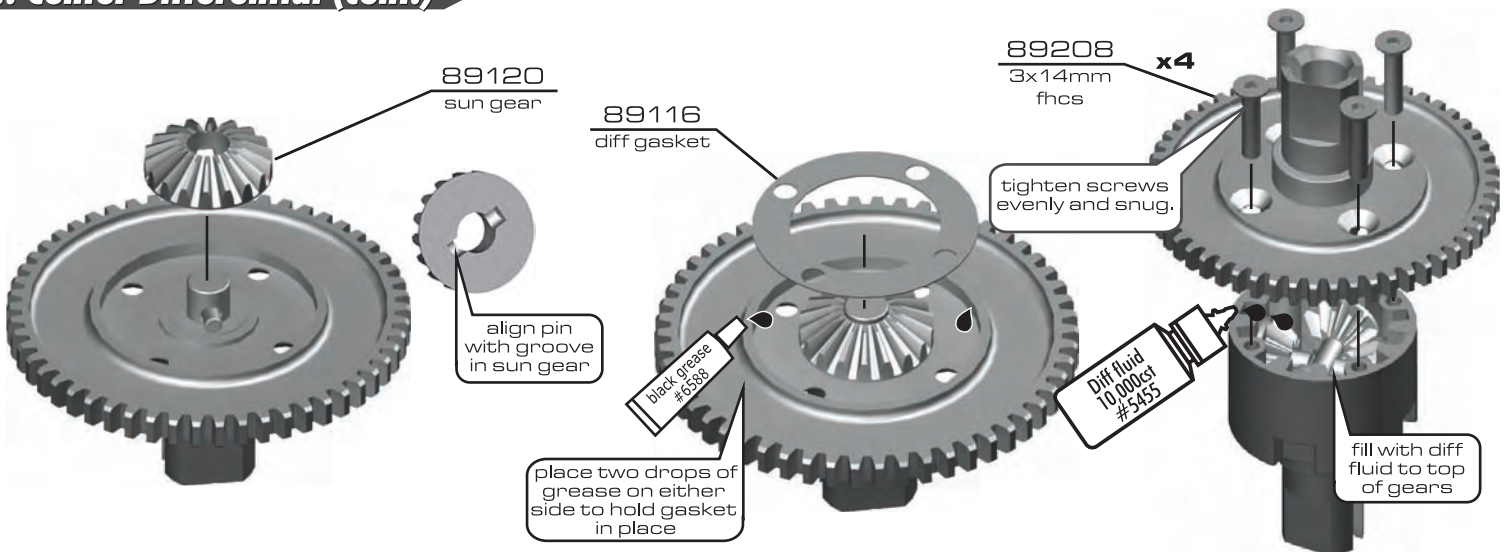

89120 sun gear

89116 diff gasket

align pin with groove in sun gear

place two drops of grease on either side to hold gasket in place

89208 3x14mm fhcs x4

tighten screws evenly and snug.

black grease #6588

Diff fluid 10,000vis #5455

fill with diff fluid to top of gears

:: Servo Turnbuckle

BAG B

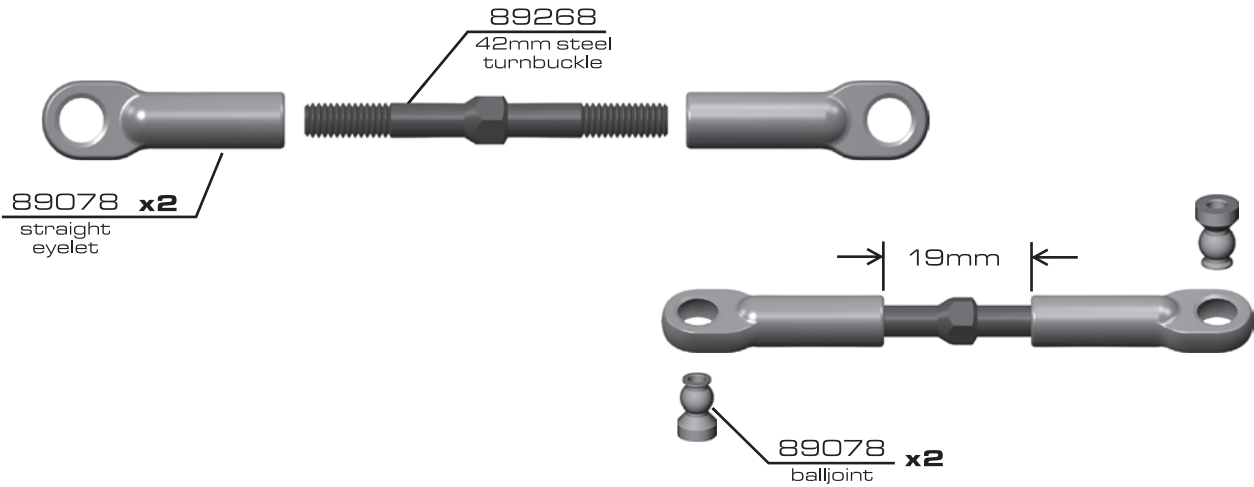

:: Steering Turnbuckles

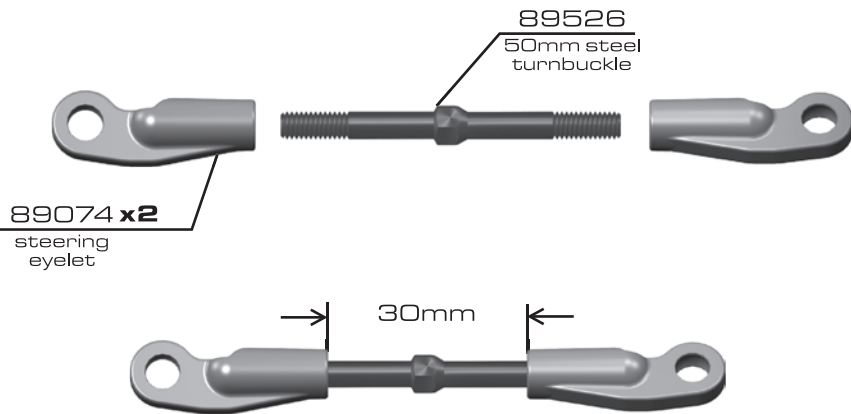

Builds X2

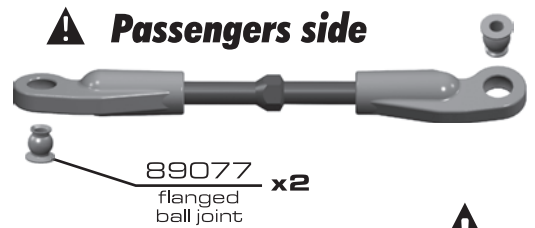

▲
*note the direction of
the turnbuckles during
installation!



:: Camber Turnbuckles

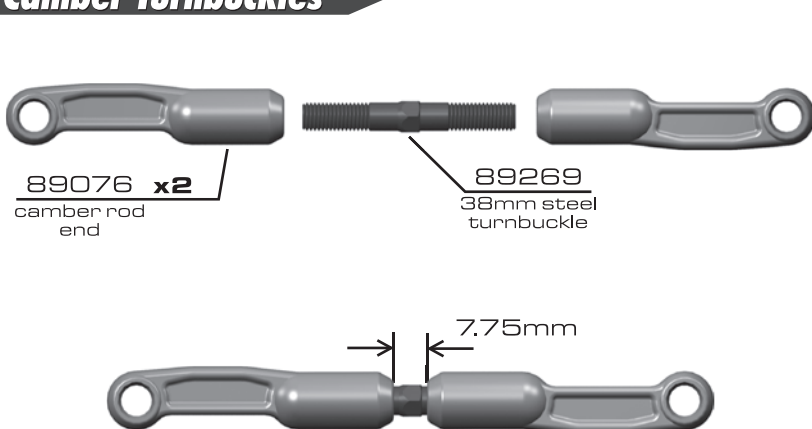

Builds X2



▲
*note the direction of
the turnbuckles during
installation!



:: Shocks

BAG C

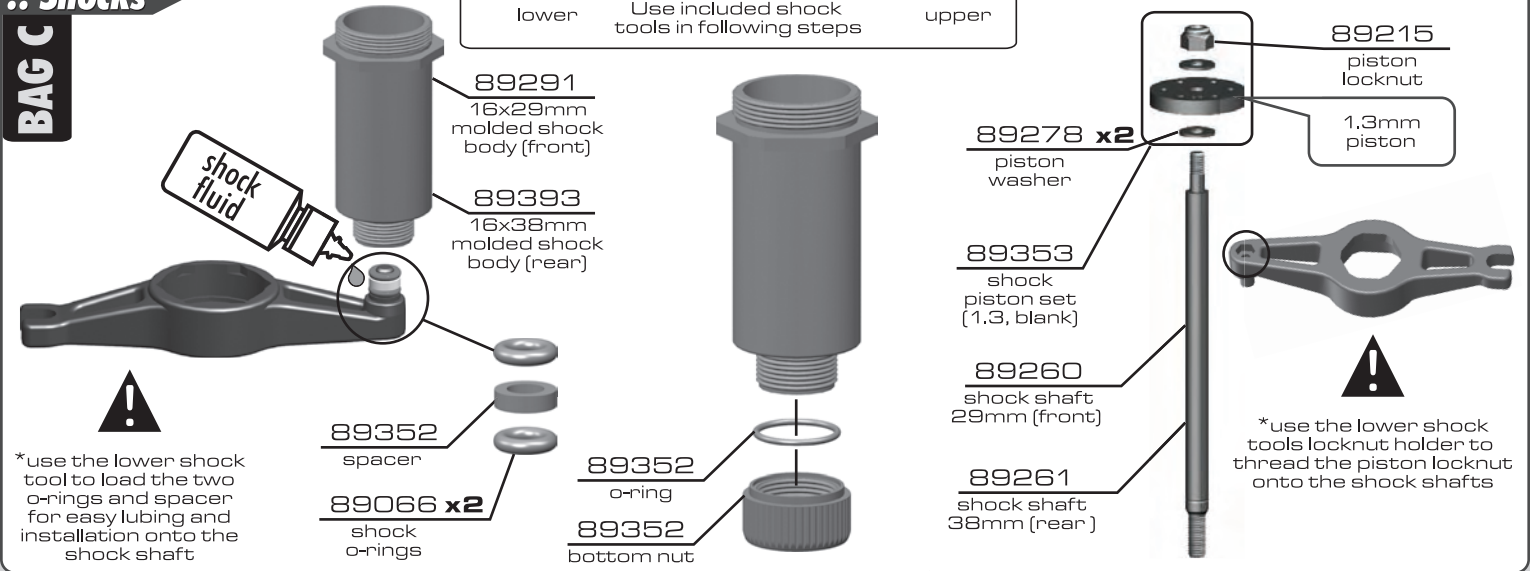

:: Shocks (cont.)

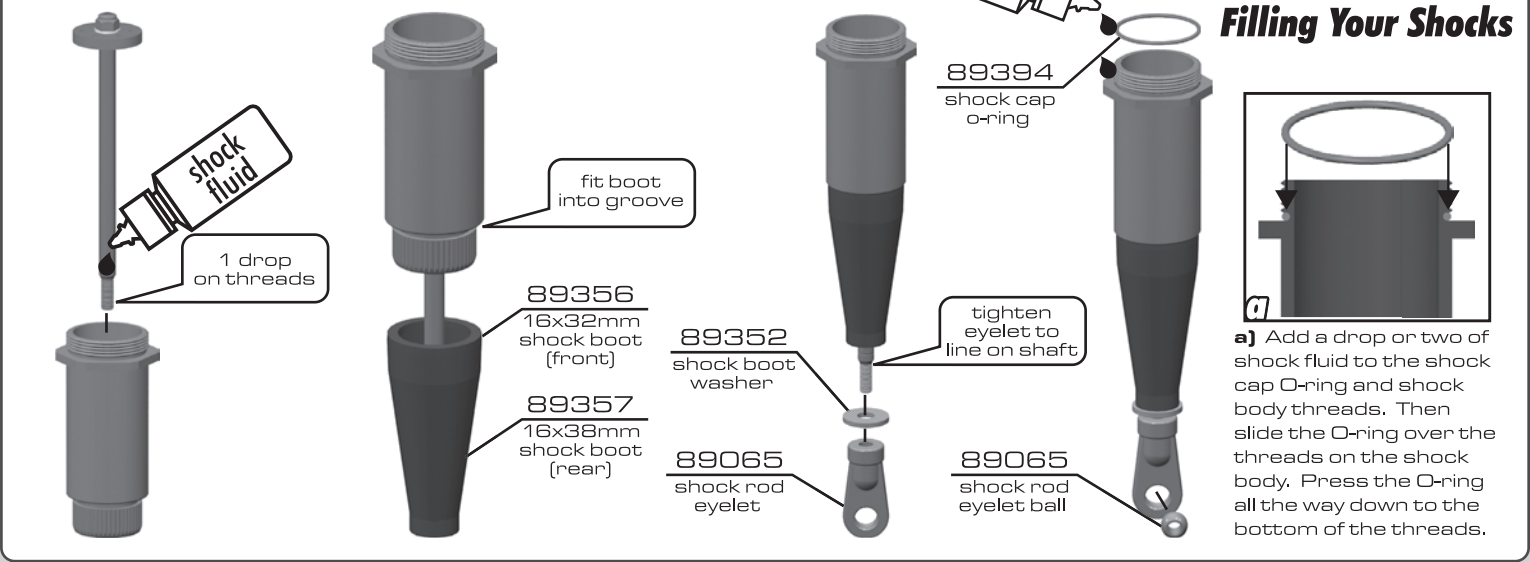

:: Shocks (cont.)

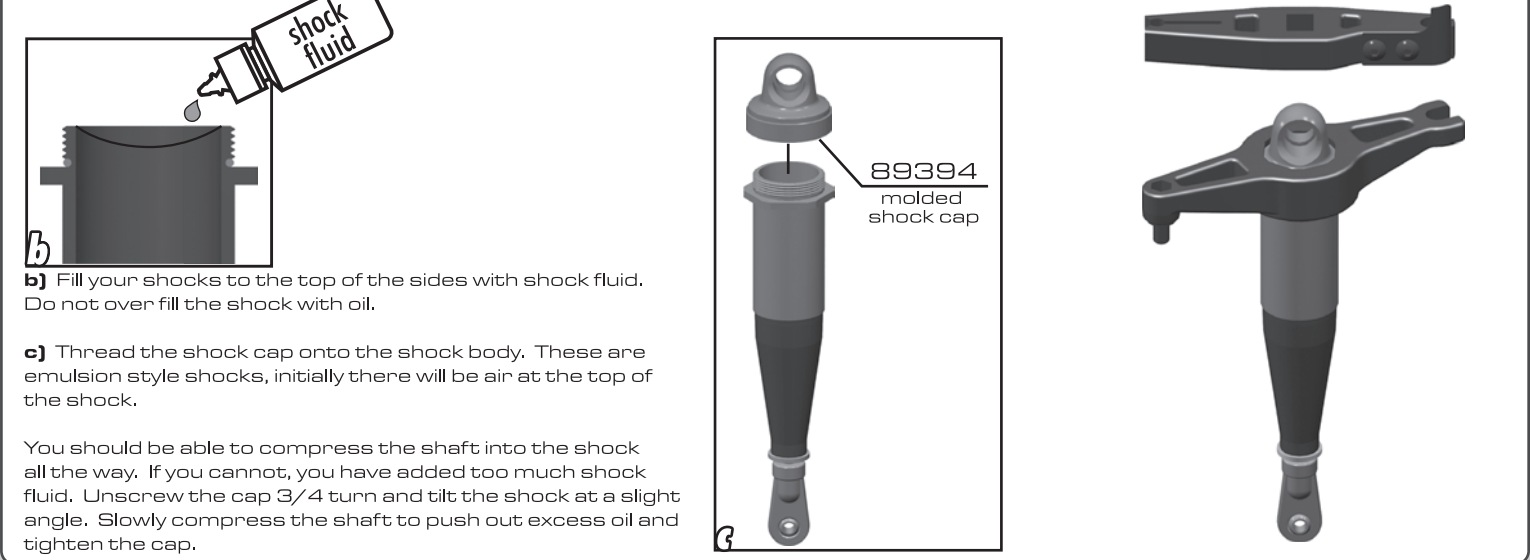

:: Shocks (cont.)

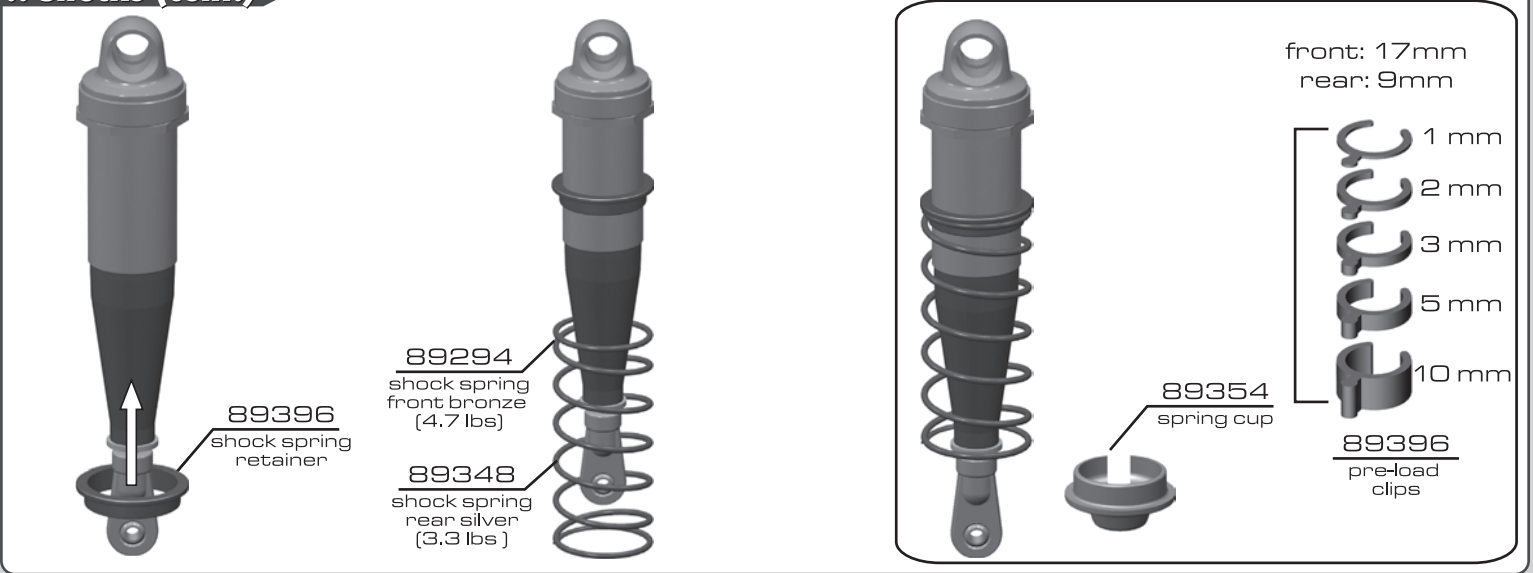

:: Steering

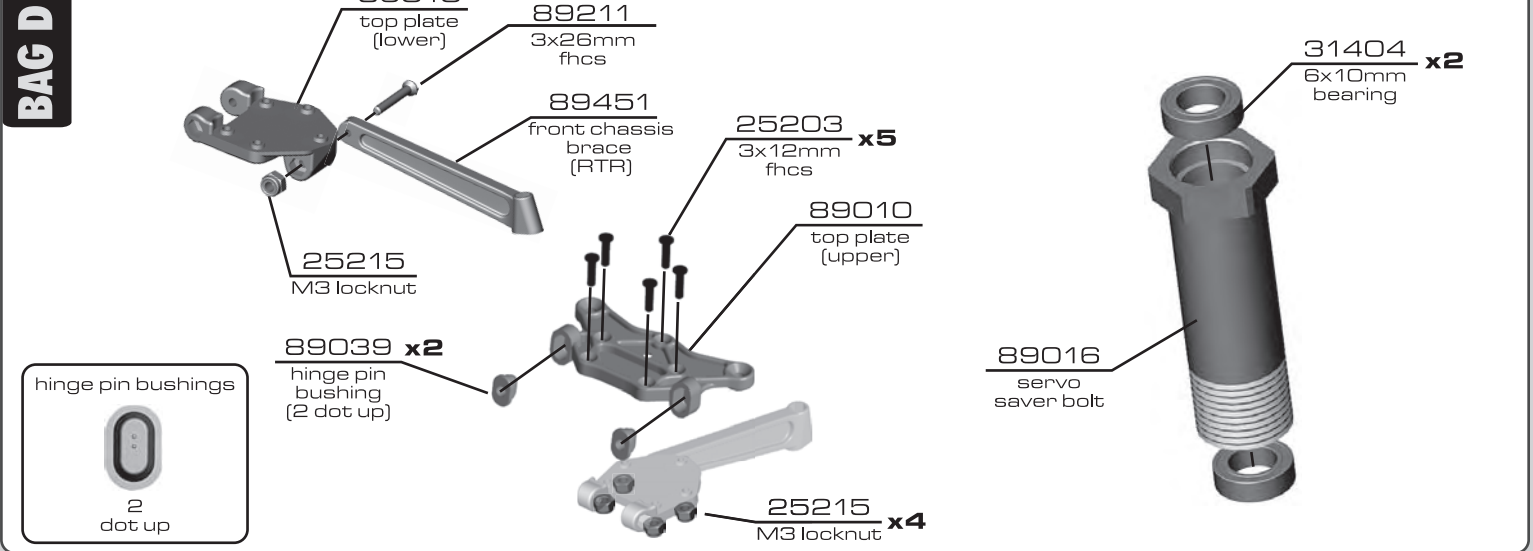

:: Steering (cont.)

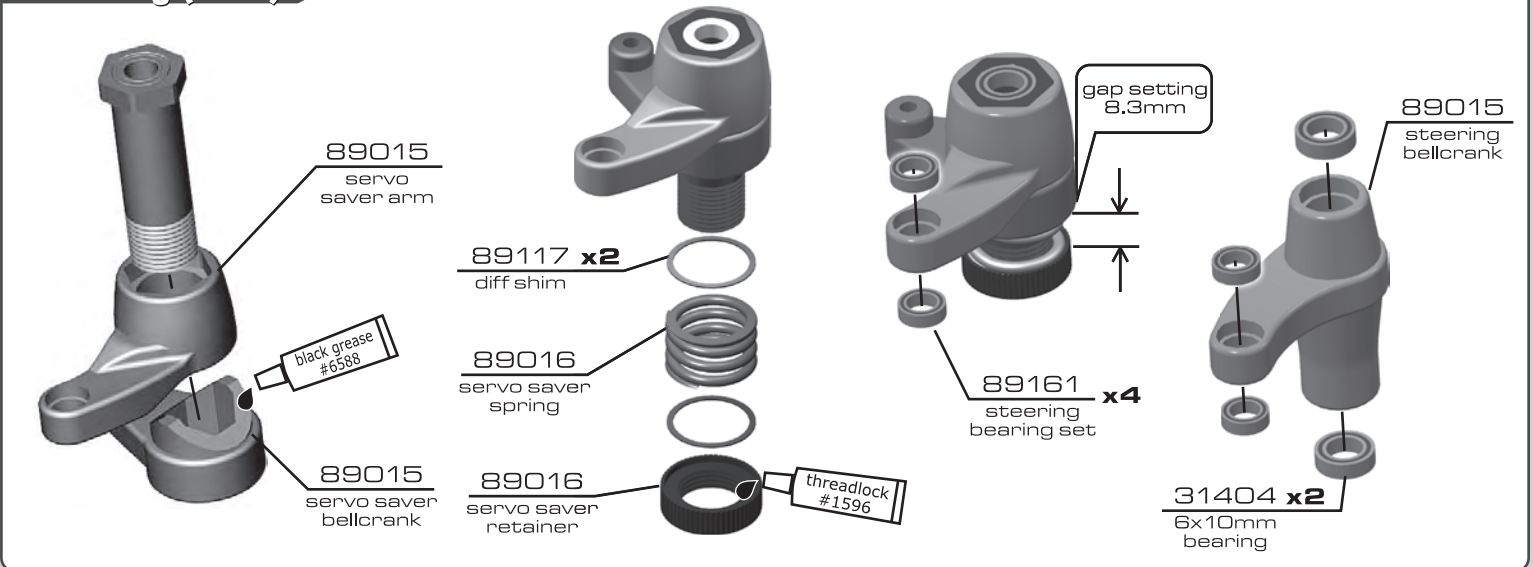

:: Steering (cont.)

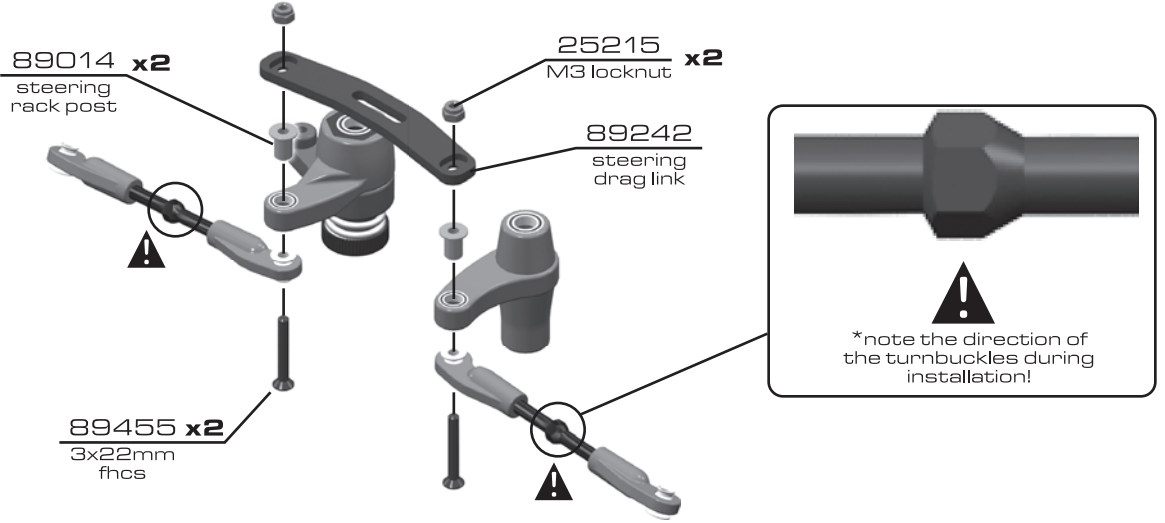

:: Steering (cont.)

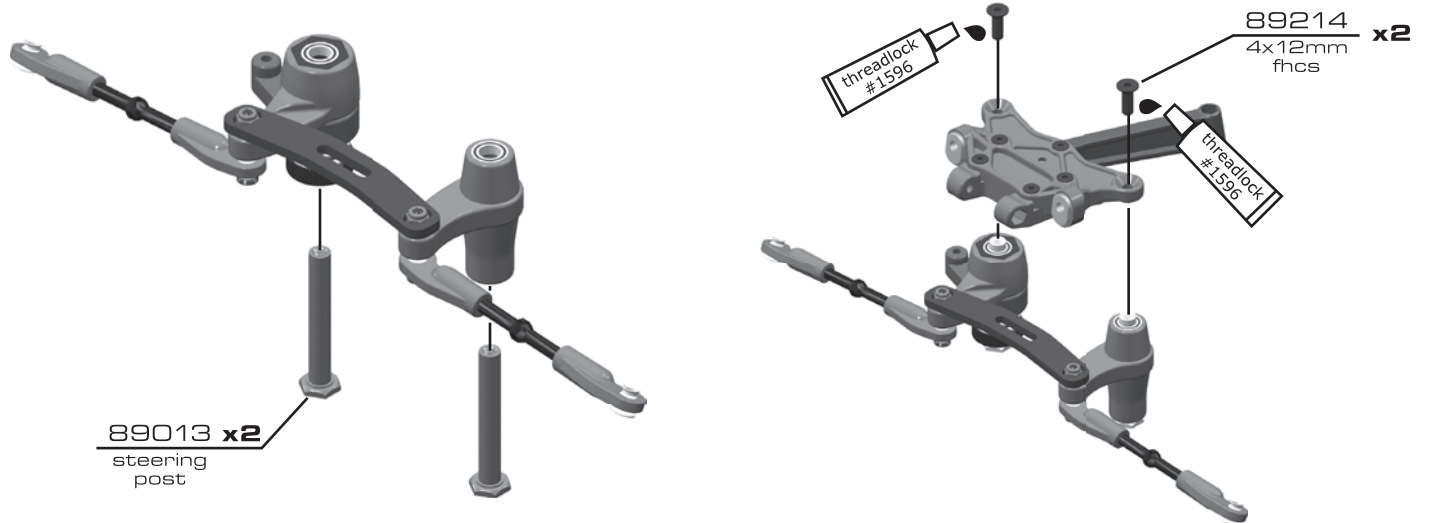

:: Front Gearbox

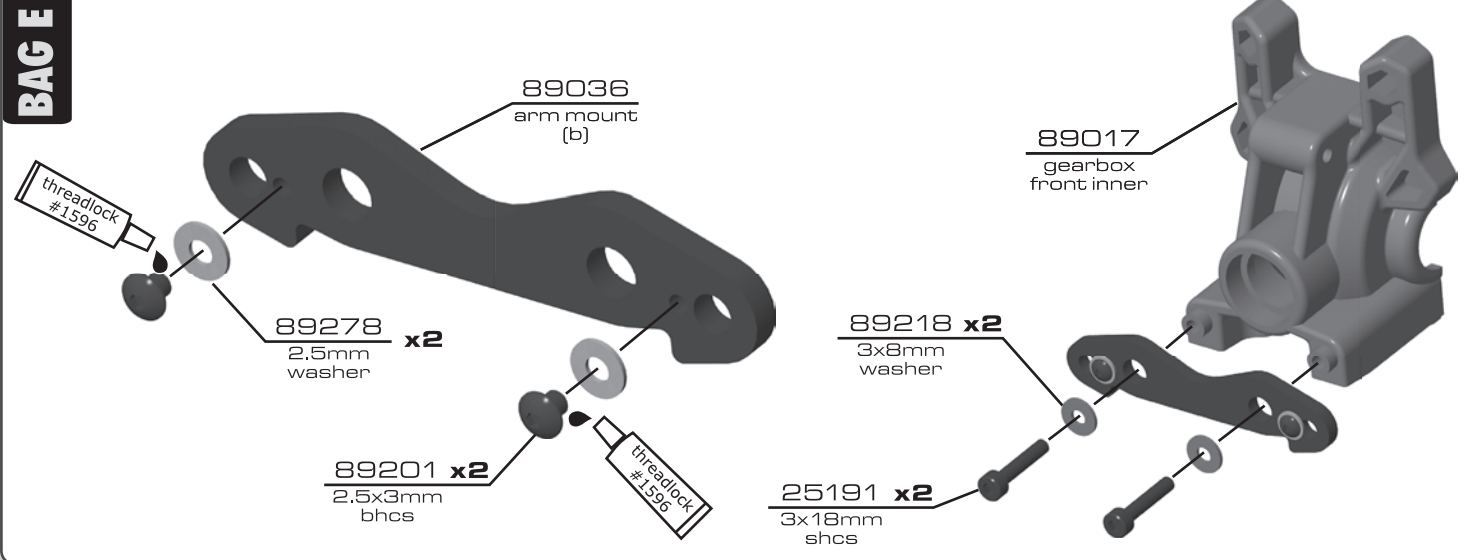

:: Front Gearbox (cont.)

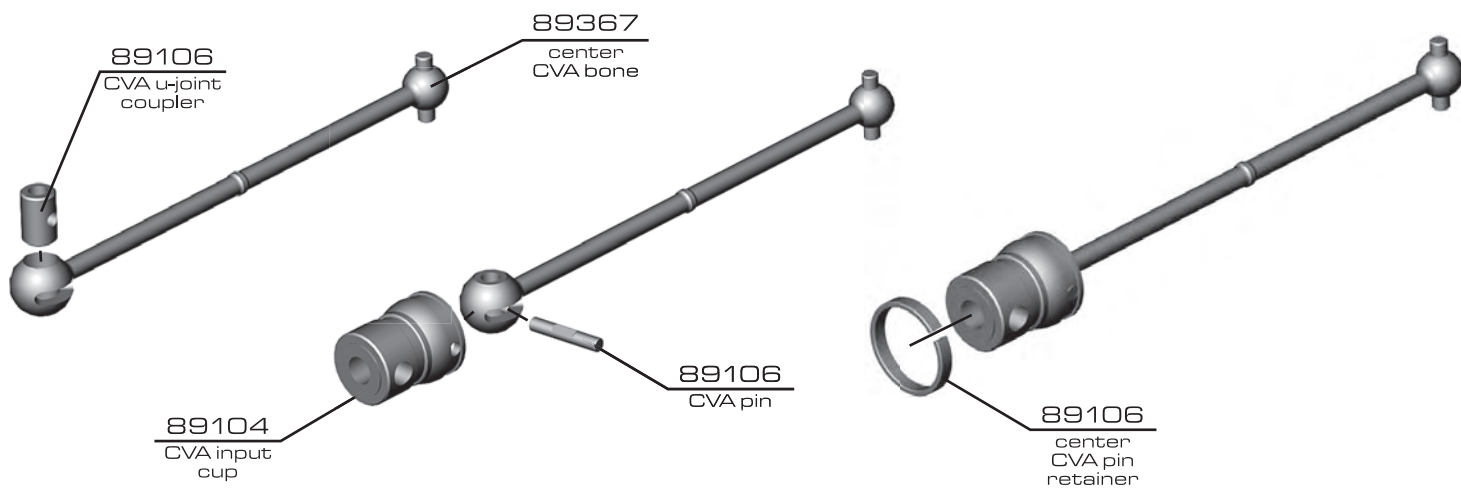

:: Front Gearbox (cont.)

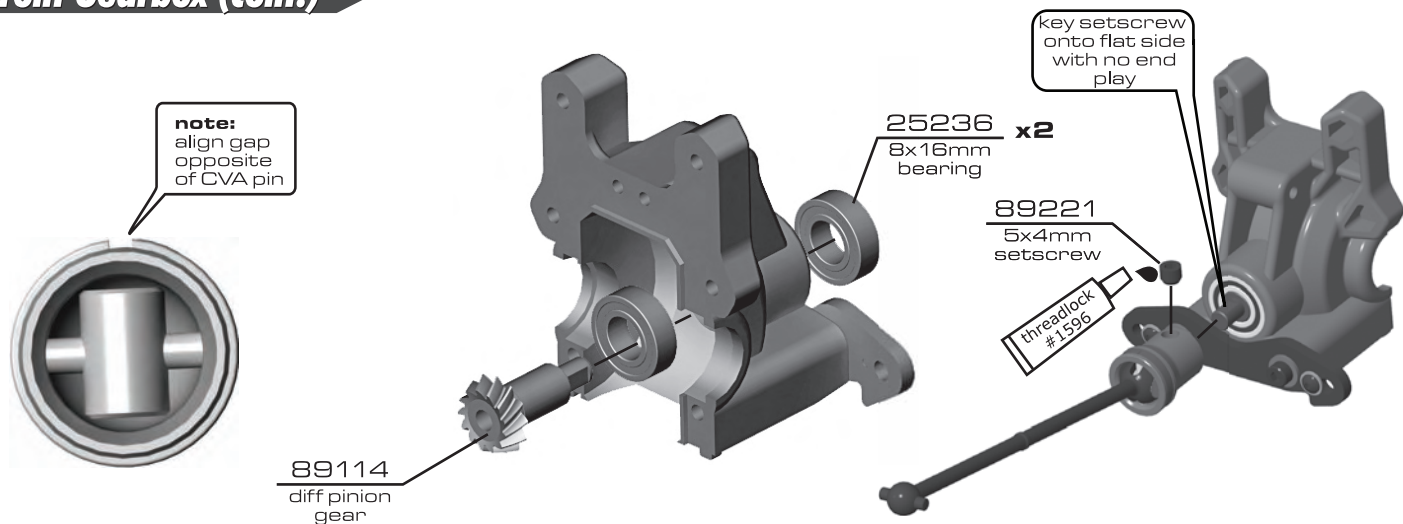

:: Front Gearbox (cont.)

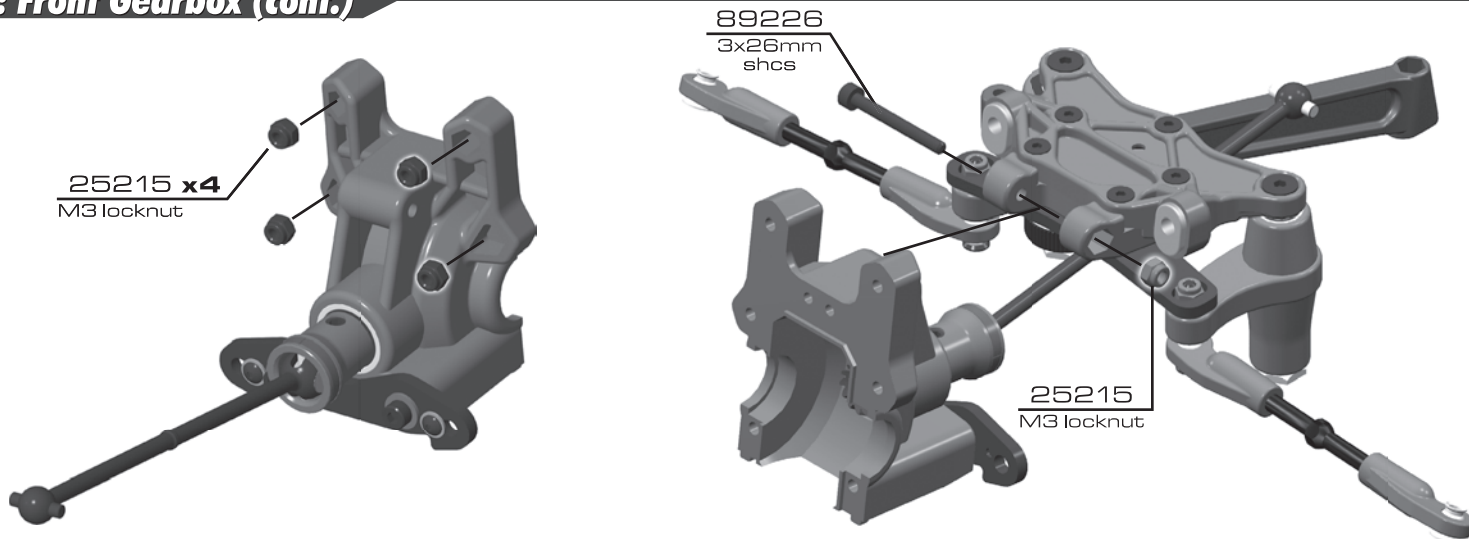

:: Front Gearbox (cont.)

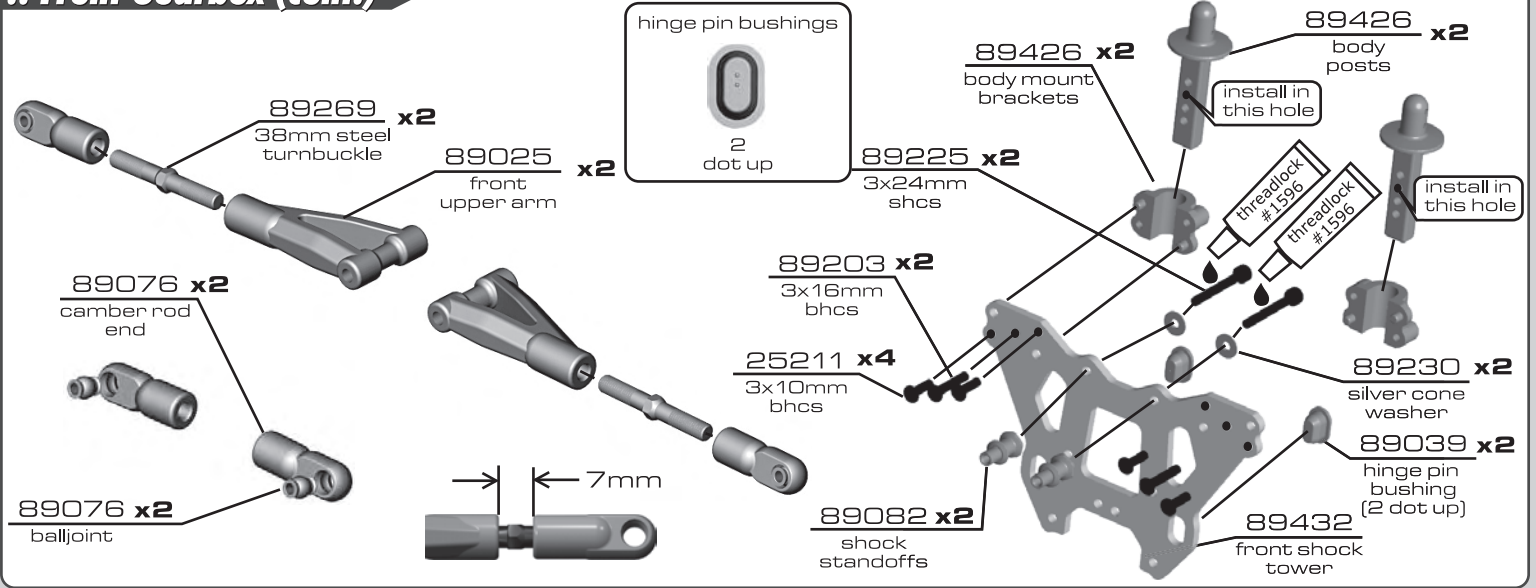

:: Front Gearbox (cont.)

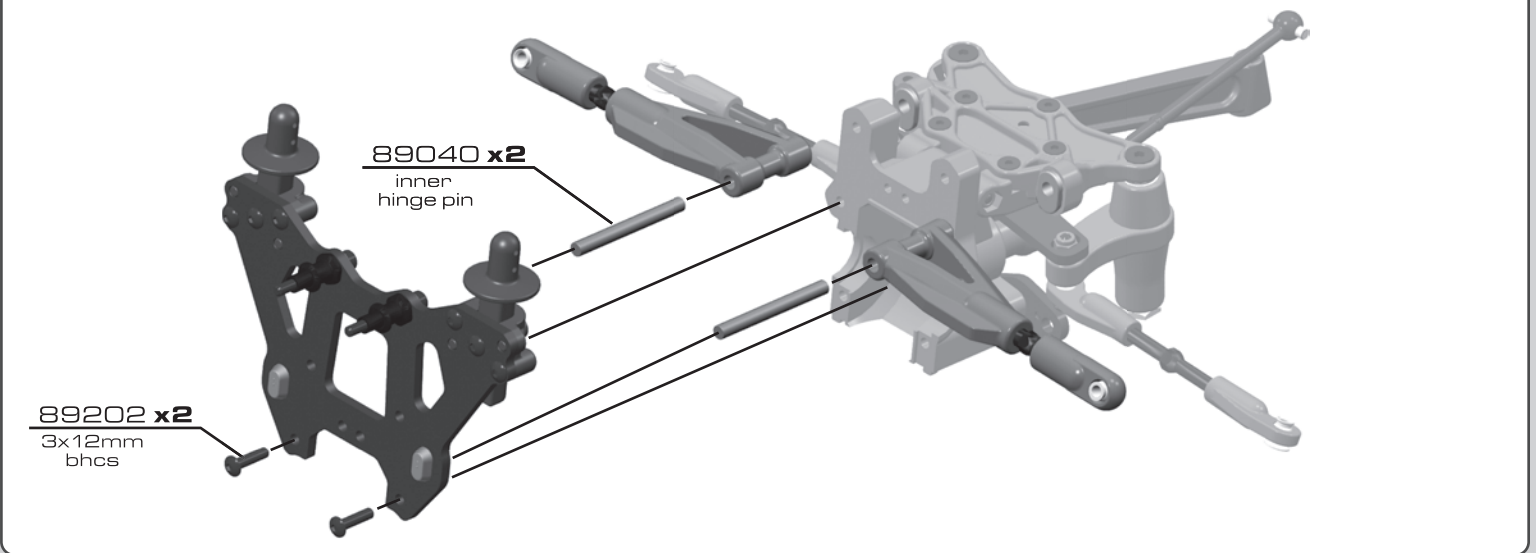

:: Front Gearbox (cont.)

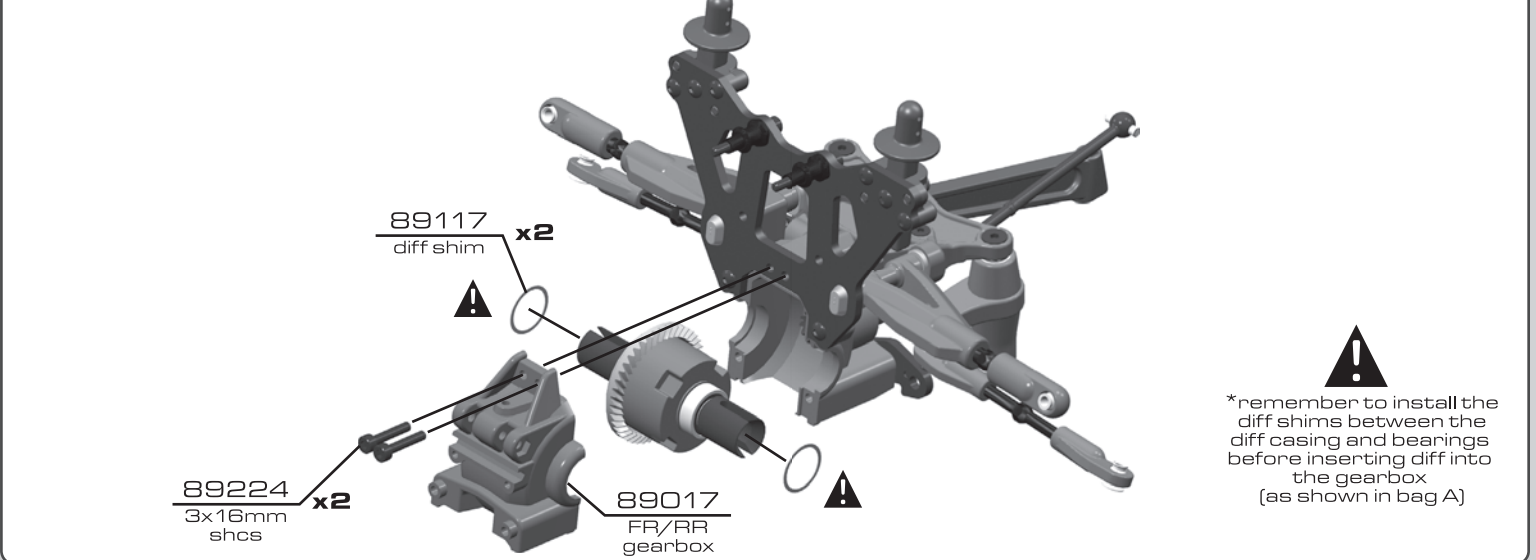

:: Suspension

BAG F

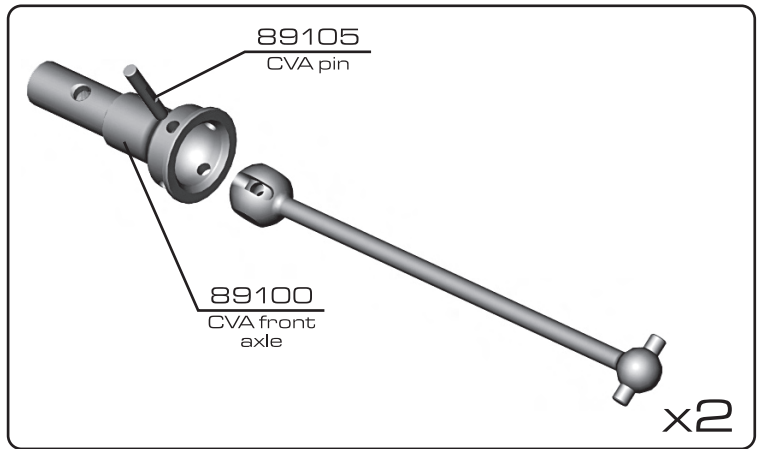
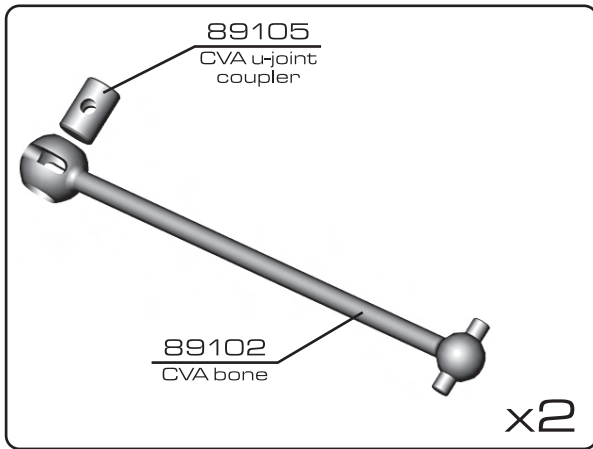

:: Suspension (cont.)

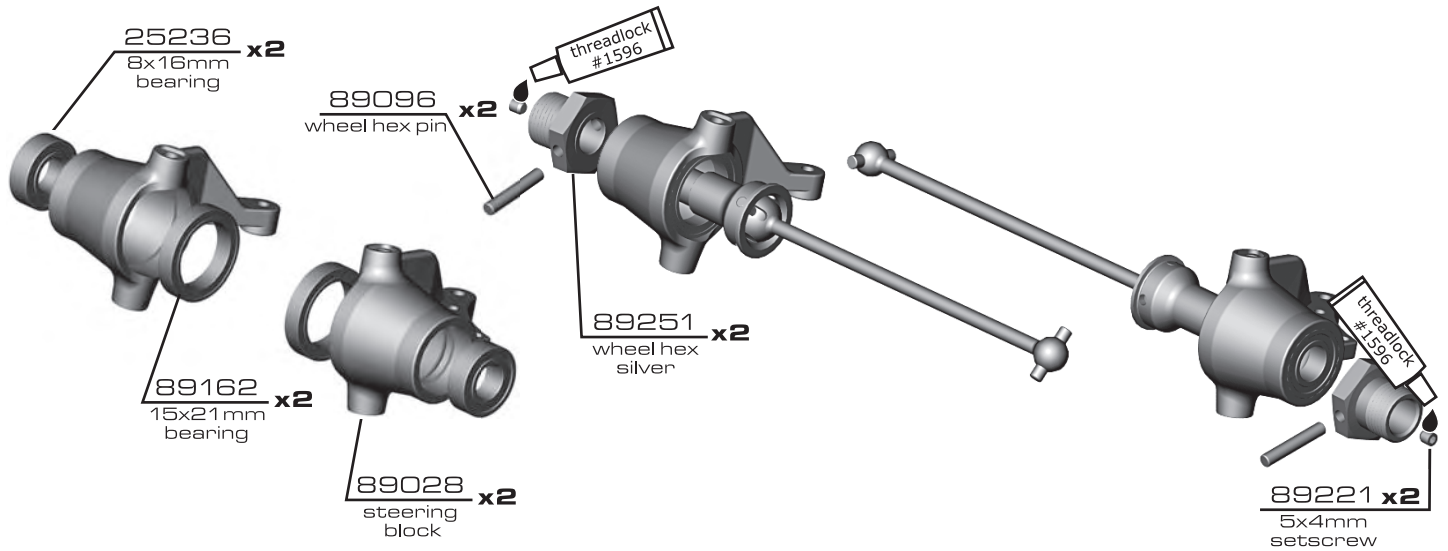

:: Suspension (cont.)

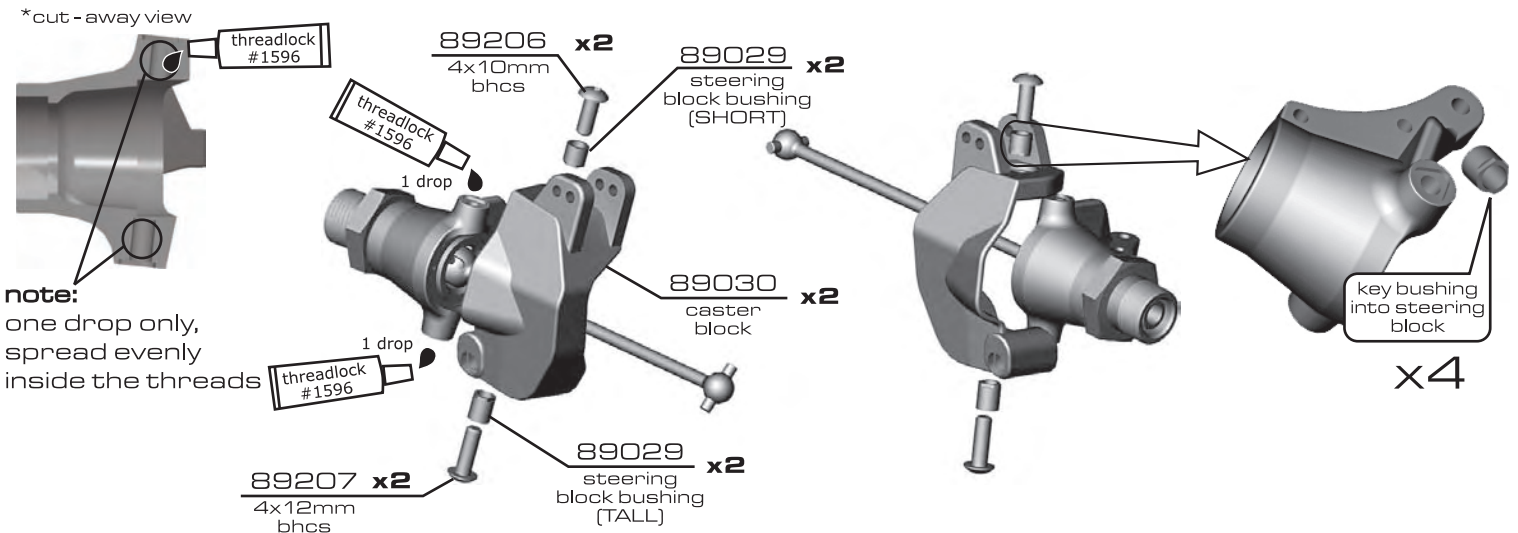

:: Suspension (cont.)

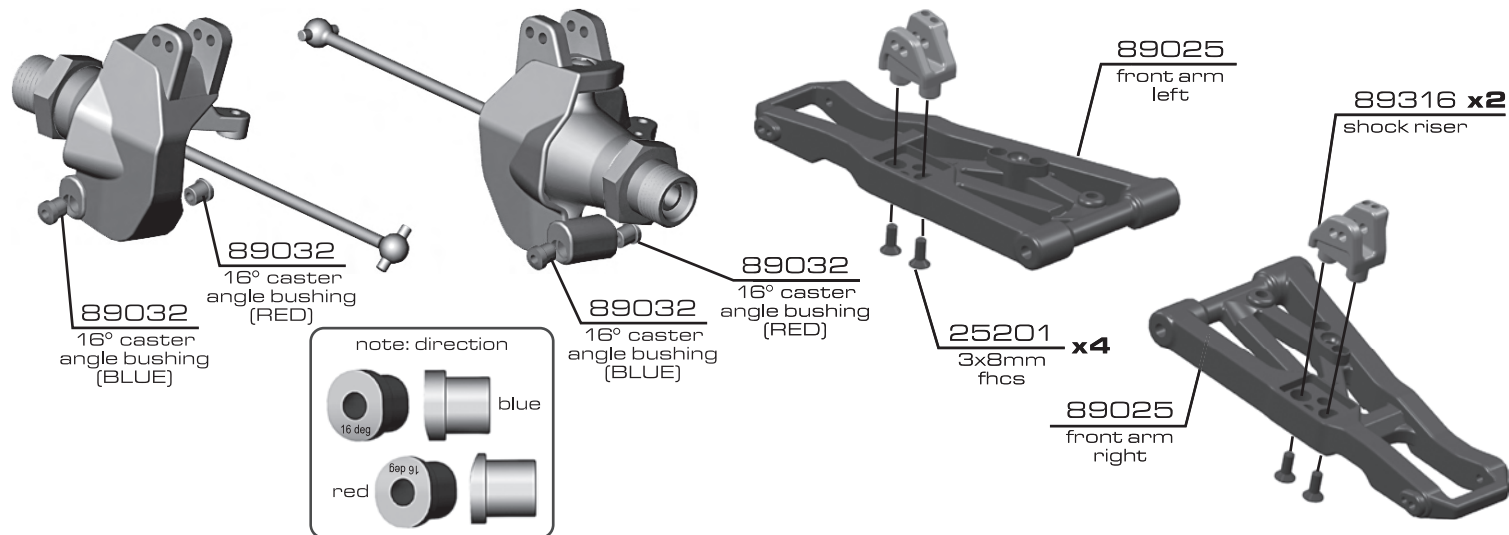

:: Suspension (cont.)

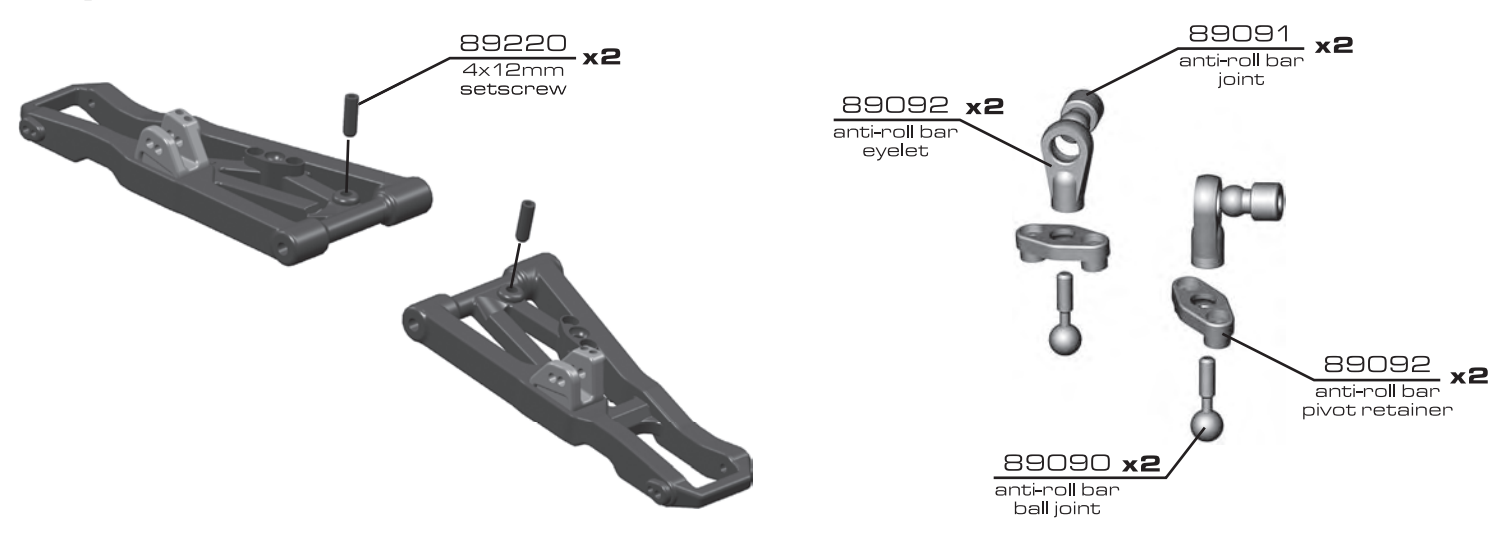

:: Suspension (cont.)

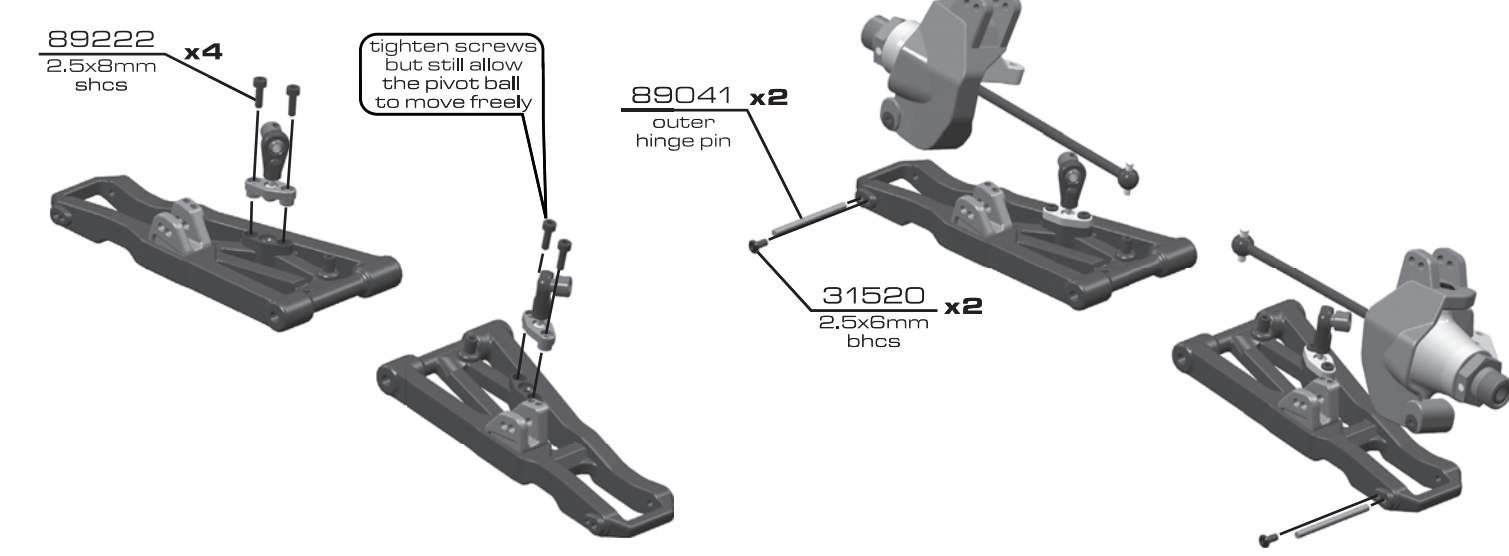

:: Suspension (cont.)

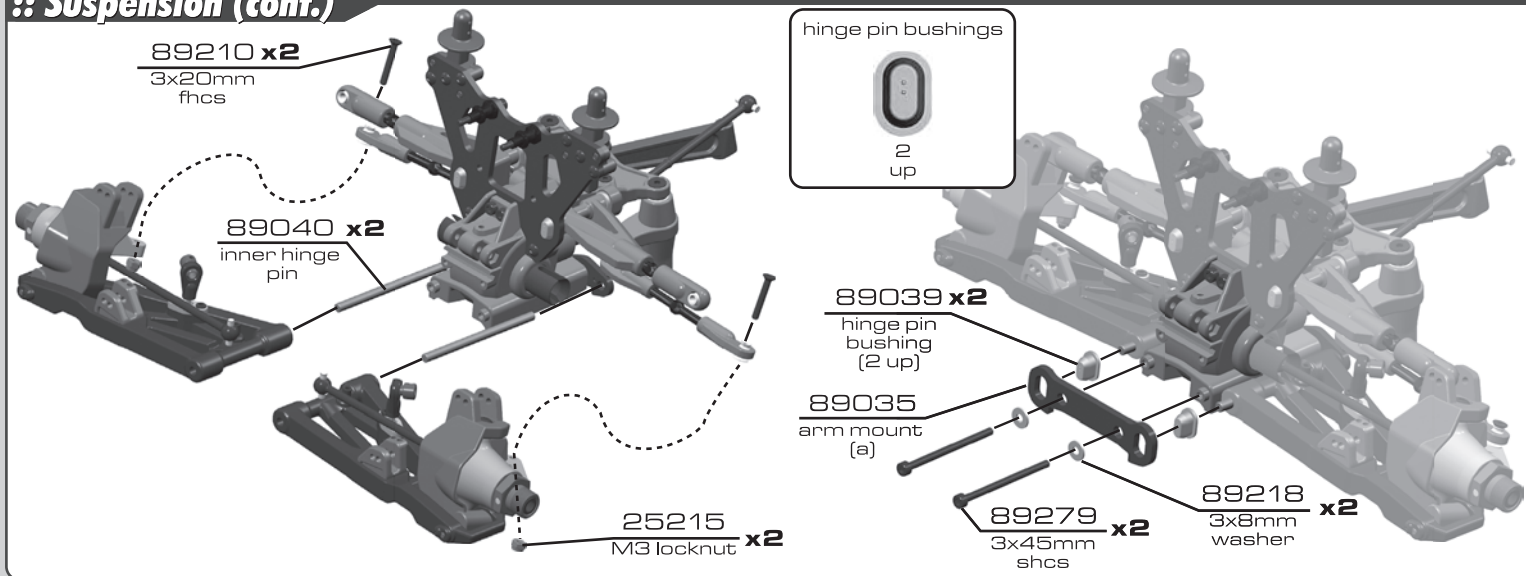

:: Suspension (cont.)

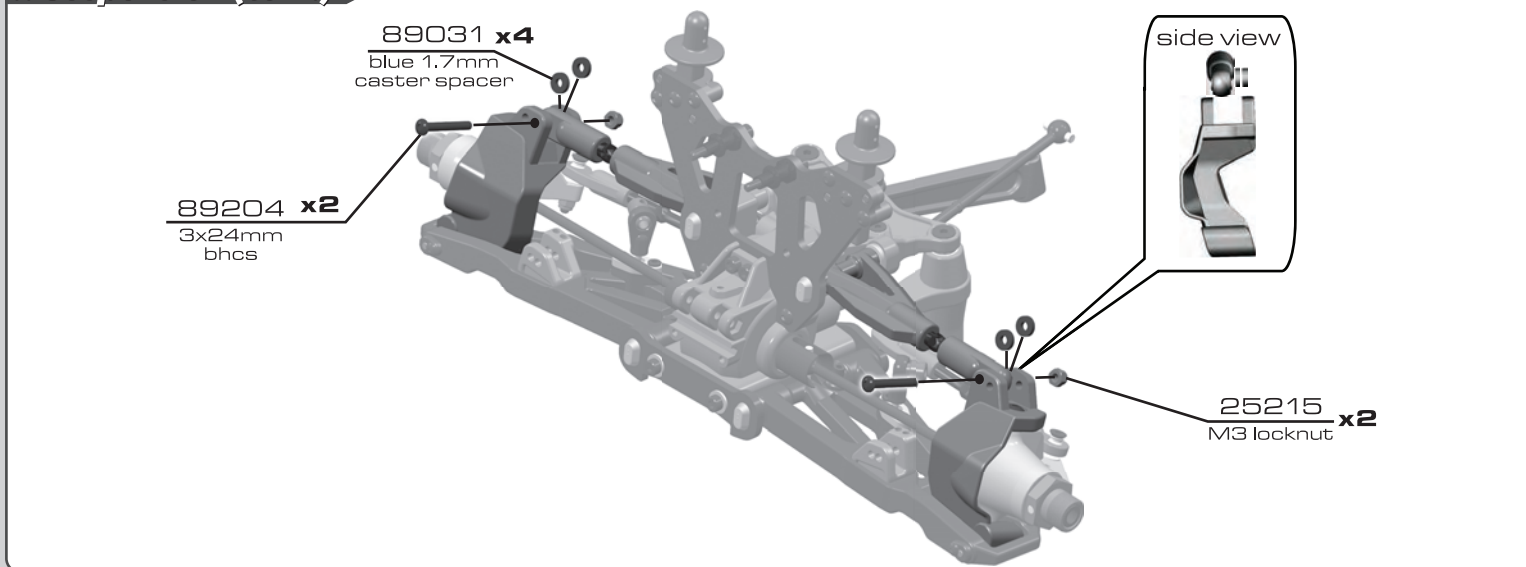

:: Suspension (cont.)

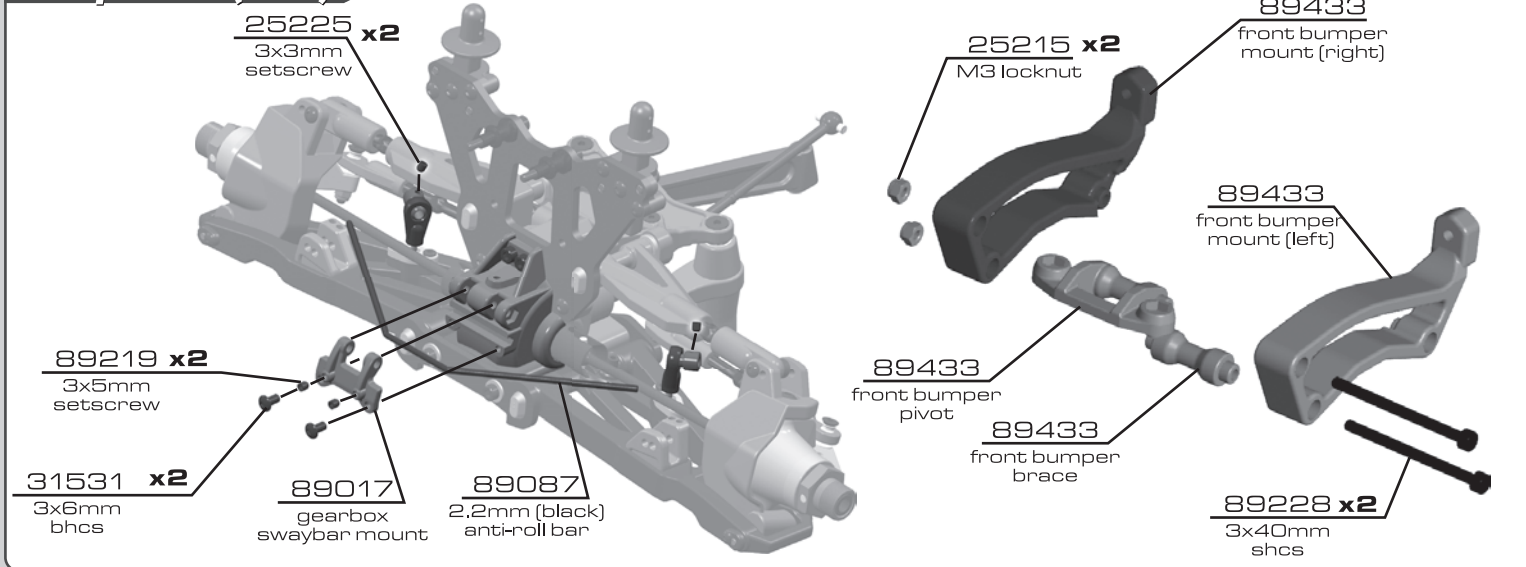

:: Suspension (cont.)

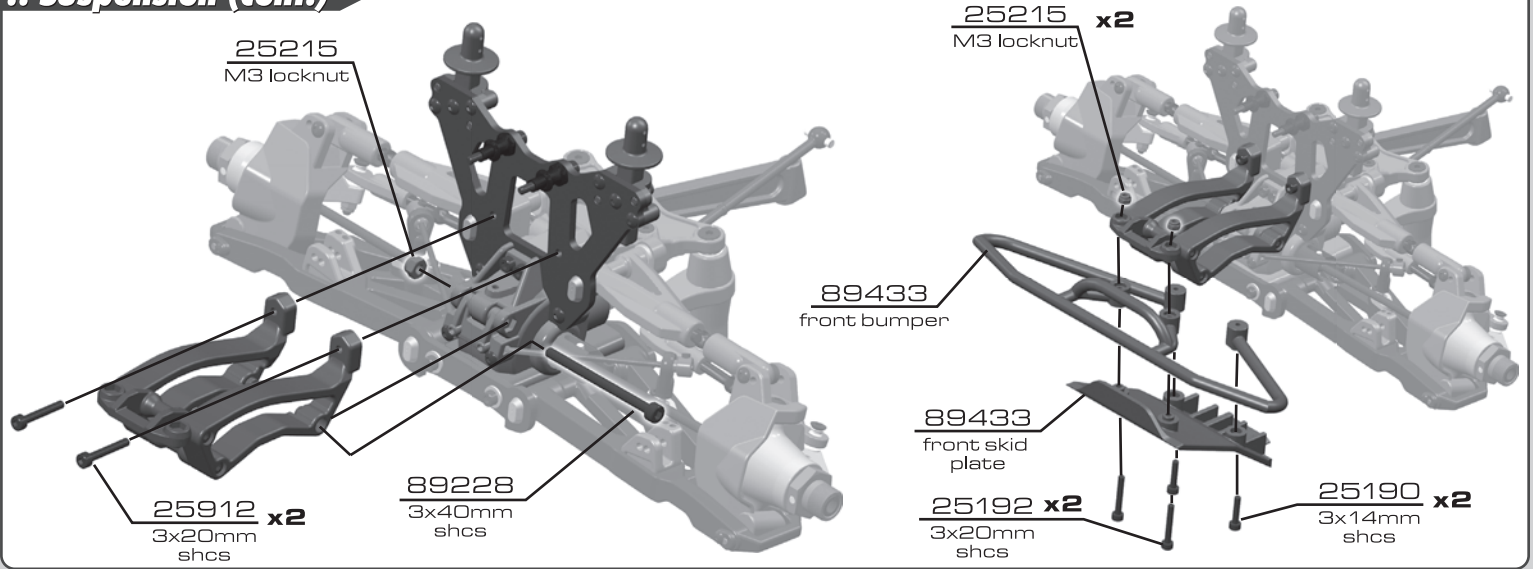

:: Suspension (cont.)

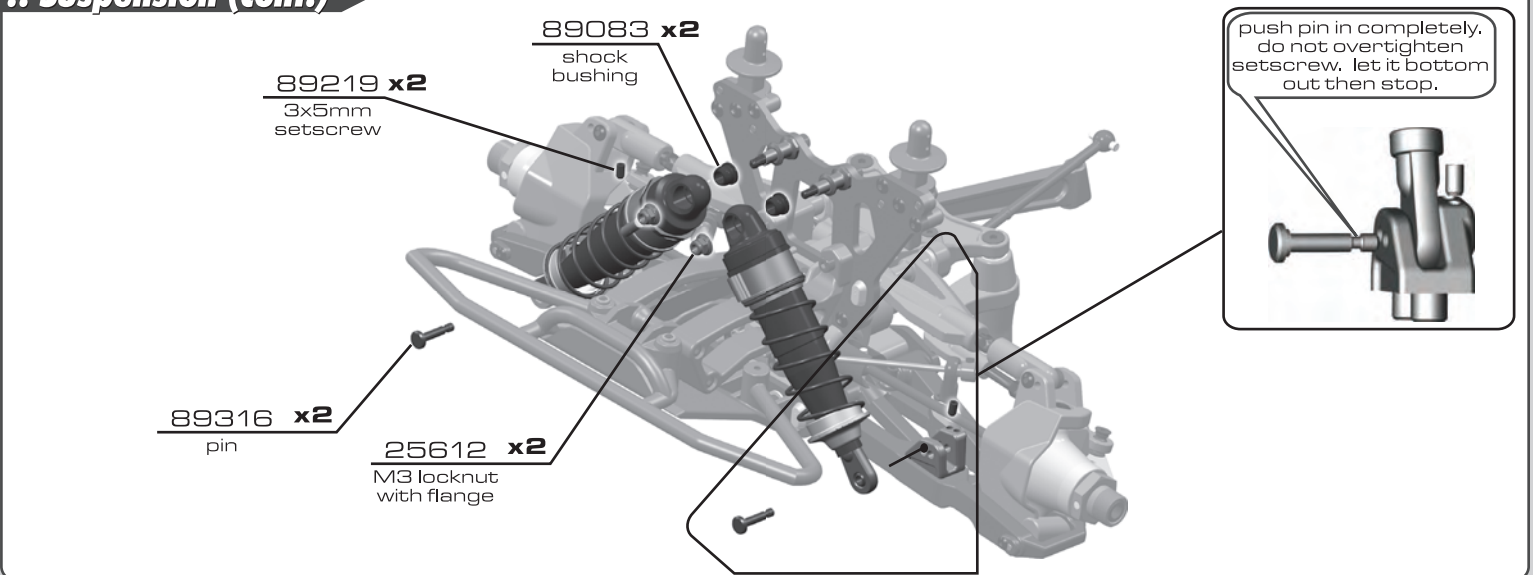

:: Rear Gearbox

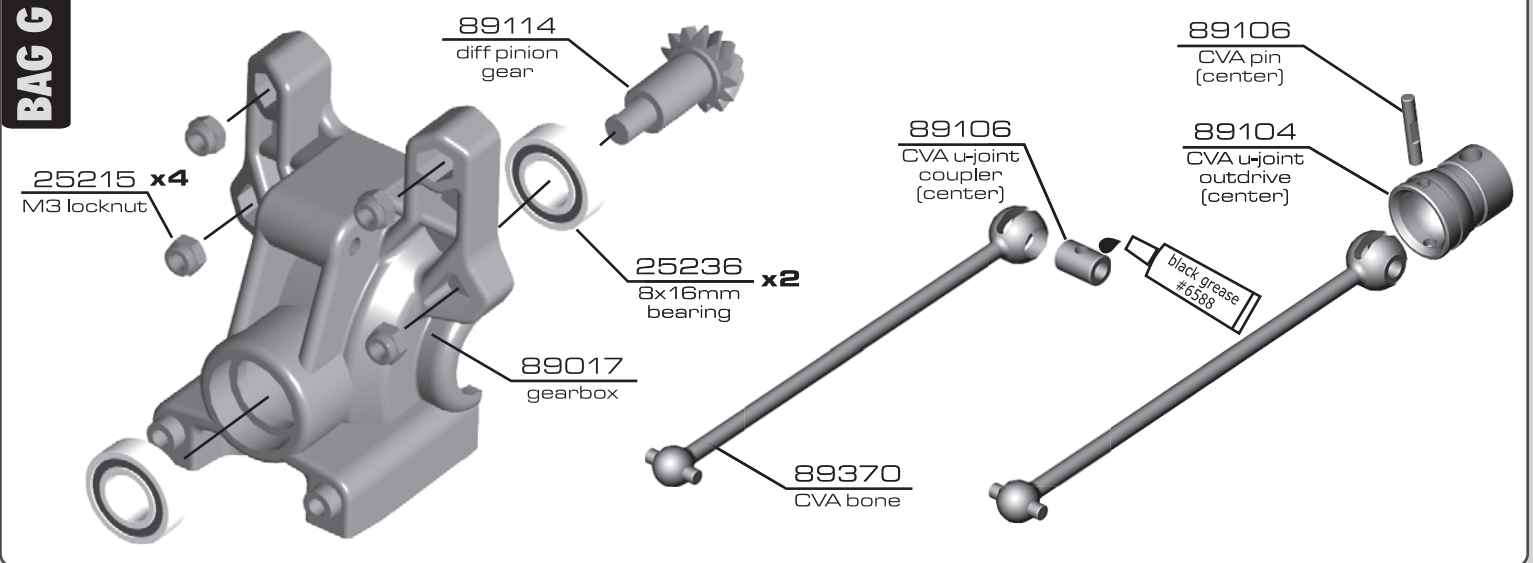

:: Rear Gearbox (cont.)

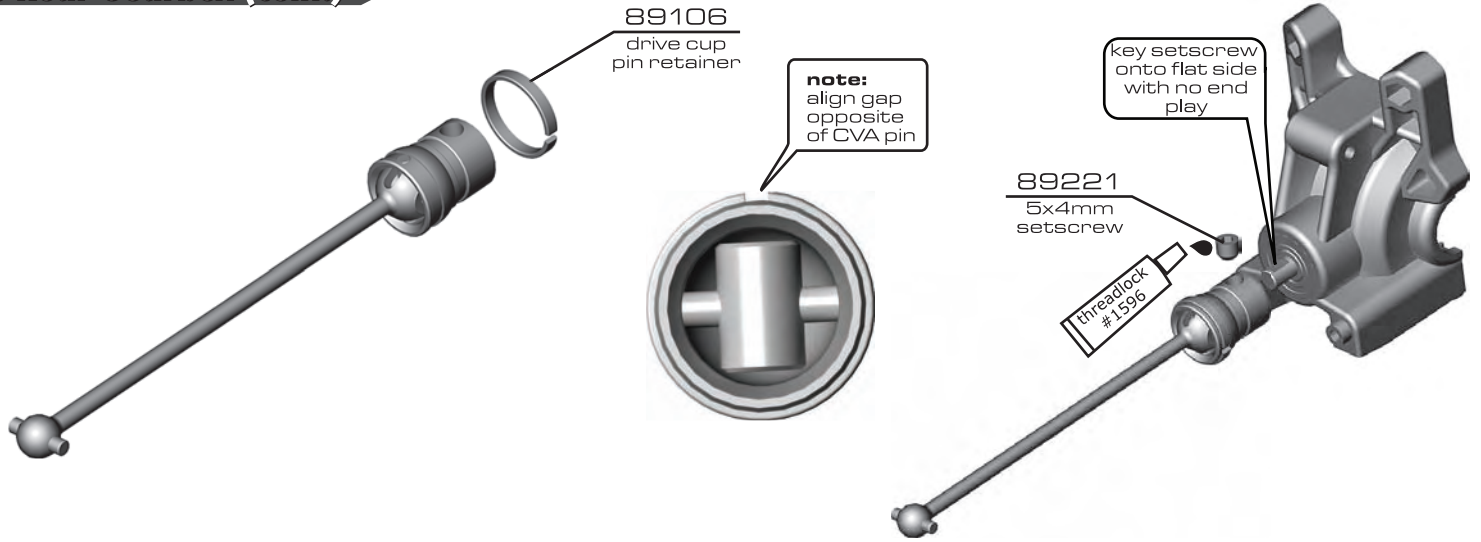

:: Rear Gearbox (cont.)

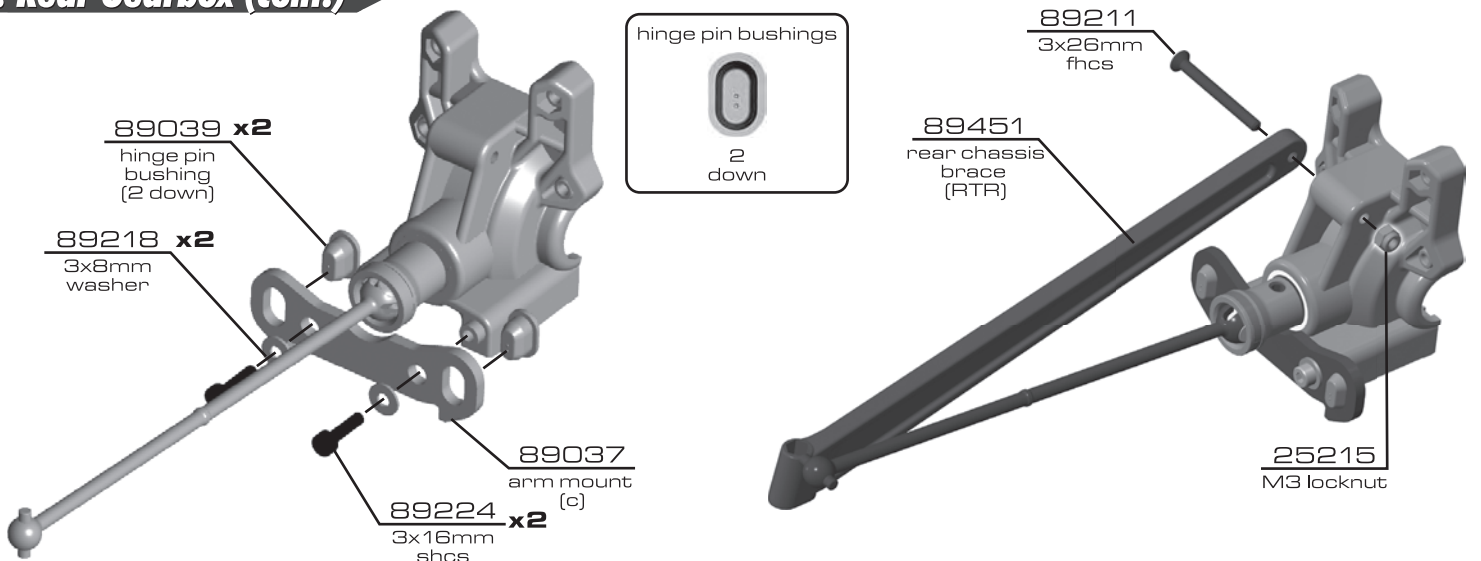

:: Rear Gearbox (cont.)

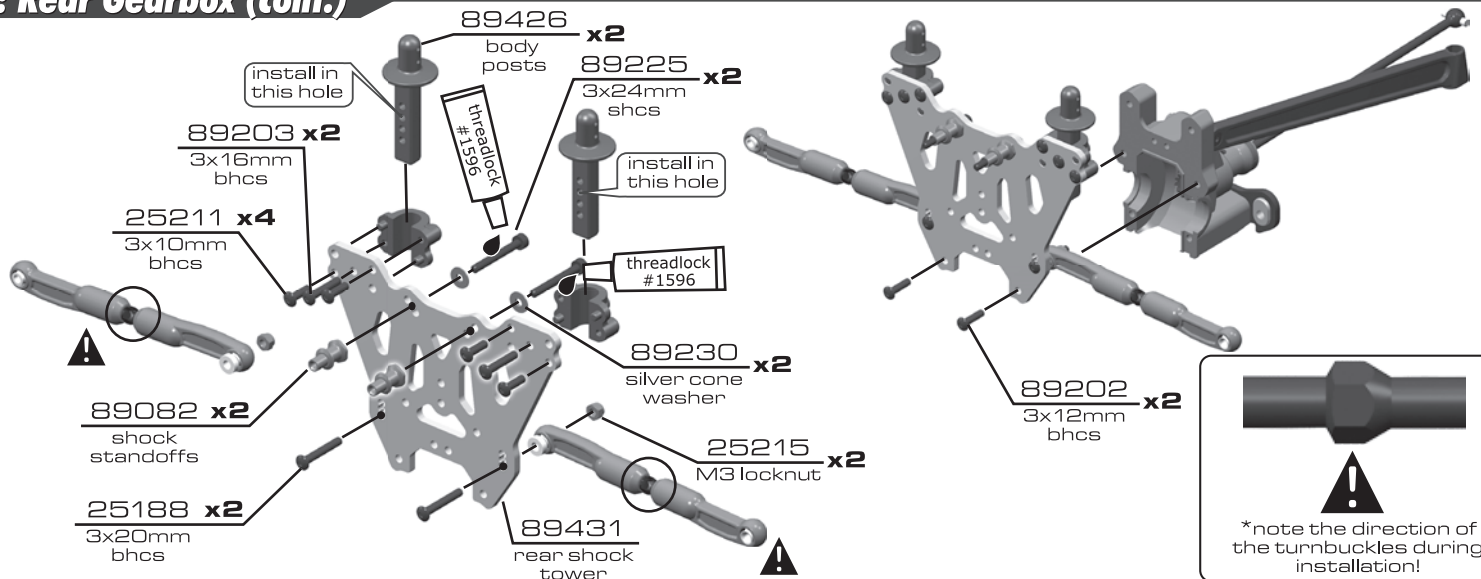

:: Rear Gearbox (cont.)

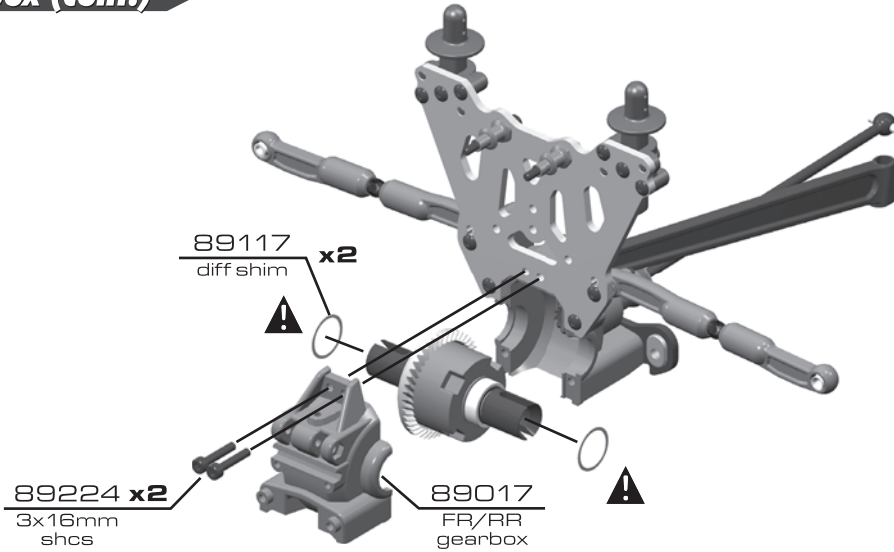

!
*remember to install the diff shims between the diff casing and bearings before inserting diff into the gearbox (as shown in bag A)

:: Suspension

BAG H

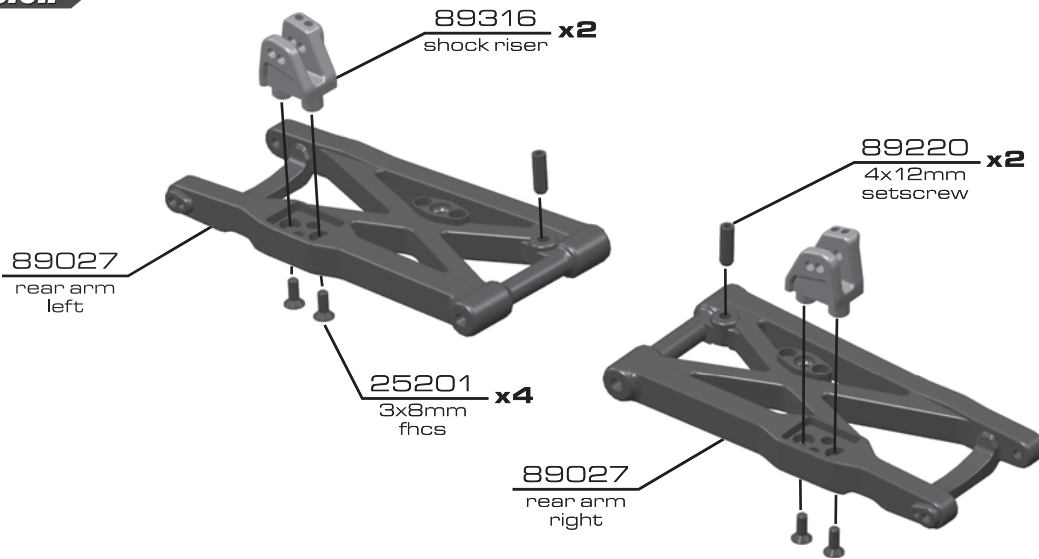

:: Suspension (cont.)

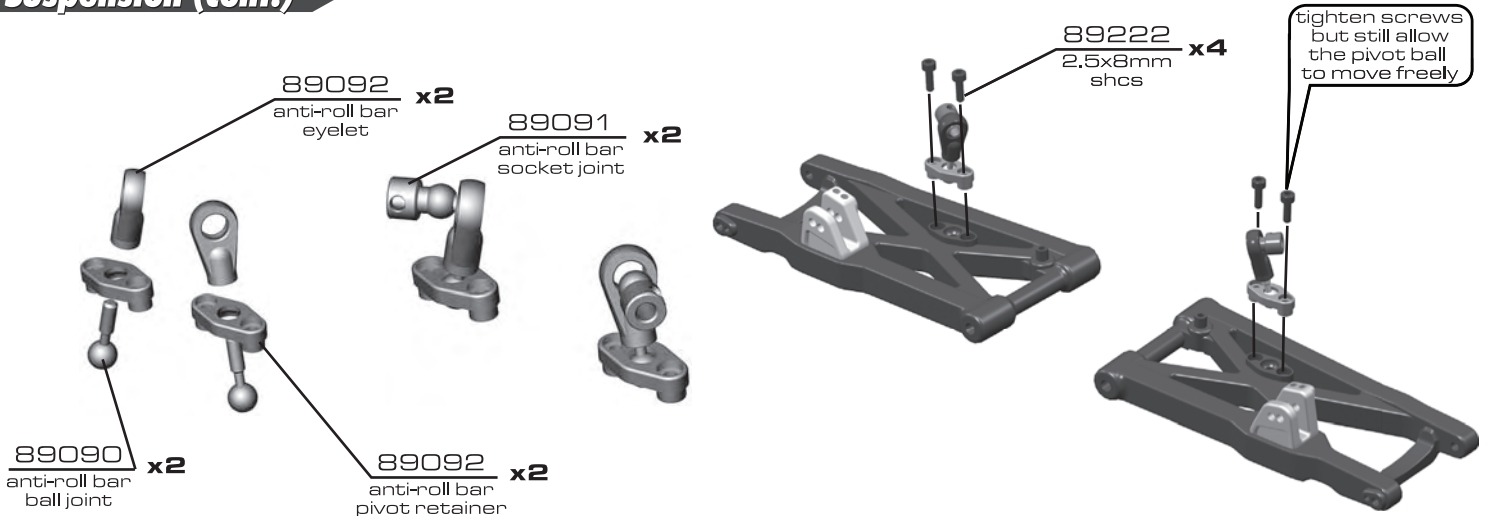

:: Suspension (cont.)

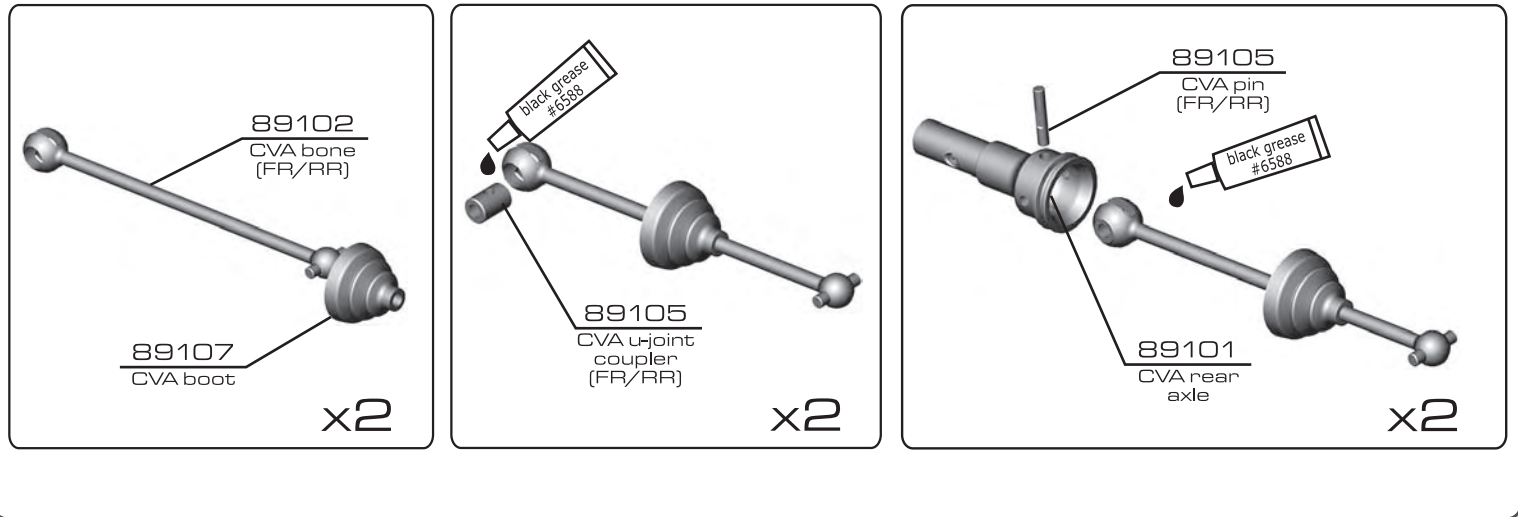

:: Suspension (cont.)

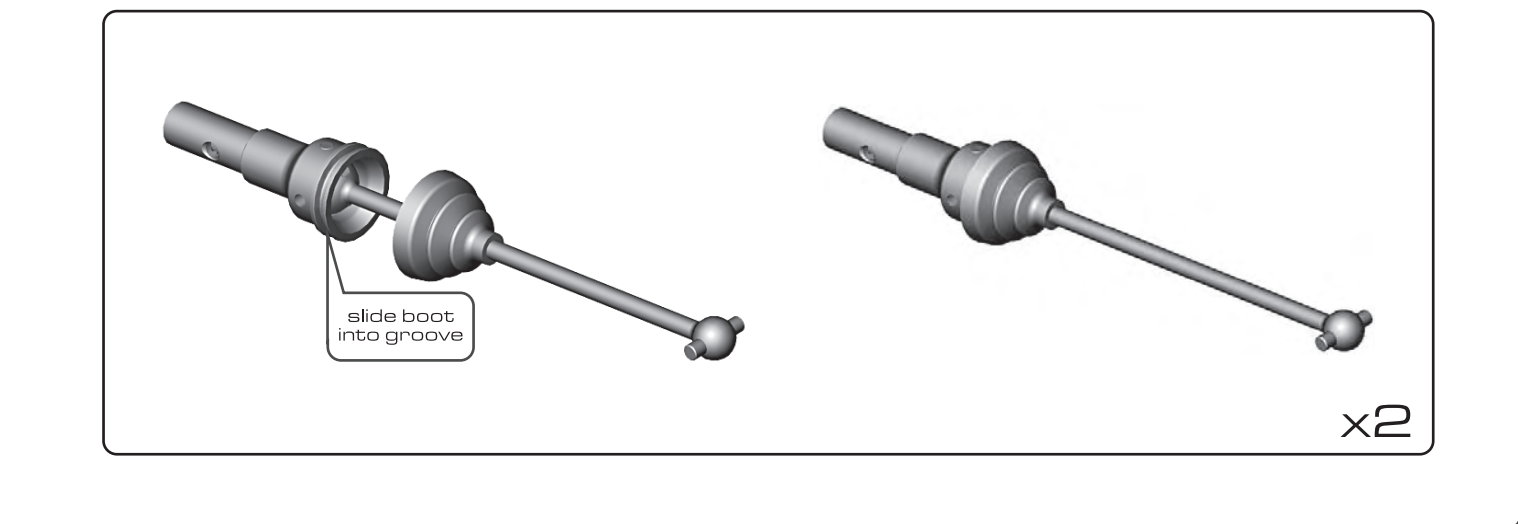

:: Suspension (cont.)

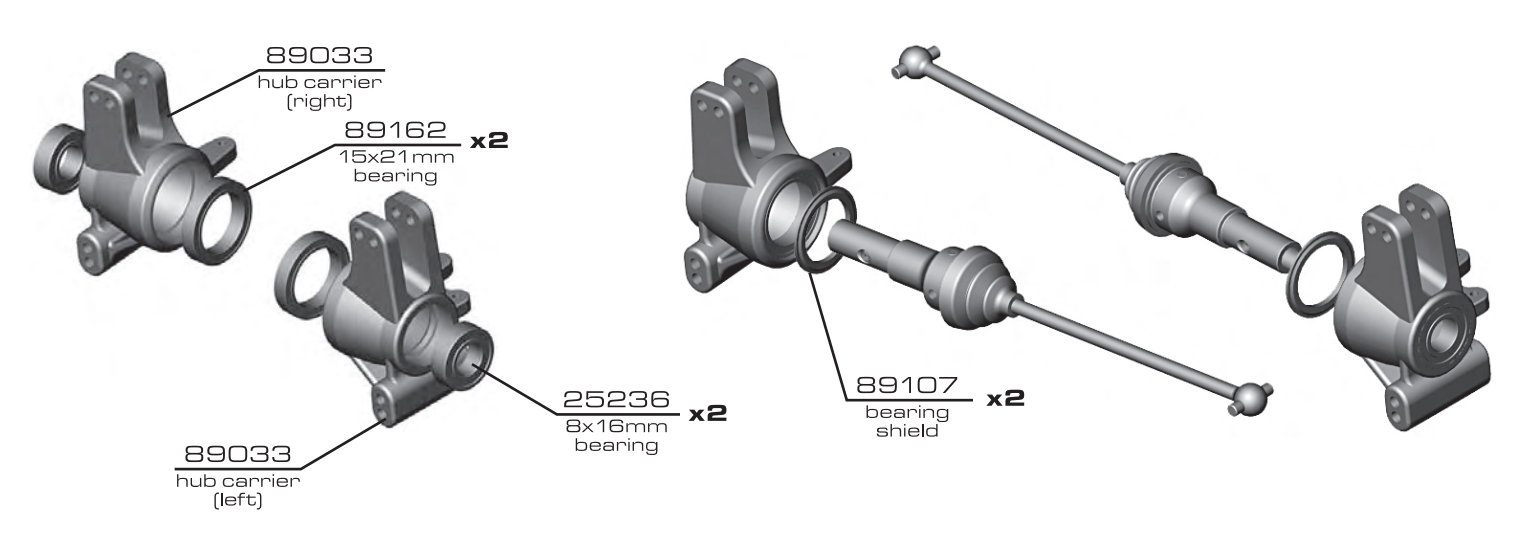

:: Suspension (cont.)

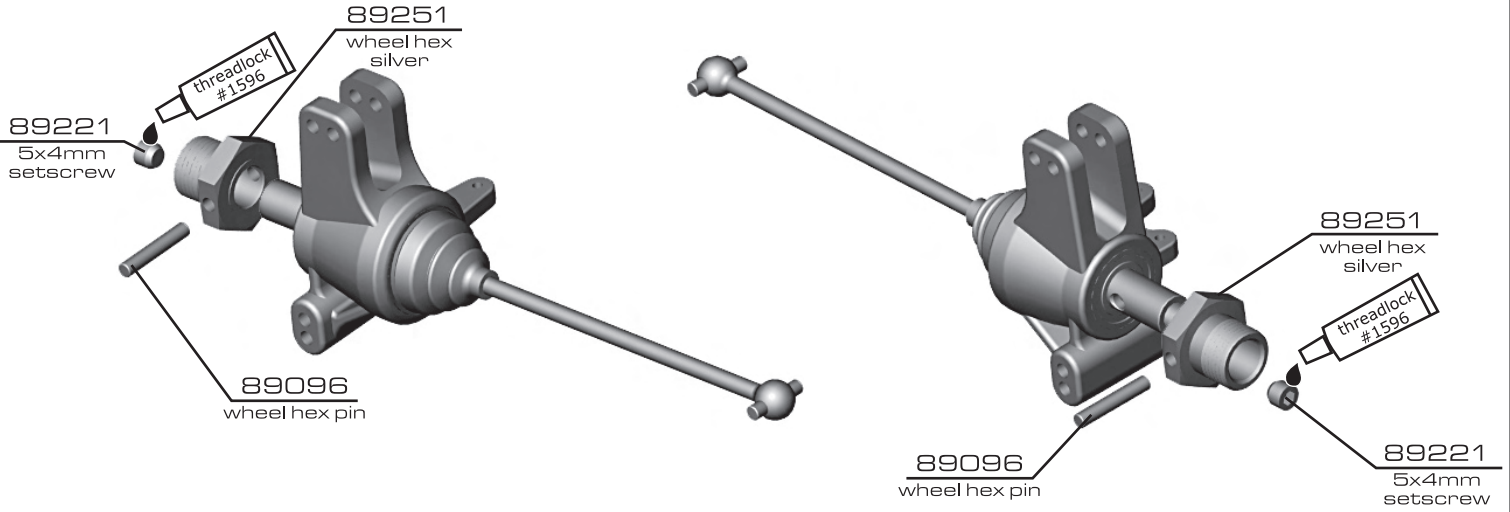

:: Suspension (cont.)

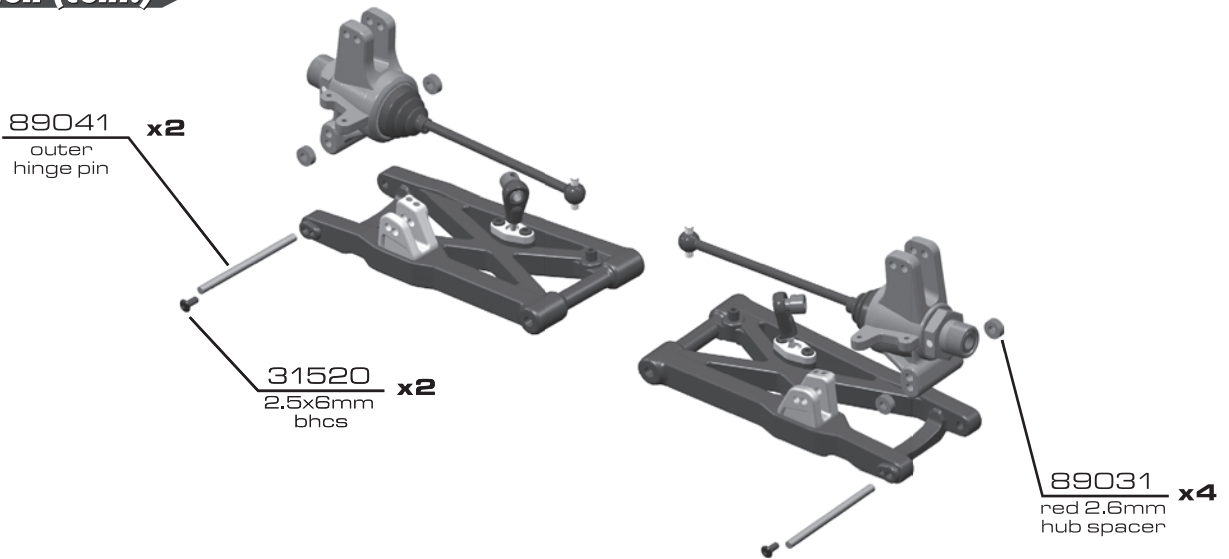

:: Suspension (cont.)

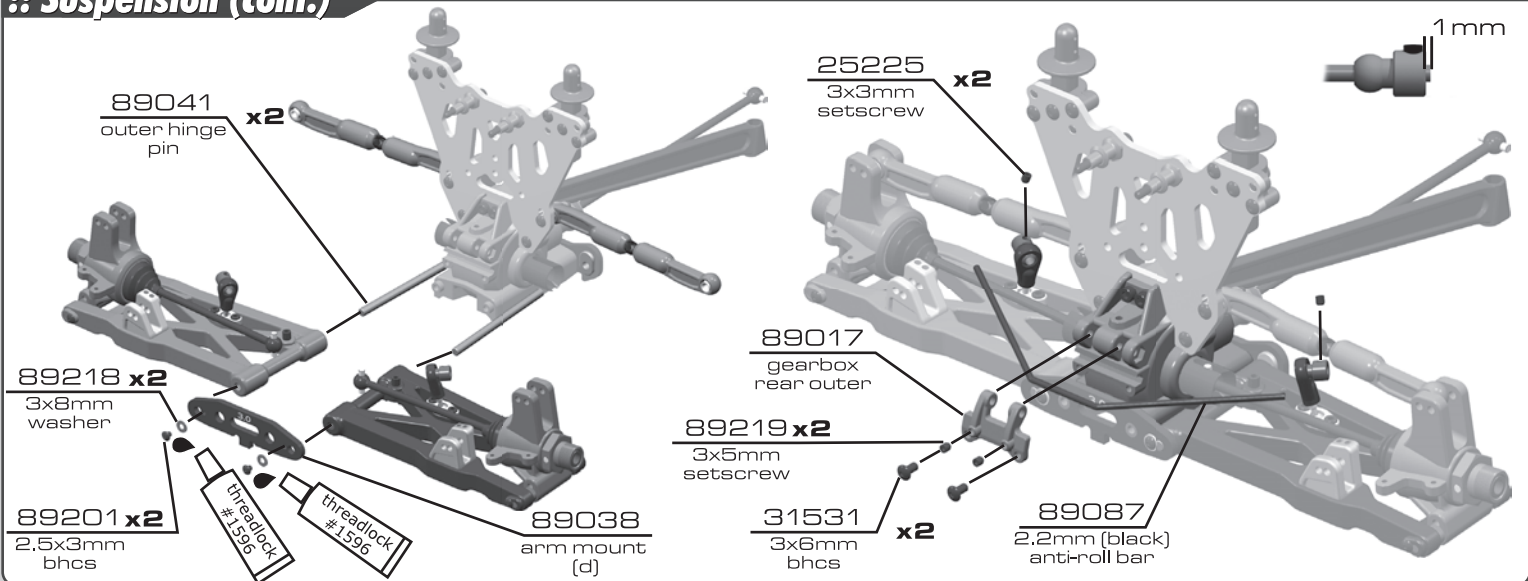

:: Suspension (cont.)

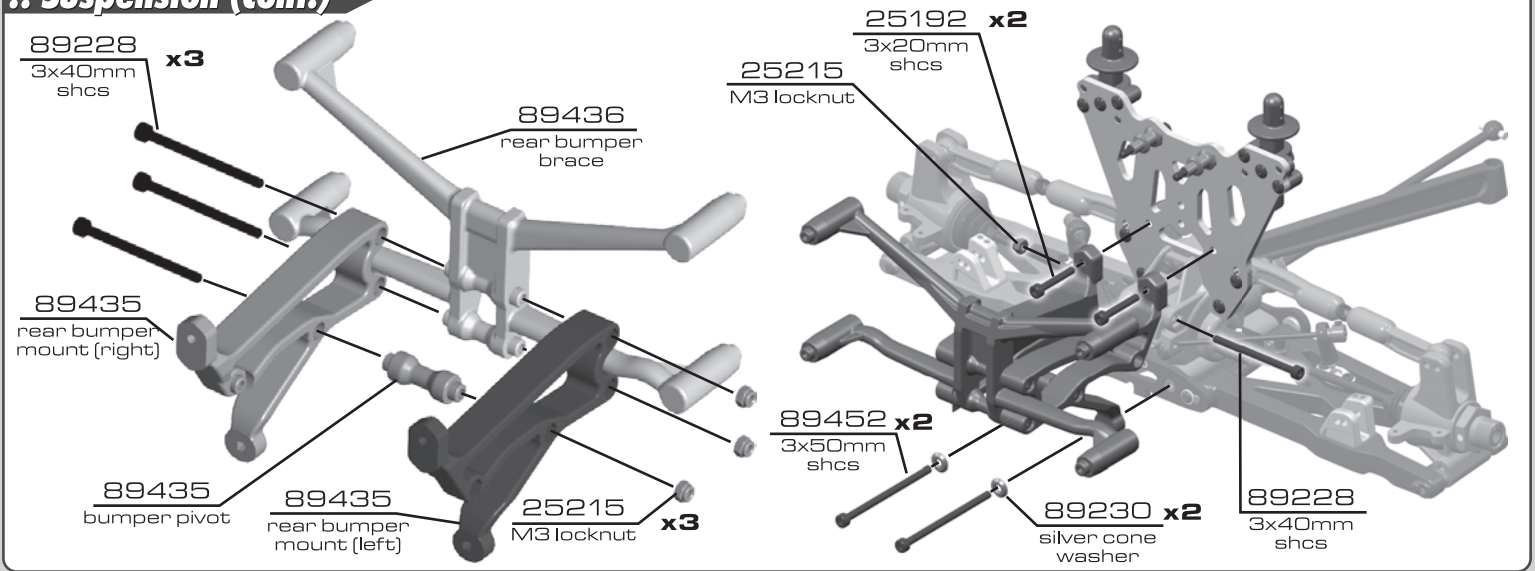

:: Suspension (cont.)

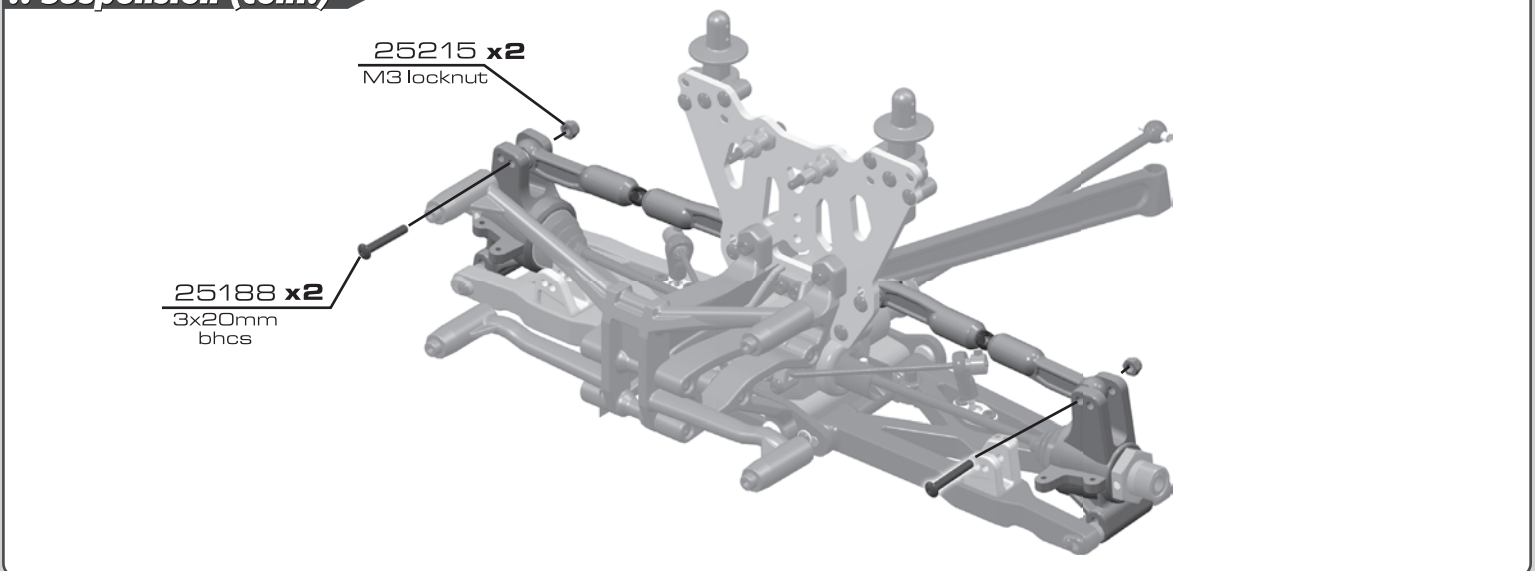

:: Suspension (cont.)

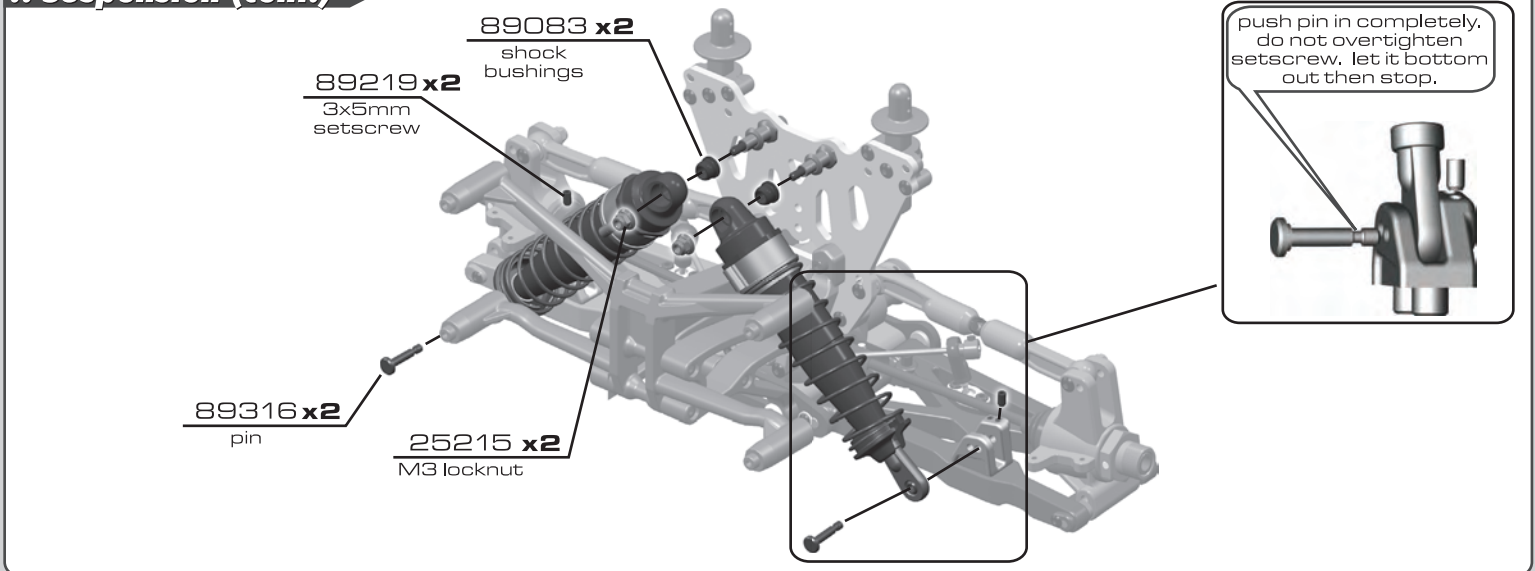

:: Suspension (cont.)

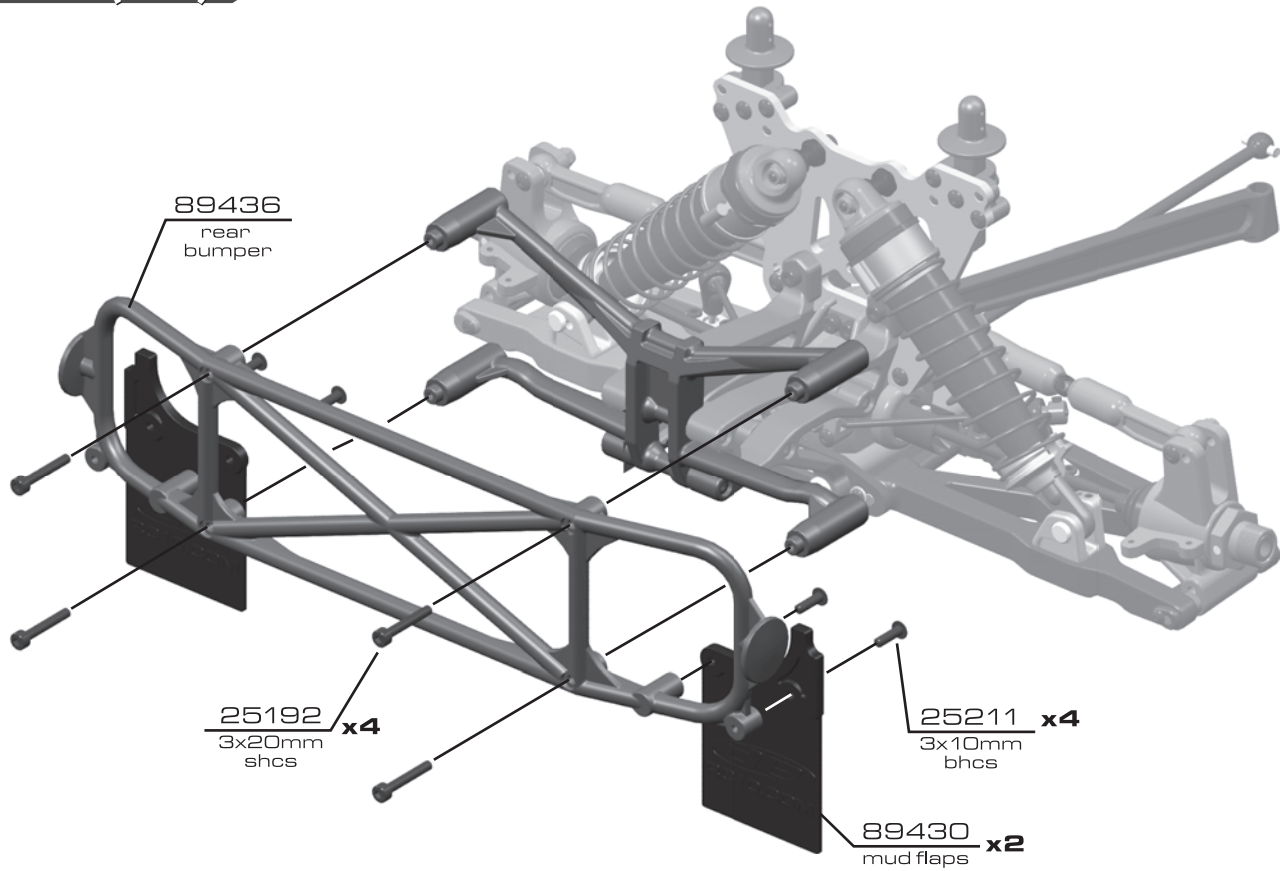

:: Chassis Assembly

BAG I

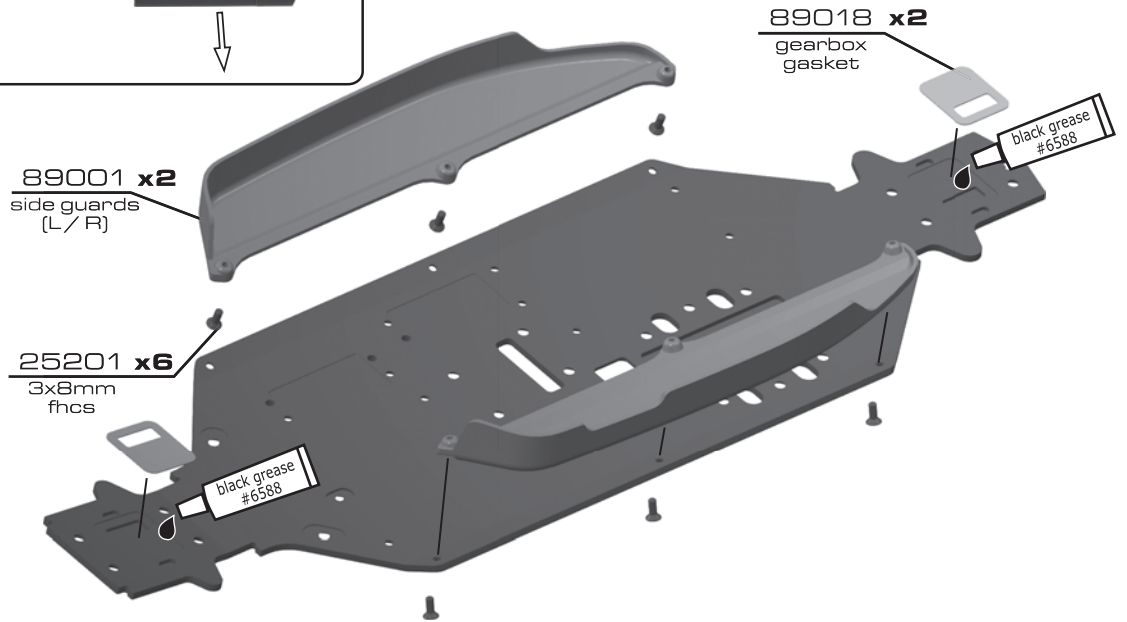
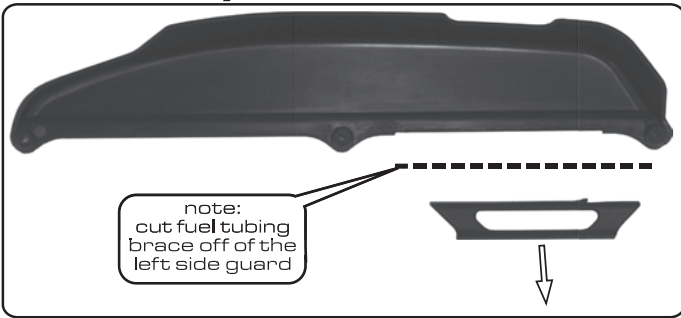

:: Chassis Assembly (cont.)

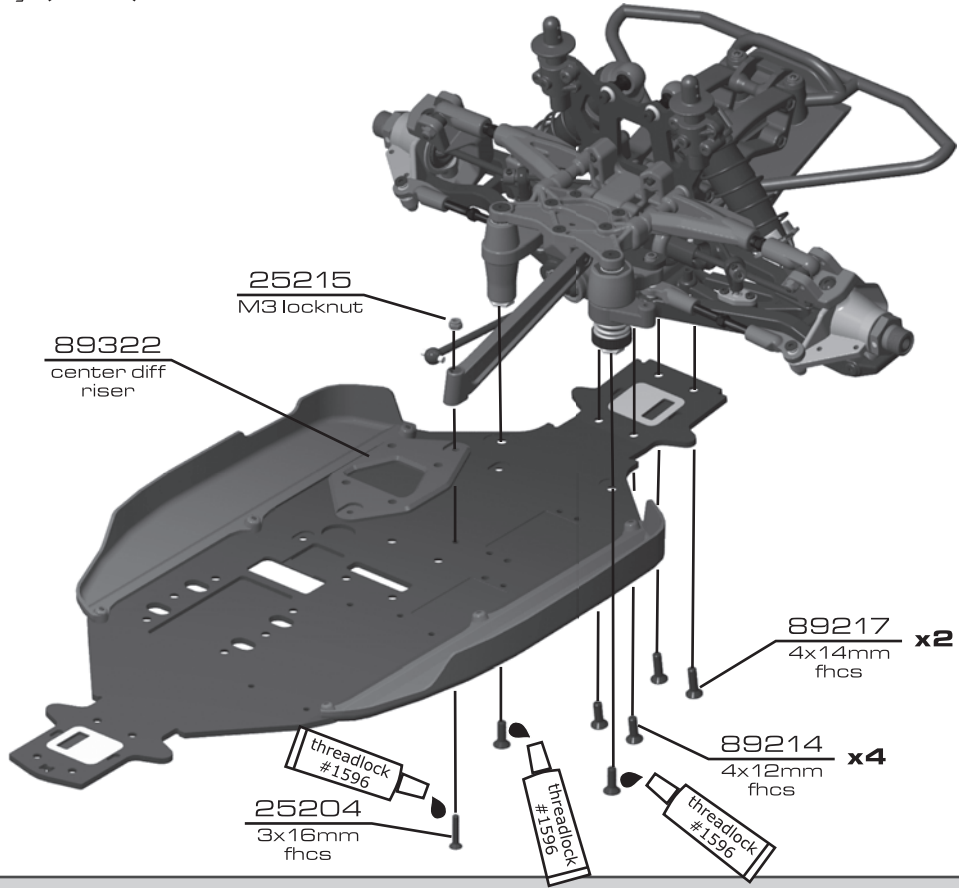

:: Chassis Assembly (cont.)

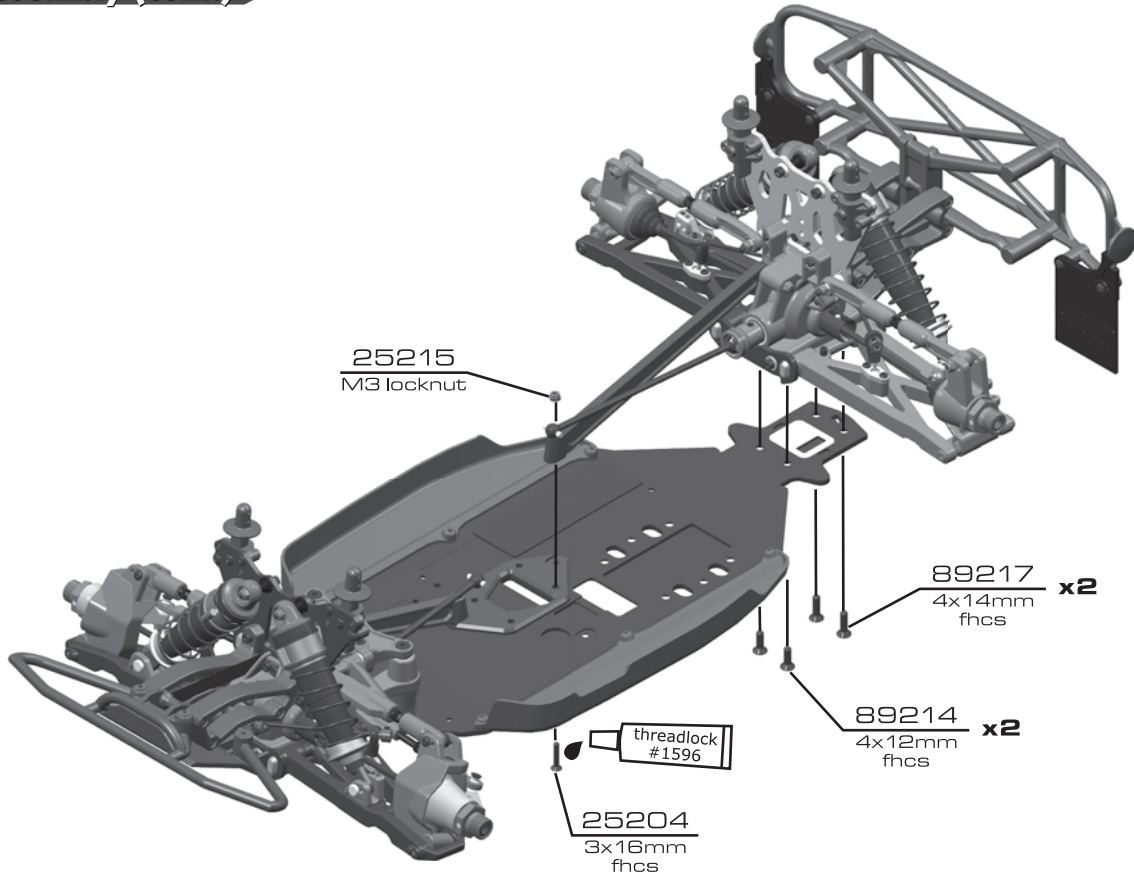

:: Center Bulkhead

BAG J

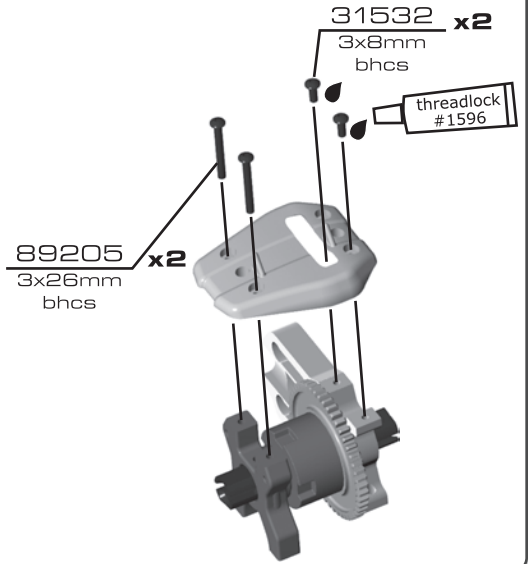
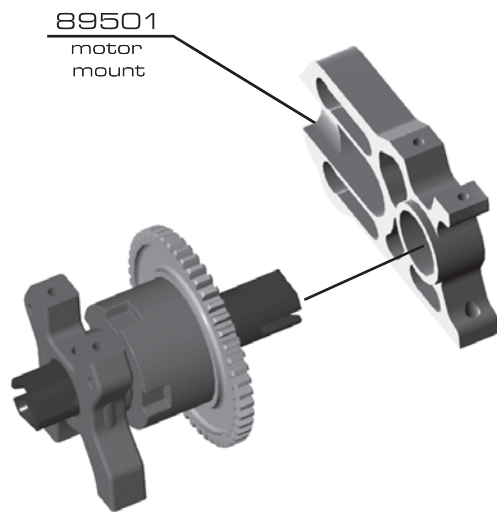
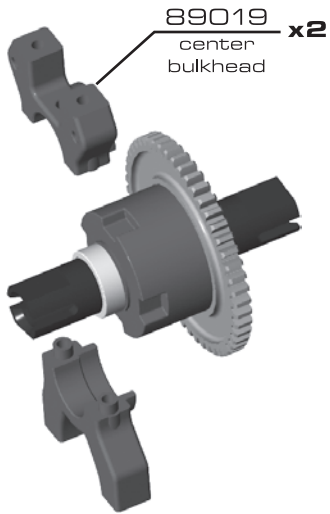

:: Center Bulkhead (cont.)



*Ensure dogbones are installed into diff outdrive cups.

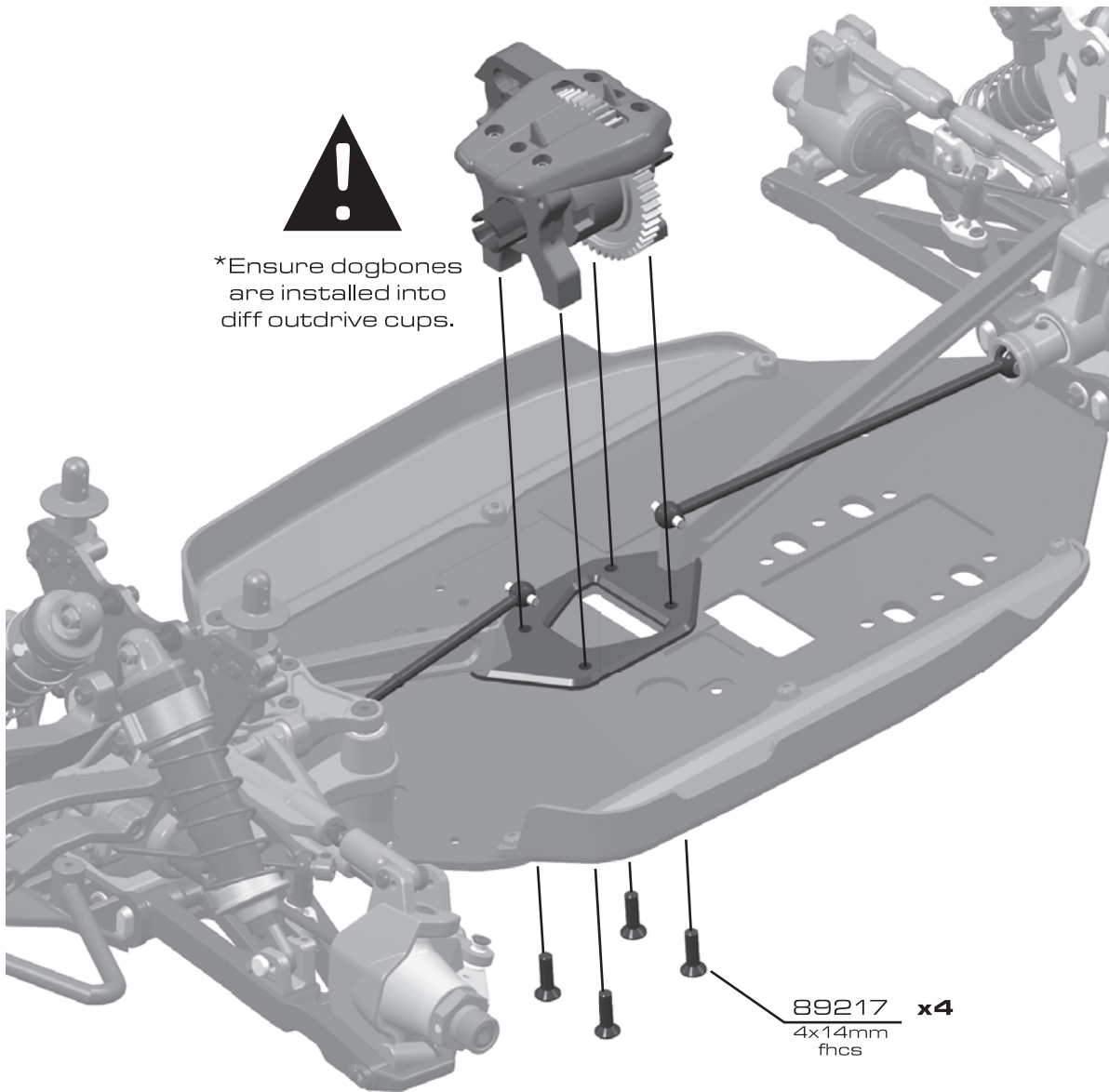

:: Battery / Radio Tray Build

BAG K

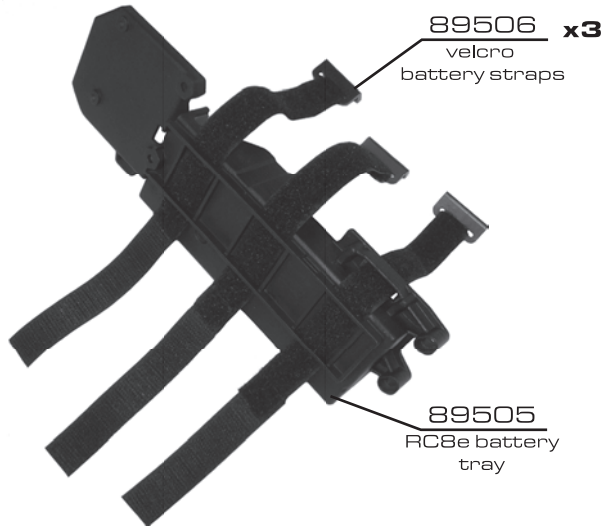

note:
speed control
not included.
attach with
servo tape.

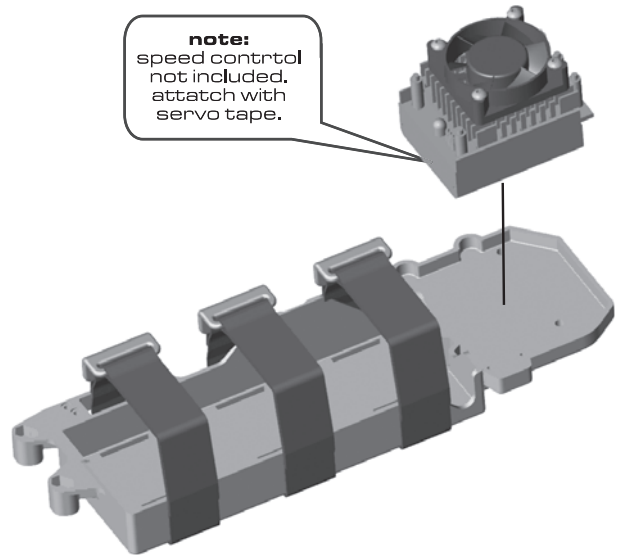

:: Battery / Radio Tray Build (cont.)

note:
route the speed
control receiver
wire through
this opening

note:
route the speed
control receiver
wire through
this opening

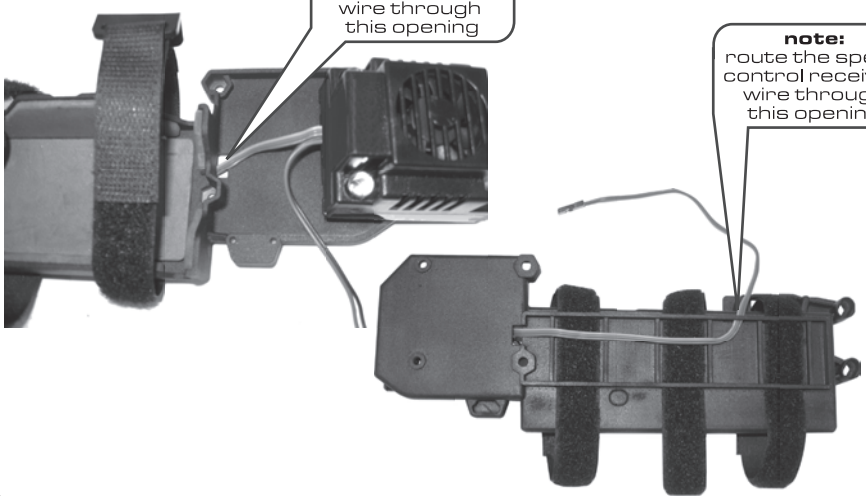

89509
flywheel
opening cover

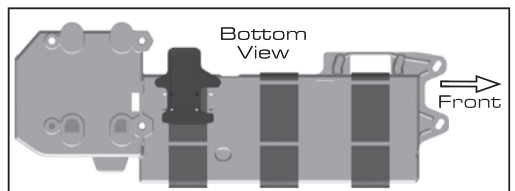
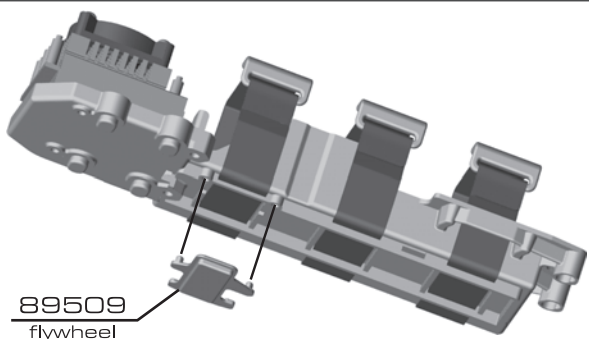

:: Battery / Radio Tray Build (cont.)

89509
battery tray
bridge

89222 x4
2.5x8mm
shcs

note:
the cutout on
the battery tray
bridge is facing
the battery tray!

note:
there are two
different positions
for the bridge screws
depending on what
vehicle you have.

89504
radio tray
(bottom)

note:
end velcro
strap removed
for picture
clarity only!

RC8e
SC8e

RC8e
SC8e

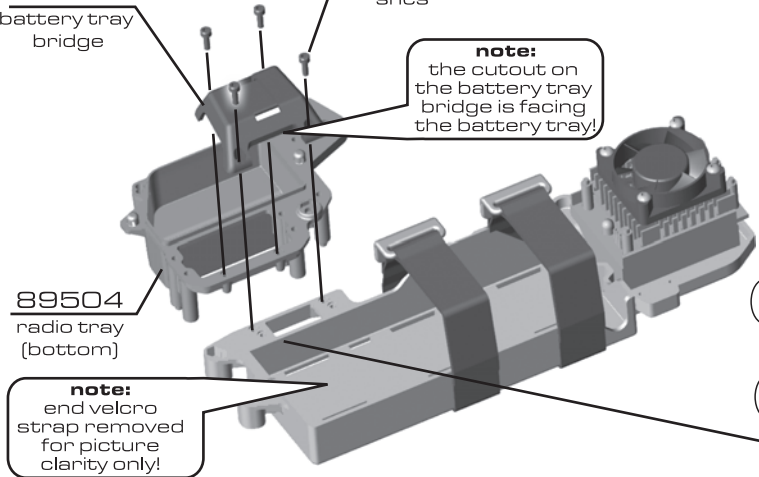
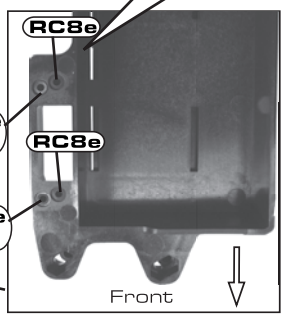

:: Battery / Radio Tray Build (cont.)



note:
route the speed control receiver wire up and over the bridge

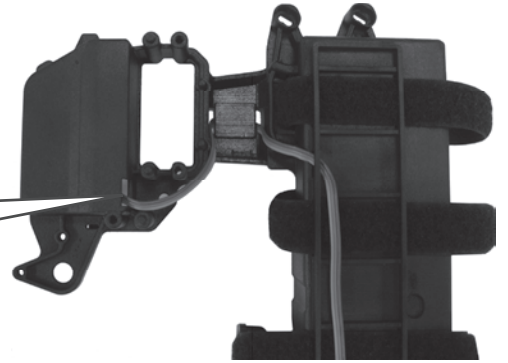

note:
route the speed control receiver wire through the radio box hole

:: Battery / Radio Tray Build (cont.)

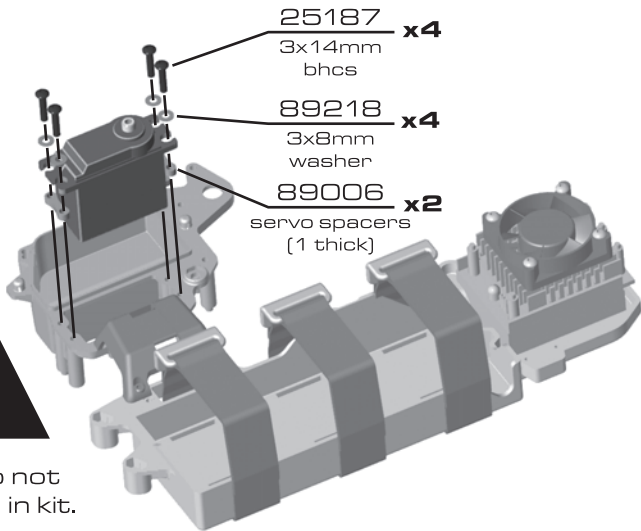

25187
3x14mm bhcs x4

89218
3x8mm washer x4

89006
servo spacers (1 thick) x2



*Servo not included in kit.



note:
route the servo wire to the receiver through this opening

optional transponder mount location

:: Battery / Radio Tray Build (cont.)

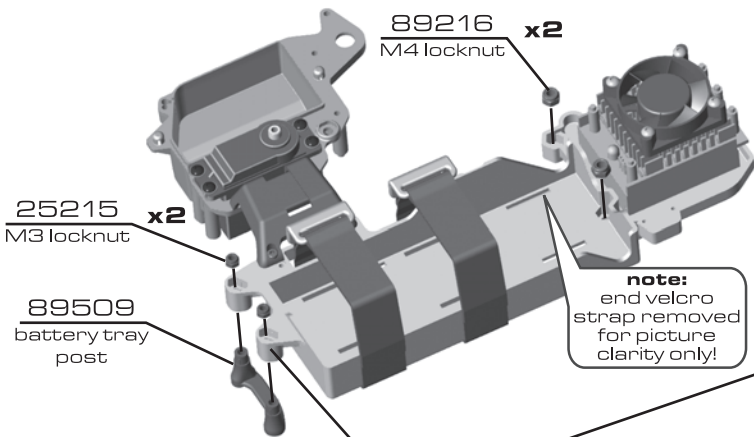

89216
M4 locknut x2

25215
M3 locknut x2

89509
battery tray post

note:
end velcro strap removed for picture clarity only!

note:
there are two different positions for the locknuts depending on what vehicle you have.

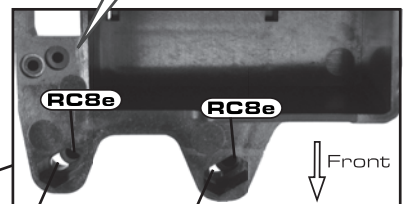

RC8Te
SC8e

RC8Te
SC8e

Front

:: Battery / Radio Tray Install



*screws and transponder not included in kit

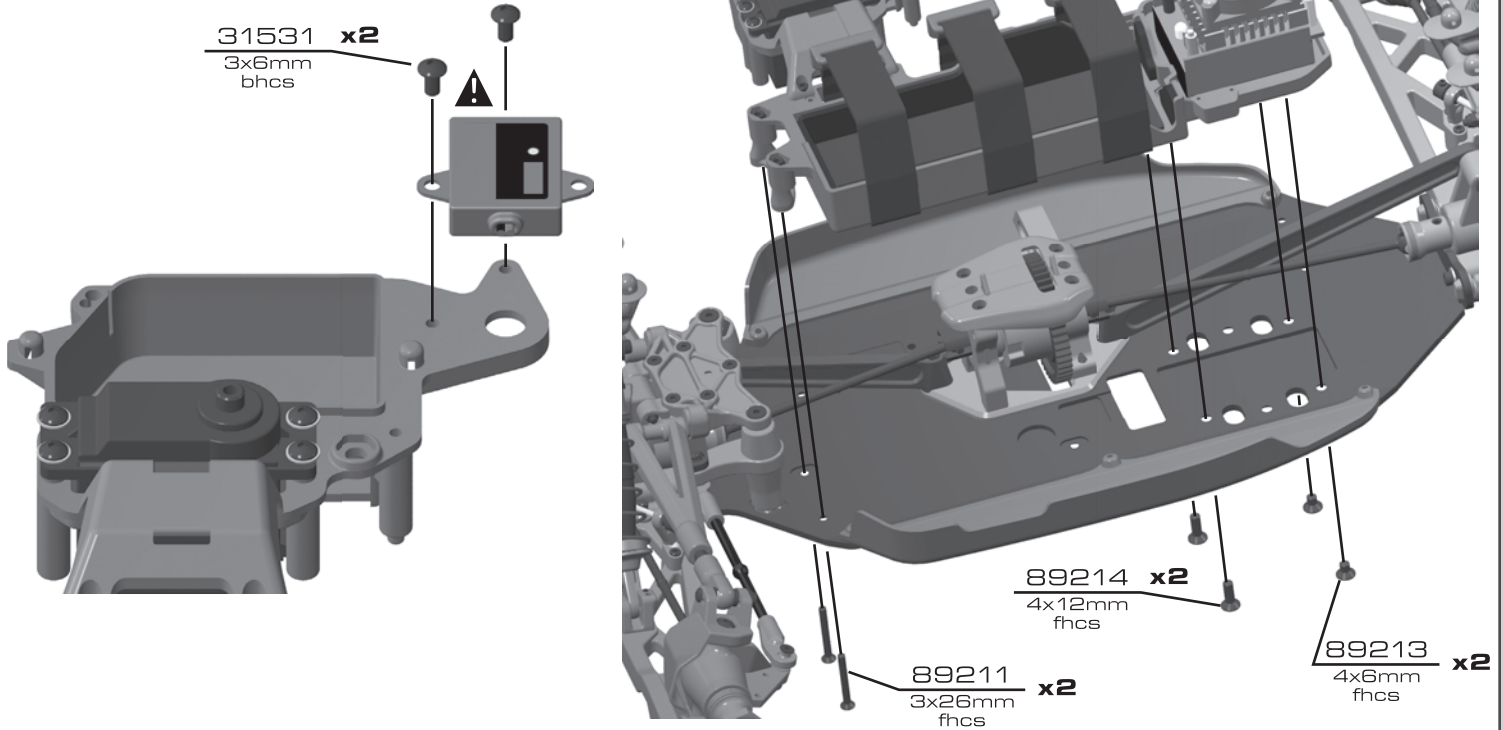

:: Battery / Radio Tray Install (cont.)

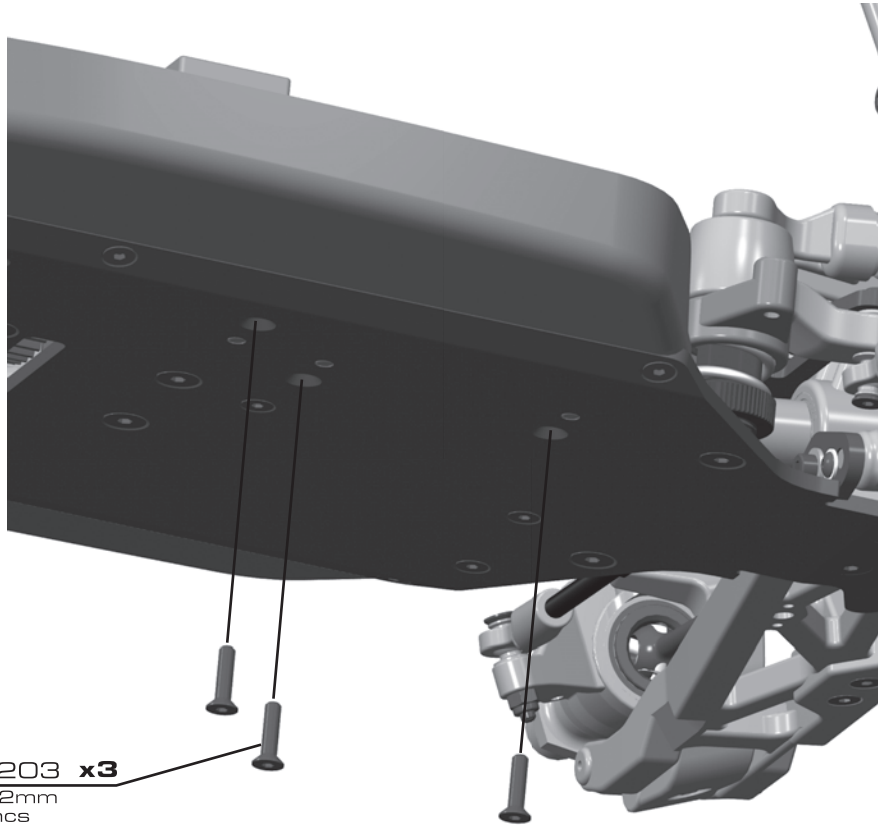

:: Battery / Radio Tray Install (cont.)

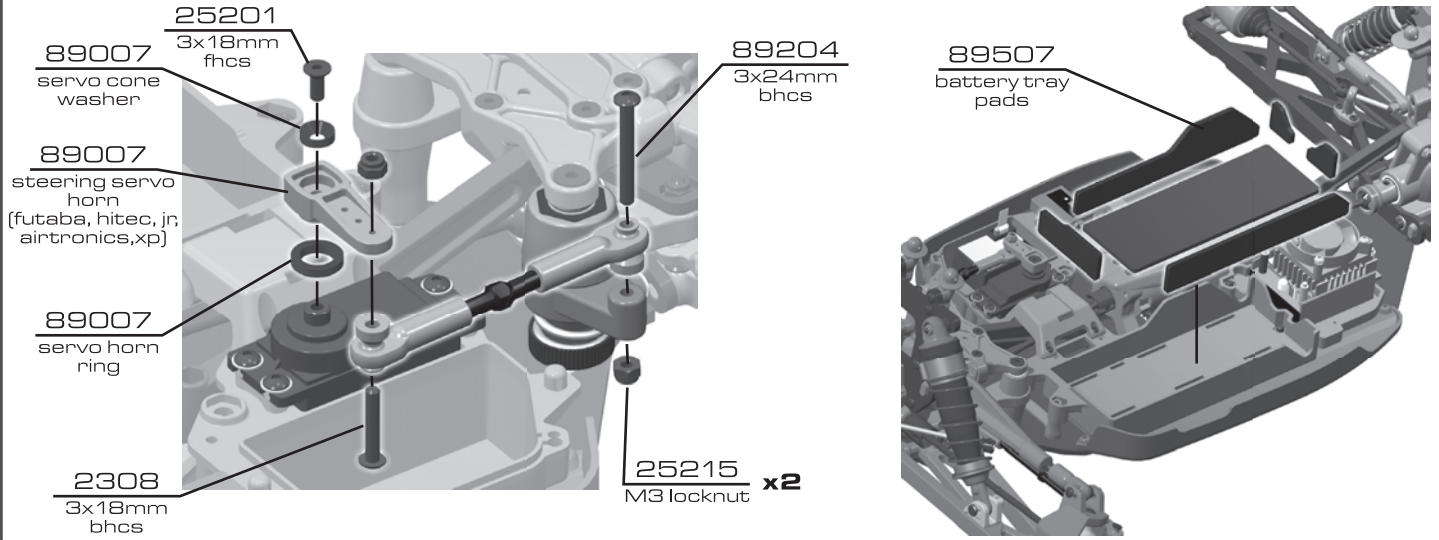

:: Battery / Radio Tray Install (cont.)

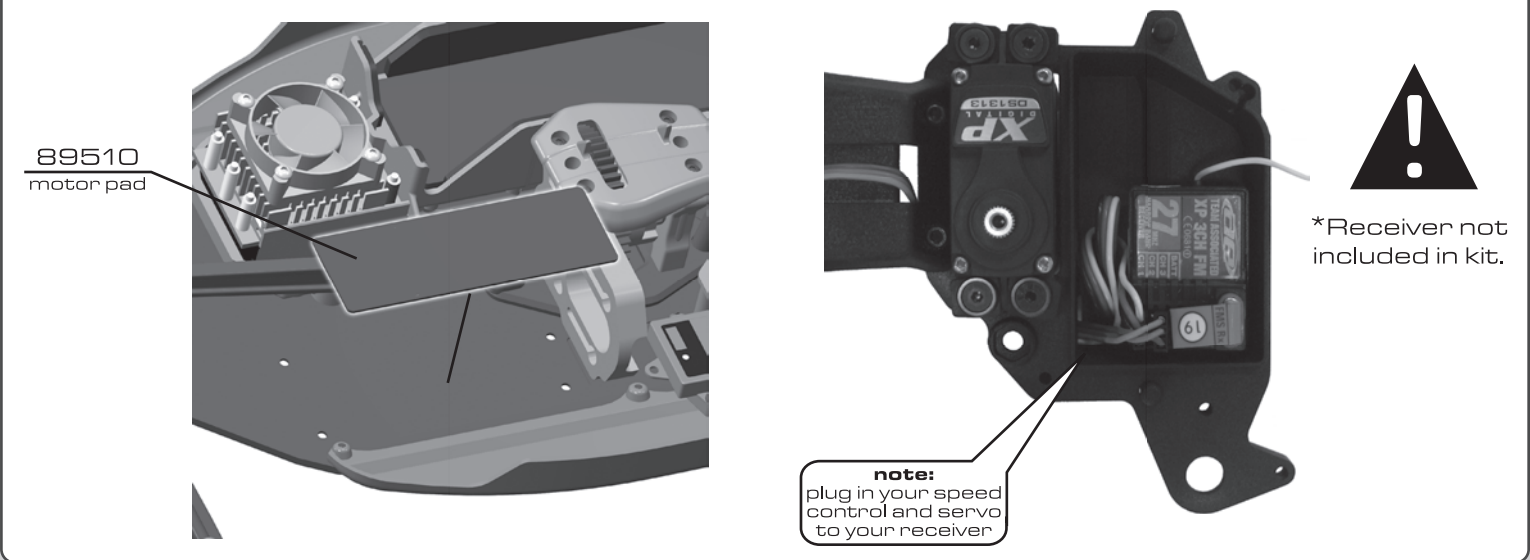

:: Battery / Radio Tray Install (cont.)

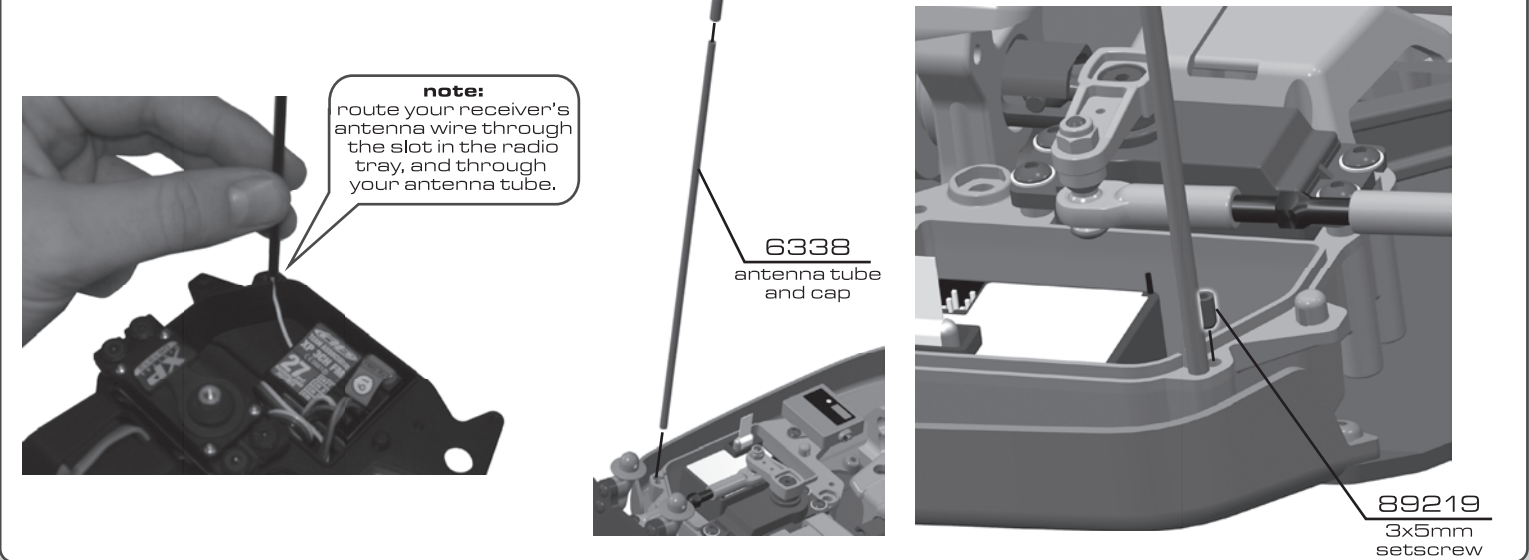

:: Battery / Radio Tray Install (cont.)

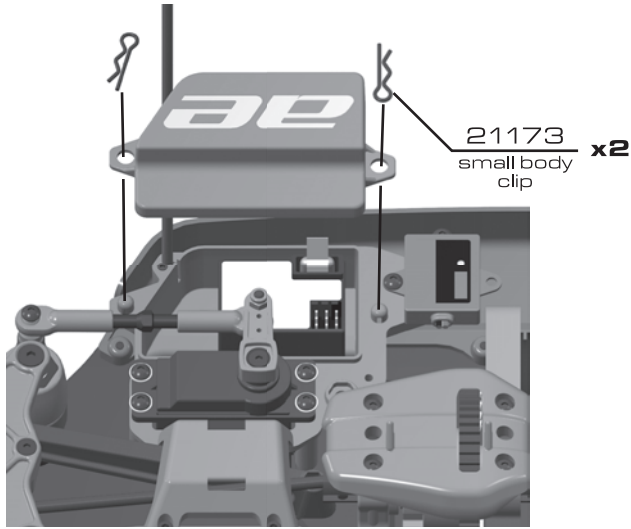

:: Electronics

BAGL

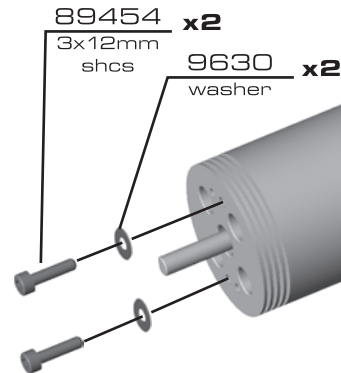

*Motor not included in kit.

:: Electronics (cont.)

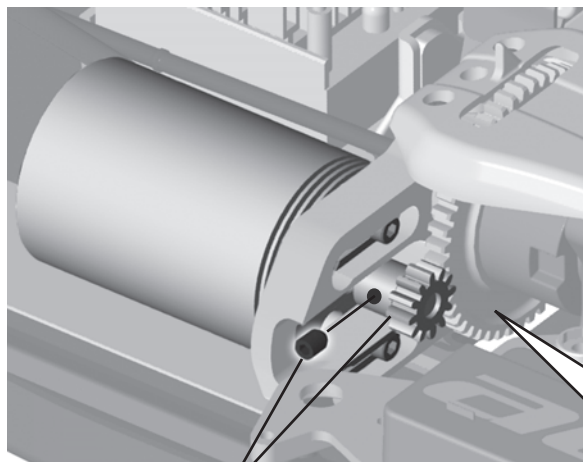
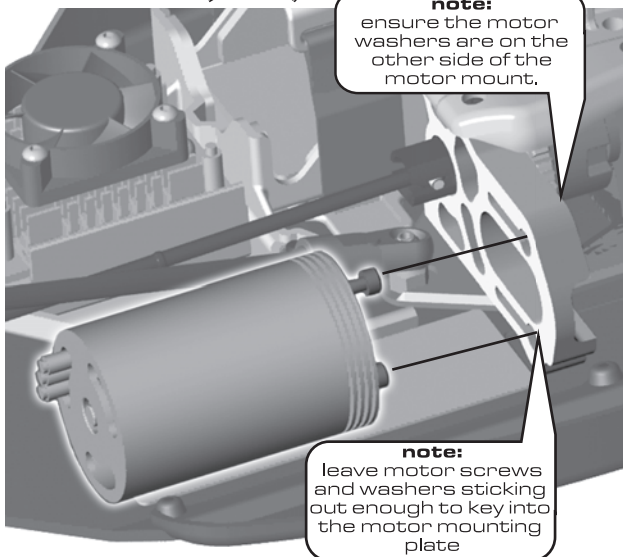

89515
15T pinion and set screw

note:
set gear mesh and tighten motor to the bulkhead with the included L wrench.

:: Electronics (cont.)

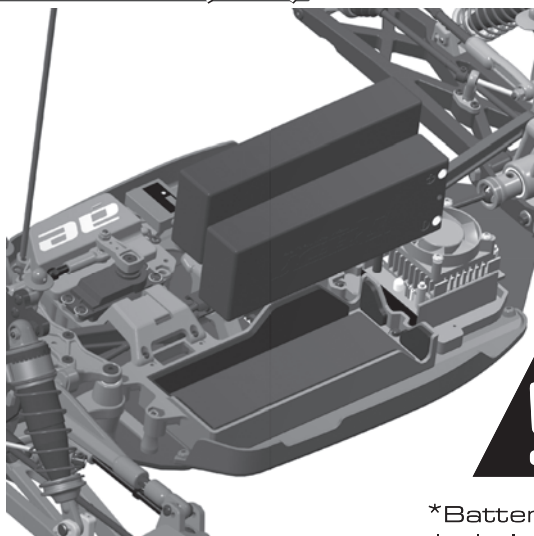

*Batteries not included in kit.

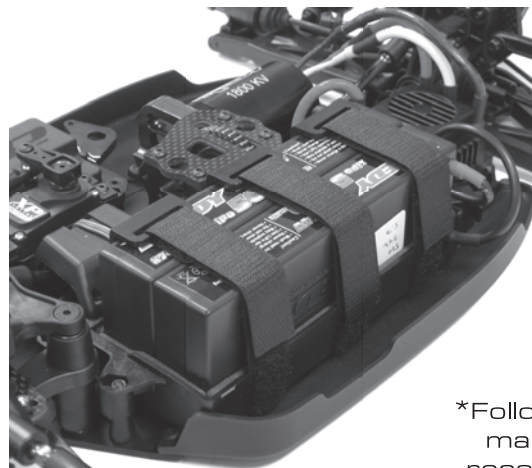

*Follow your battery manufacturer's recommendations for wiring setups.

:: Roll Cage Assembly

BAG M

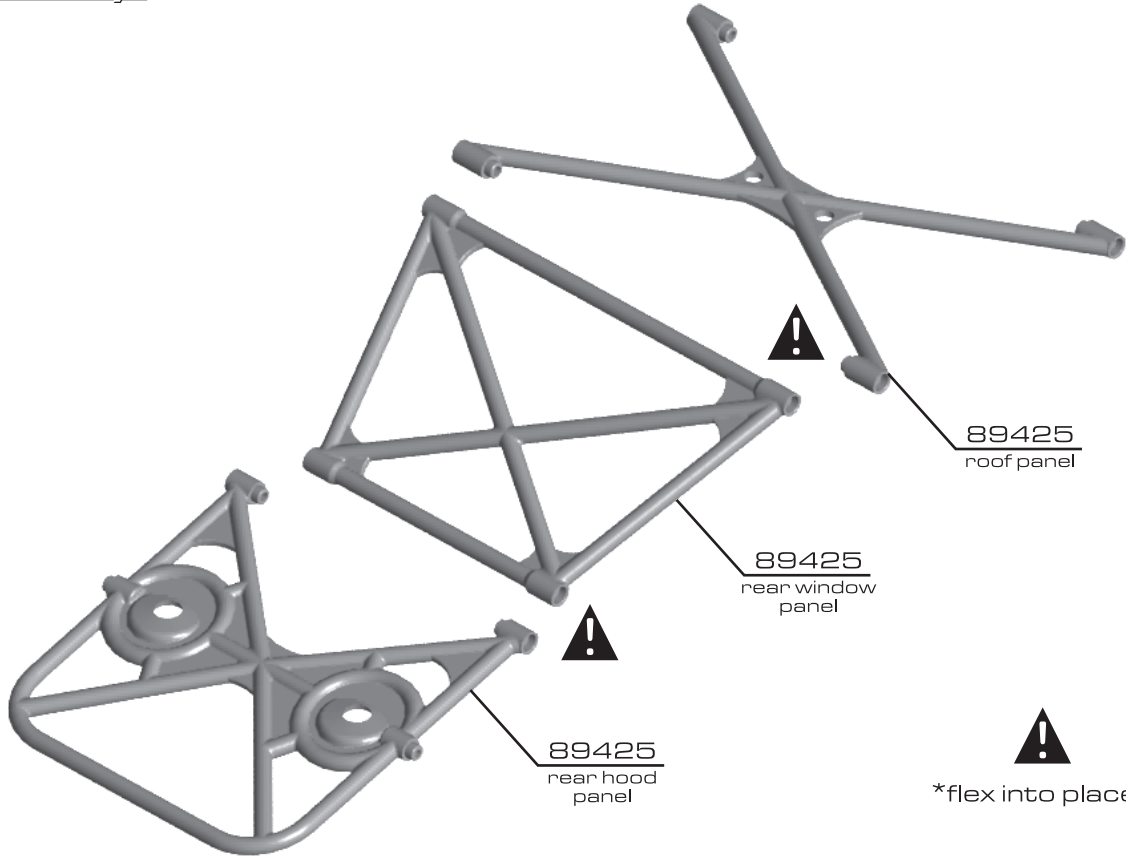

:: Roll Cage Assembly (cont.)

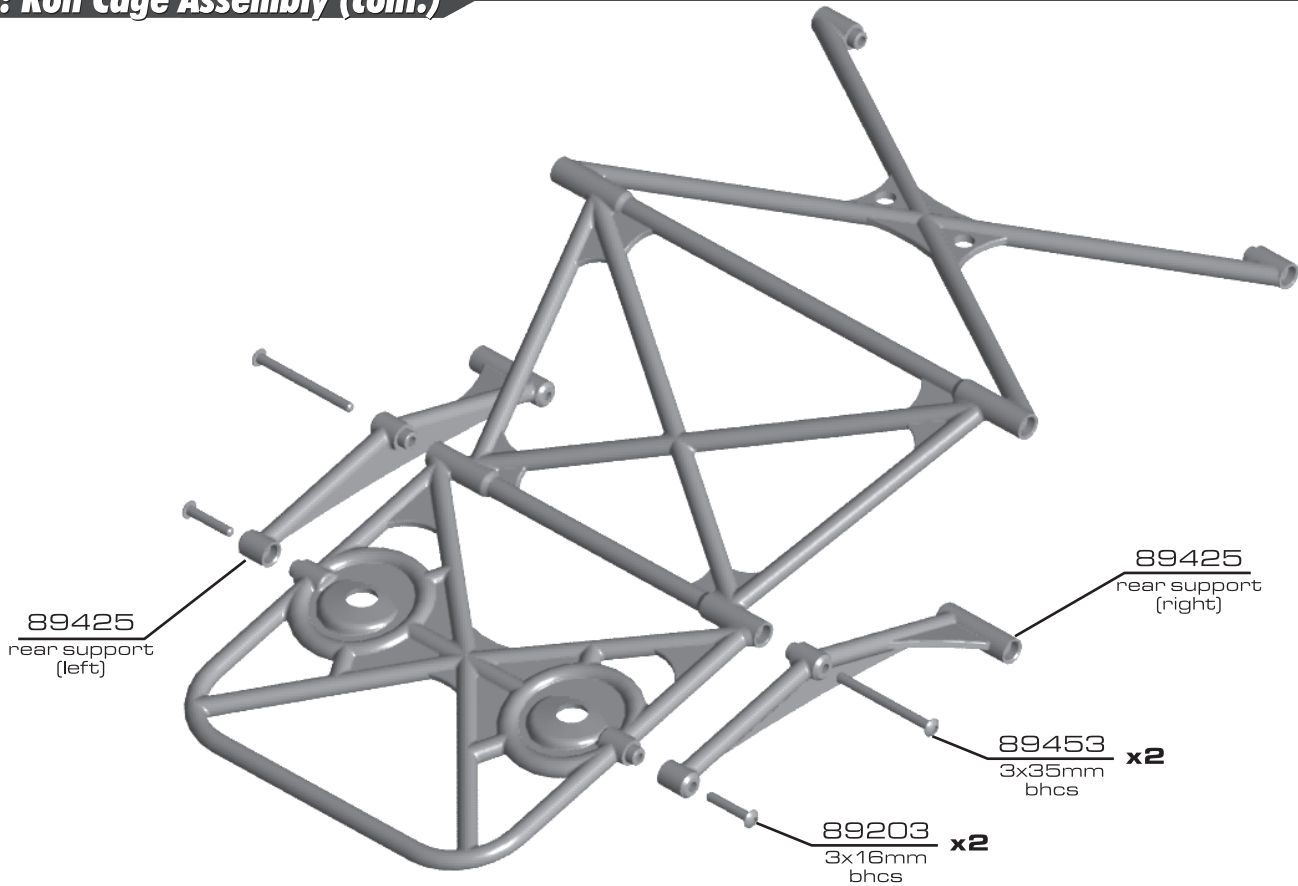

:: Roll Cage Assembly (cont.)

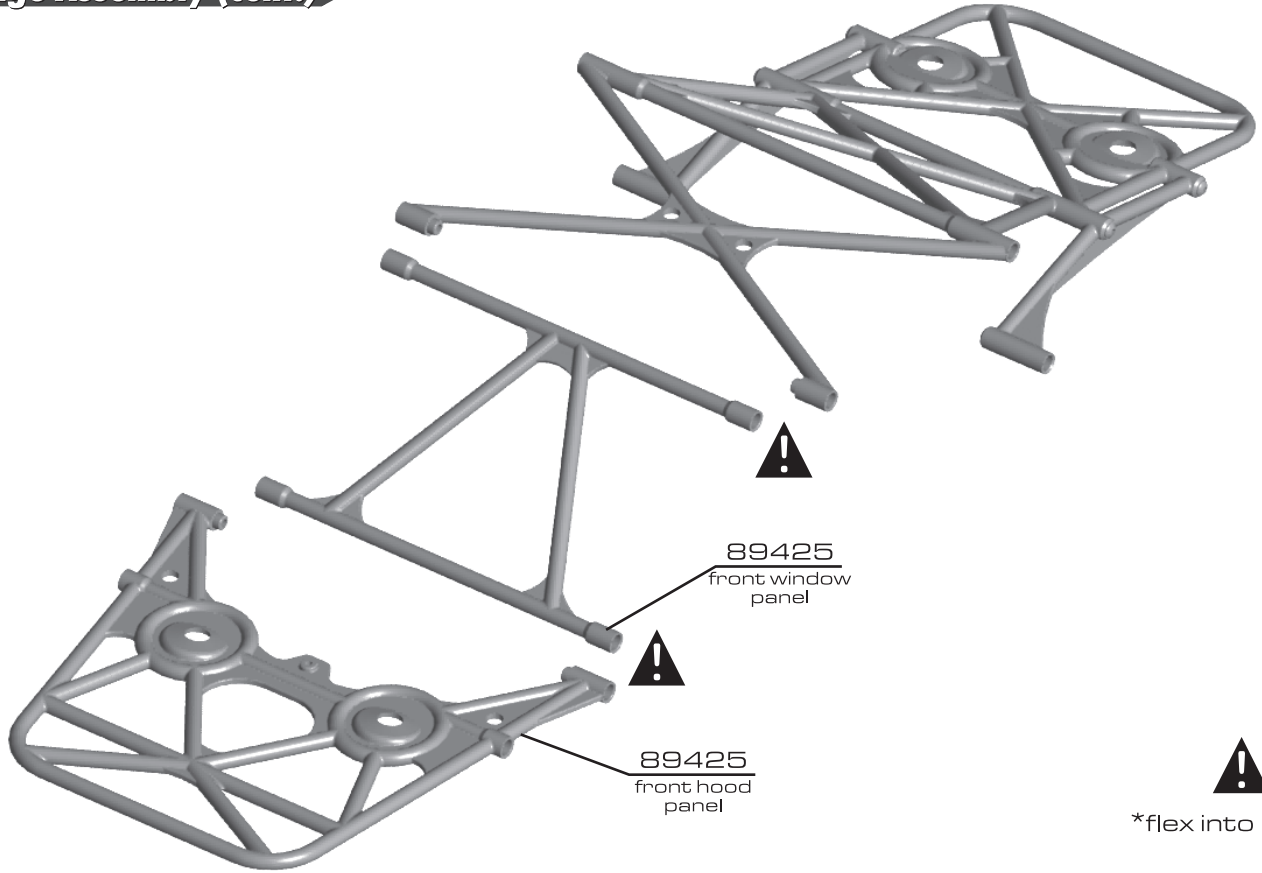

:: Roll Cage Assembly (cont.)

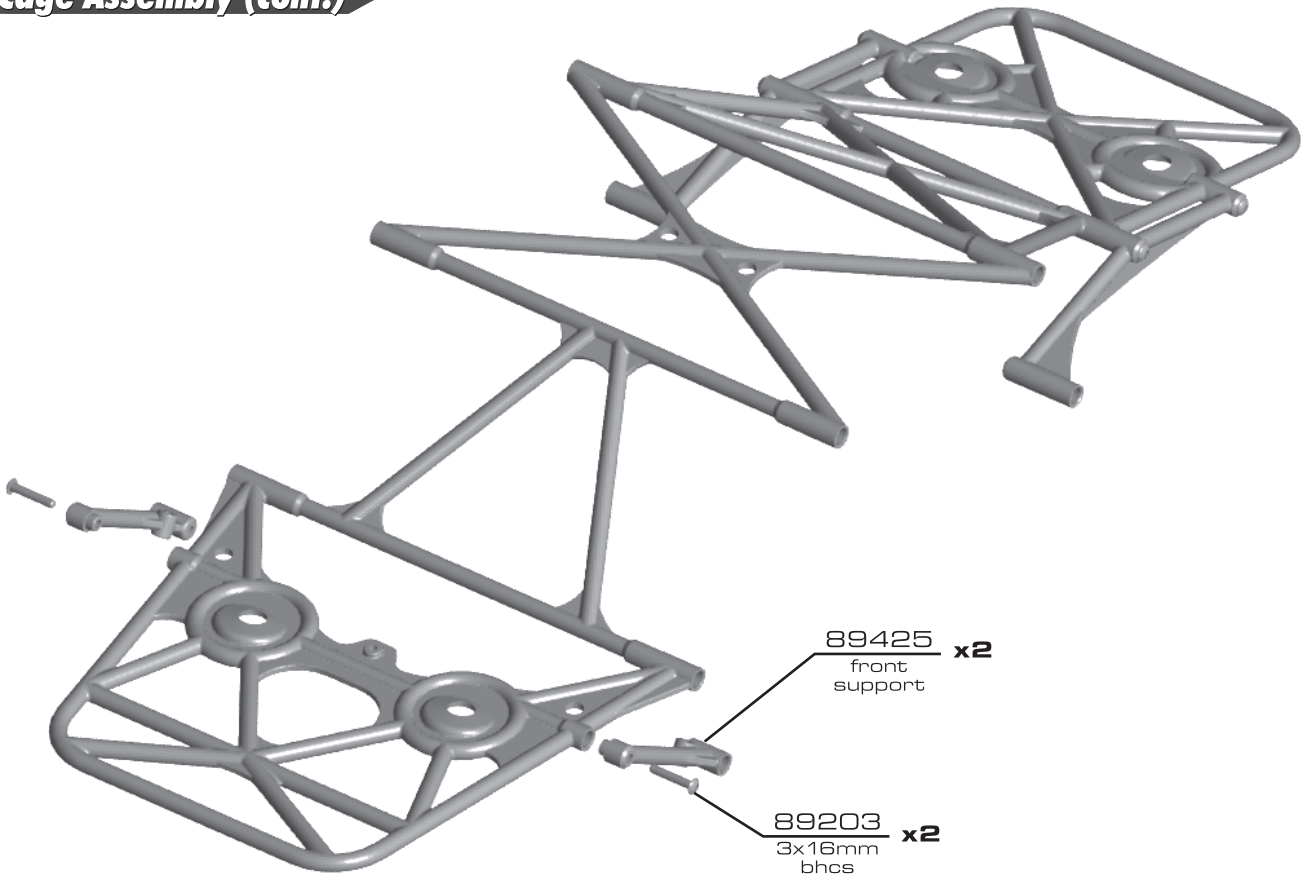

:: Roll Cage Assembly (cont.)

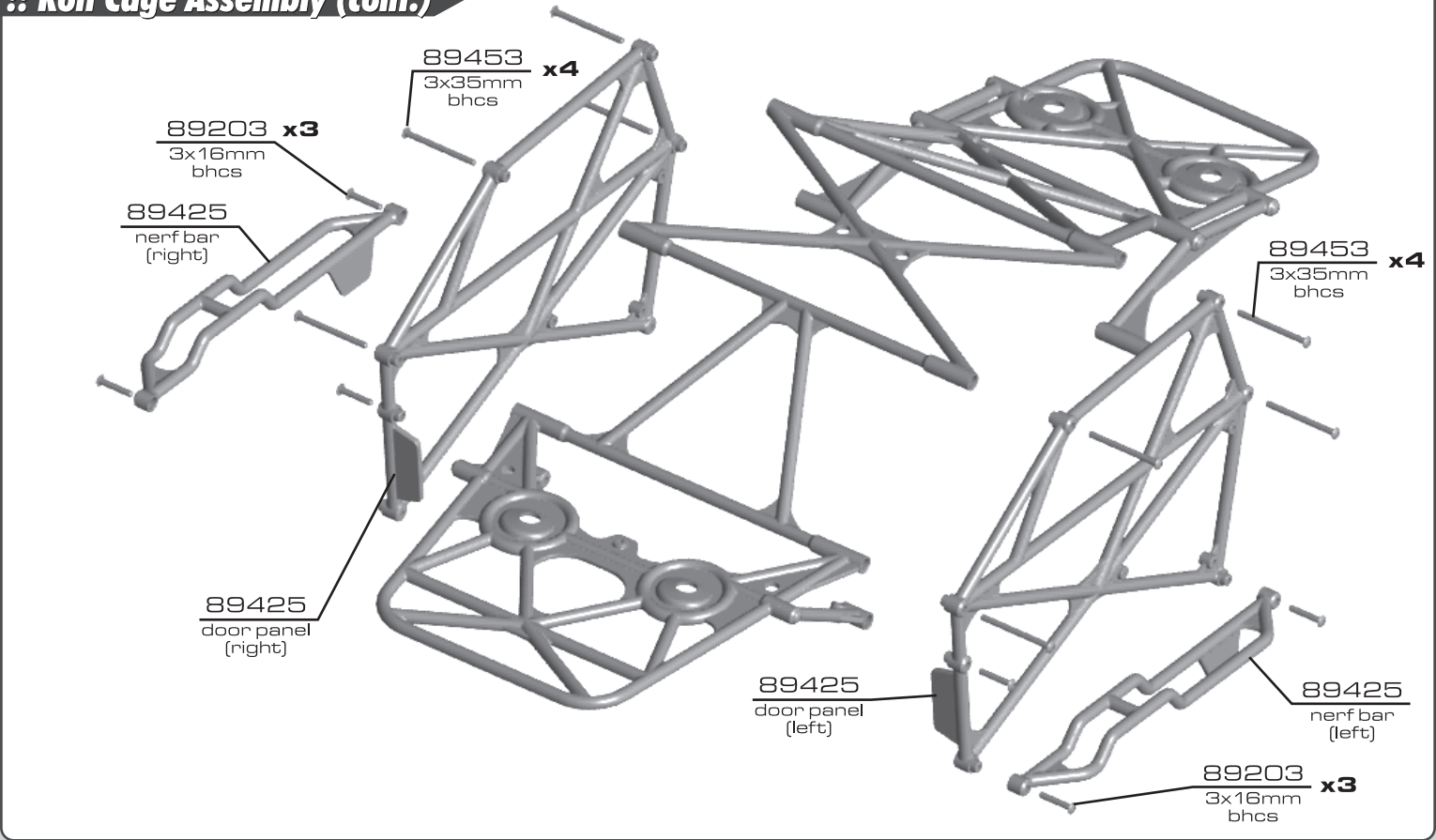

:: Roll Cage Assembly (cont.)

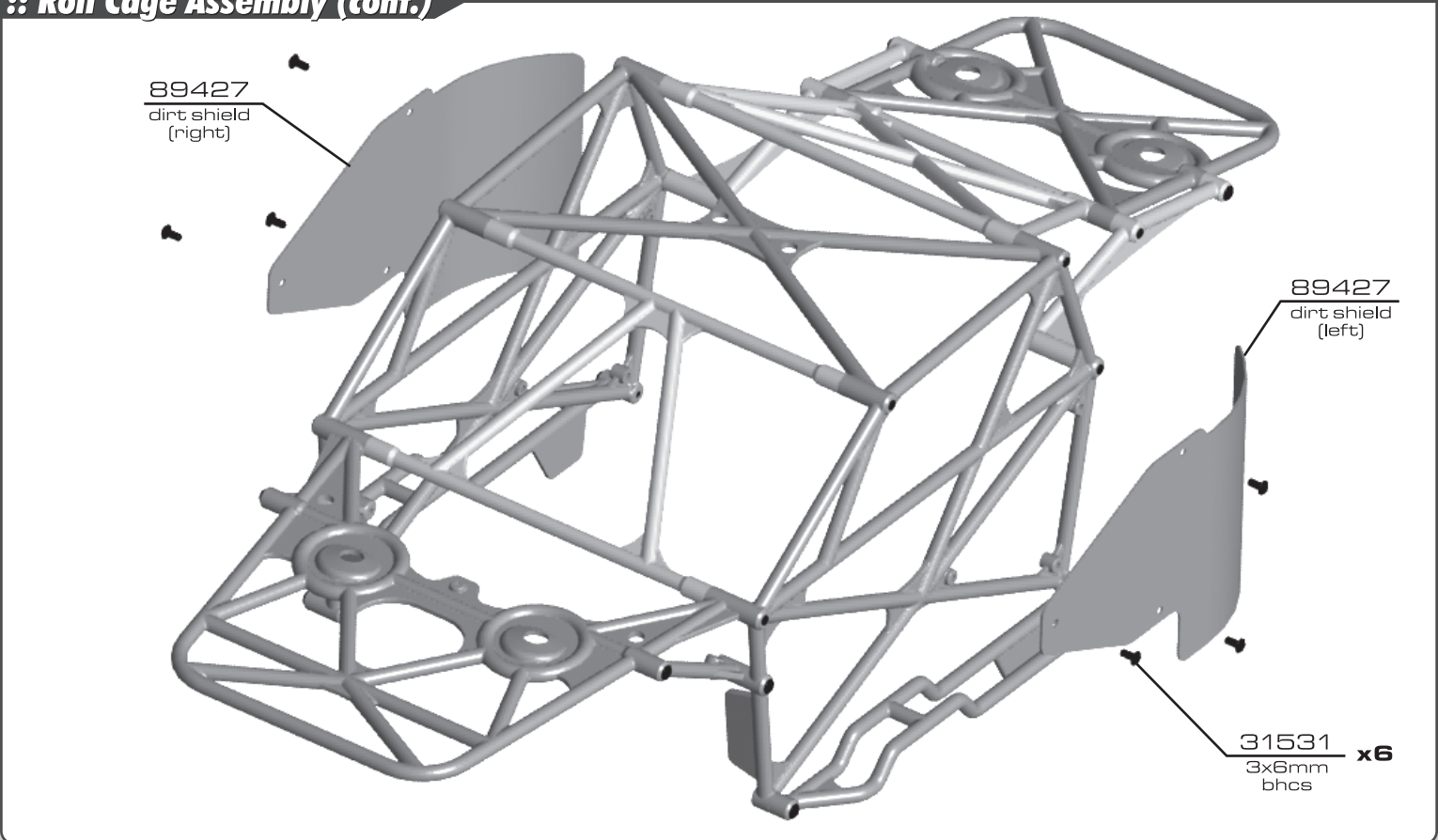

:: Roll Cage Assembly (cont.)

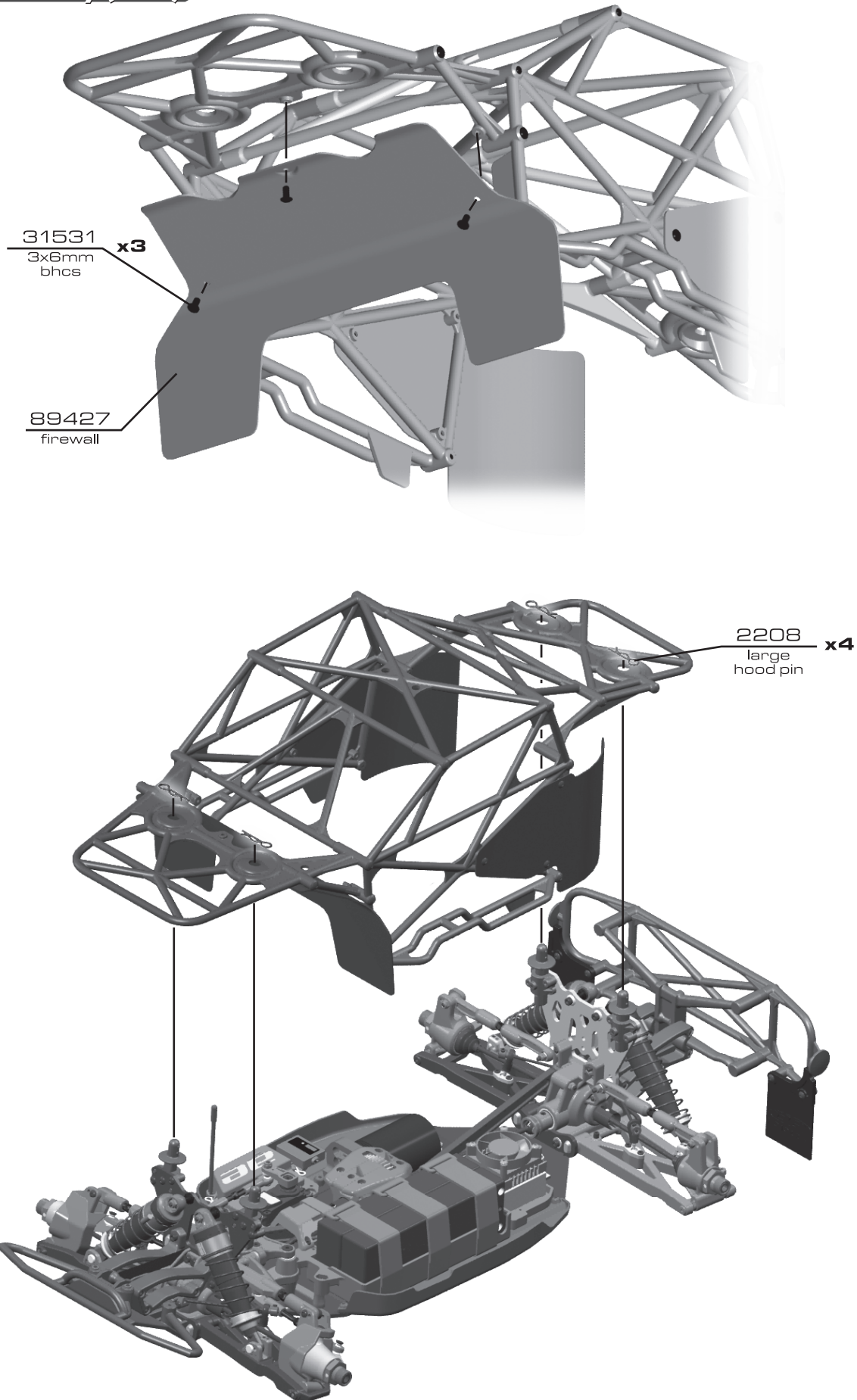

:: Wheel Assembly

89422
SC8 tire



89422
tire foam

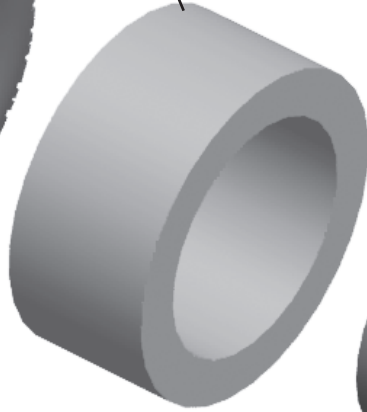

89401 (kmc silver)
89402 (kmc black)
89403 (12 spoke silver)
89404 (12 spoke black)
wheel

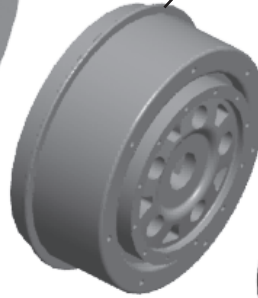

89416 (black)
89417 (silver) **x12**
2x4mm
bhcs

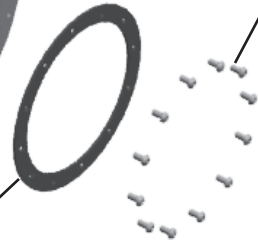

89407 (silver)
89408 (black)
89409 (red)
89410 (blue)
89411 (green)
89412 (gold)
beadguard



*Use tire adhesive (CA) to mount tires.

:: Wheel Assembly (cont.)

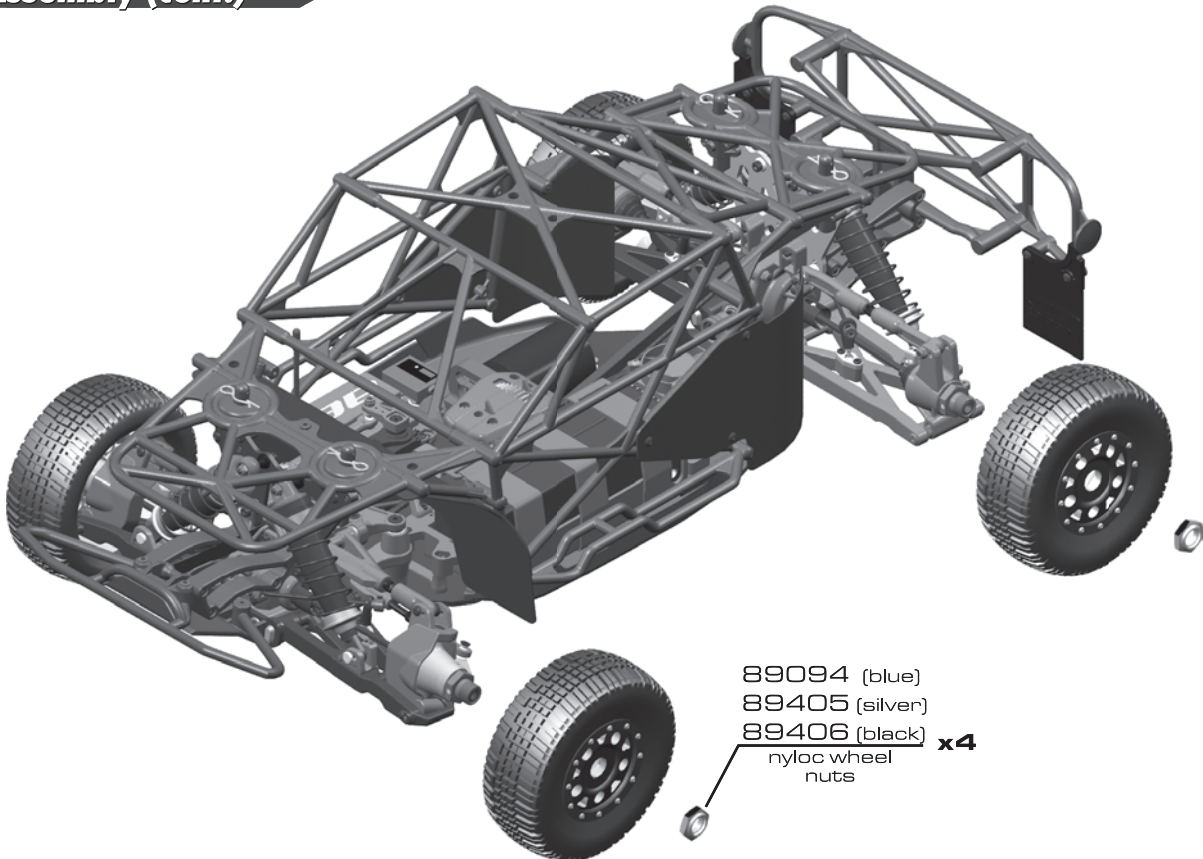

89094 (blue)
89405 (silver)
89406 (black) **x4**
nyloc wheel
nuts

:: Body Install

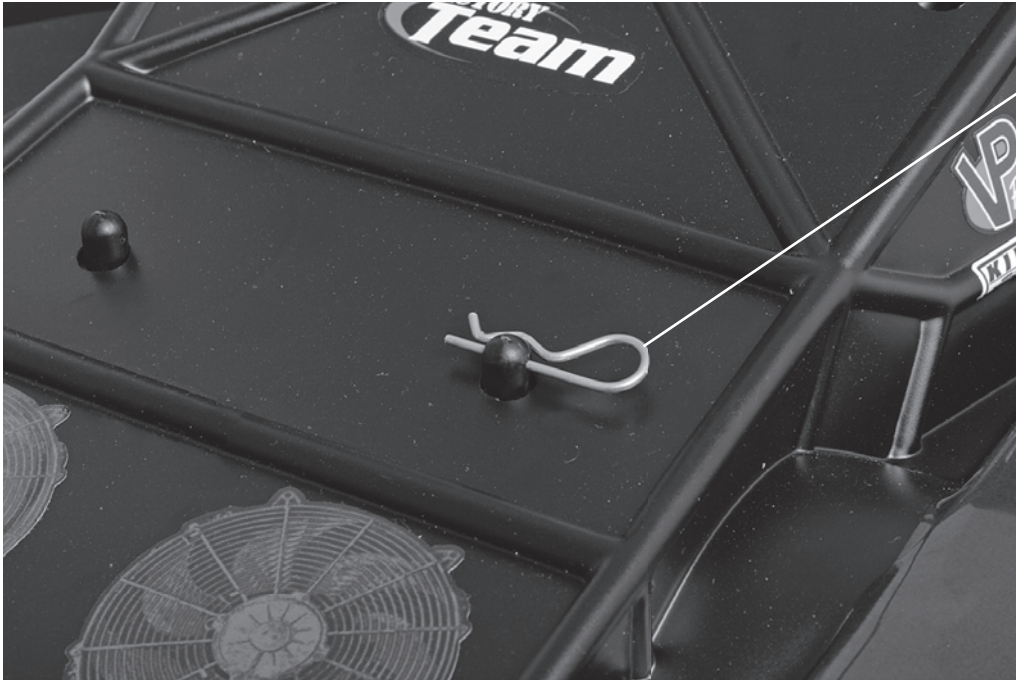

2208 x4
large
hood pin

:: Complete Truck



:: Driver: Team Associated :: Date: _____
 :: Track: Standard SC8e Setup
 :: Event: _____

Setup Sheet for Team Associated's SC8e

Rev. 1

:: Front Suspension

anti-roll bar: 2.2 - black
 2.5 - silver
 2.8 - gold

front body mount hole: 

hinge pin bushing: # 1
 up down

camber: -2 °

caster: 16 °

toe: 0 °

ride height: 29mm

kickup bushing: # 2
 up down

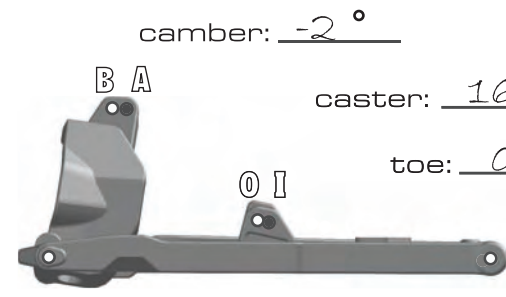

:: Rear Suspension

anti-roll bar: 2.2 - black
 2.5 - silver
 2.8 - gold

wheelbase: long
 medium
 short

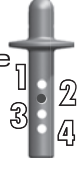
rear body mount hole: 

camber: -2 °

toe: 3 °

ride height: 29mm

anti-squat bushing: # 2
 up down

hub: upper
 lower

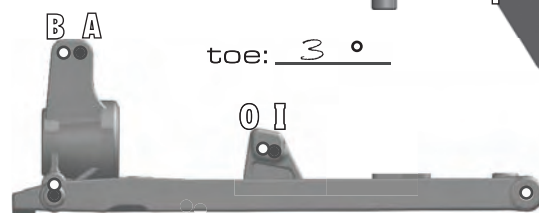

:: Front Shocks

spring: (4.7 lb) Bronze piston: 1.3
 shock fluid: 25 wt length: 113mm
 shock cap: molded

:: Rear Shocks

spring: (3.3 lb) Silver piston: 1.3
 shock fluid: 25 wt length: 125mm
 shock cap: molded

:: Differentials

front fluid: 10,000cst center fluid: 10,000cst
 rear fluid: 10,000cst

:: Chassis Braces

pivot molded aluminum
 other: _____

:: Electronics

motor & wind: _____
 esc: _____ setting: _____
 batteries: _____
 radio: _____
 steering expo: _____
 brake e.p.a.: _____
 throttle expo: _____
 servo: _____
 initial brake: _____ drag brake: _____

:: Gearing

pinion gear: 15t
 spur gear: 46t

:: Tires

tire (F/R): _____ / _____
 compound (F/R): _____ / _____
 insert: _____ wheel: _____
 traction additive: _____

:: Race and Vehicle Comments

qualify: _____ main: _____ finish: _____ tq:
 comments: _____

:: Track Info

traction: high med. low
 surface: smooth bumpy
 blue groove soft dirt grass
 clay wet dusty
 other: _____

:: Hardware - 1:1

flat head (fhcs)

METRIC

	3x8mm (25201)
	3x12mm (25203)
	3x14mm (89208)
	3x16mm (89224)
	3x18mm (25191)
	3x20mm (89210)
	3x22mm (89455)
	3x26mm (89211)
	4x6mm (89213)
	4x12mm (89214)
	4x14mm (89217)

cap head (shcs)

METRIC

	2.5x8mm (89222)
	3x12mm (89454)
	3x14mm (25190)
	3x16mm (89224)
	3x18mm (25191)
	3x20mm (25192)
	3x24mm (89225)
	3x26mm (89226)
	3x40mm (89228)
	3x50mm (89452)

button head (bhcs)

METRIC

	2x4mm black (89416)
	silver (89417)
	2.5x3mm (89201)
	2.5x6mm (31520)
	3x6mm (31531)
	3x10mm (25211)
	3x12mm (89202)
	3x14mm (25187)
	3x16mm (89203)
	3x18mm (2308)
	3x20mm (25188)
	3x24mm (89204)
	3x26mm (89205)
	3x35mm (89453)

ball bearings

	steering bearing (89161)
	6x10mm (31404)
	8x16mm (25236)
	15x21mm (89162)

shims & washers

	aluminum balltud washer (9630)
	2.5mm washer (89278)
	blue countersunk washer (89229)
	silver cone washer (89230)
	3x8mm thin washer (89218)
	diff washer (89120)
	diff shim (89117)

setscrews

METRIC

	3x3mm (25225)
	3x5mm (89219)
	4x3mm (25223)
	4x12mm (89220)
	5x4mm (89221)

nuts (lock/plain)

	piston locknut (89215)
	m3 locknut (25215)
	flanged m3 locknut (25612)
	m4 locknut (89216)

notes

Setup Sheet for Team Associated's SC8e

Rev. 1

:: Front Suspension

- anti-roll bar:
- 2.2 - black
 - 2.5 - silver
 - 2.8 - gold

front body
mount hole



hinge pin
bushing

- up down

camber: _____



caster: _____

toe: _____

kickup bushing

- up down

ride height: _____

:: Rear Suspension

- anti-roll bar:
- 2.2 - black
 - 2.5 - silver
 - 2.8 - gold

- wheelbase:
- long
 - medium
 - short

rear body
mount hole



camber: _____

toe: _____

hub:
upper
lower

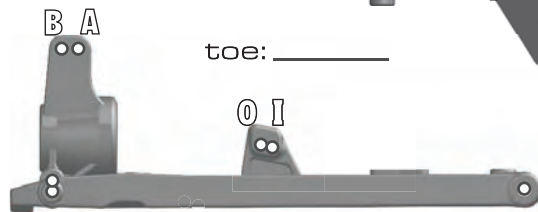

ride height: _____

anti-squat
bushing

- up down

:: Front Shocks

spring: _____ piston: _____
 shock fluid: _____ length: _____
 shock cap: _____

:: Rear Shocks

spring: _____ piston: _____
 shock fluid: _____ length: _____
 shock cap: _____

:: Differentials

front fluid: _____ center fluid: _____
 rear fluid: _____

:: Chassis Braces

- pivot molded aluminum

other: _____

:: Electronics

motor & wind: _____
 esc: _____ setting: _____
 batteries: _____
 radio: _____
 steering expo: _____
 brake e.p.a. : _____
 throttle expo: _____
 servo: _____
 initial brake: _____ drag brake: _____

:: Gearing

pinion gear: _____
 spur gear: _____

:: Tires

tire (F/R): _____ / _____
 compound (F/R): _____ / _____
 insert: _____ wheel: _____
 traction additive: _____

:: Race and Vehicle Comments

qualify: _____ main: _____ finish: _____ tq:

comments: _____

:: Track Info

- traction: high med. low
 surface: smooth bumpy
 blue groove soft dirt grass
 clay wet dusty

other: _____