



SC8e

SHORT COURSE



#80932 SC8e RTR Rockstar / Makita

BRUSHLESS

Ready-To-Run

1:8 Scale Electric 4WD Off Road Race Truck Manual & Catalog ^{7/10}

TEAM ASSOCIATED



Designed in California, USA

:: Introduction

Thank you for purchasing this Team Associated product. This manual contains instructions and tips for building and maintaining your new SC8e RTR. Please take a moment to read through it and familiarize yourself with these steps as they will help you to understand each component's function and show you some tips for getting the most out of your SC8e RTR. We are continually changing and improving our designs; therefore, actual parts may appear slightly different than the illustrations. New parts will be noted on supplementary sheets located in the appropriate parts bags. Check each bag for these sheets before you start to build.

:: SC8e RTR Features

- Rockstar / Makita replica SC8 body
- Mamba Max Pro ESC with Deans (TM) Ultra plug (works with 3S 11.1V or 4S 14.8V Lipo)
- Neu-Castle 2200 KV motor
- 16mm Big-Bore Molded Shocks with Pre-load Clips
- Functional full roll cage with integral dirt shields
- Upgraded Dual bell-crank steering with reduced bump-steer
- Authentic, scale 1.5mm thick short course truck body
- Black hard-anodized 7075 Alum. Chassis with keyed suspension plates
- 3 mm Aluminum shock towers
- Alloy Steel Turnbuckles
- Caster blocks adjust 14, 16, or 18 degrees with molded inserts
- 10 mm thick arms
- Molded suspension pivot bushings for adjustable pivot height
- 4.30:1 ratio gearboxes
- 3.5mm light CVA drivetrain
- Rear molded CVA boots to keep dirt and mud out of rear joints.
- Functional and realistic front and rear bumpers with mud flaps
- Scale wheels & tires with foam inserts and bead guards.
- Rigid one-piece motor mount utilizes standard motor screw mounting pattern
- Large speed control mounting area raised off of chassis to allow for easy screw mounting of common speed controllers
- Speed control mounting area includes convenient switch-mounting boss
- Utilizes 3 hook-and-loop straps to secure LiPo batteries into battery tray
- Molded Battery tray supports 7.4 -14.8V battery packs with room for foam pads
- Requires ROAR-approved 3S 11.1 V or 4S 14.8 V LiPo battery pack with Deans (R) Ultra Plug (R) (recommended #720 LiPo 14.8V, 5000 mAh, 40C).
- New sealed receiver box for proper electronics placement
- Receiver, Servo, and battery tray remove from car in one piece for easy maintenance and cleaning
- Convenient wire routing keeps critical electronic wires out of drivetrain components and simplifies disassembly
- Includes pinion gear (15T) and molded spur gear (46T)

:: Additional

:: Required Items

Your SC8e RTR Short Course Truck requires the following items to complete your kit:

- AA-Size Batteries for Transmitter (x8) (AE # 302, 303)
- 3S 11.1 V LiPo battery pack with Deans (TM) Ultra plug
- OR-
- 4S 14.8 V LiPo battery pack with Deans (TM) Ultra plug (AE # 720)
- Battery charger (peak detection charger recommended) (AE # LRP41281)

:: Other helpful Items

- Silicone Shock Fluid (Refer to catalog for complete listings)
- Silicone Diff Fluid (Refer to catalog for complete listings)
- Body Scissors (AE Part # 1737) • Reamer / Hole Punch
- FT Hex Wrench Set (AE Part # 1541) • Hobby Knife
- Needle Nose Pliers • Wire Cutters • Soldering Iron
- Calipers or a Precision Ruler



These symbols indicate a special note or instructions.

There is a 1:1 fold out in the back of the manual. Fold it out while building your kit for easy part sizing!



Associated Electrics, Inc.
26021 Commercentre Dr.
Lake Forest, CA 92630



Customer Service
Tel: 949.544.7500
Fax: 949.544.7501

<http://www.TeamAssociated.com> • <http://www.RC10.com> • http://twitter.com/Team_Associated • <http://bit.ly/AEonFacebook>

:: Front and Rear Differentials

BAG A

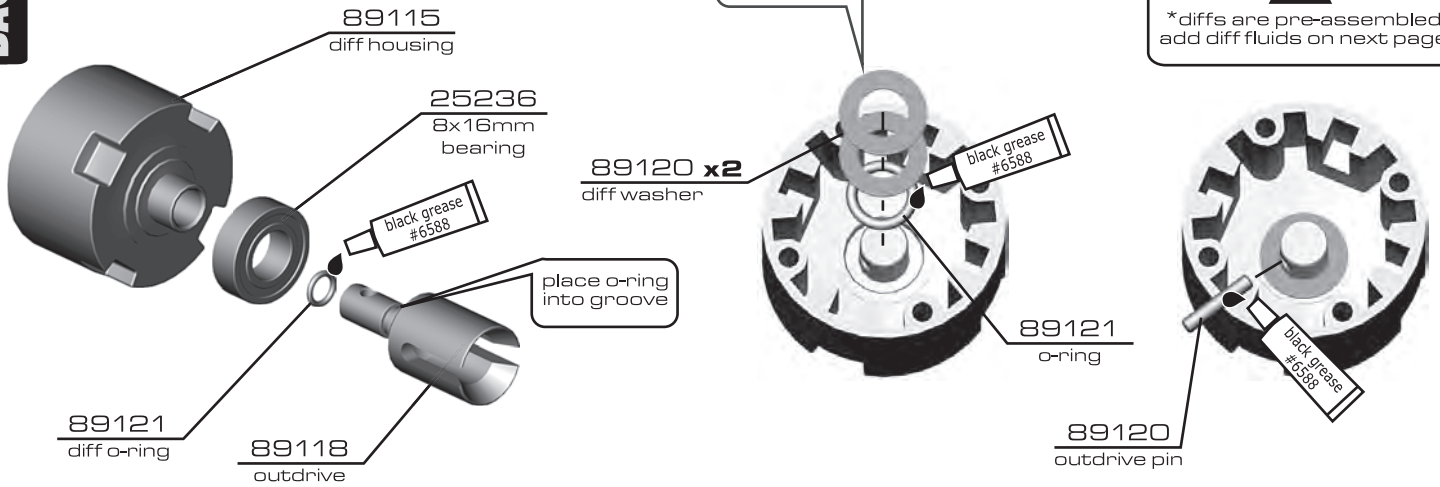

:: Front and Rear Differentials (cont.)

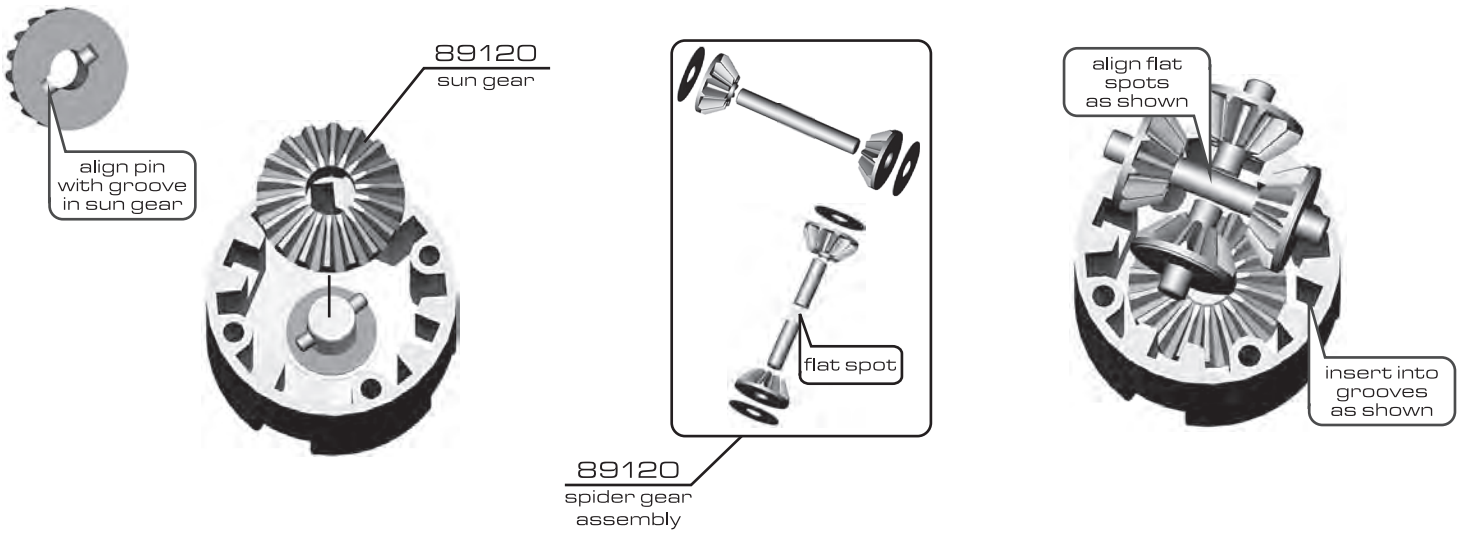

:: Front and Rear Differentials (cont.)

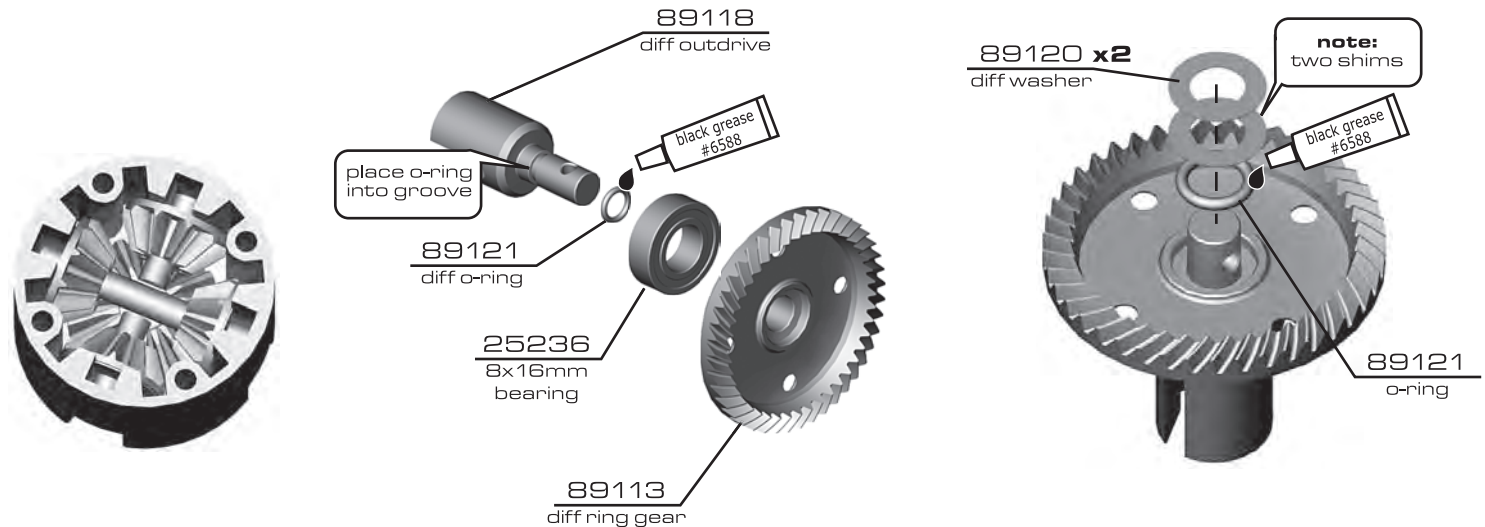

:: Front and Rear Differentials (cont.)

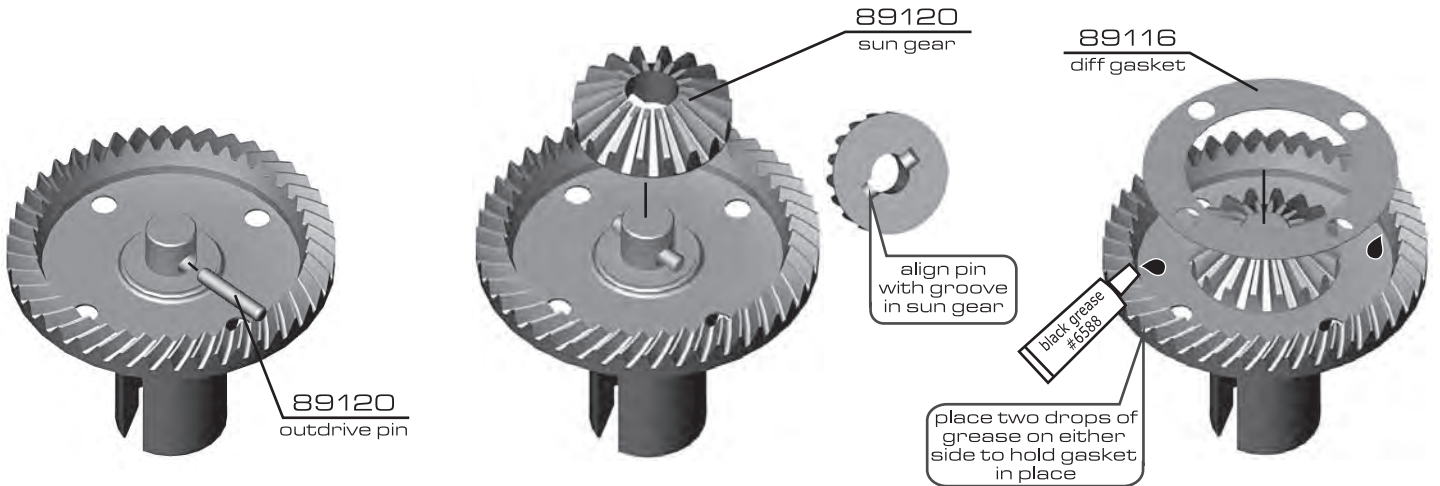

:: Front and Rear Differentials (cont.)

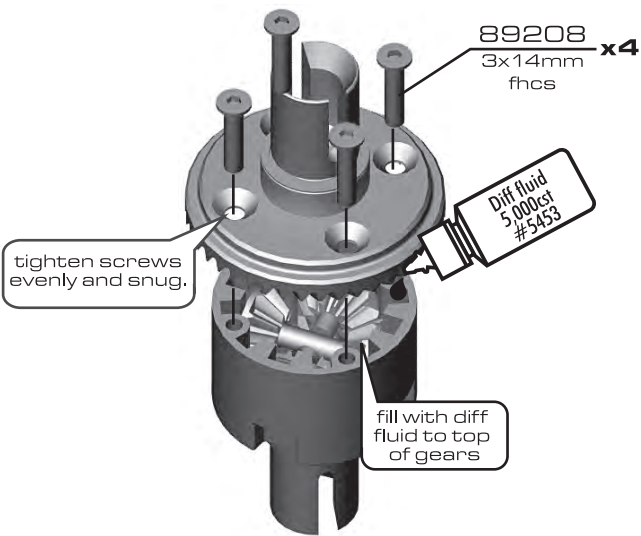

:: Center Differential

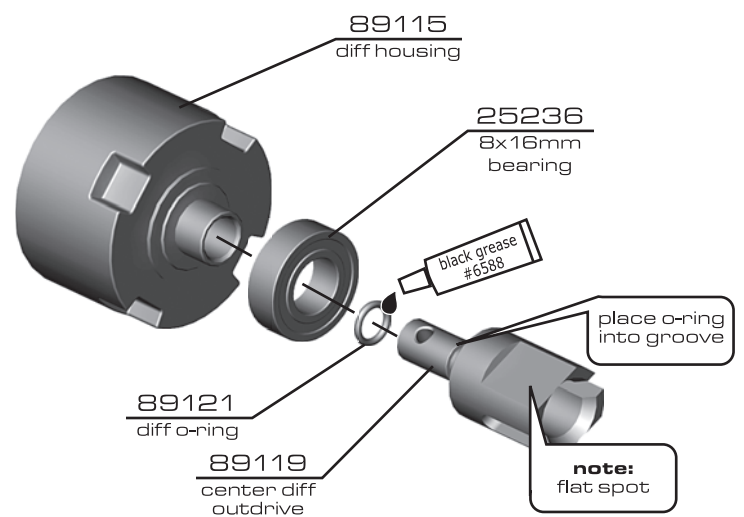

:: Center Differential (cont.)

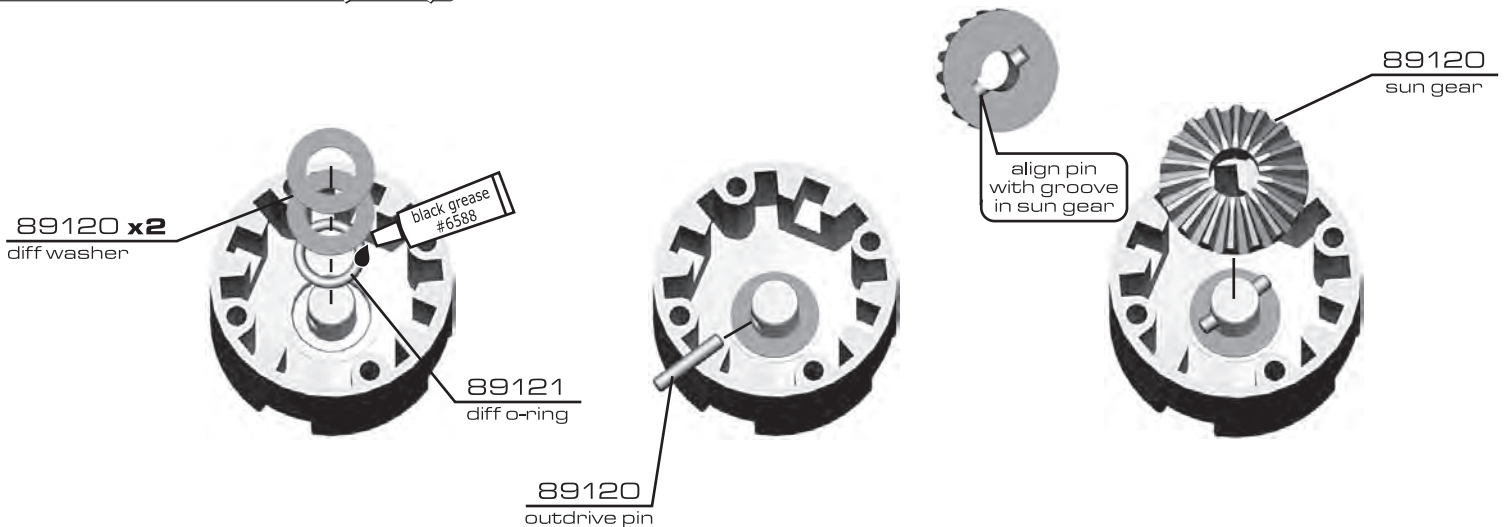

:: Center Differential (cont.)



89120 spider gear assembly

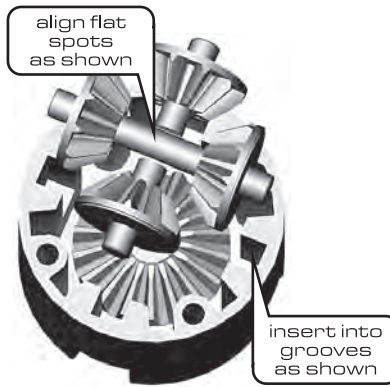

:: Center Differential (cont.)

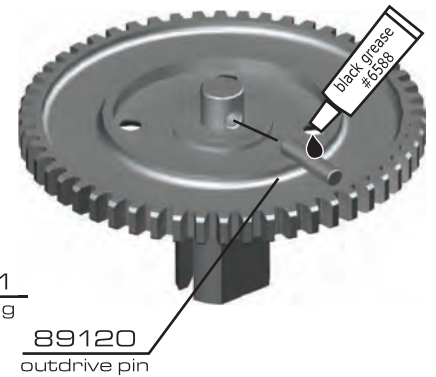
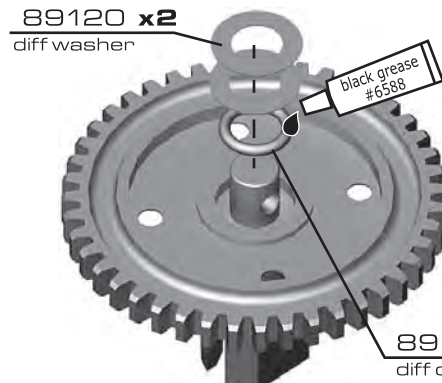
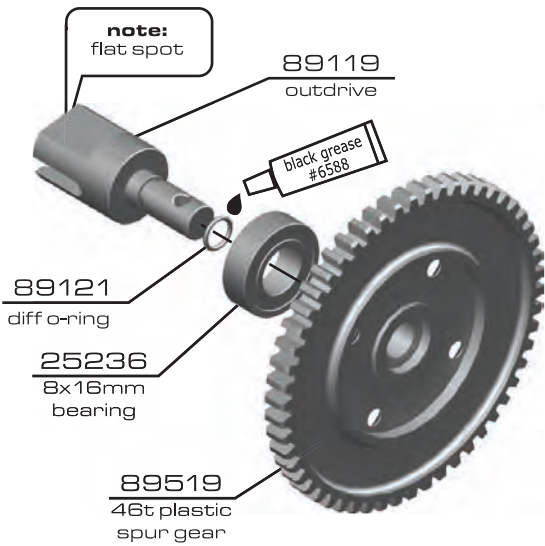

:: Center Differential (cont.)

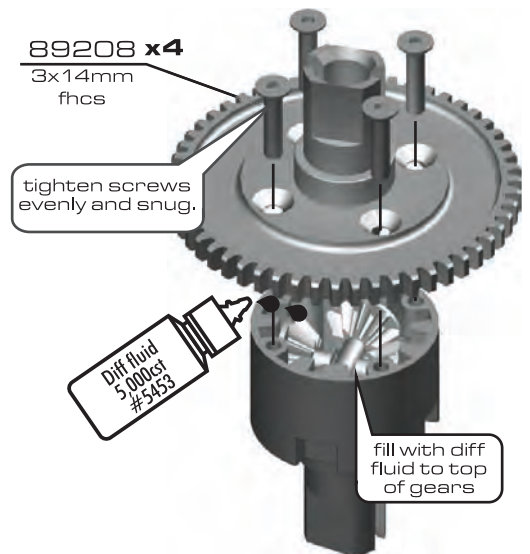
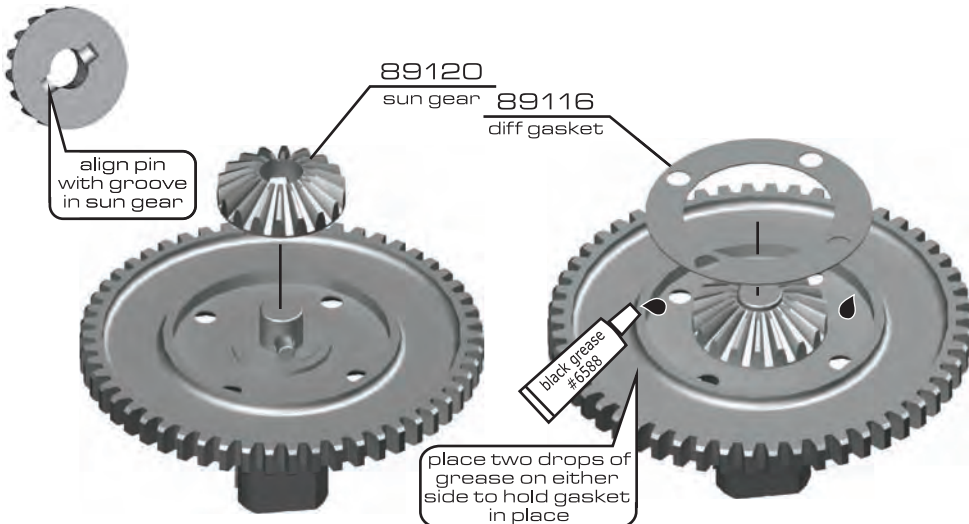

:: Servo Turnbuckle

BAG B

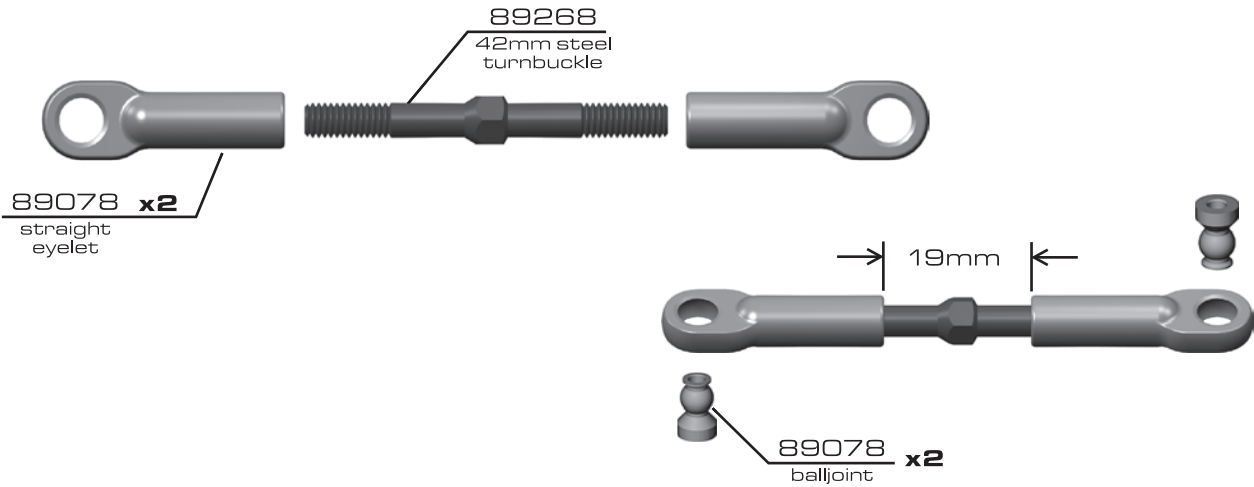

:: Steering Turnbuckles

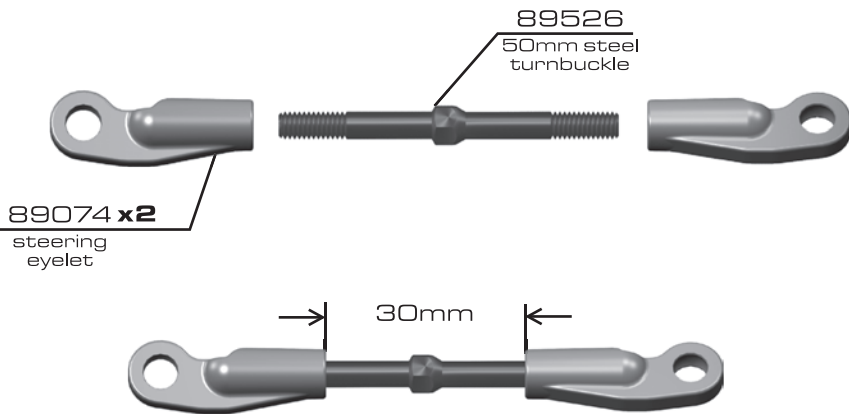

Builds X2

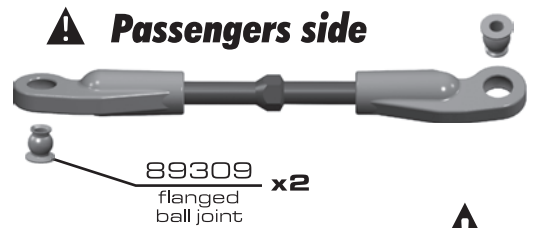

▲
*note the direction of
the turnbuckles during
installation!



:: Camber Turnbuckles

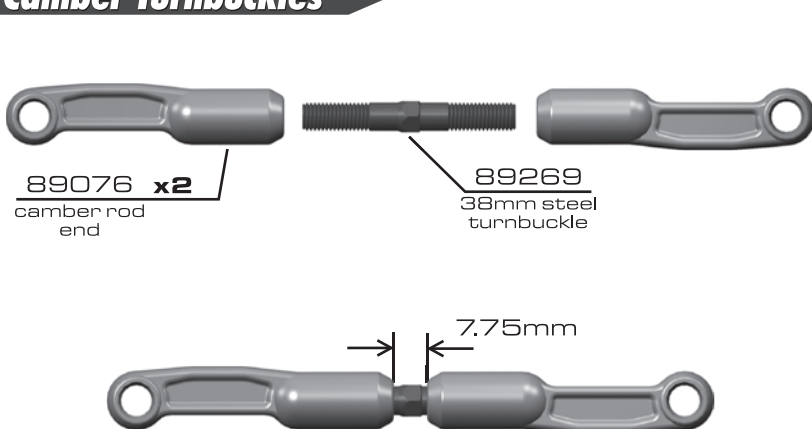

Builds X2



▲
*note the direction of
the turnbuckles during
installation!



:: Shocks

BAG C

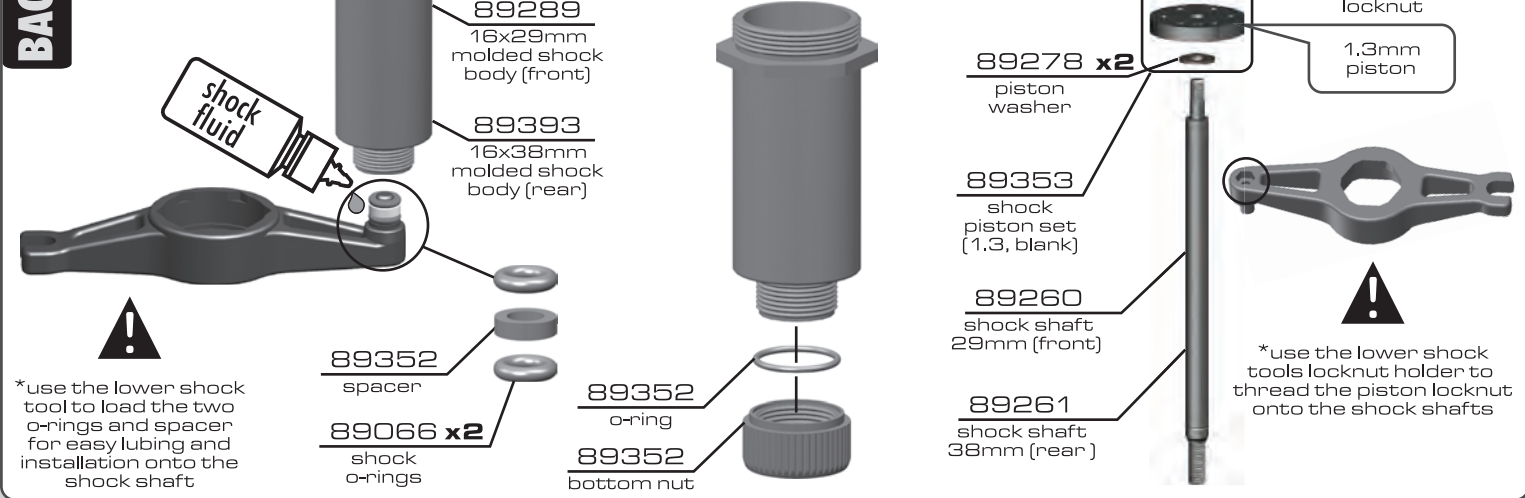

:: Shocks (cont.)

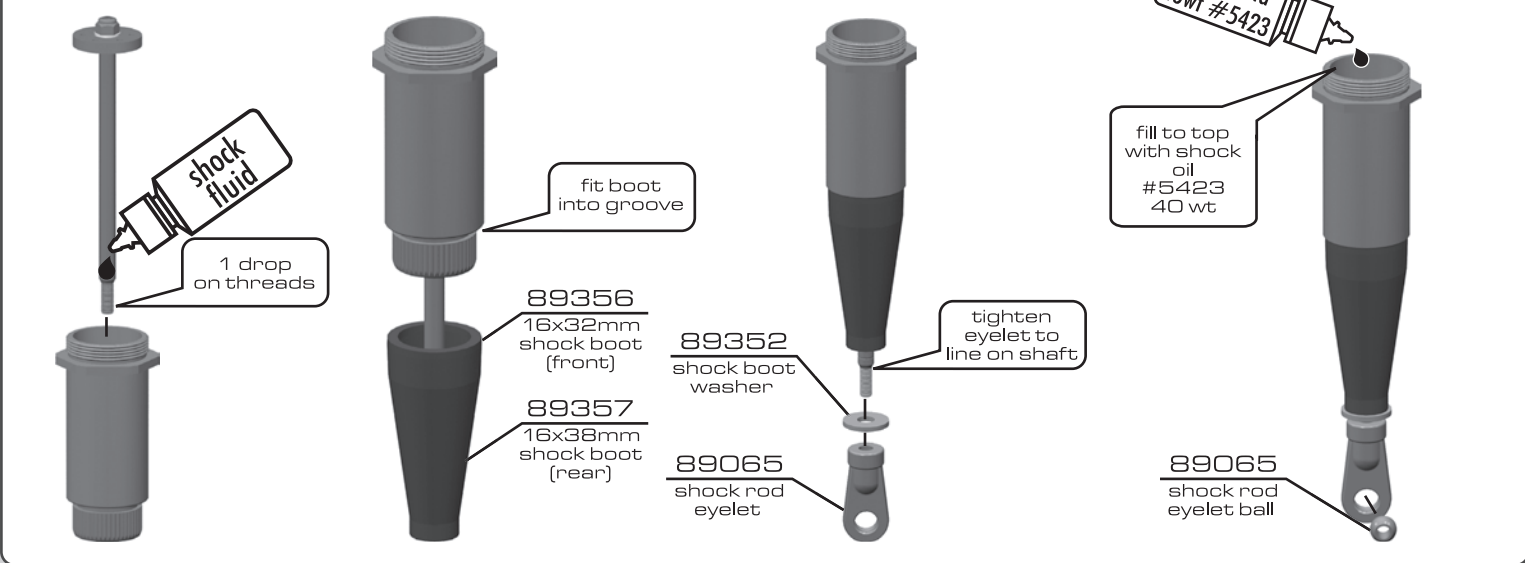

:: Shocks (cont.)

Bladder installation

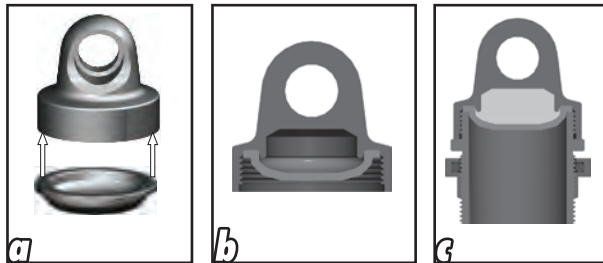

As you install the cap with bladder, it will force out any extra oil. If you install the cap with the shaft fully extended, you are running FULL REBOUND.
To run less rebound, unthread the cap 1-2 turns and compress the shaft to the desired position and re-tighten the cap.

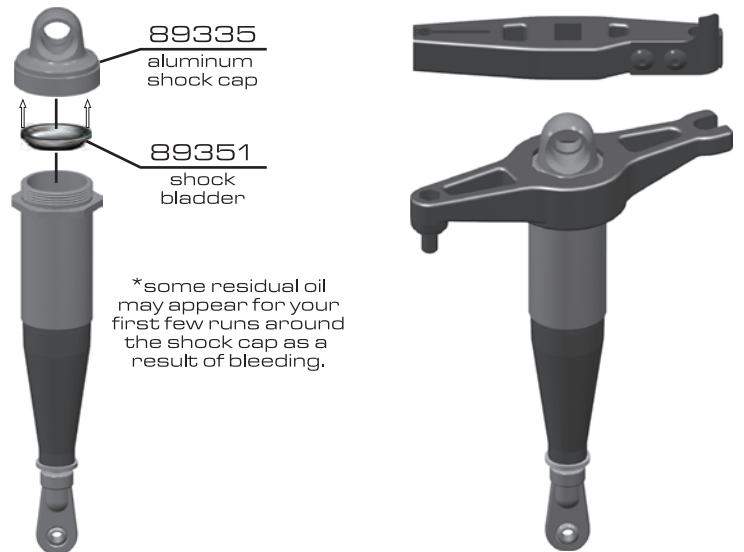

:: Shocks (cont.)

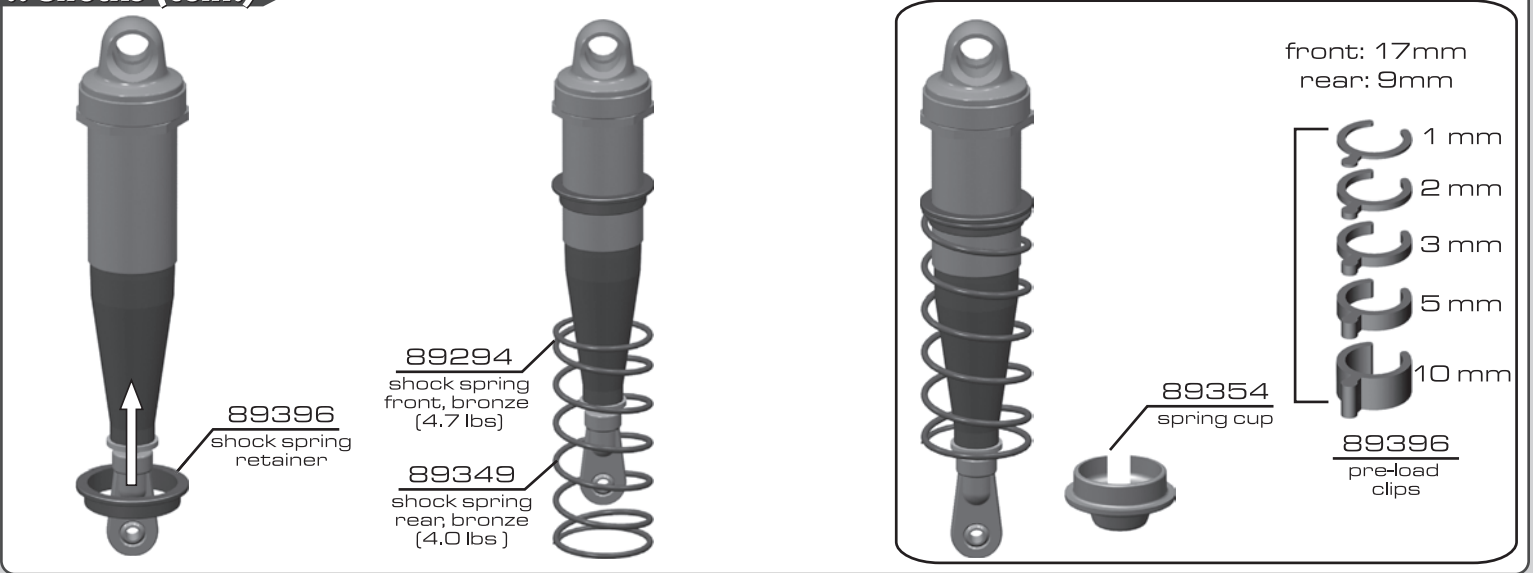

:: Steering

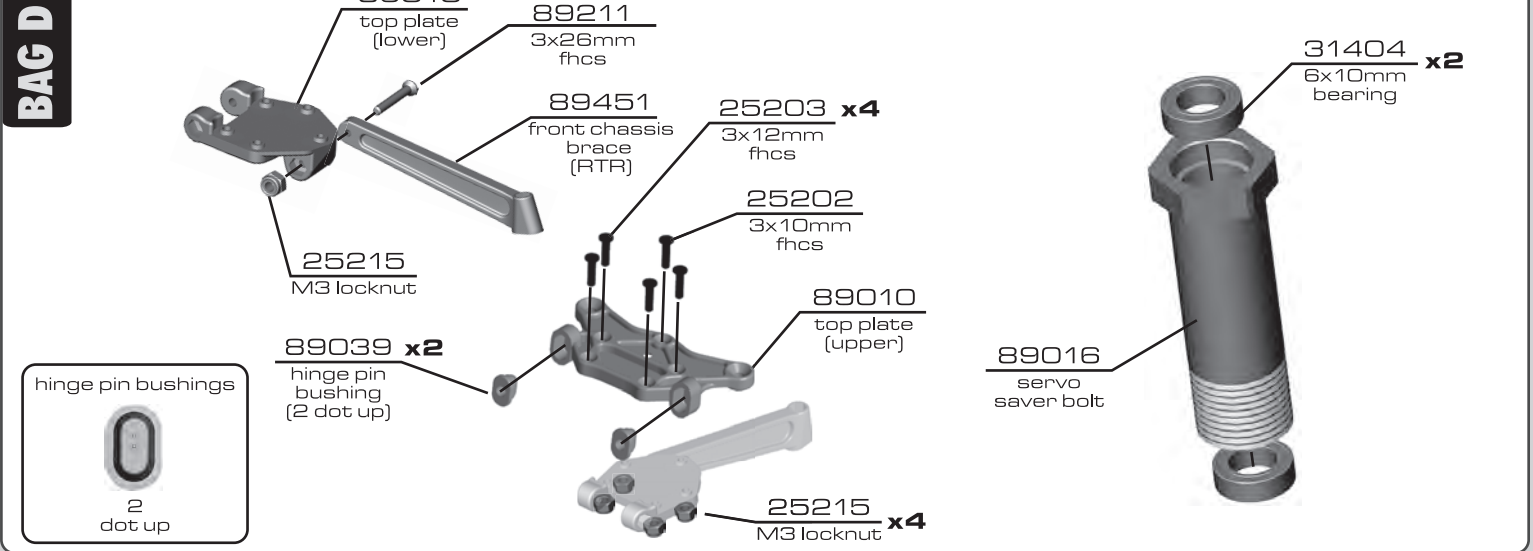

:: Steering (cont.)

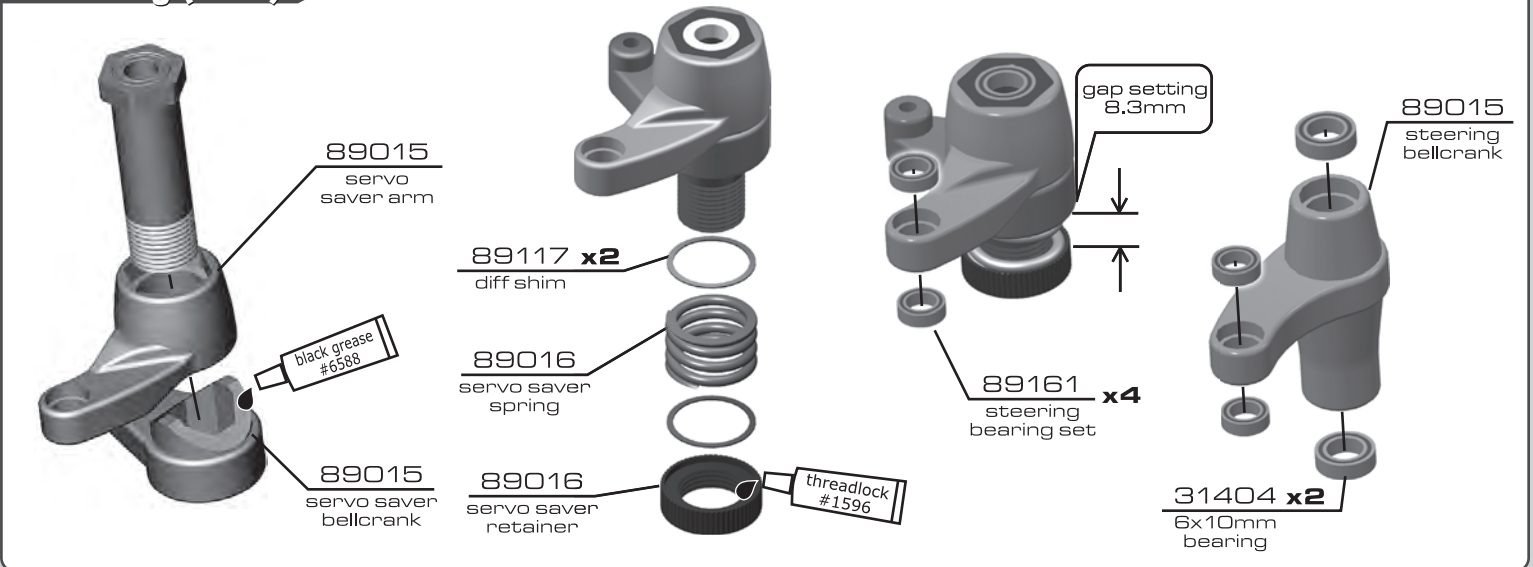

:: Steering (cont.)

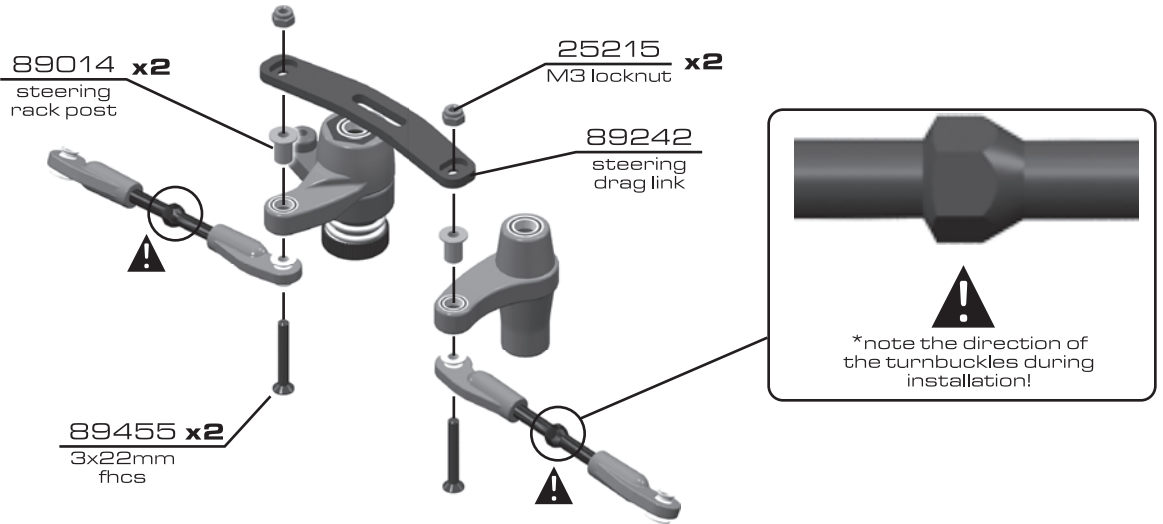

:: Steering (cont.)

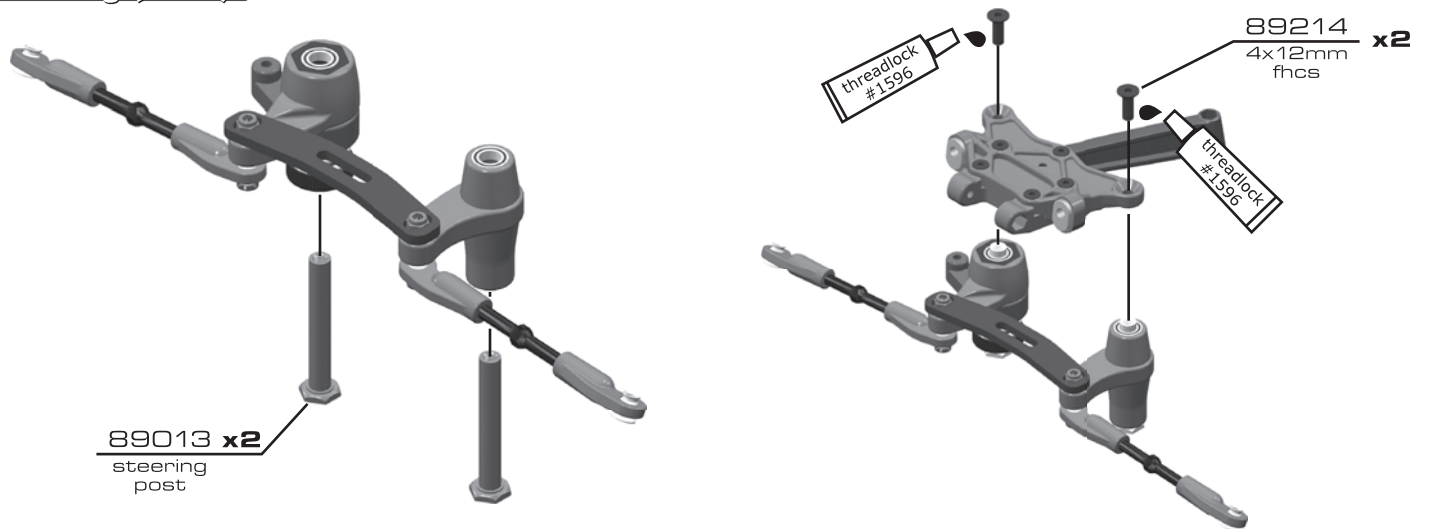

:: Front Gearbox

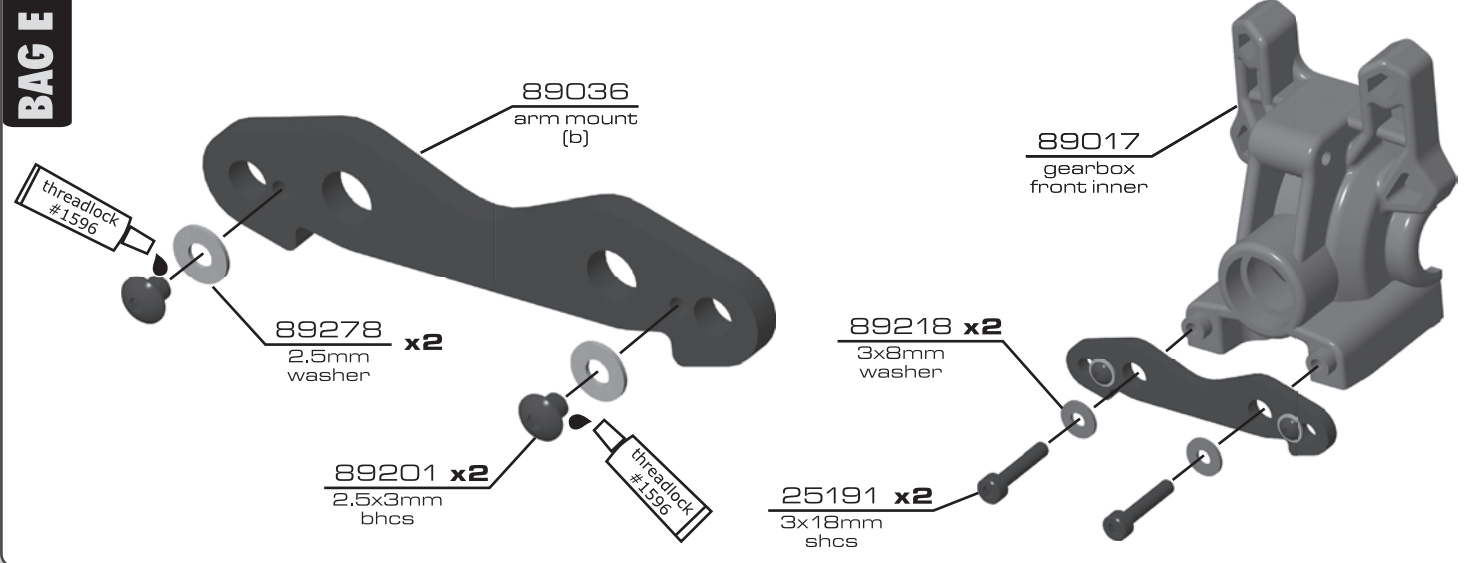

:: Front Gearbox (cont.)

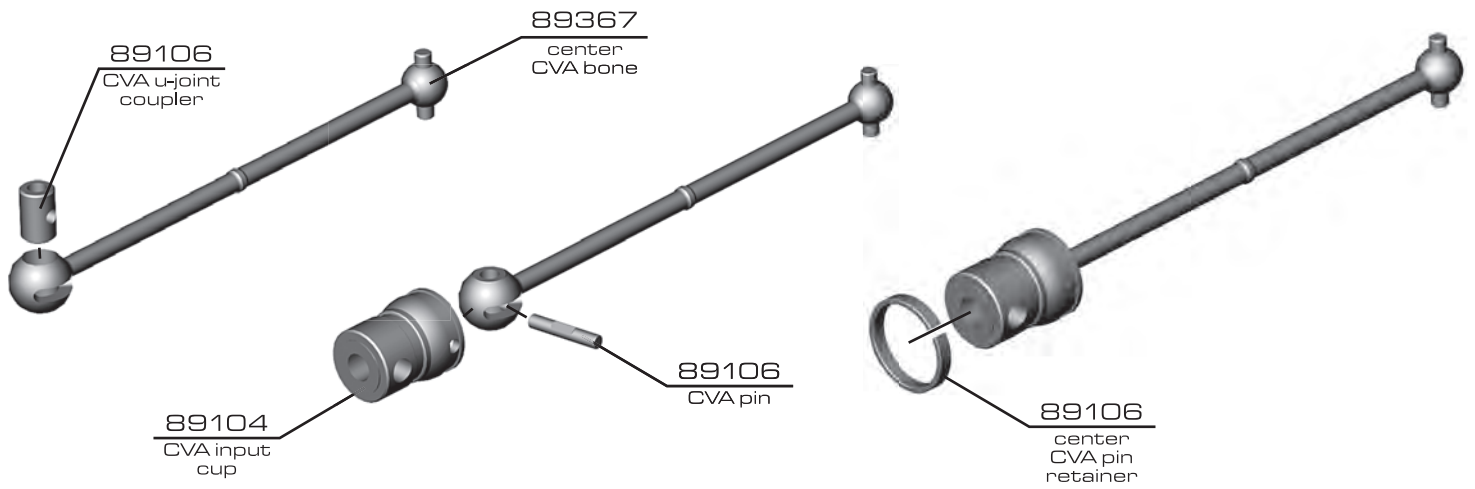

:: Front Gearbox (cont.)

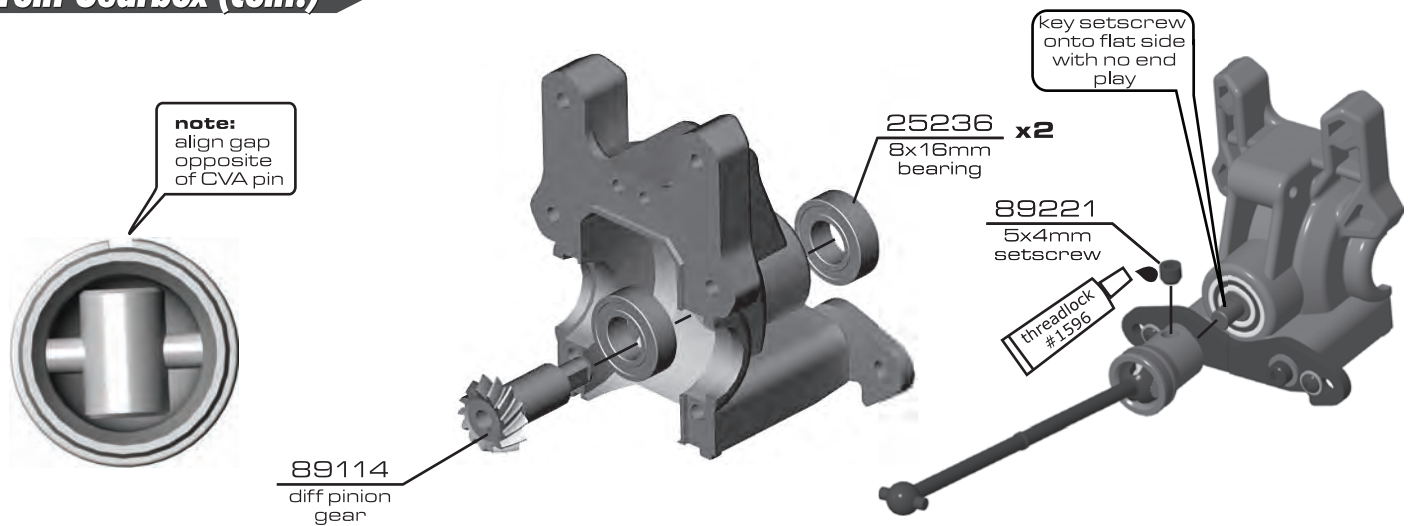

:: Front Gearbox (cont.)

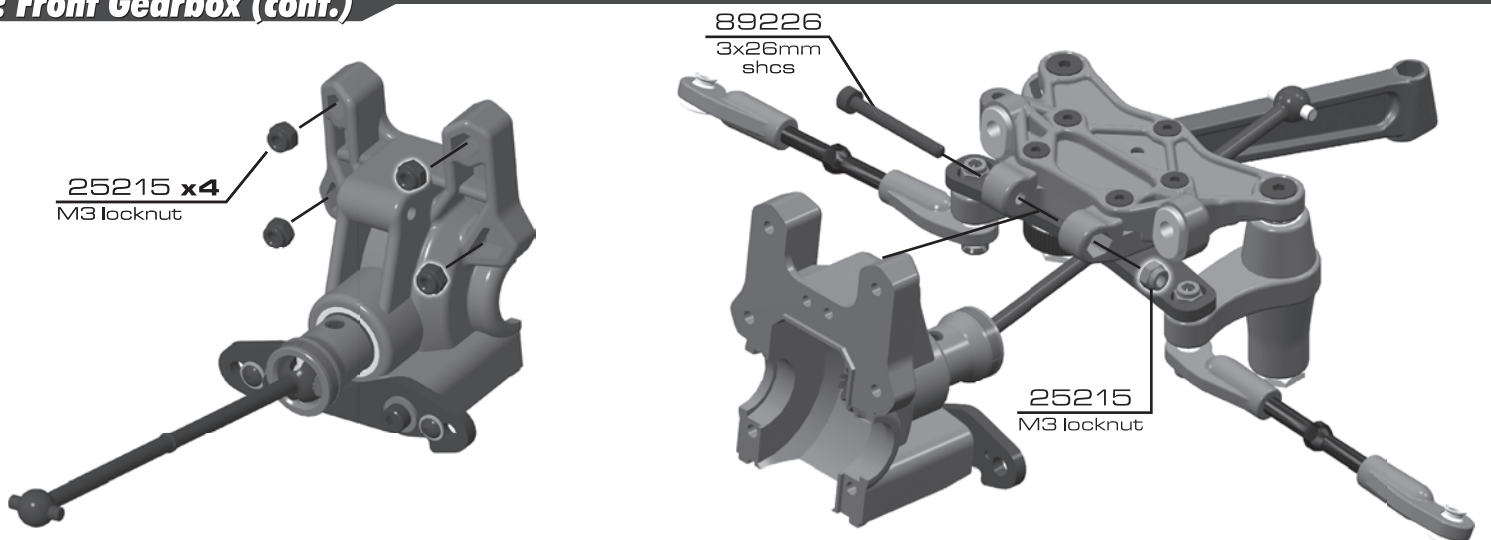

:: Front Gearbox (cont.)

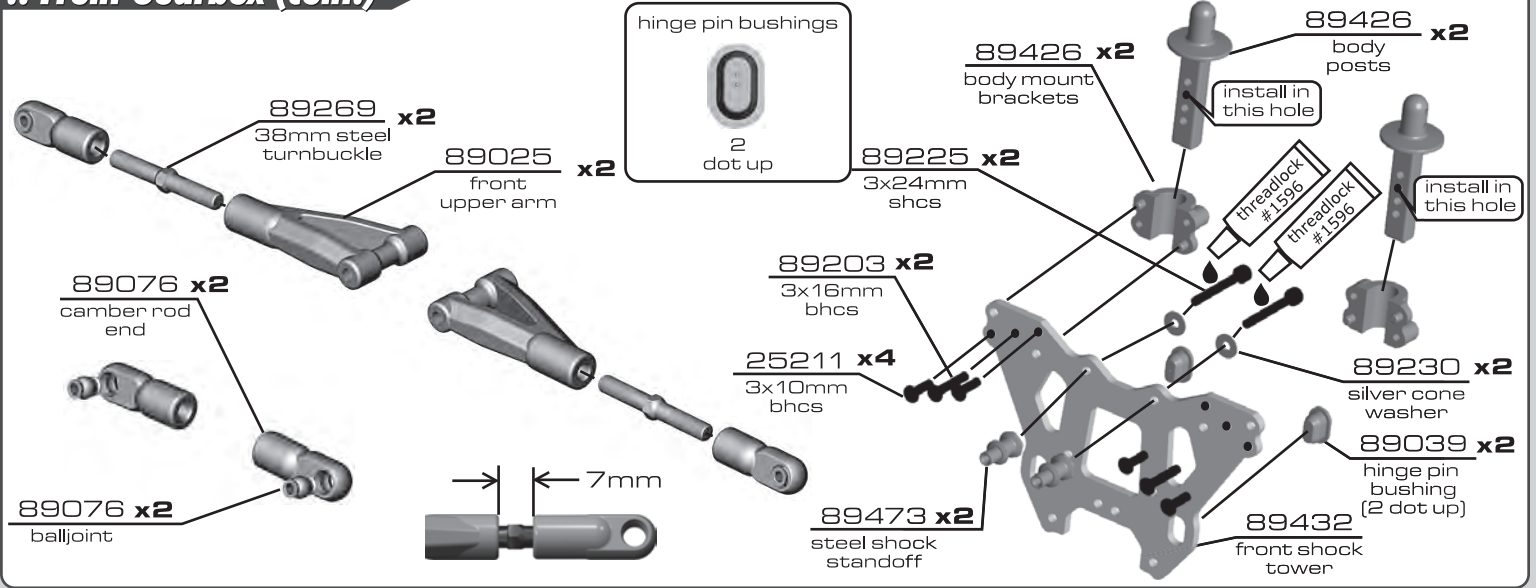

:: Front Gearbox (cont.)

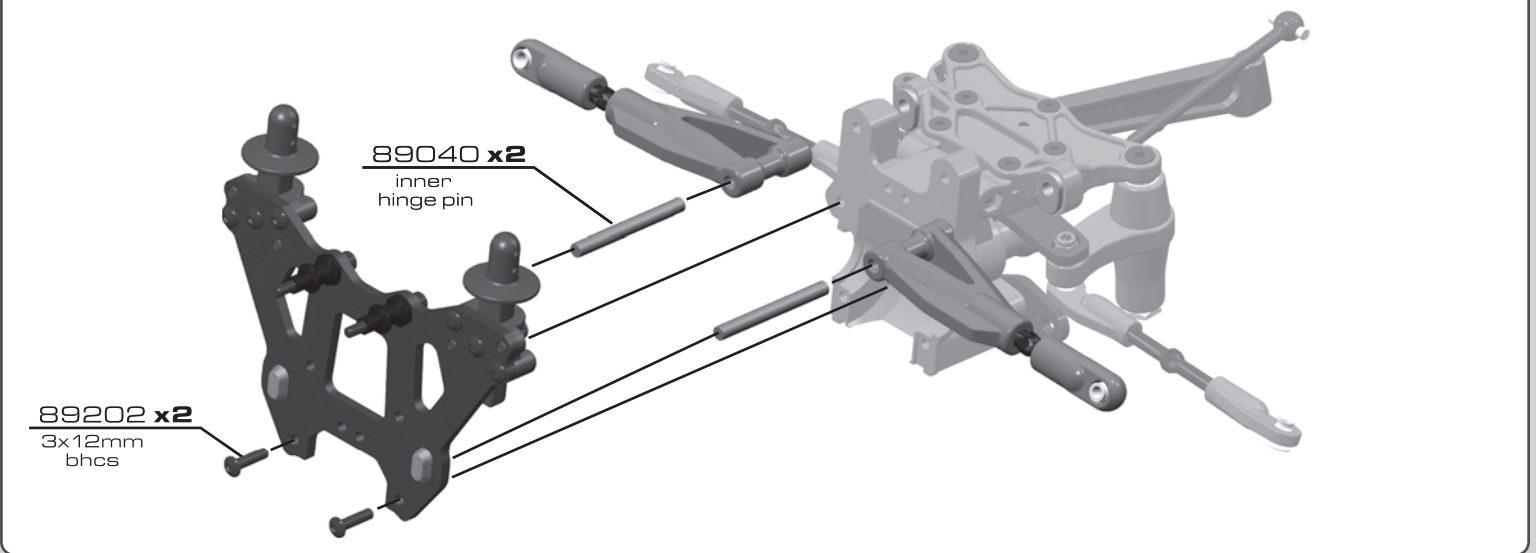

:: Front Gearbox (cont.)

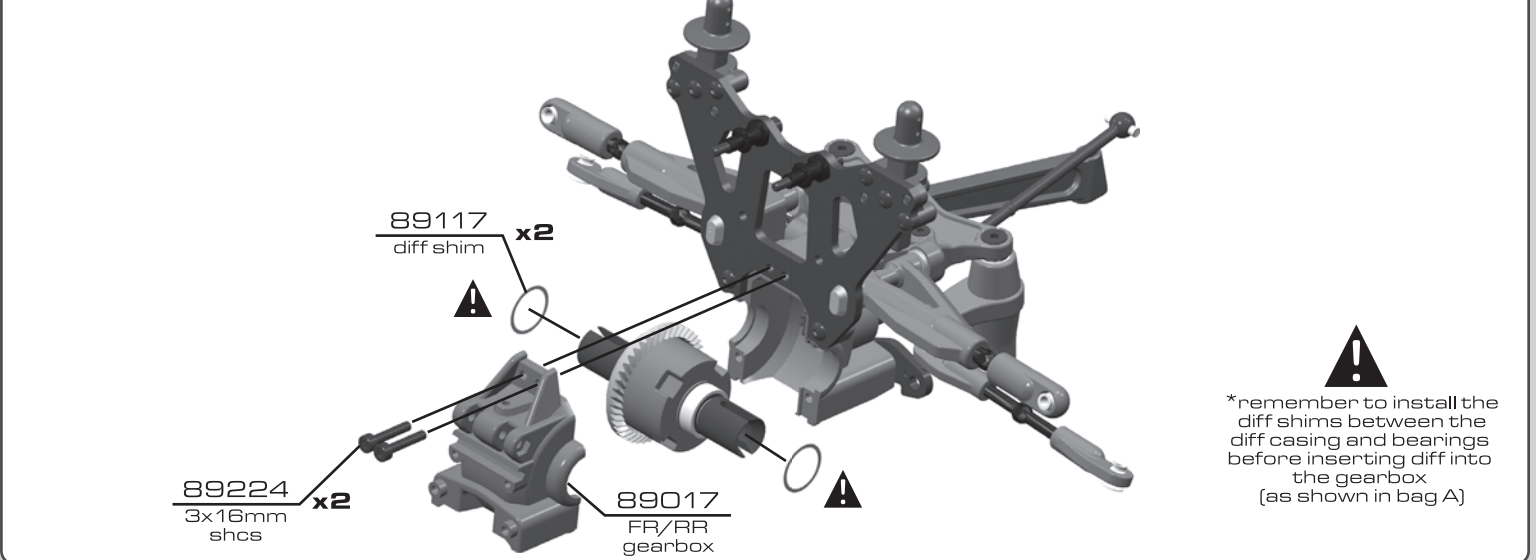

:: Suspension

BAG F

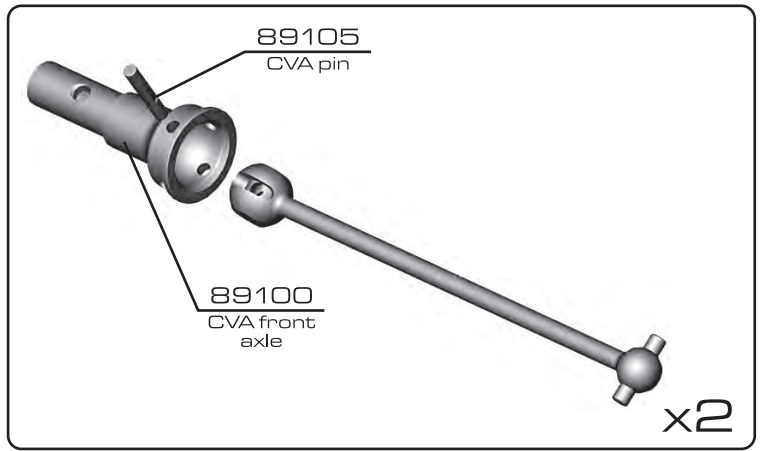
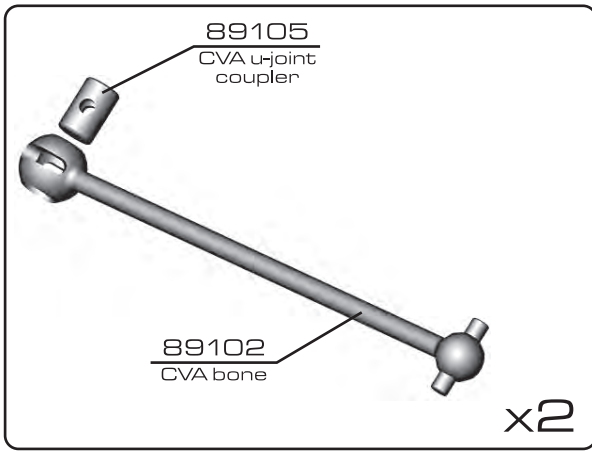

:: Suspension (cont.)

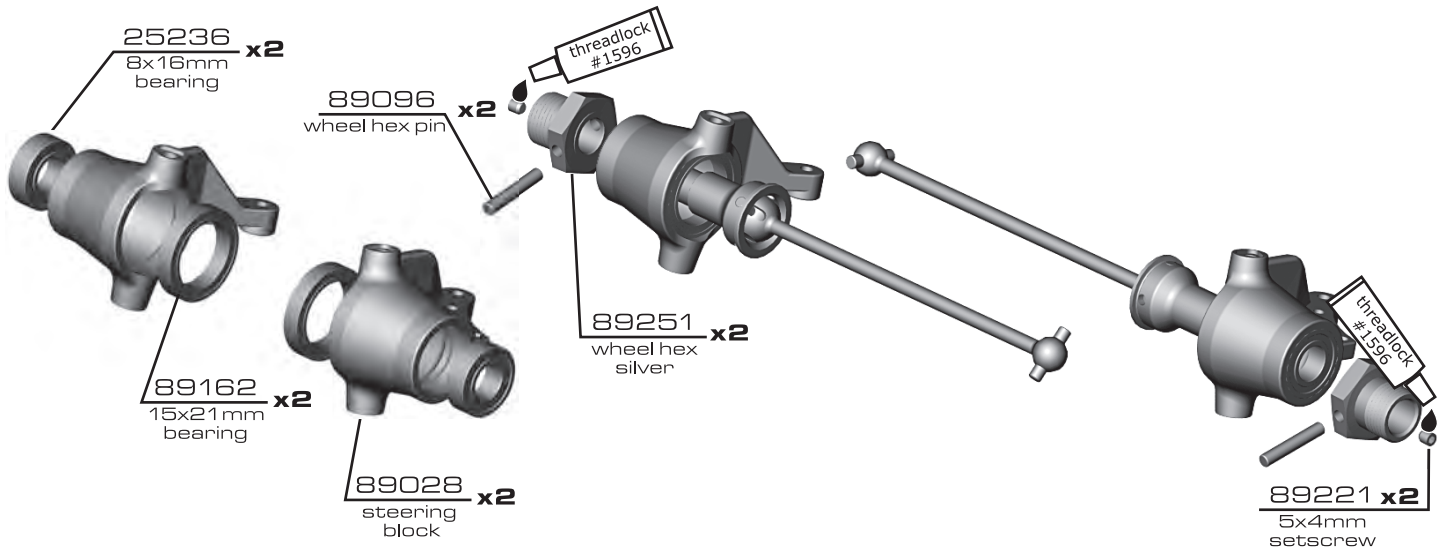

:: Suspension (cont.)

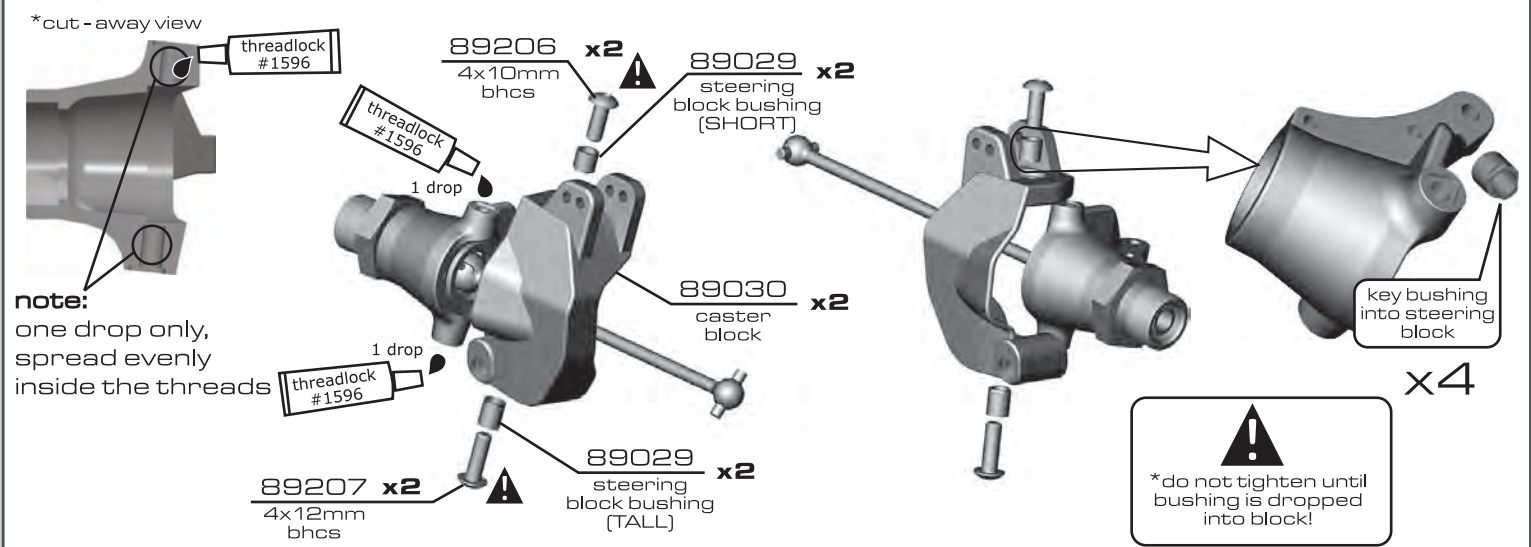

:: Suspension (cont.)

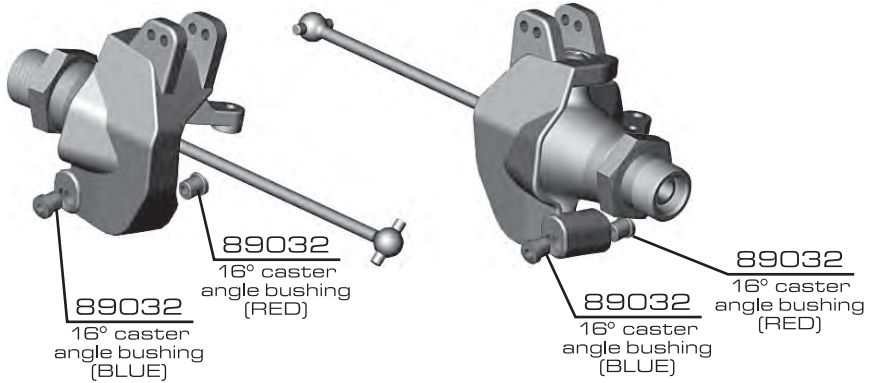
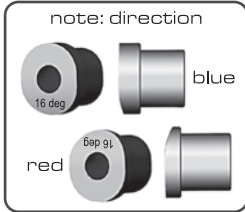

:: Suspension (cont.)

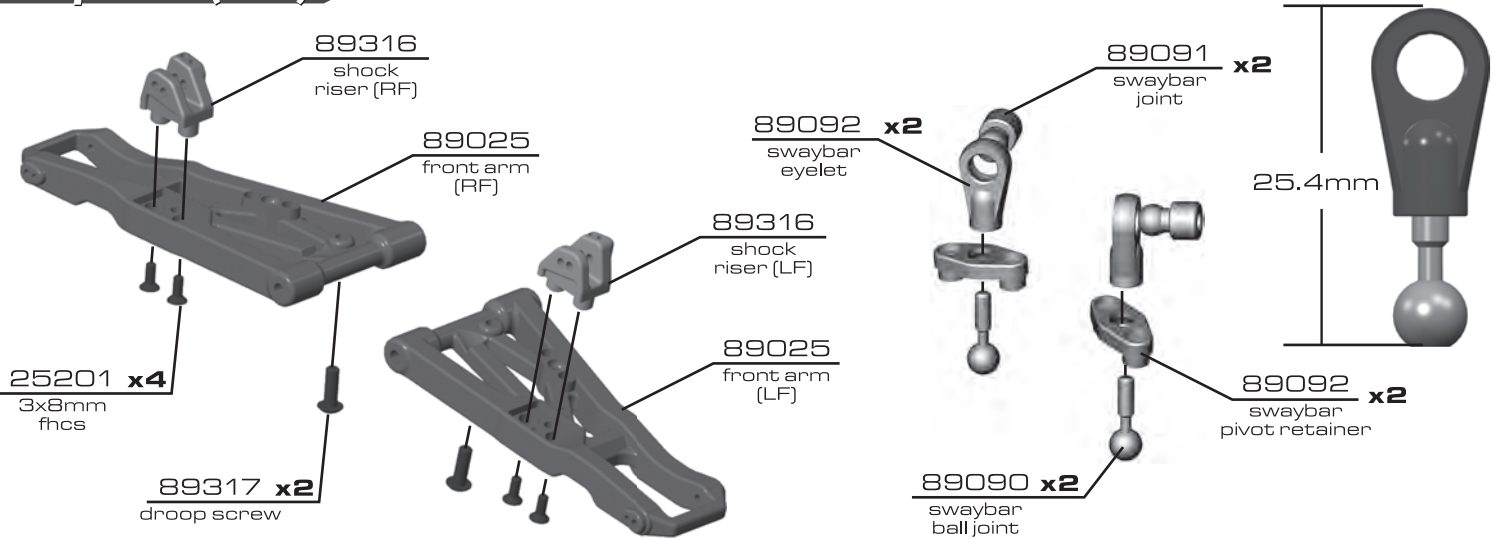

:: Suspension (cont.)

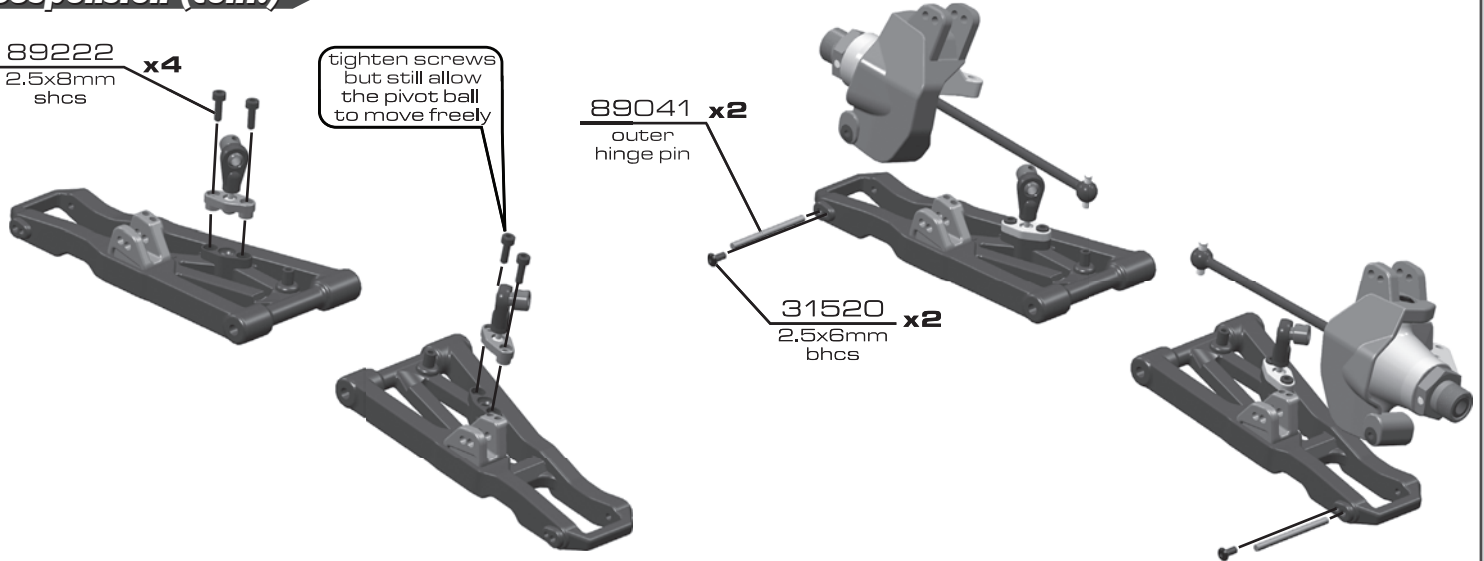

:: Suspension (cont.)

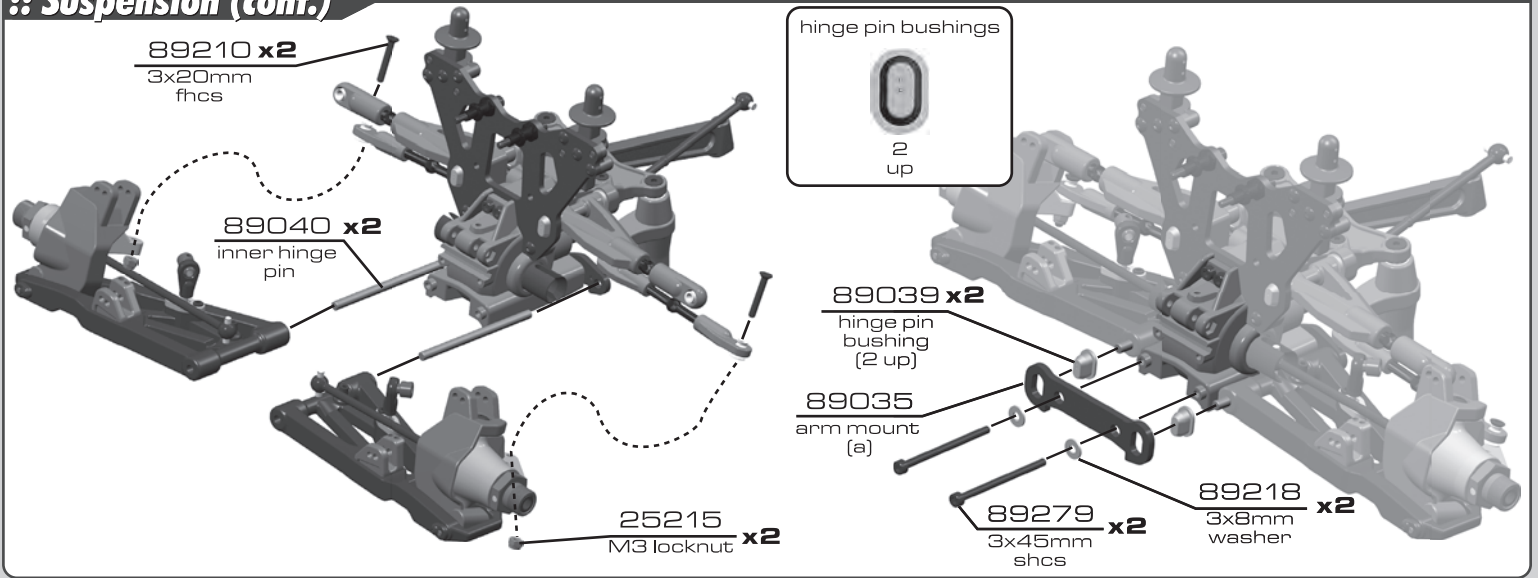

:: Suspension (cont.)

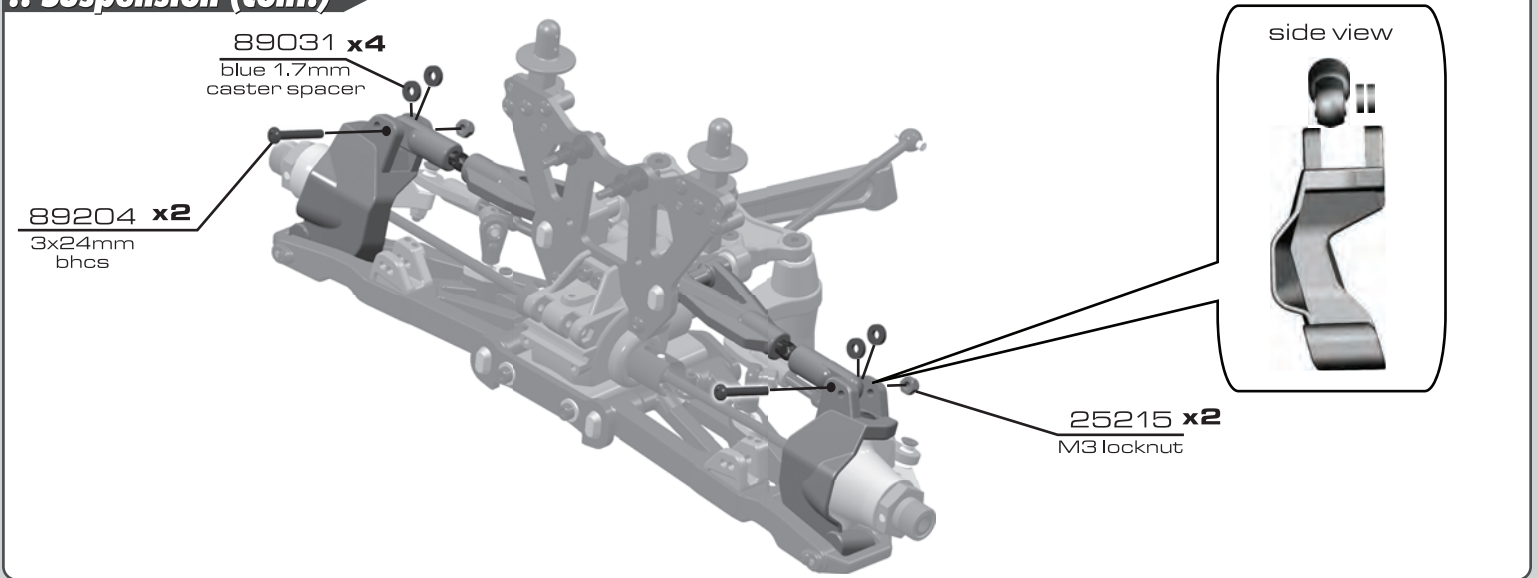

:: Suspension (cont.)

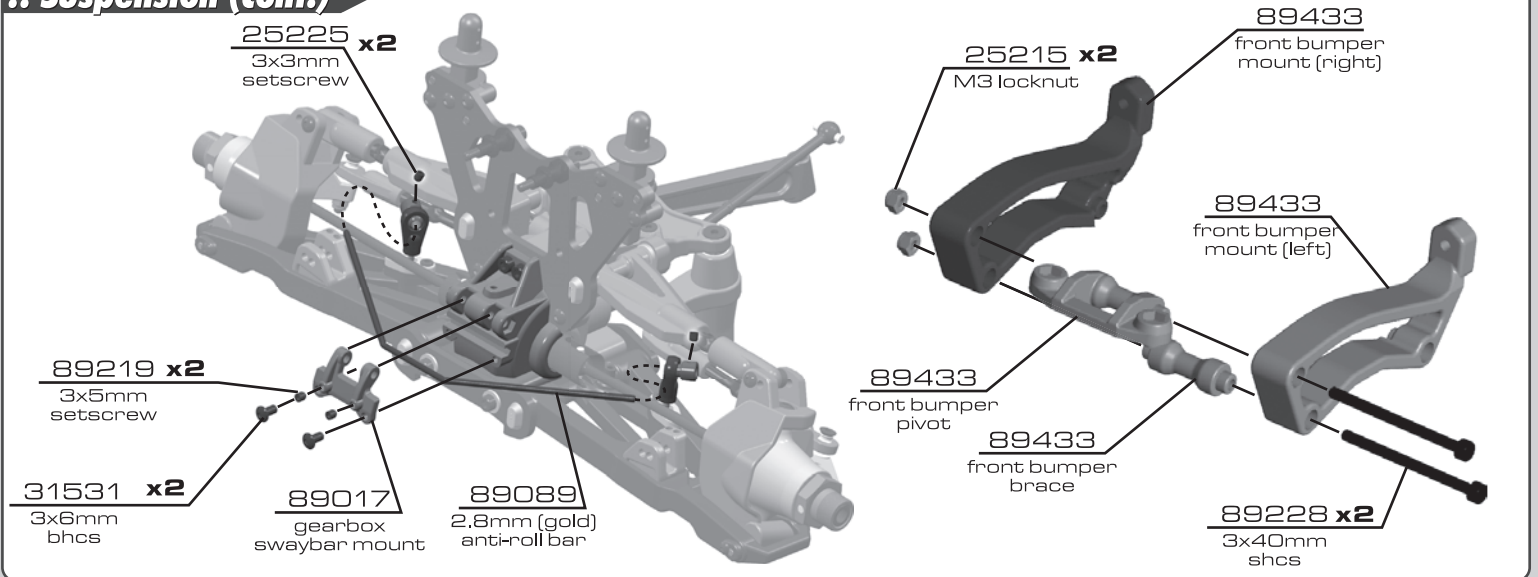

:: Suspension (cont.)

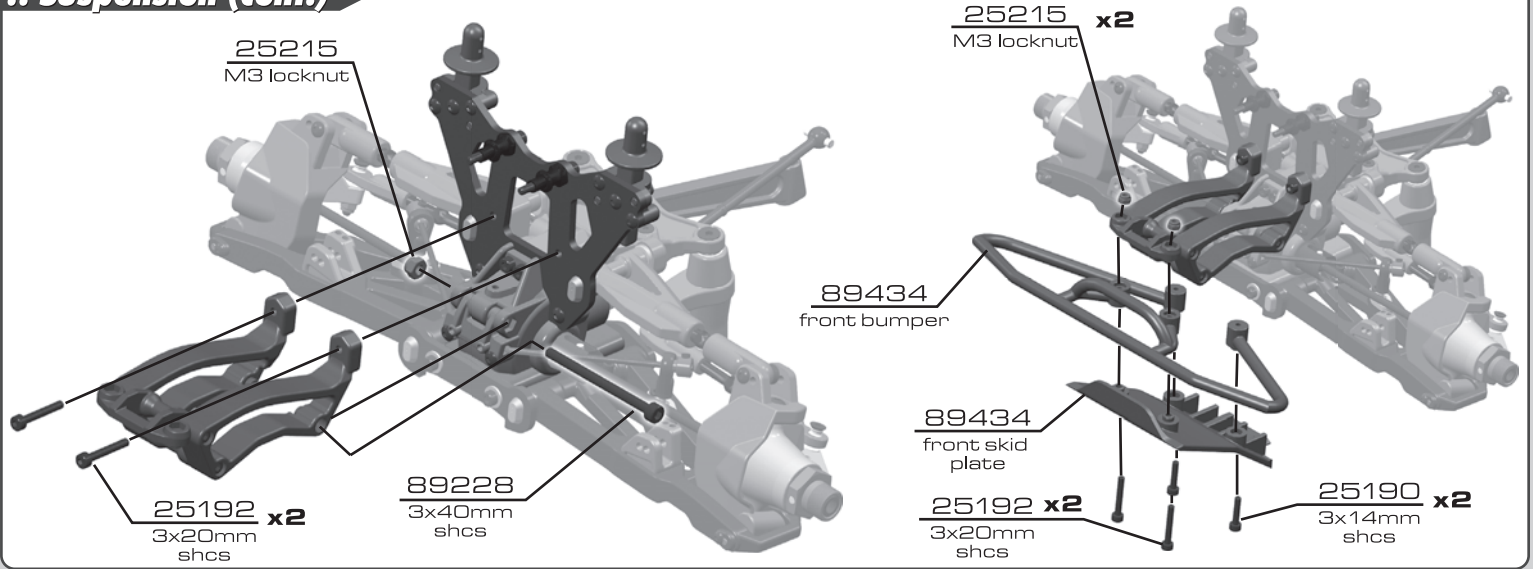

:: Suspension (cont.)

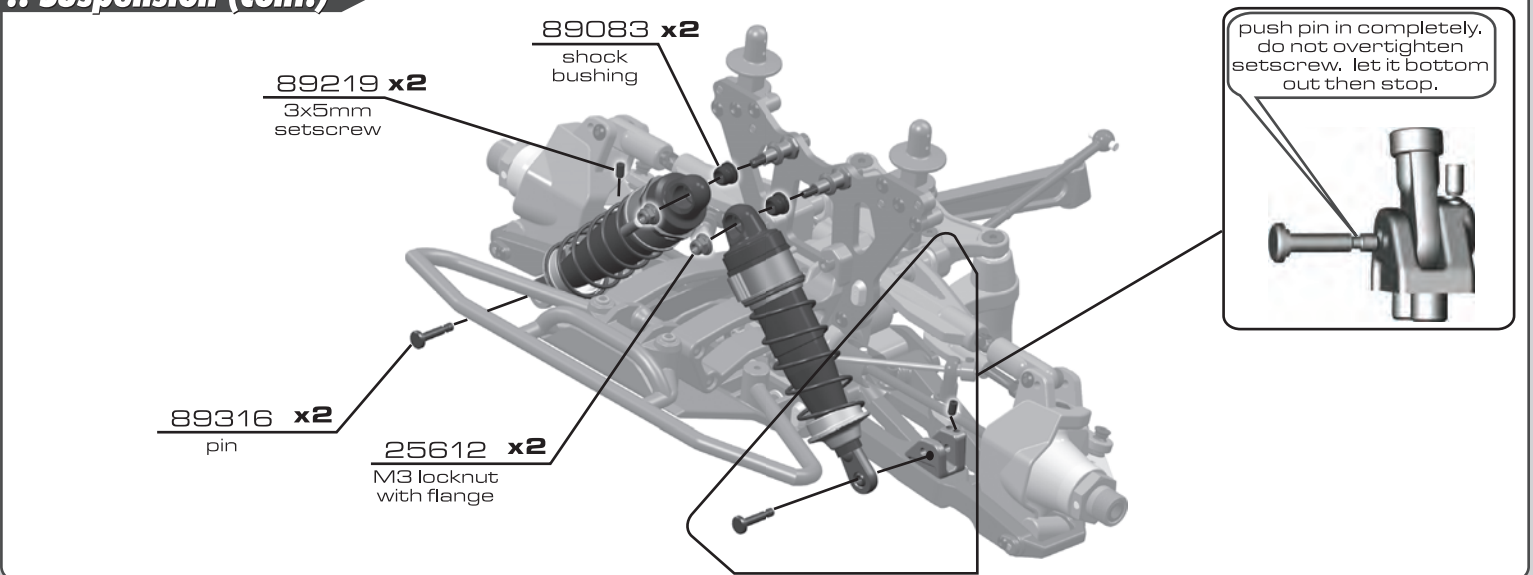

:: Rear Gearbox

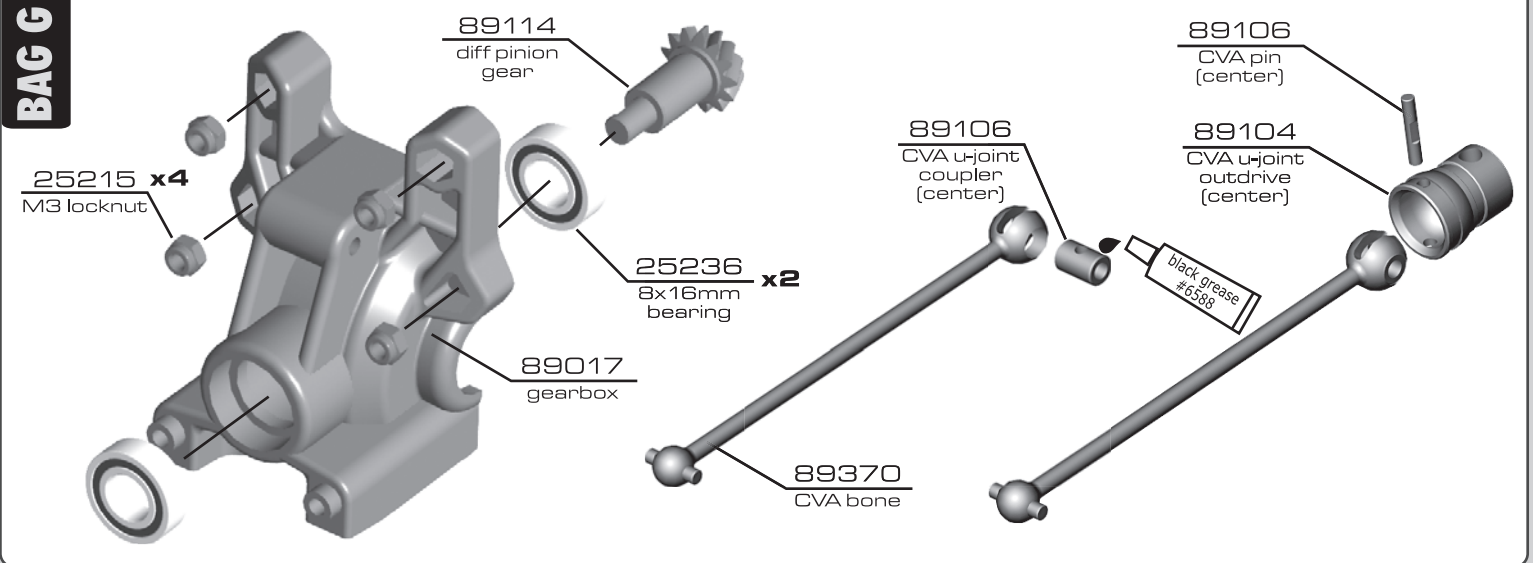

:: Rear Gearbox (cont.)

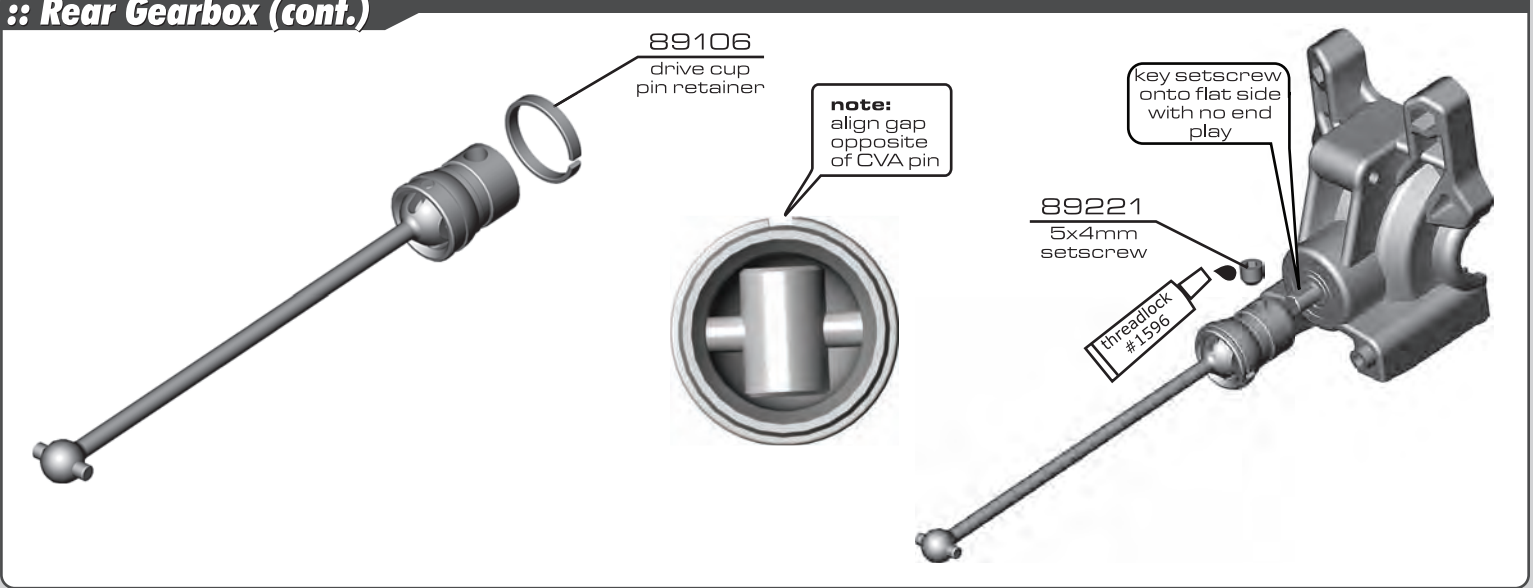

:: Rear Gearbox (cont.)

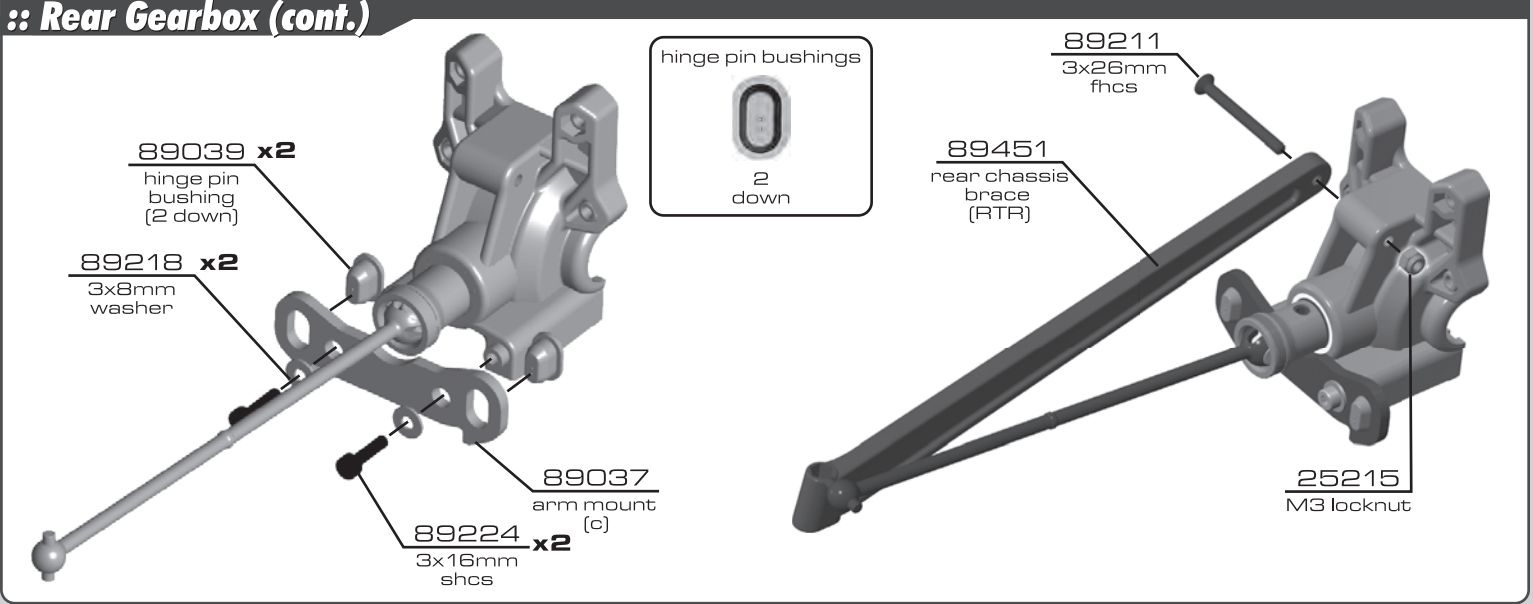

:: Rear Gearbox (cont.)

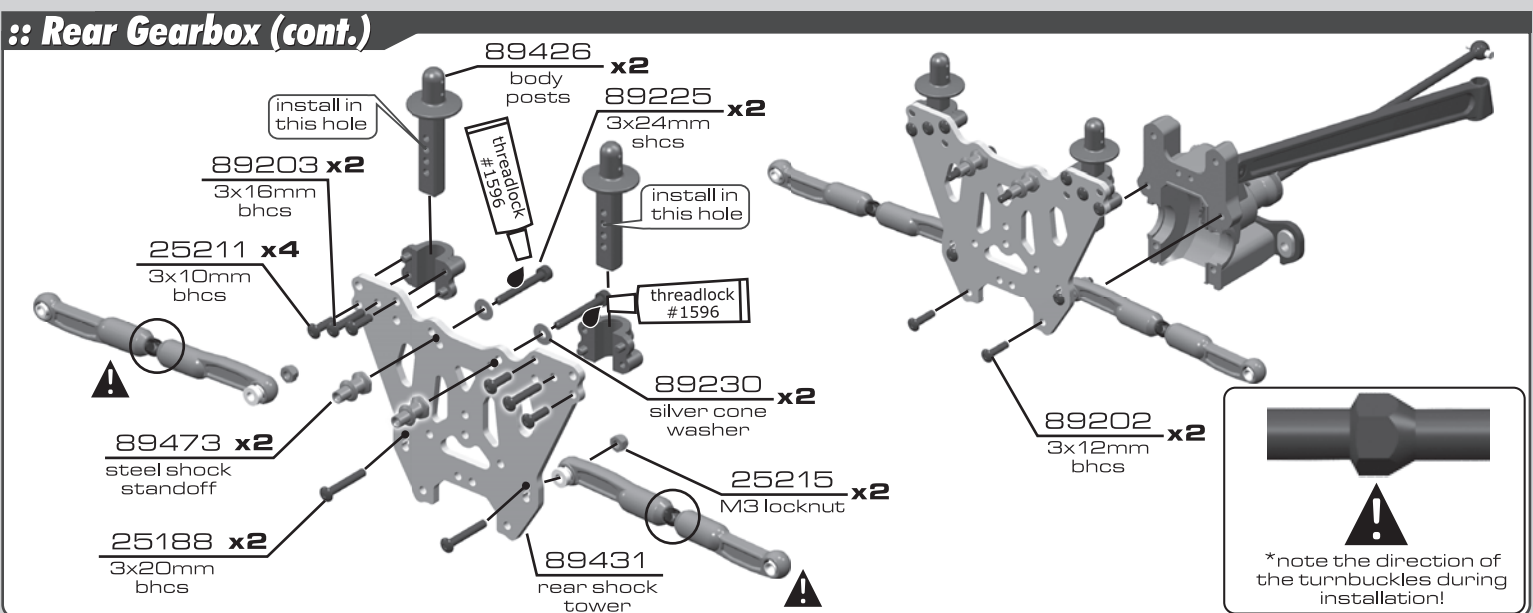

:: Rear Gearbox (cont.)

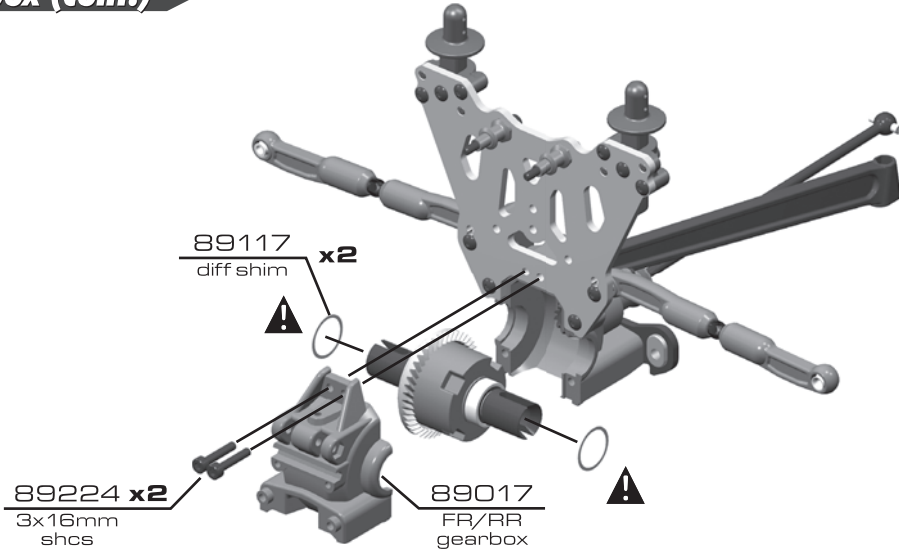

!
*remember to install the diff shims between the diff casing and bearings before inserting diff into the gearbox (as shown in bag A)

:: Suspension

BAG H

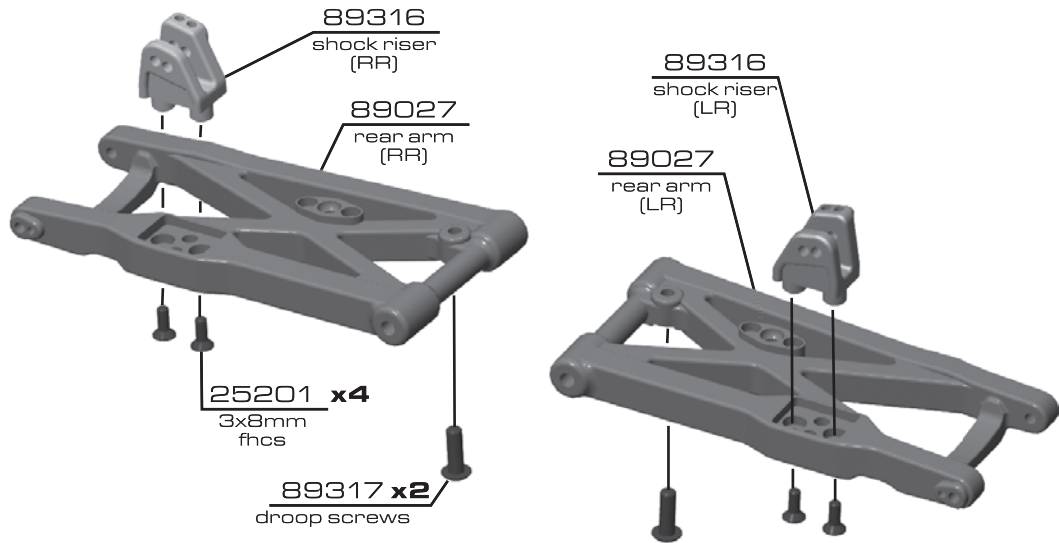

:: Suspension (cont.)

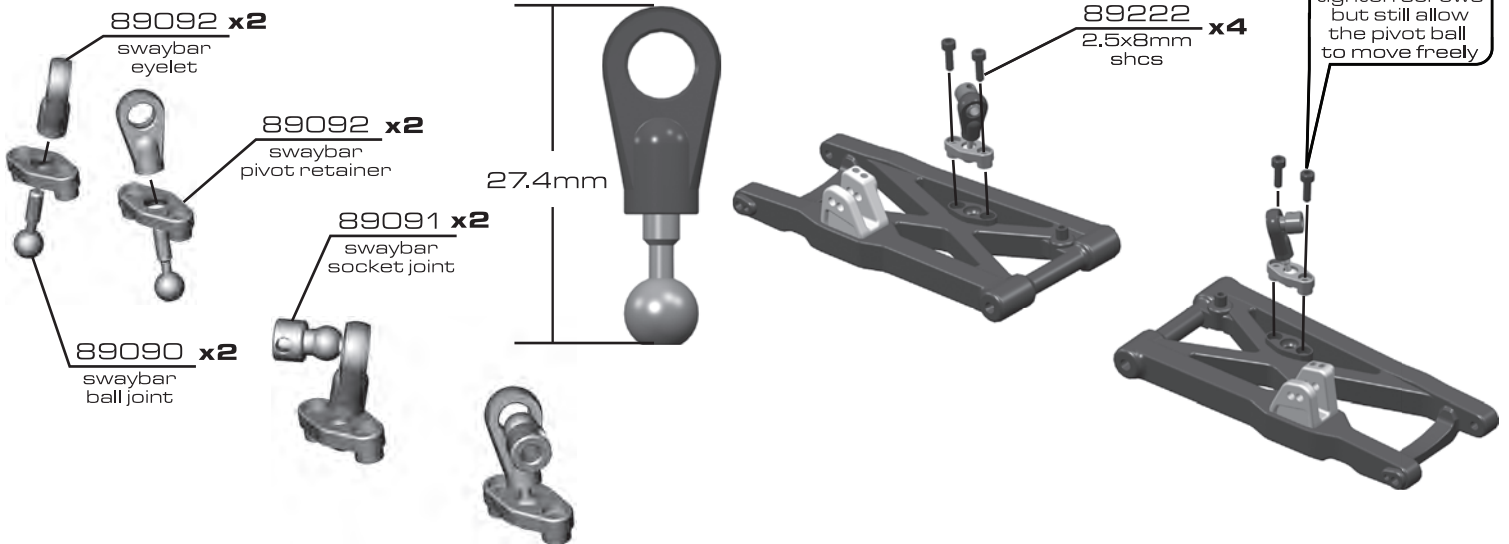

:: Suspension (cont.)

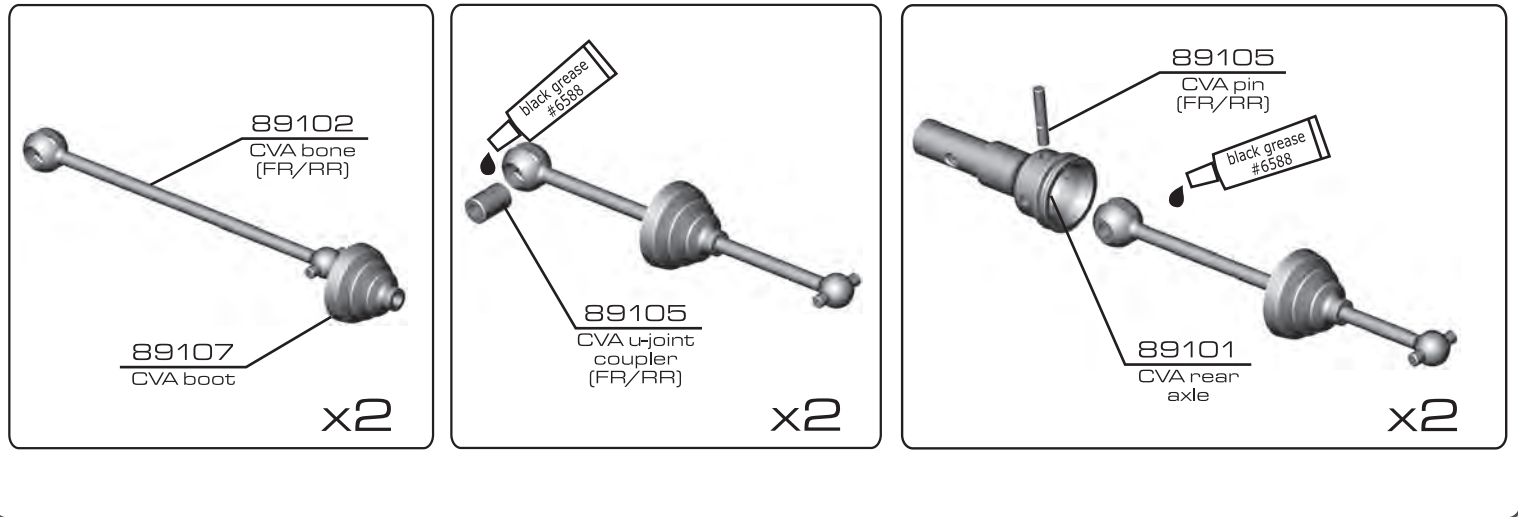

:: Suspension (cont.)

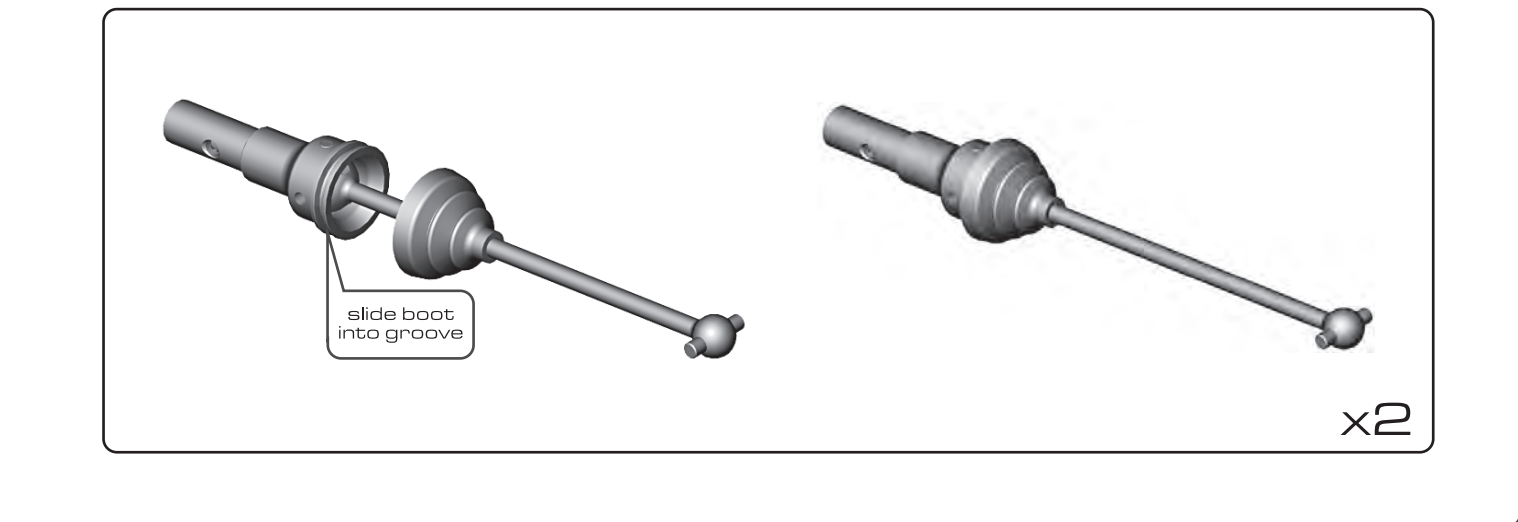

:: Suspension (cont.)

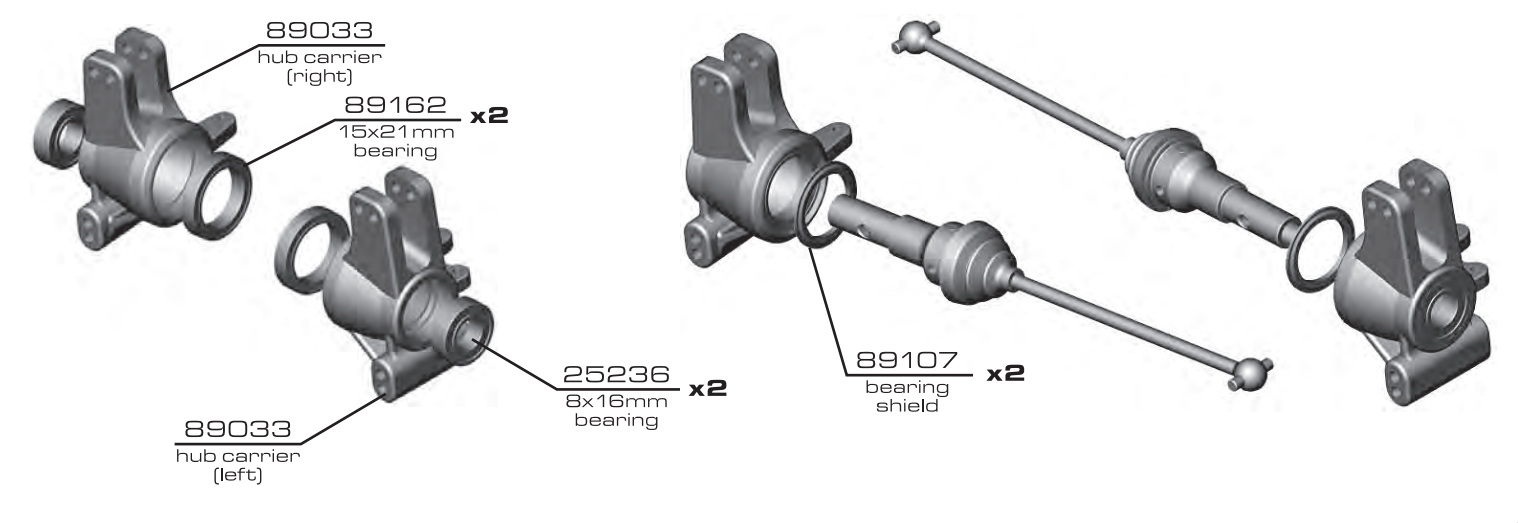

:: Suspension (cont.)

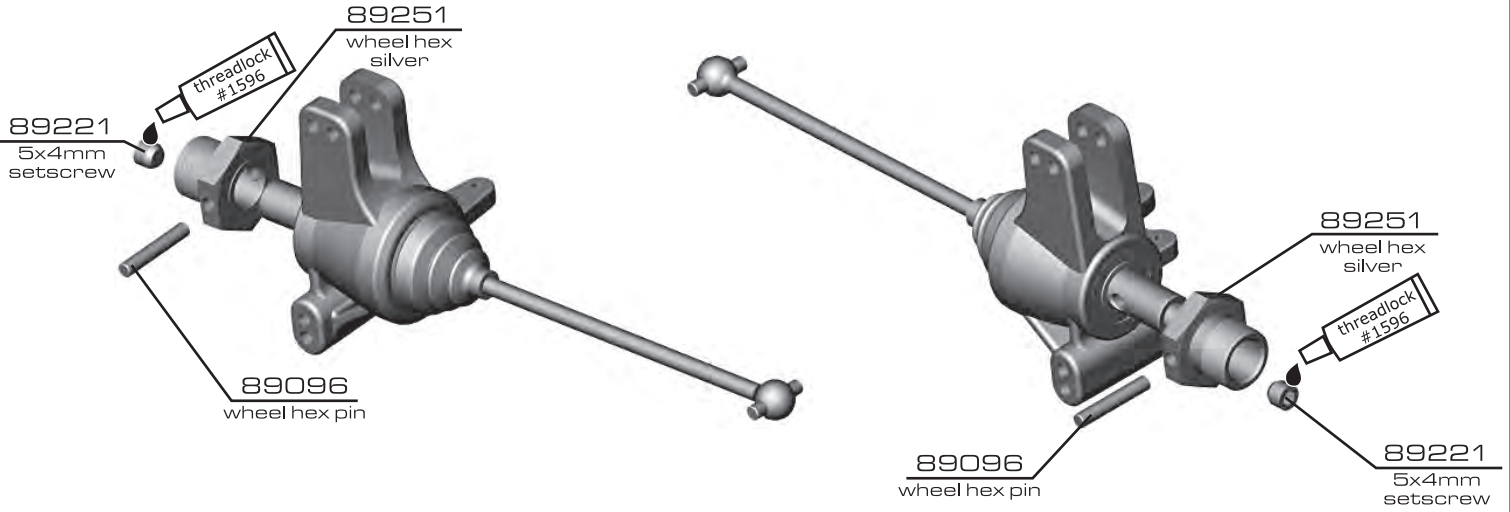

:: Suspension (cont.)

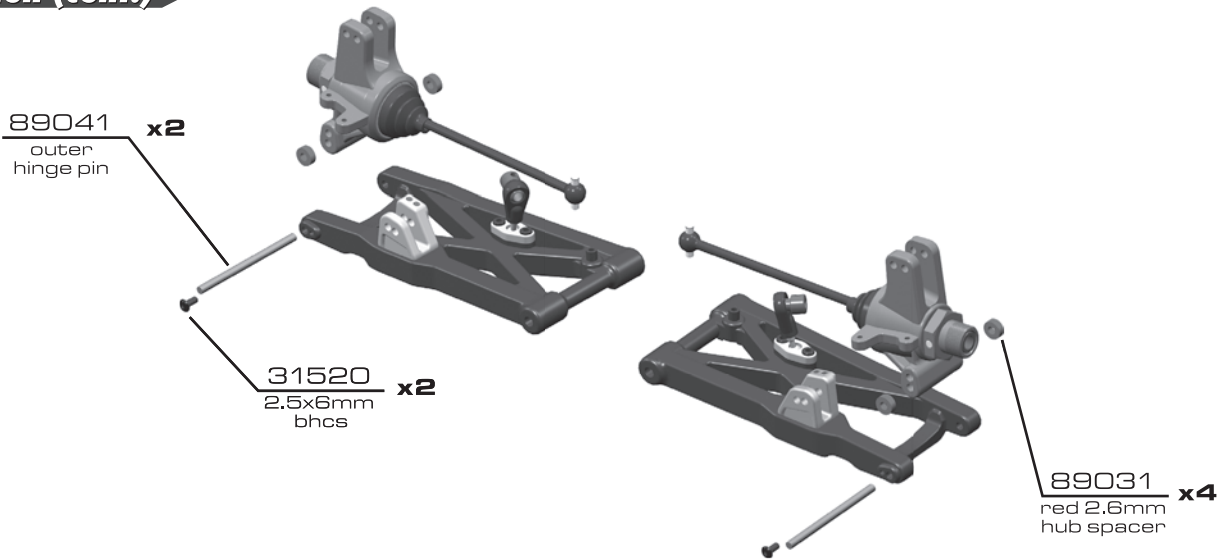

:: Suspension (cont.)

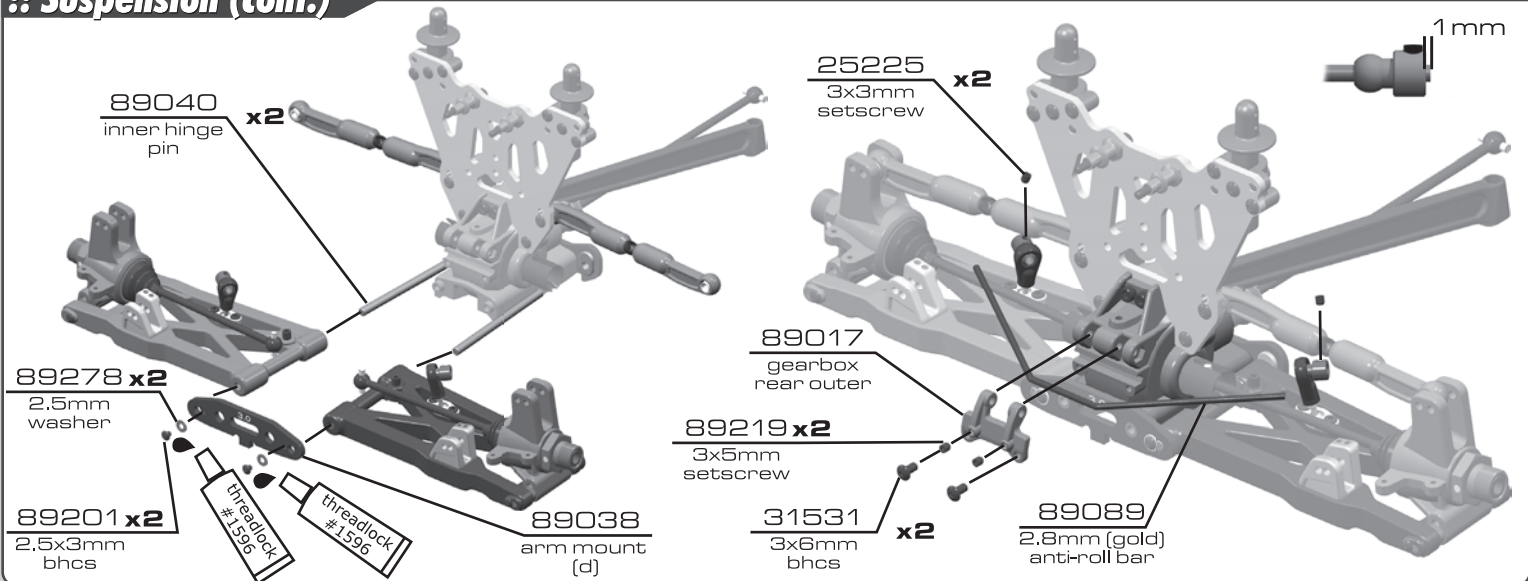

:: Suspension (cont.)

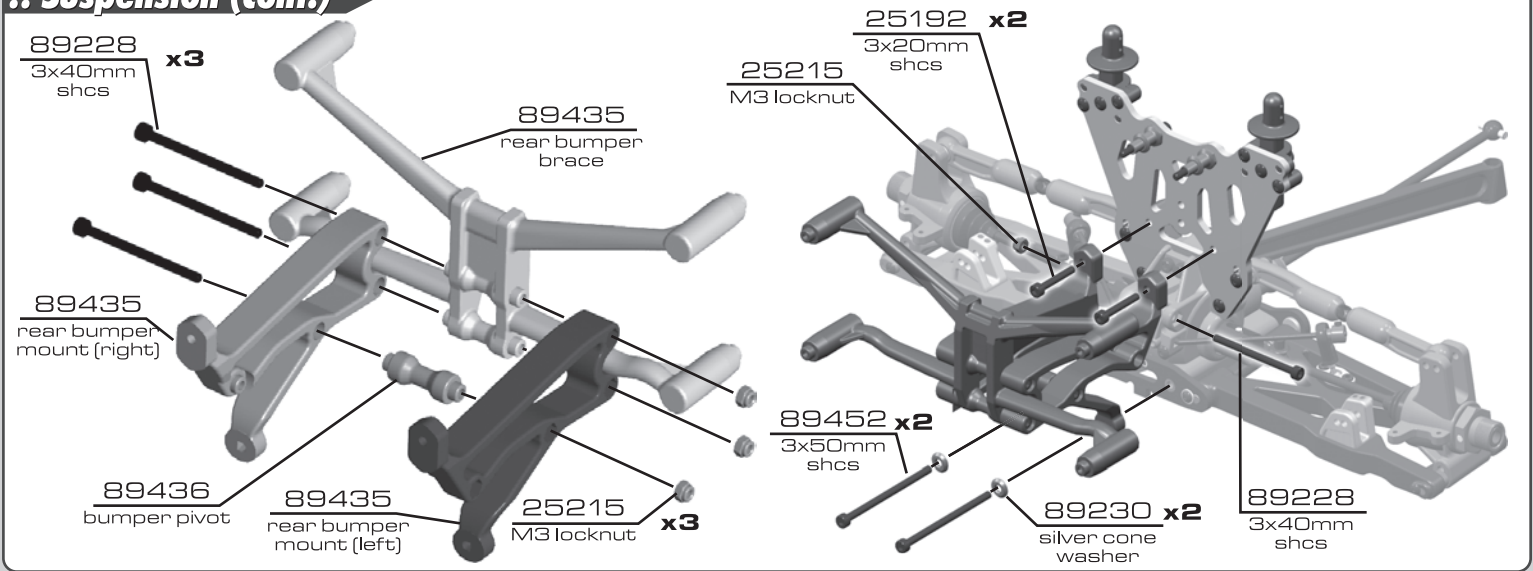

:: Suspension (cont.)

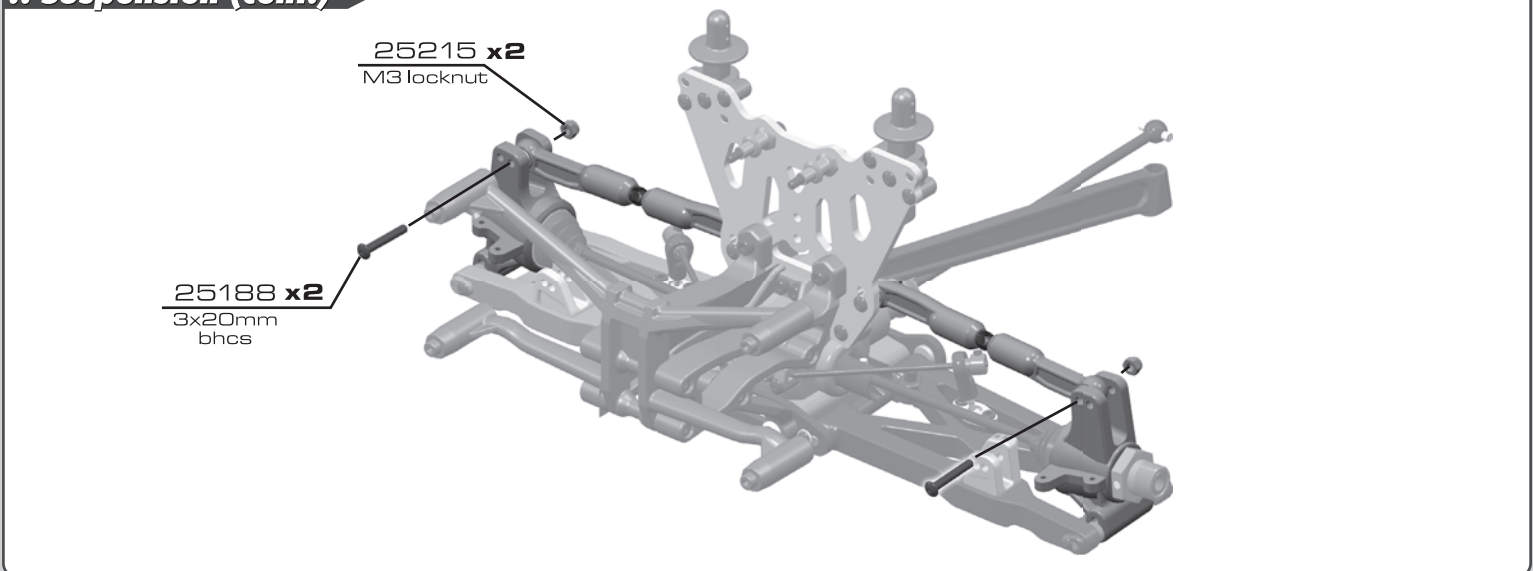

:: Suspension (cont.)

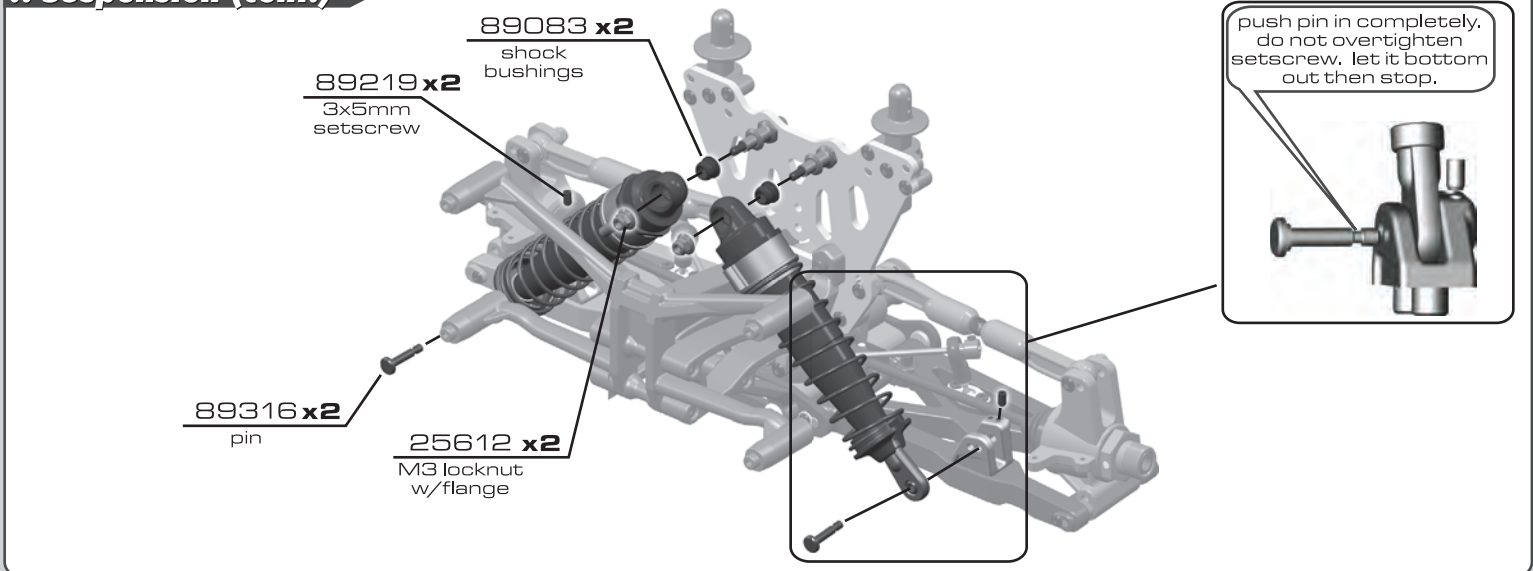

:: Suspension (cont.)

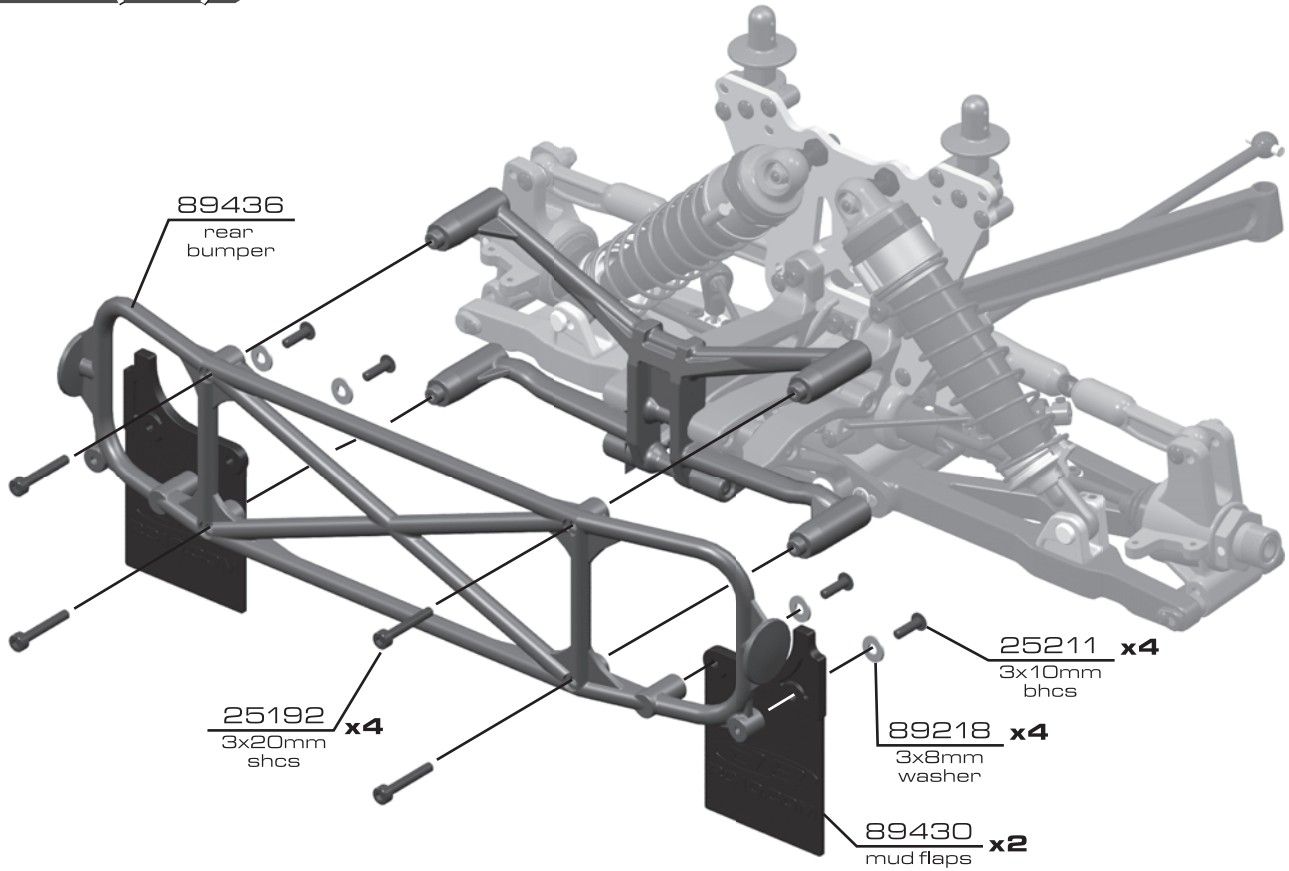

:: Chassis Assembly

BAG I

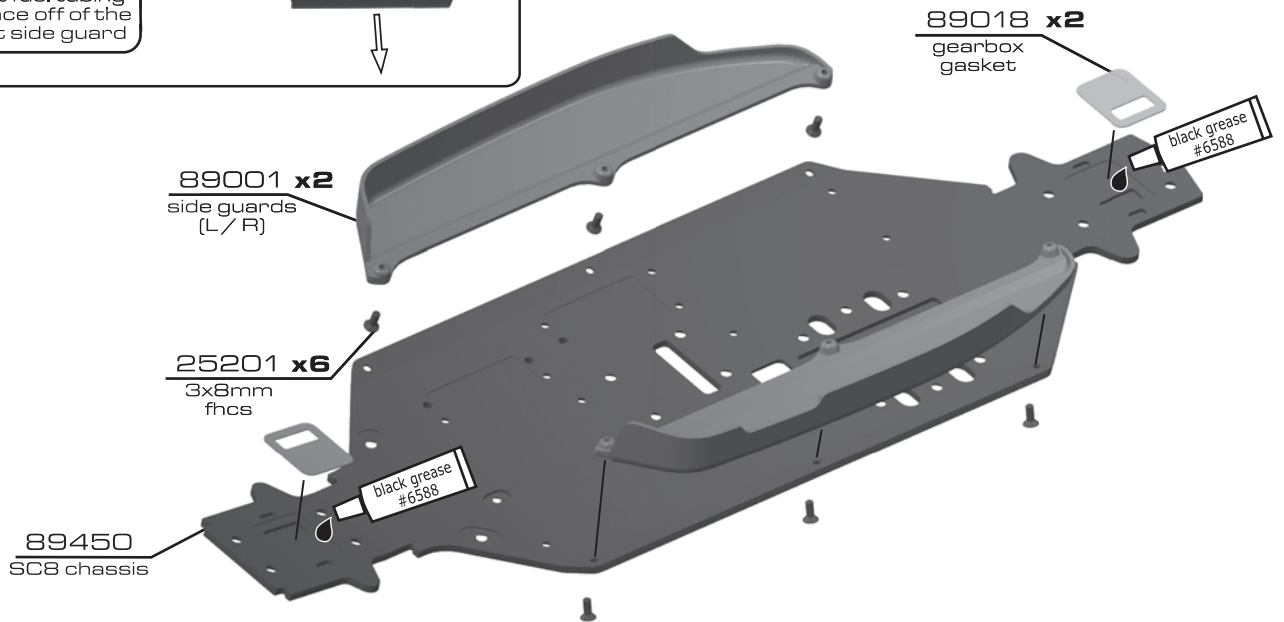
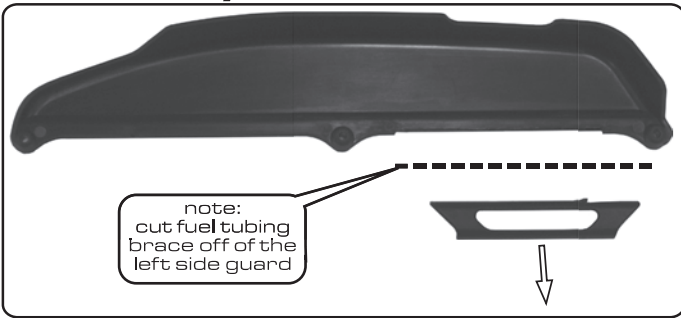

:: Chassis Assembly (cont.)

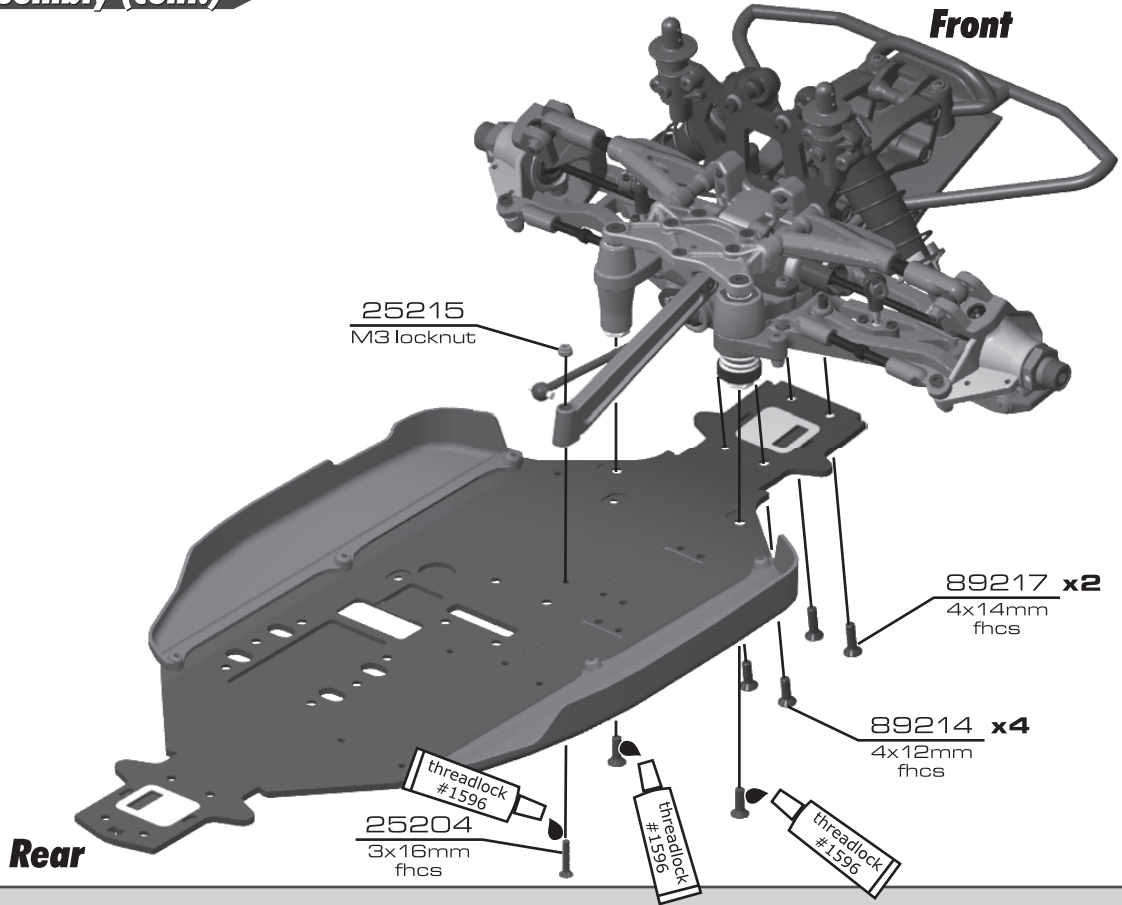

:: Chassis Assembly (cont.)

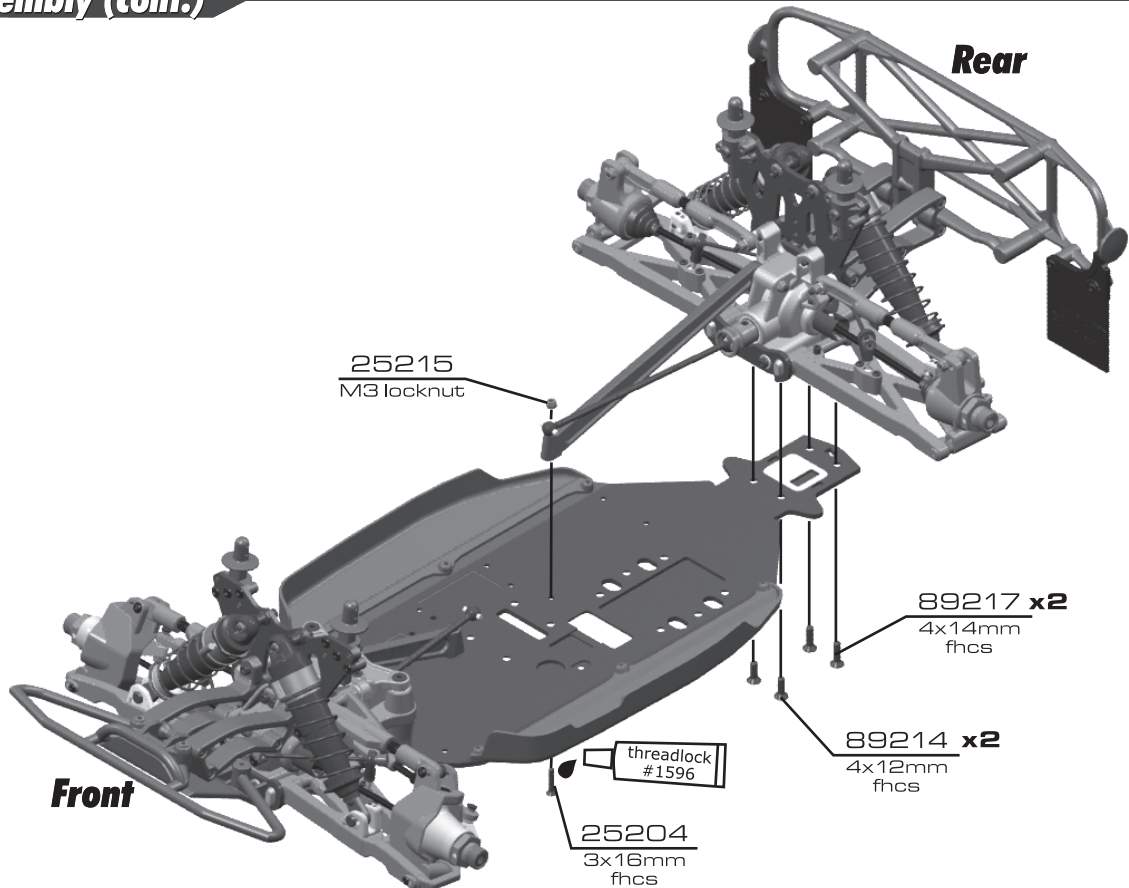

:: Center Bulkhead

BAG J

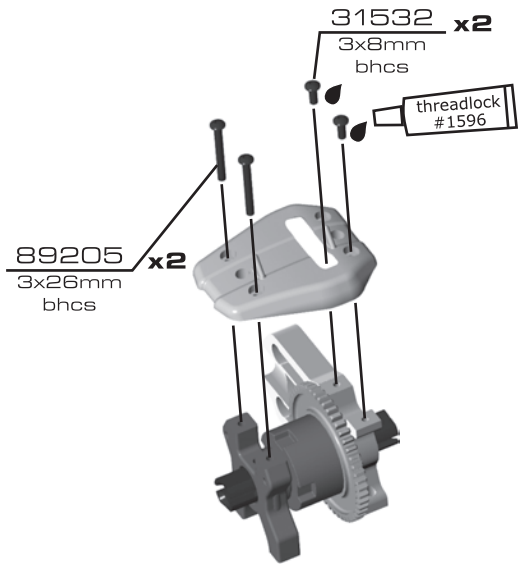
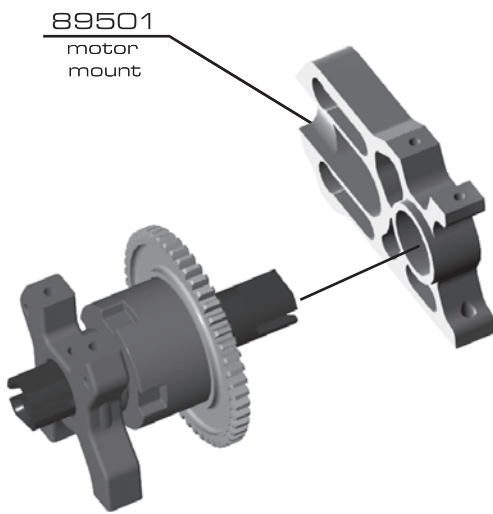
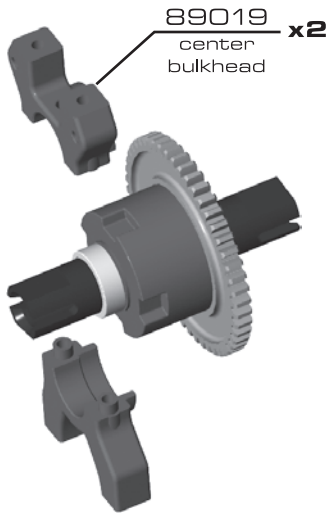

:: Center Bulkhead (cont.)



*Ensure dogbones are installed into diff outdrive cups.

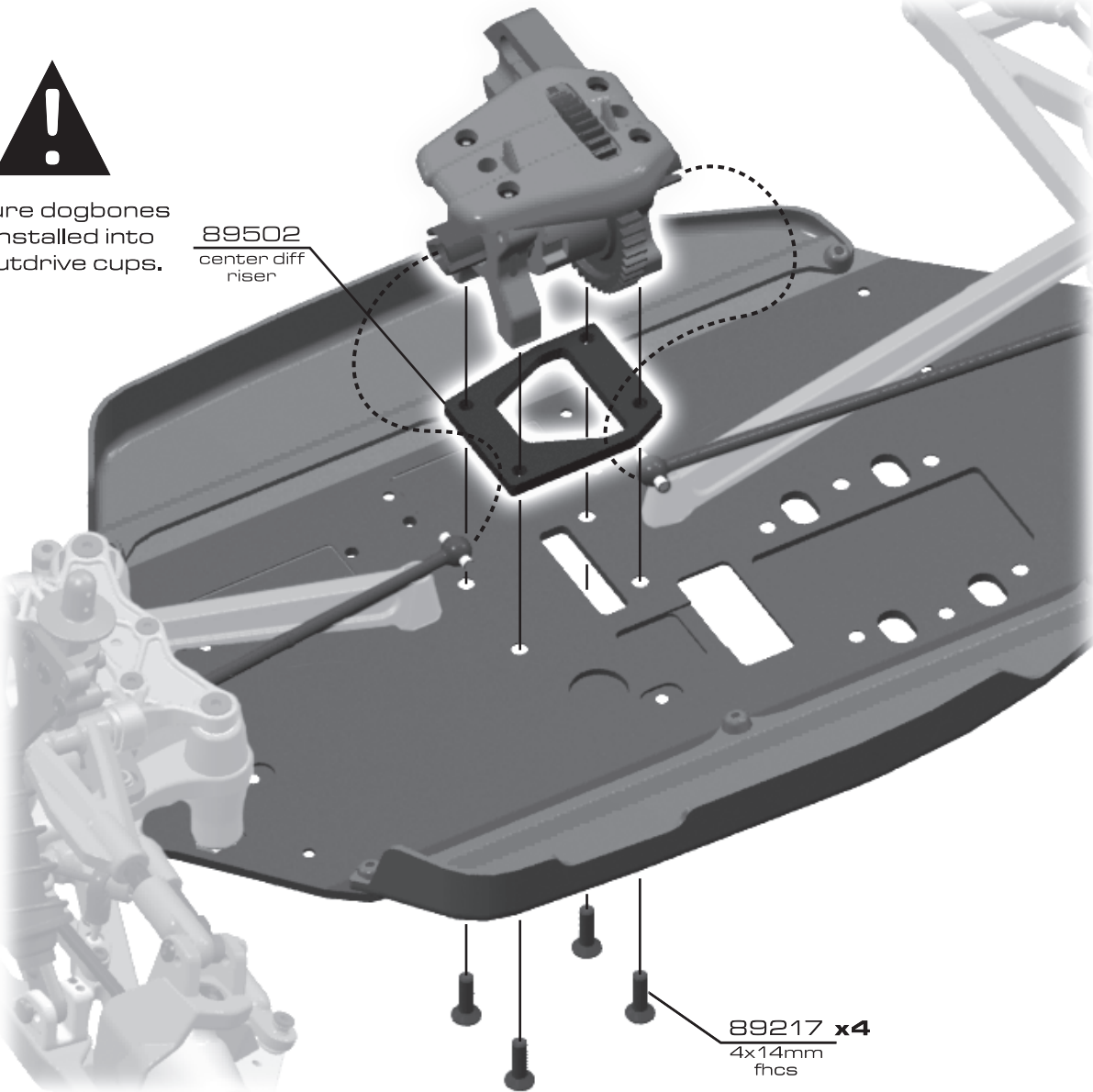

:: Battery / Radio Tray Build

BAG K

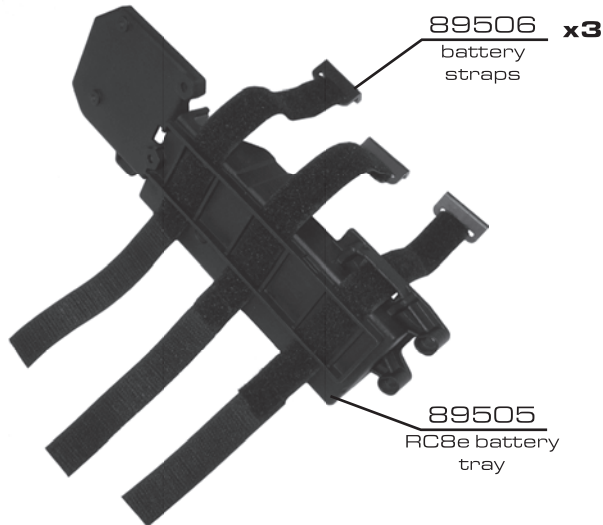

note:
speed control
not included.
attach with
servo tape.

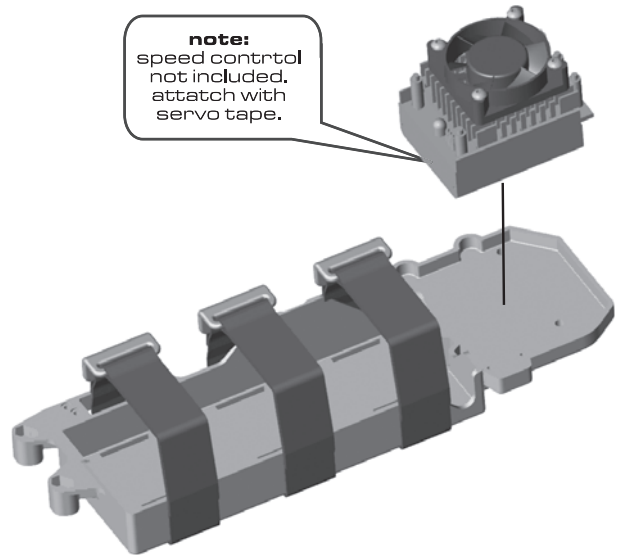

:: Battery / Radio Tray Build (cont.)

note:
route the speed
control receiver
wire through
this opening

note:
route the speed
control receiver
wire through
this opening

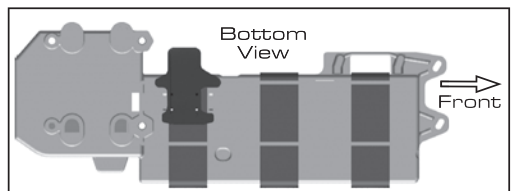
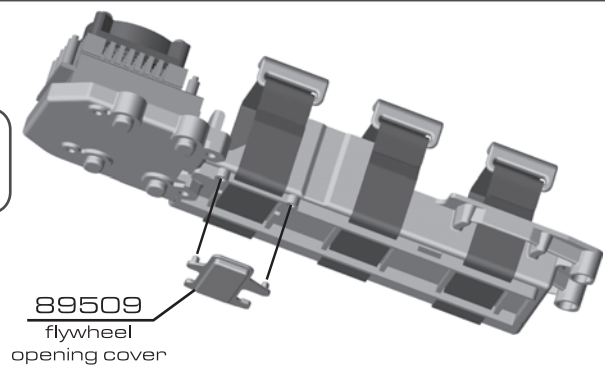
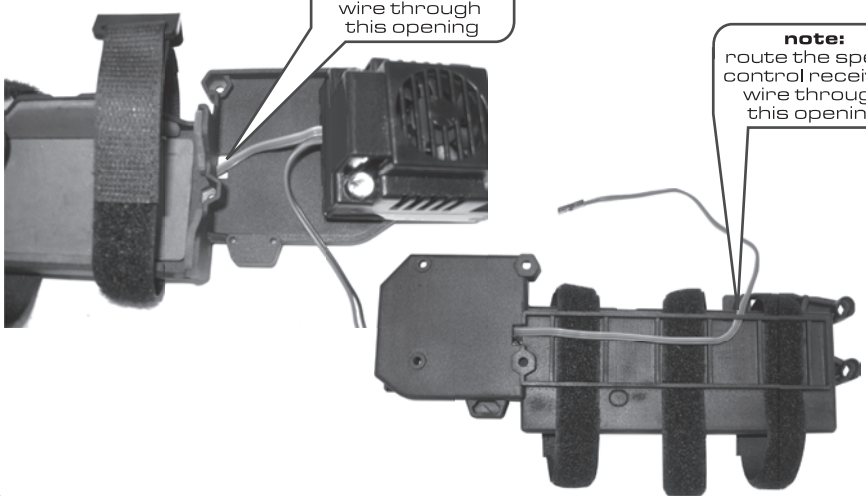

:: Battery / Radio Tray Build (cont.)

89509
battery tray
bridge

89222 x4
2.5x8mm
shcs

note:
the cutout on
the battery tray
bridge is facing
the battery tray!

note:
there are two
different positions
for the bridge screws
depending on what
vehicle you have.

89504
radio tray
(bottom)

note:
end battery
strap removed
for picture
clarity only!

SC8e

SC8e

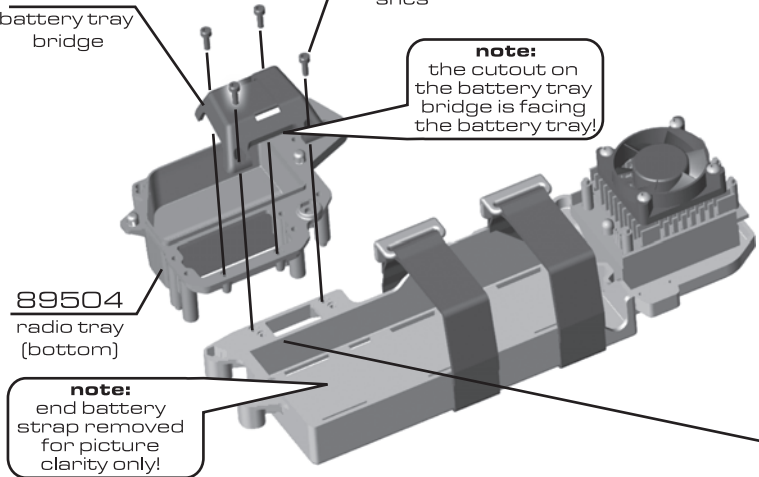
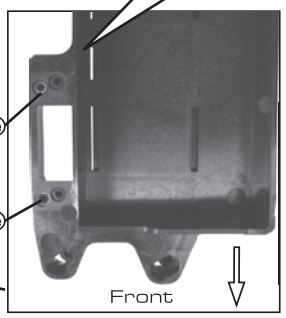

:: Battery / Radio Tray Build (cont.)



note:
route the speed control receiver wire up and over the bridge

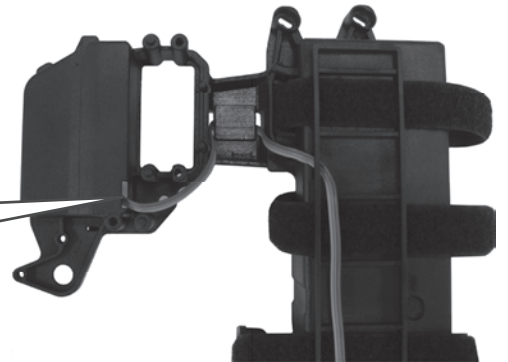

note:
route the speed control receiver wire through the radio box hole

:: Battery / Radio Tray Build (cont.)

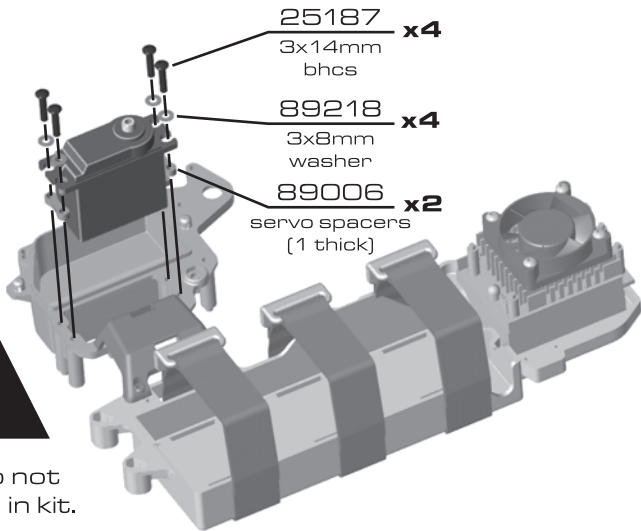

25187
3x14mm
bhcs x4

89218
3x8mm
washer x4

89006
servo spacers
(1 thick) x2



*Servo not included in kit.



note:
route the servo wire to the receiver through this opening

optional transponder mount location

:: Battery / Radio Tray Build (cont.)

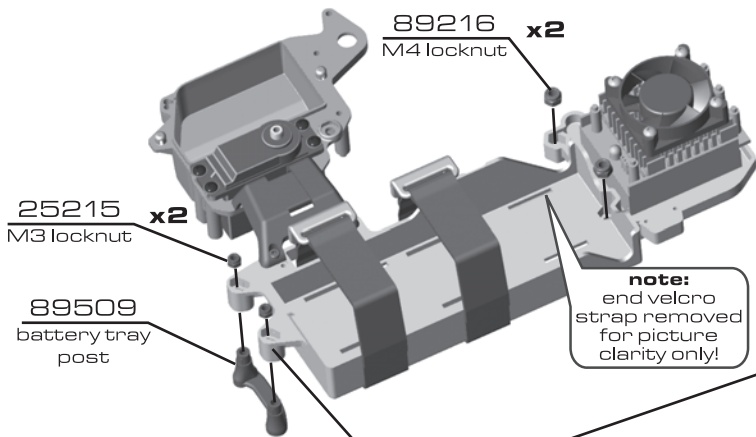

25215
M3 locknut x2

89509
battery tray post

89216
M4 locknut x2

note:
end velcro strap removed for picture clarity only!

note:
there are two different positions for the locknuts depending on what vehicle you have.

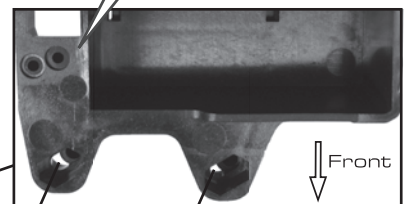

SC8e

SC8e

Front

:: Battery / Radio Tray Install



*screws and transponder not included in kit

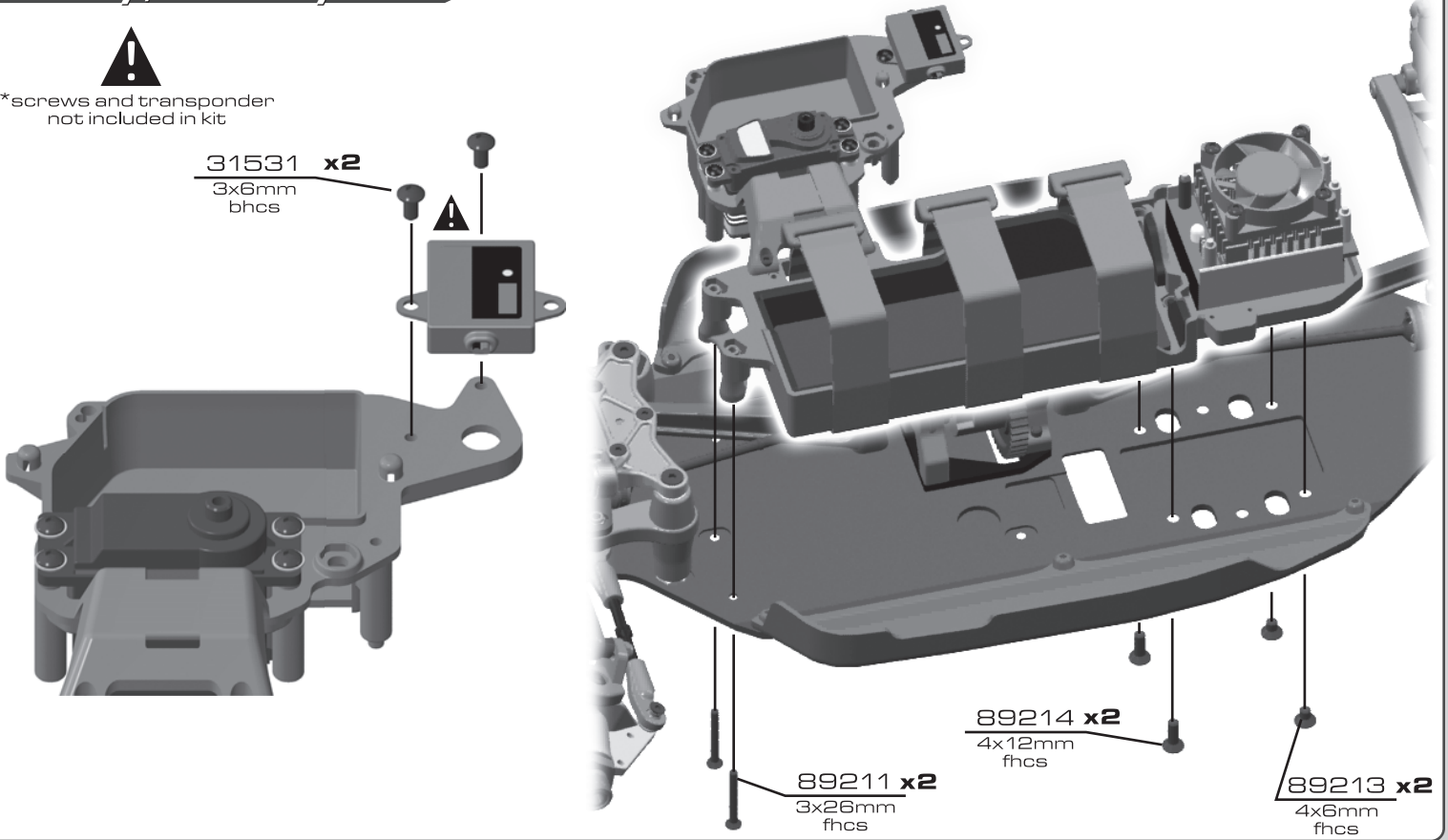

:: Battery / Radio Tray Install (cont.)

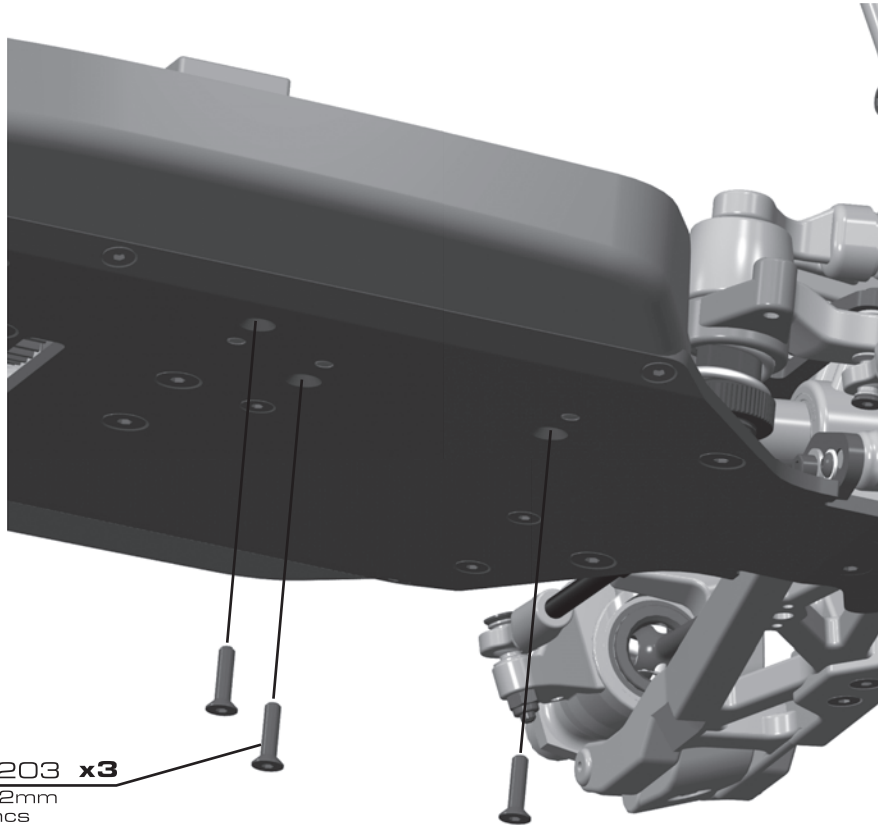

:: Battery / Radio Tray Install (cont.)

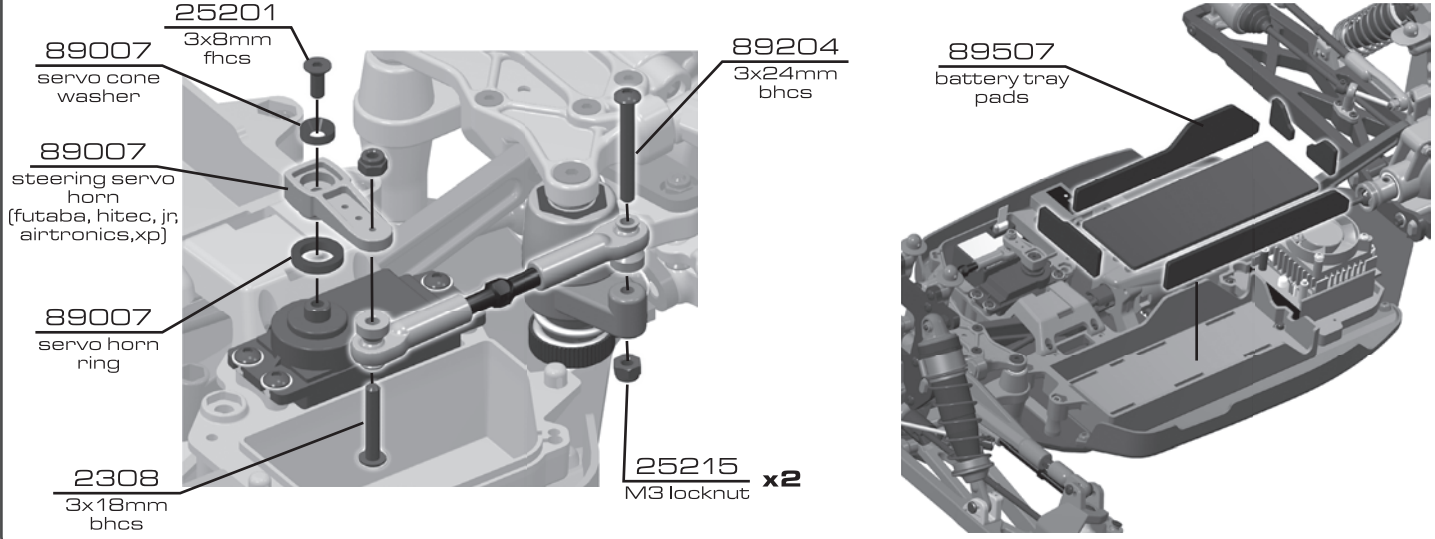

:: Battery / Radio Tray Install (cont.)

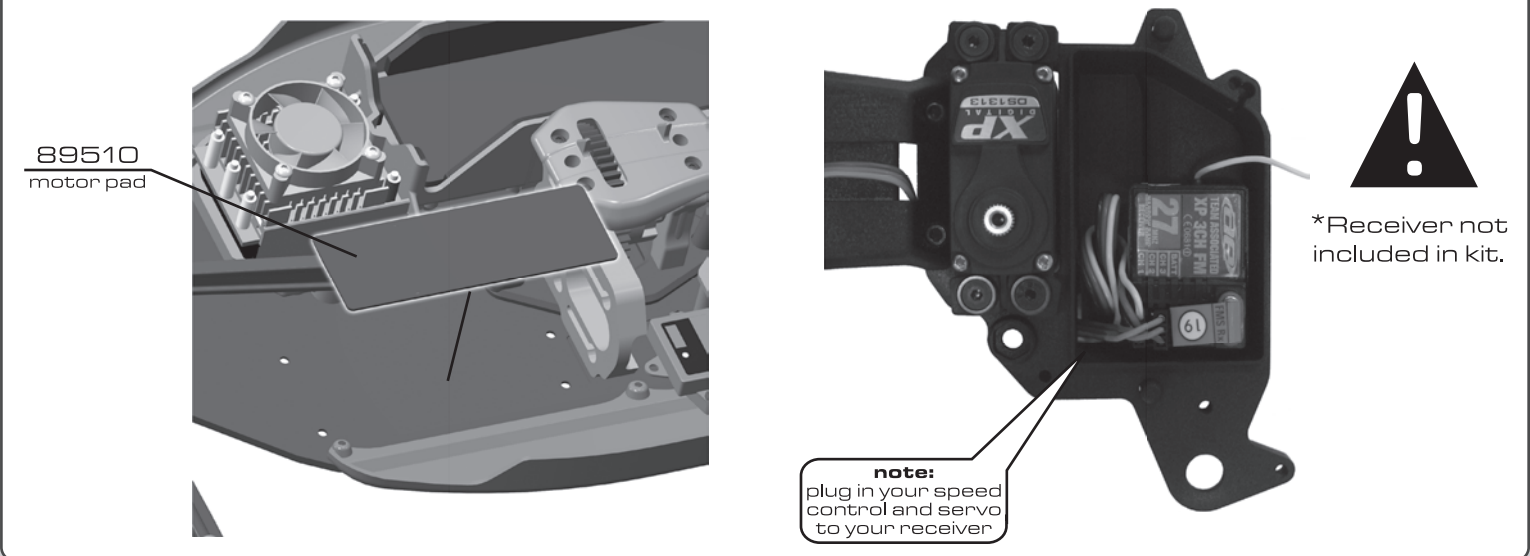

:: Battery / Radio Tray Install (cont.)

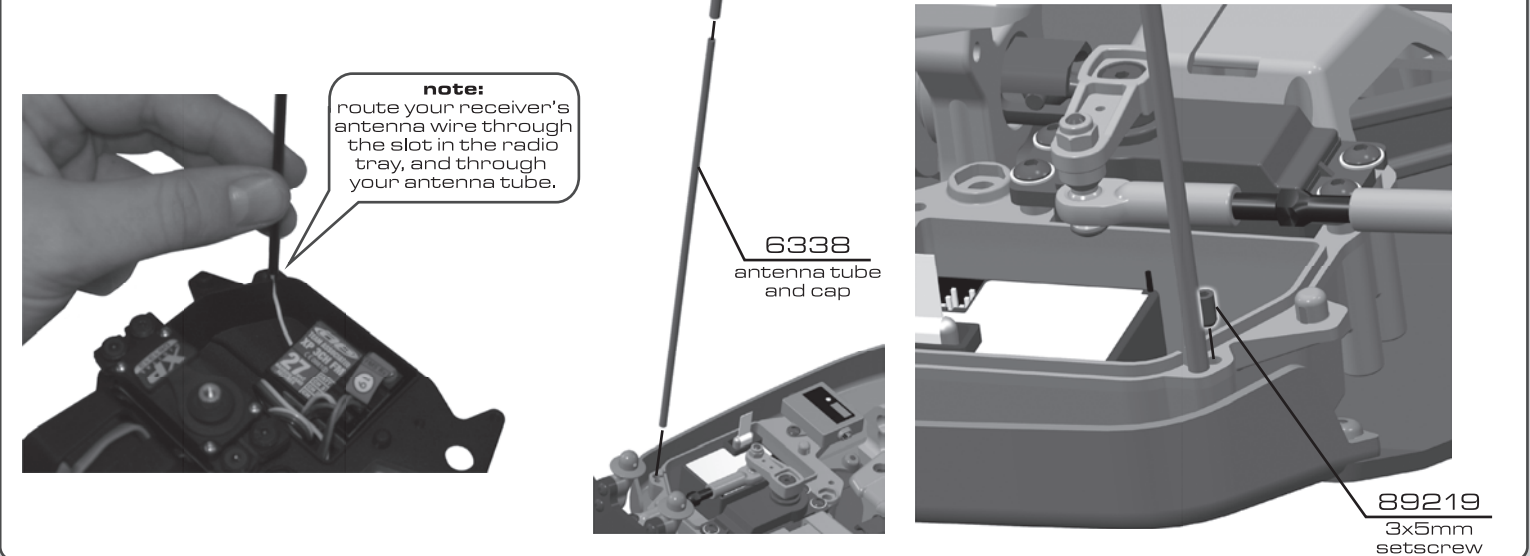

:: Battery / Radio Tray Install (cont.)

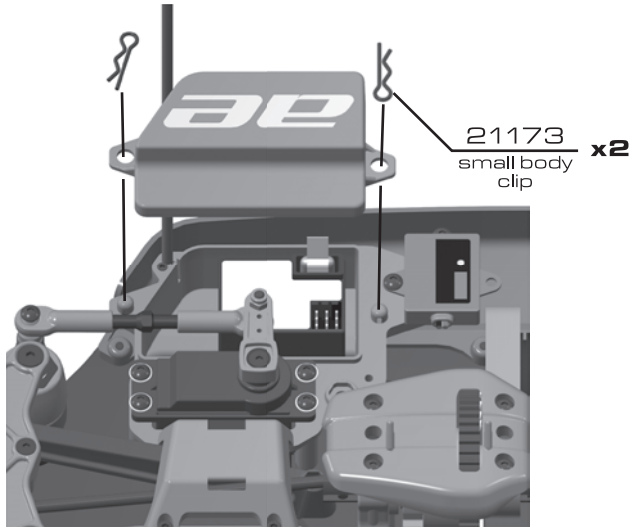

:: Electronics

BAGL

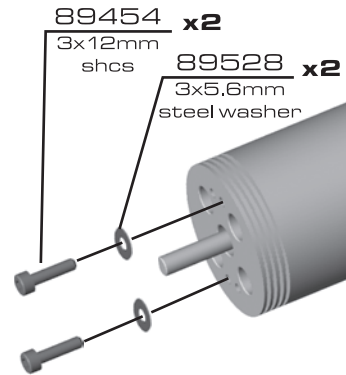

*Motor not included in kit.

:: Electronics (cont.)

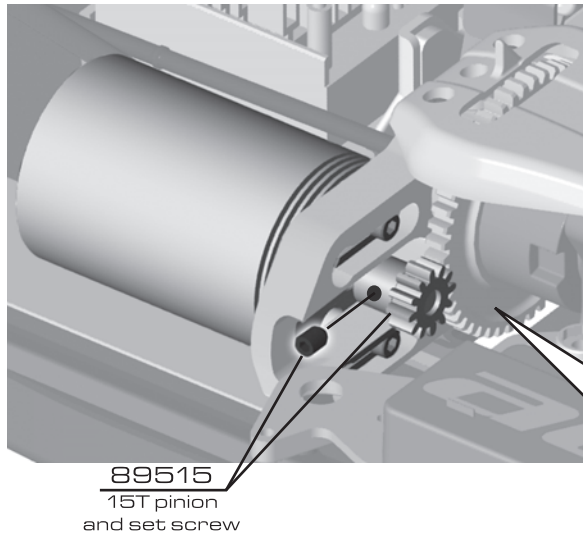
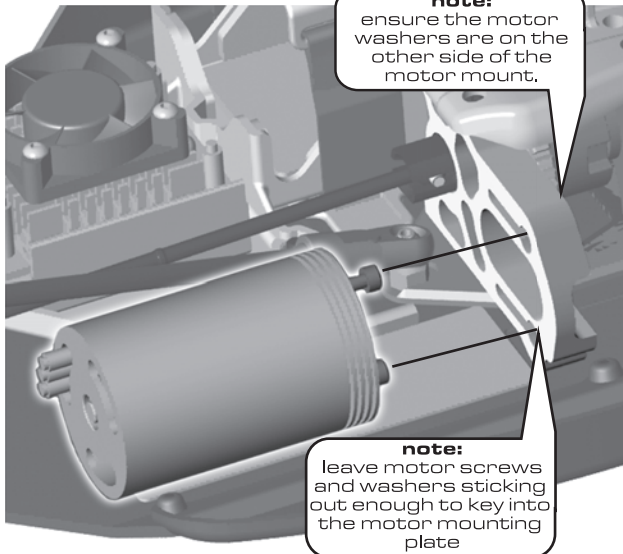

*Follow your motor manufacturer's recommendations for gearing.

note:
set gear mesh and tighten motor to the bulkhead with the included L wrench.

:: Electronics (cont.)

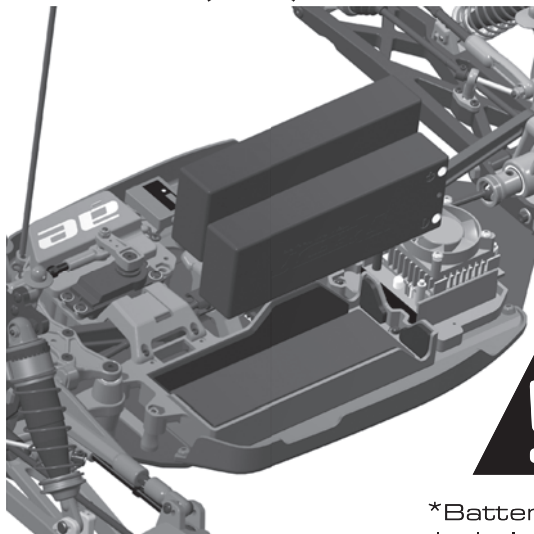

*Batteries not included in kit.

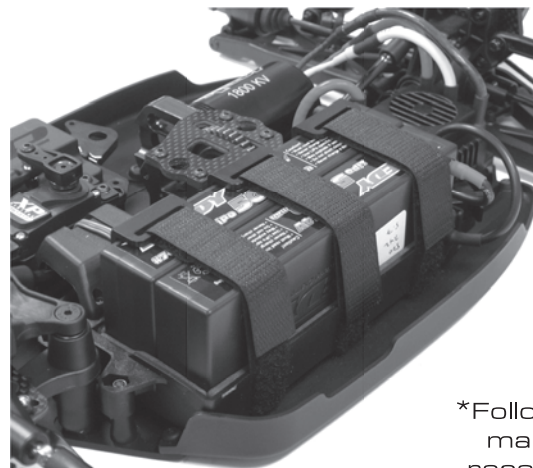

*Follow your battery manufacturer's recommendations for wiring setups.

:: Roll Cage Assembly

BAG M

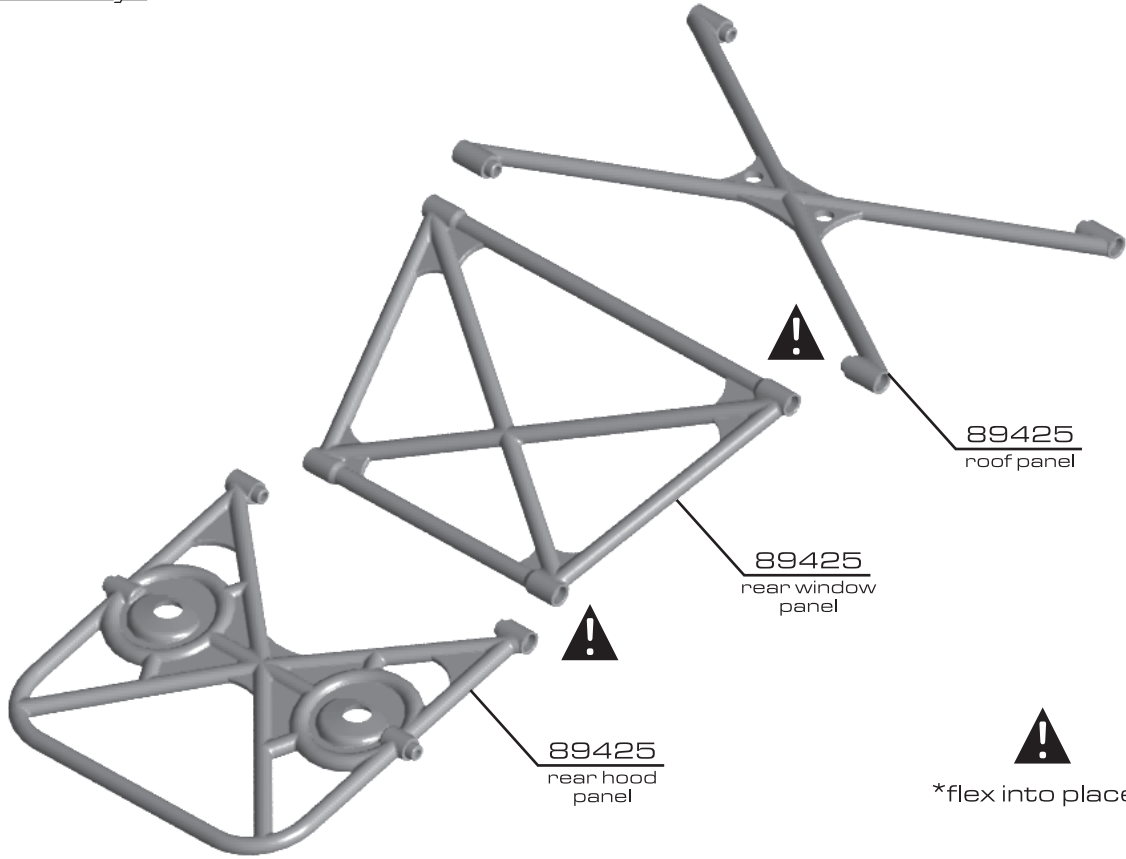

:: Roll Cage Assembly (cont.)

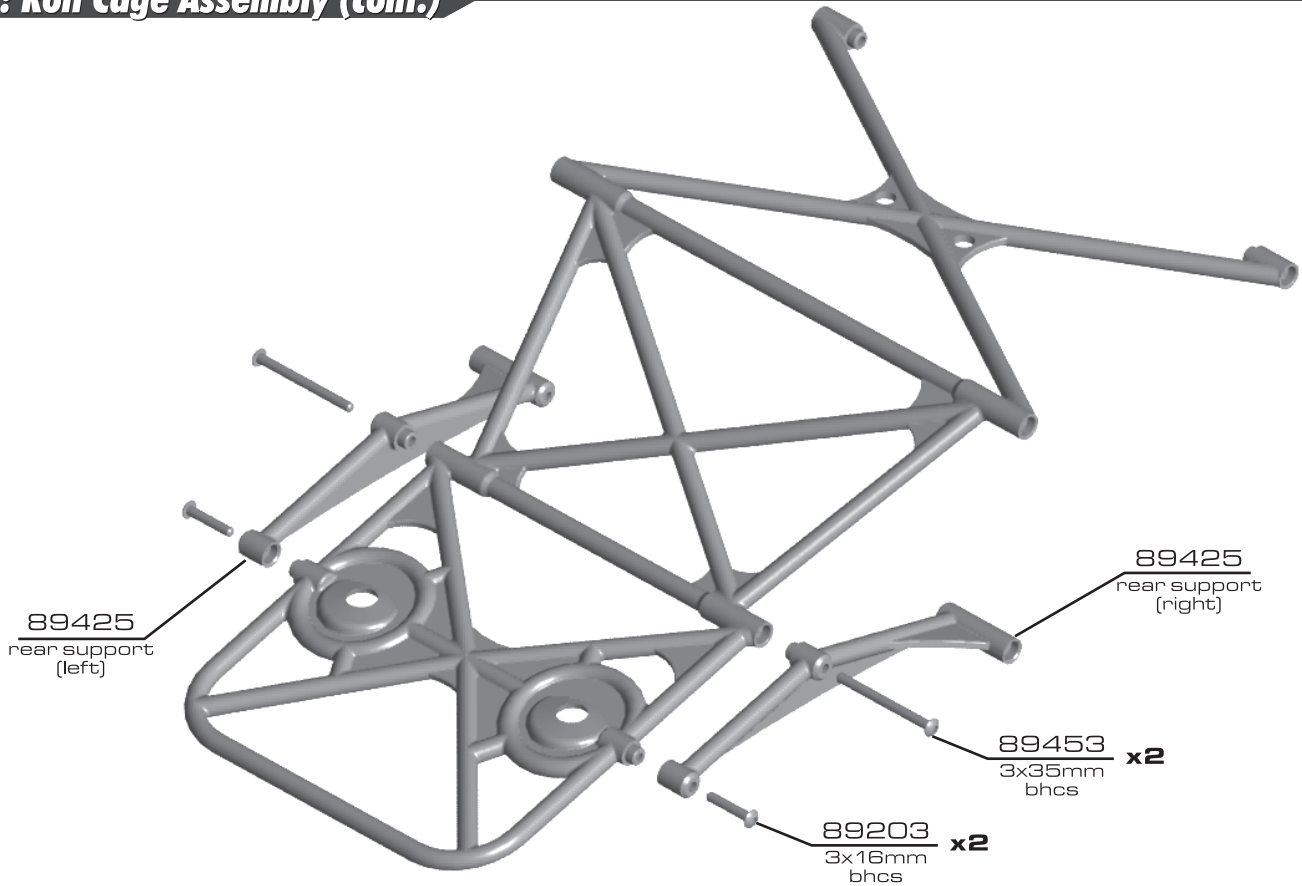

:: Roll Cage Assembly (cont.)

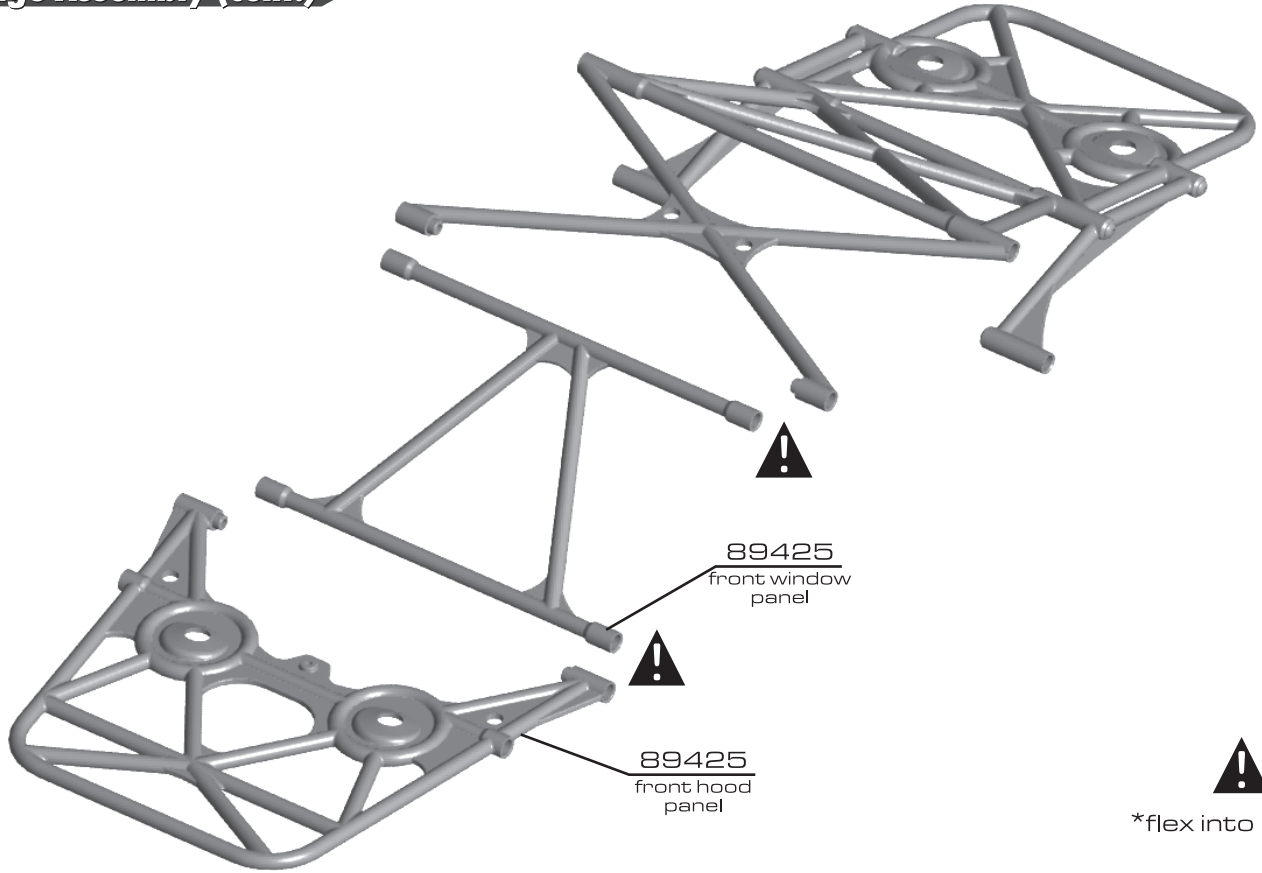

:: Roll Cage Assembly (cont.)

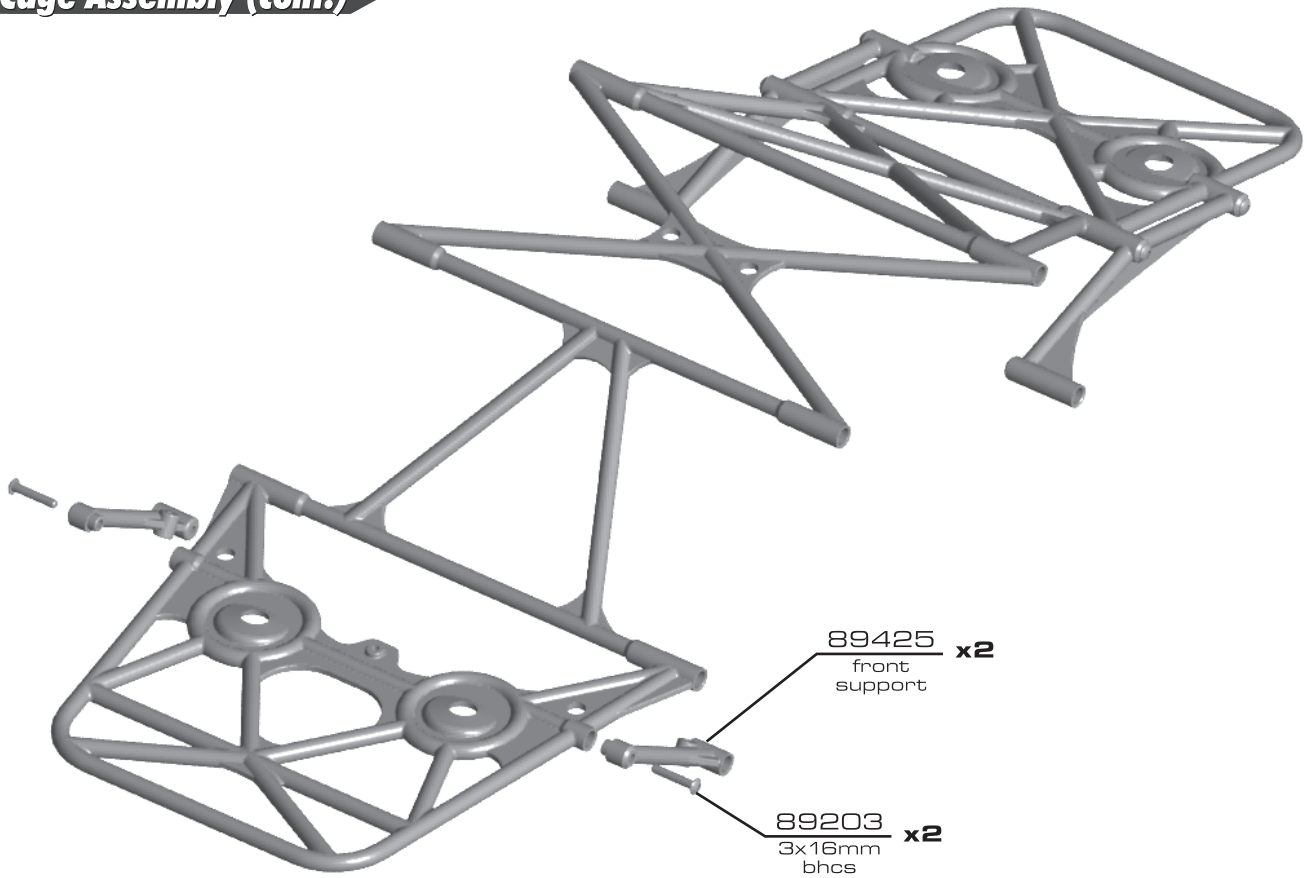

:: Roll Cage Assembly (cont.)

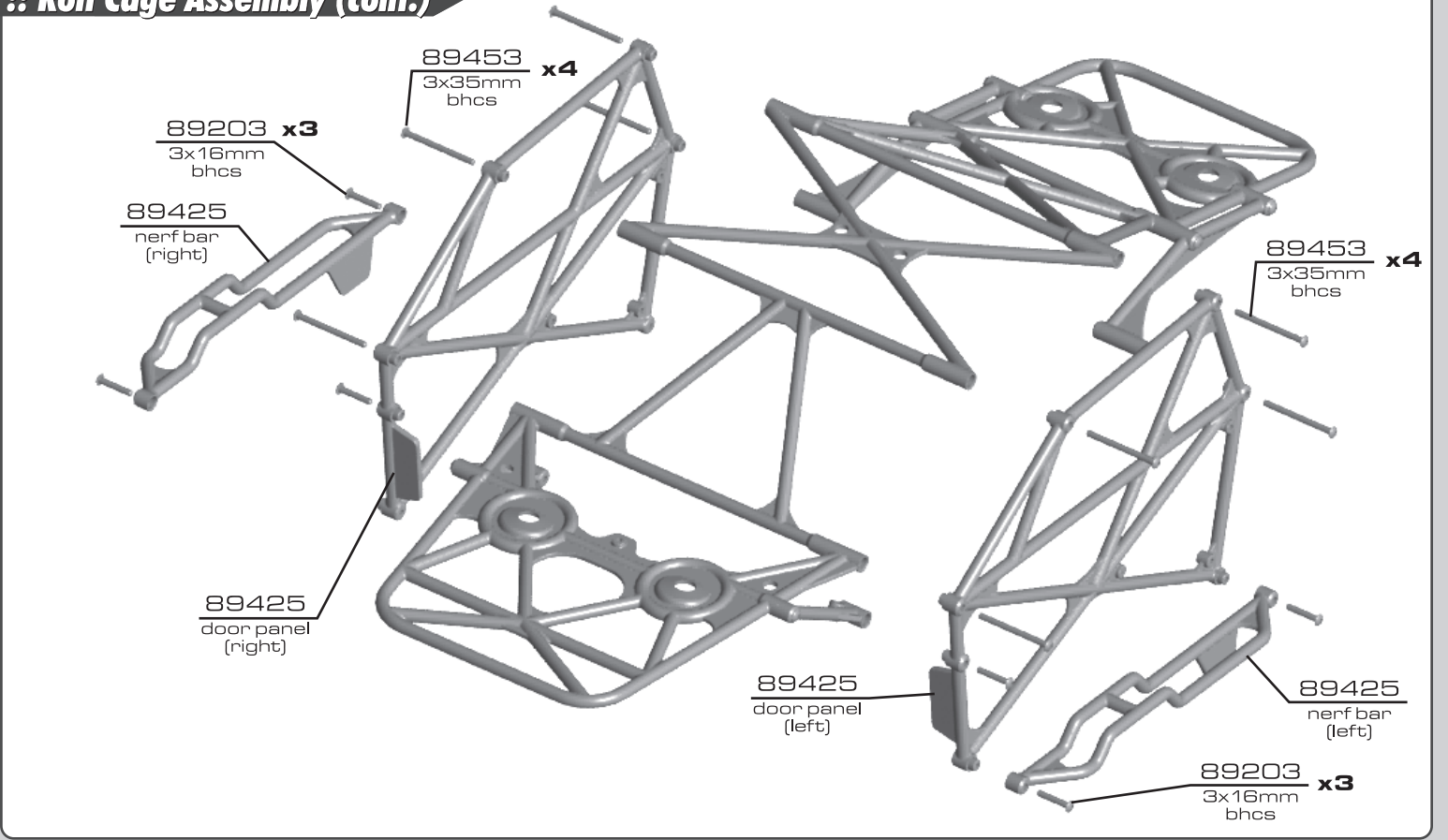

:: Roll Cage Assembly (cont.)

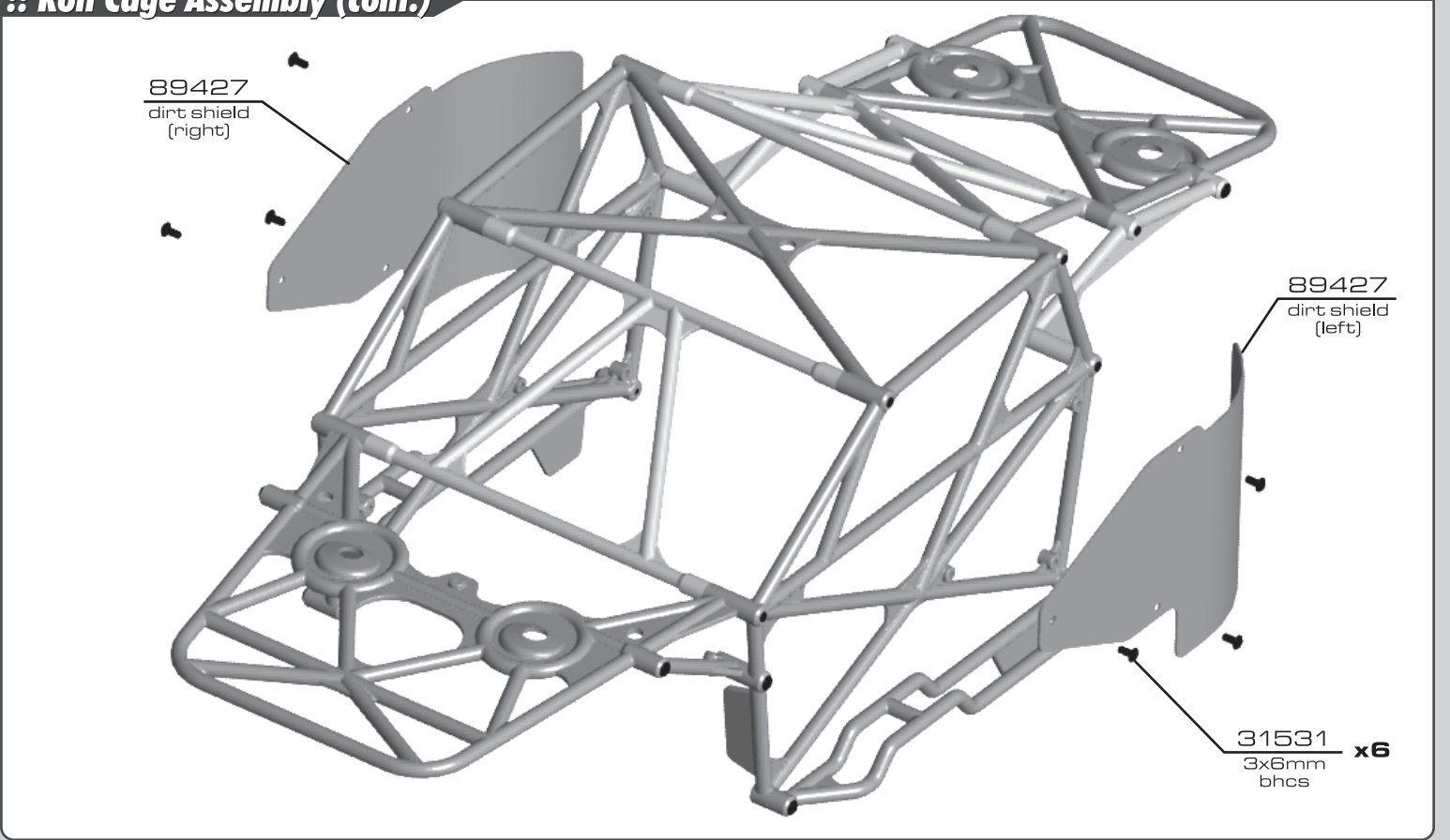

:: Roll Cage Assembly (cont.)

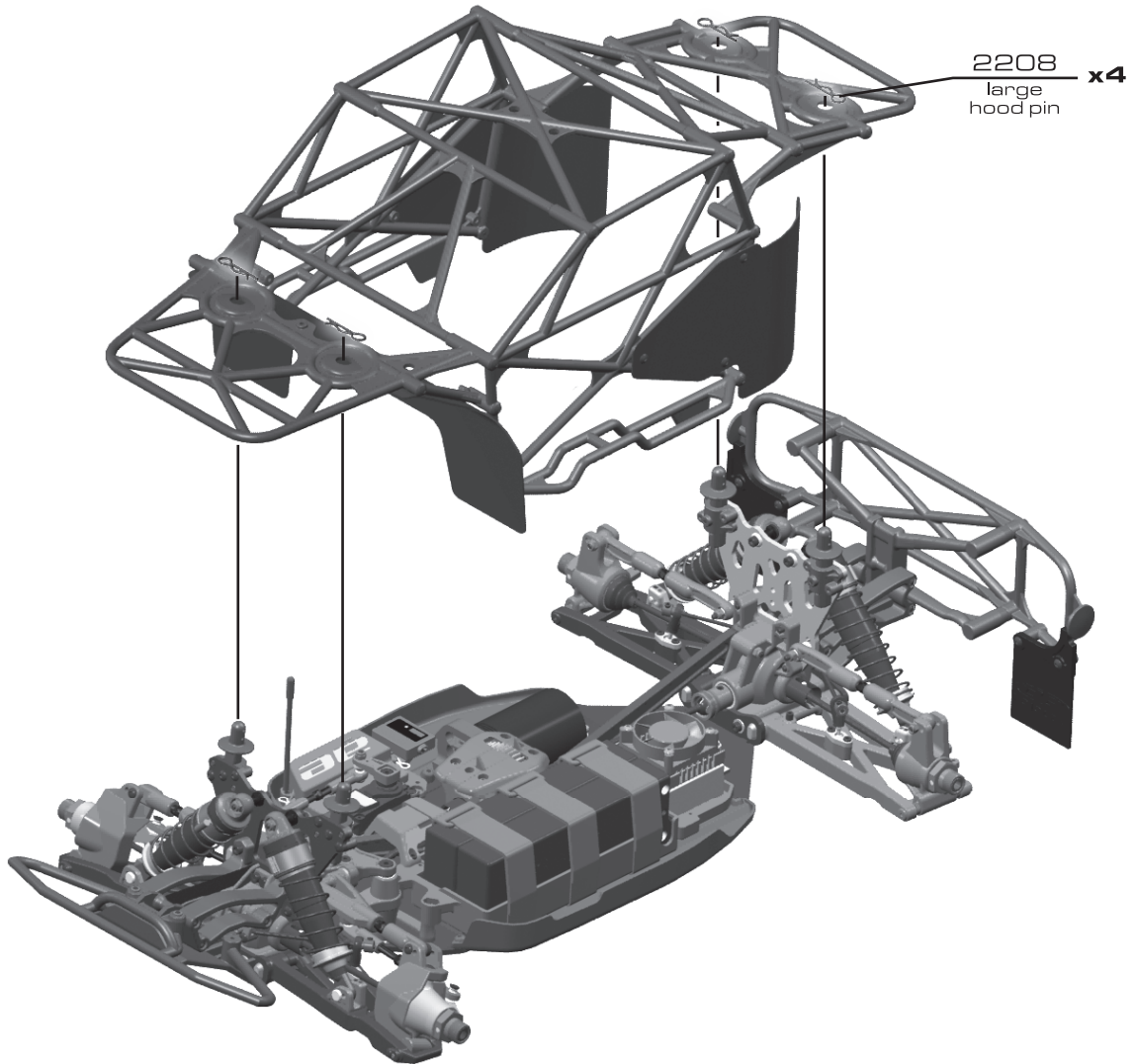
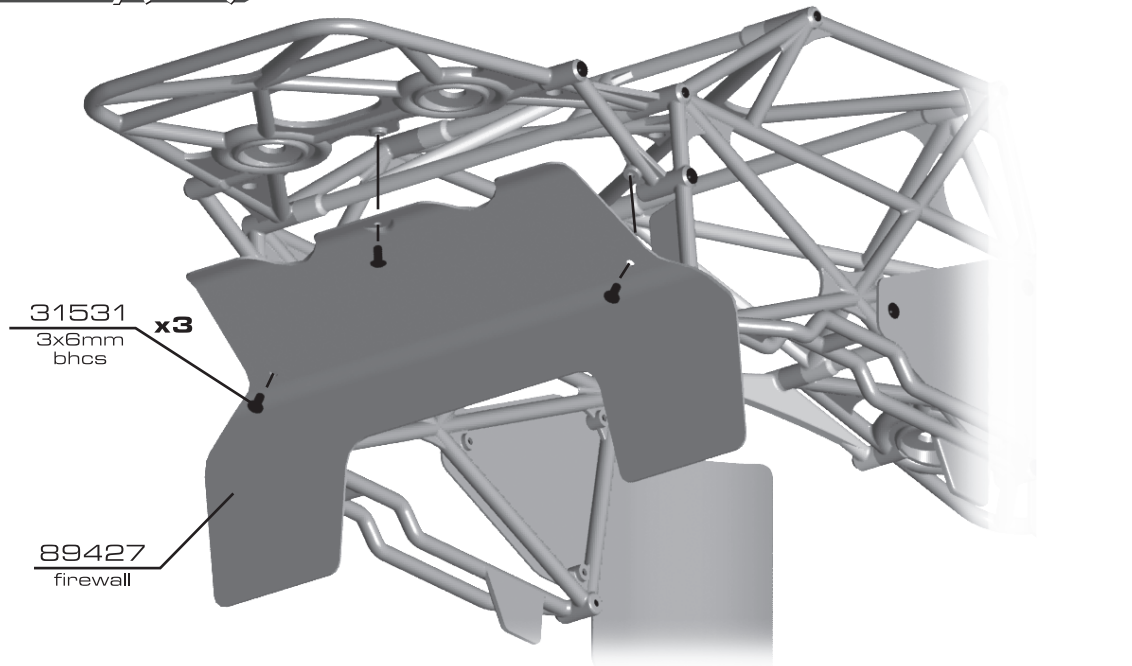

:: Wheel Assembly

89422
SC8 tire



89422
tire foam



89402
wheel
(kmc black)

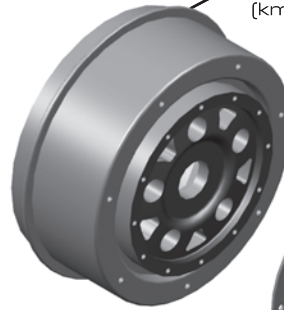

89416 x12
2x4mm
bhcs
(black)



89412
beadguard
(gold)



*Use tire adhesive (CA) to mount tires.

:: Wheel Assembly (cont.)

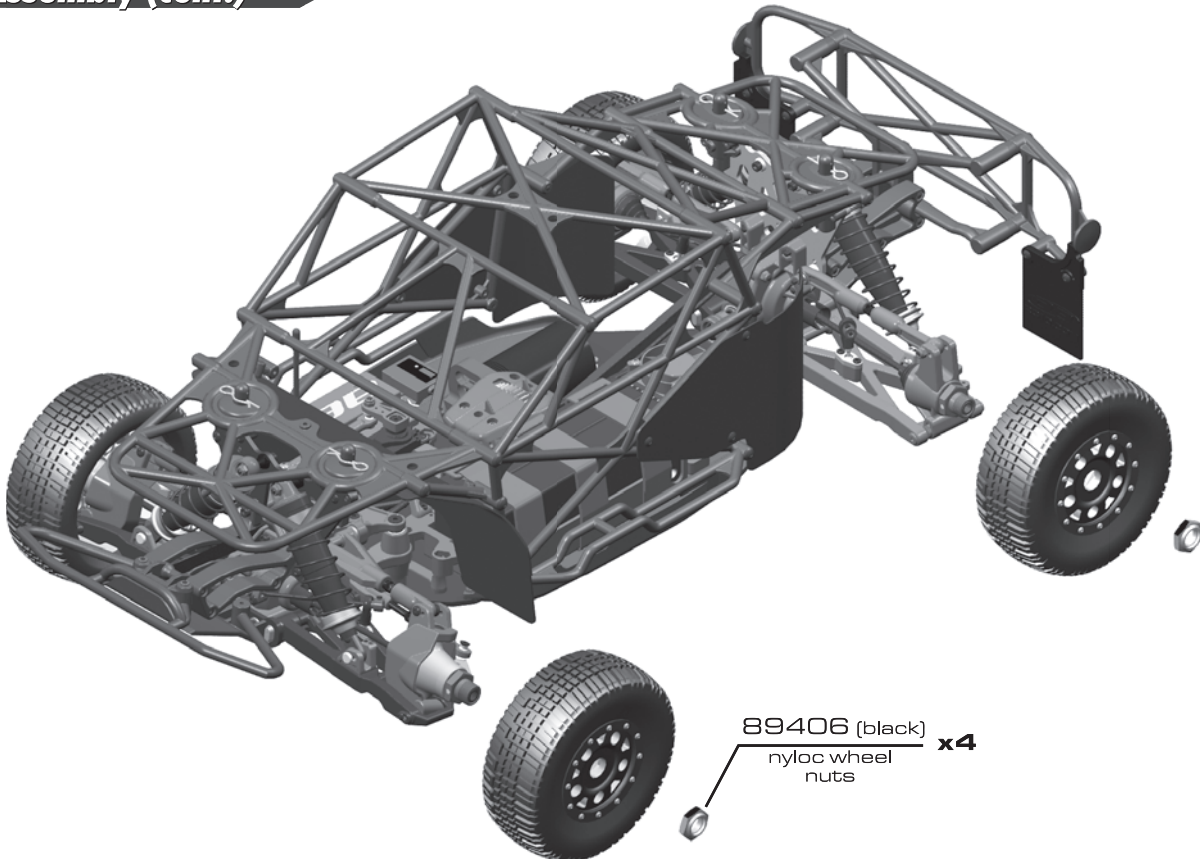

89406 (black) x4
nyloc wheel
nuts

:: Body Install

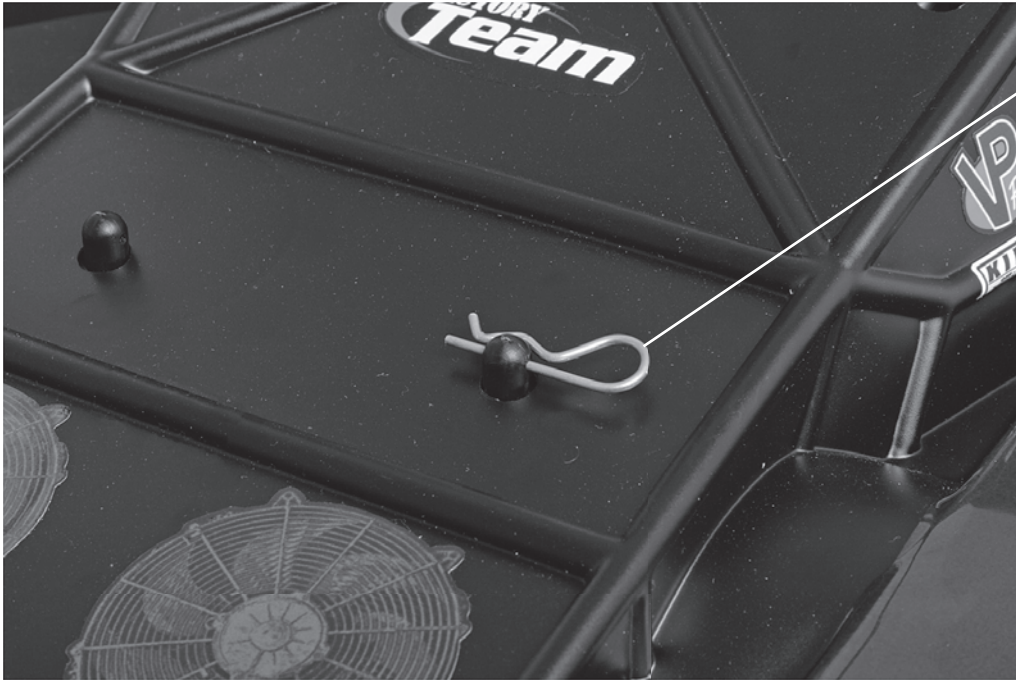

2208 x4
large
hood pin

:: Complete Truck

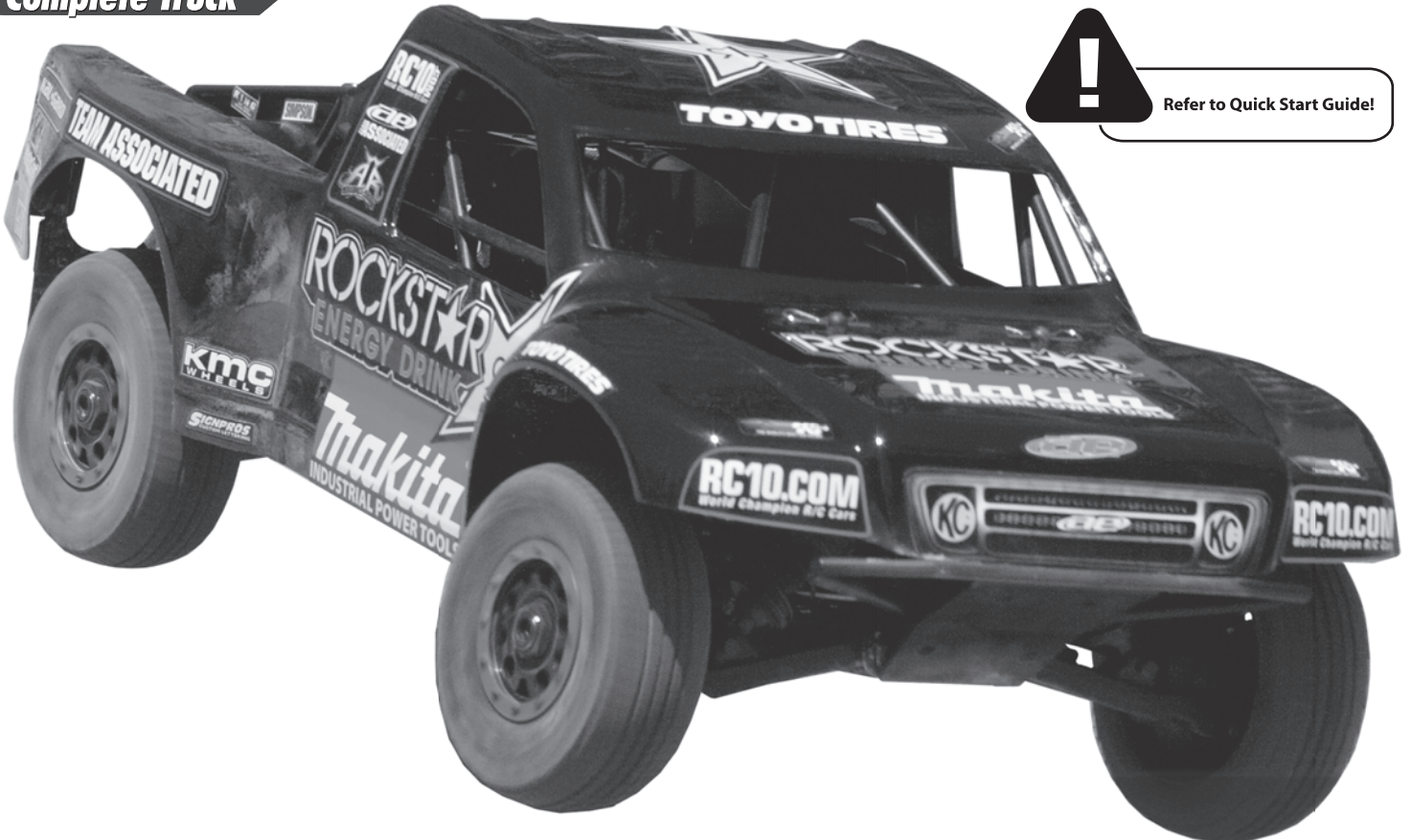

Refer to Quick Start Guide!

:: Chassis

Gearing:

Recommended Gearing: 15-46. This is a good starting point for most tracks. Follow your motor manufacturer's recommendations for gearing options.

*A higher kv motor, will require a smaller pinion gear

Gear Mesh:

To correctly set your gear mesh, follow the steps below:

1. Loosen the motor mount screws so you can slide your motor from side to side freely.
2. Slide the motor until the pinion gear comes in contact with the spur gear. Tighten the motor mount screws. Now "rock" the spur gear. There should be a little "free play" between the gears.
3. If you have a small amount of 'free-play', continue building your SC8e. If not, go back to Step 1. Be sure to check for "free-play" through a full rotation of the spur gear.

Differential Fluid:

Team Associated assembled the differentials with 5,000cst diff oil. You can also provide your own oil and try one of the optional setups.

Standard differential fluid setup: Front = 5,000cst; Center = 5,000cst; Rear = 5,000cst.

Optional diff setup 1 (high grip track): Front = 5,000cst; Center = 10,000cst; Rear = 5,000cst.

Center Differential:

Use the standard setup for most cases. Some racers will try thicker oil (7,000-10,000cst) when greater acceleration is needed. This is typically done on very smooth tracks since thicker fluid can reduce handling in bumpy conditions.

:: Front End:

Front Differential:

Use the standard setup for most cases. Try 7,000cst to 10,000cst to get less low speed steering and better acceleration out of turns.

Kickup Bushing:

Generally more kick-up will provide better handling in the bumps and have better straight line acceleration. Less kick-up will provide more all around steering and have a more aggressive feel.

Caster:

The standard caster block insert setup is for 16 degrees. The standard inboard kick-up is 9 degrees (2-dot up insert in A-plate). You can reduce the caster using 14 degree inserts (also move both upper cone washers in front of the ball joint) for smoother steering. Changing to 18 degree inserts (also move both upper washers behind the ball joint) will typically provide more steering on power but reduce handling in bumpy conditions.

Front Upper Pivot Insert:

The standard setup is to use 2-dot up in the tower and 2-dot up in the top plate. It is recommended to maintain a 1 dot gap (1 mm per dot) front to rear when using 2-dot up in the A-Plate. Reducing the A-Plate insert to 1-dot allows the use of same dot number insert in both tower and top plate. Going up to 3-dot up in the tower will give more turn in, but less steering on power/exit. Going down (1-dot, 2-dot down) will reduce turn in, but give more steering on exit.

Front Camber Link-Outer:

The standard short location will work the best for most tracks. Going to the long front link will give you more steering, but can make the car less predictable in bumps and exiting turns.

Front Camber Angle:

A good starting camber setting is -2 degrees. Positive camber, where the top of the tire is leaning out, is typically not recommended.

Front Toe-In:

Zero degree toe-in (tires pointing straight forward) is a good starting setting. You can increase turn in by adding 1-2 degrees of toe-out (front of tires point slightly out). Front toe - in is not a typical tuning adjustment used by the Team.

:: Front End (cont.):**Front Ride Height:**

The front ride height setting you should use most often is with 29mm of gap between the chassis bottom and the ground. Check the ride height with the FT Ride Height Gauge (# 1449) by lifting up the entire vehicle about 8-12 inches off the bench and drop it. After the suspension "settles" into place, then raise or lower the adjustment collars as necessary and recheck.

Front Arm Shock Location:

Inside on the arm will give a more responsive front end. Outside on the arm will be less responsive steering, but will be more predictable through bumps.

:: Rear End:

Rear Differential: Start with the standard setup. 5,000cst kit oil will rotate less in the turns and accelerate straight on power. The thinner oil (2,000 or 3,000cst) will give more low speed traction.

Anti-squat:

Anti-squat denotes the angle of the rear inner hinge pin relative to the ground. This setting is adjusted by changing the insert bushing in the C-Plate. The kit setting is 2 degrees (2-dot down) but you change to 1 degree (3-dot down). Typically less anti-squat lets the suspension work more over the bumps, but it will sacrifice the ability to square up on power.

Rear Camber Link Length & Vertical Adjustment:

You can change the length of the camber link on the hub or tower as well as adjust the vertical location on the tower. A longer link will give the feeling of the most grip, but it will not be as responsive to square up on throttle, and might get loose if driven hard. This can easily be corrected by running the shorter link on the hub, but it will sacrifice some forward grip.

Changing to a higher location on the tower will be a smaller adjustment than changing the length of the upper link. Going up on the tower location has a similar effect as a longer camber link, but not as drastic. For example, if you change to the short rear link on the hub and you need to gain more forward grip, try raising the link up on the tower.

Rear Hub Hinge Pin Height:

The upper hole gives more rear grip on turn in, and good forward traction, but it might have difficulty squaring up out of turns. The lower hinge pin hole in the hub will be more responsive on throttle, and give more side grip in the turns.

Rear Hub Spacing:

You have 3 options for rear hub spacing, FWD, MIDDLE, & BACK. The kit setting provides a good balance of rear traction and steering, and will be used most often. Moving the hubs FWD will give more rear traction for low grip tracks. You can use the hubs BACK on high grip tracks for more on-power steering. Also, you can replace the included shims to get intermediate settings.

Rear Camber:

A good starting camber setting is -2 degrees. Use the AE # 1719 camber gauge to set your camber. Adding a small amount of positive camber, where the top of the tire is leaning out, will tend to improve straight-line acceleration on loose tracks.

Rear Ride Height:

The rear ride height setting you should use most often is 29mm of gap between the chassis bottom and ground. Check the ride height with the FT Ride Height Gauge (# 1449) by lifting up the entire vehicle about 8-12 inches off the bench and drop it. After the suspension "settles" into place, then raise or lower the adjustment collars as necessary and recheck.

Rear Arm Shock Location:

Inside on the arm will give less entry steering, accelerates better straightline through bumps, but may lack side bite. Outside on the arm will be less grip, more steering, but will be more predictable when it breaks traction.

:: Droop Settings:

Droop Settings: (Truggy shown but applicable for all vehicles)

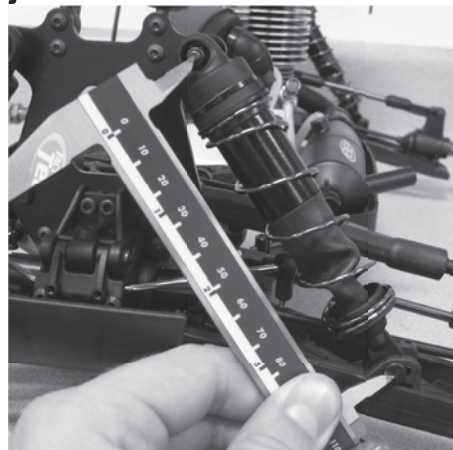

Step 1: With only the bottom of the shocks attached, the droop screws raised all the way, and the chassis above your working surface so the arms are at full extension, you should be able to easily slide the top of your shock over the standoff screw, while leaving the shock at full extension. If the mounting hole of the shock cap is above or below the standoff screw, adjust the droop screw accordingly. Repeat for all corners of your vehicle. Measure from the center of the standoff screw to the center of the shock riser button to get your FULL DROOP setting. The front shocks should be 109mm, while the rear shocks should be 127.5mm.

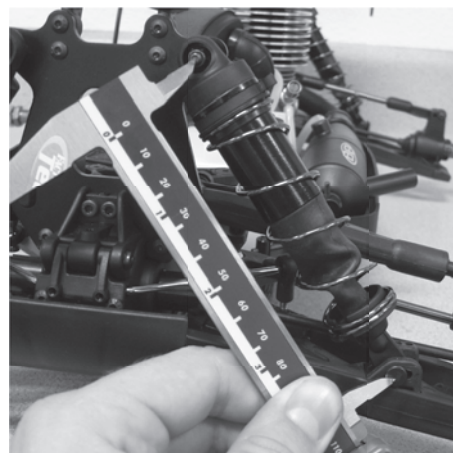

Step 2: Finish installing the shock to the standoff. Set your vehicle to your desired droop setting. To increase your droop turn the droop screw (from the top) counter-clockwise (loosen), turn the droop screw (from the top) clockwise (tighten) to decrease your droop. Remember, never back the screw out beyond full droop or you could risk damage to your vehicle.

Front Droop: Increasing front droop (loosen droop screws) will increase off-throttle steering. It also allows the front end to lift more, giving more rear grip and less front grip on-power. Remember to never loosen the screws beyond the FULL DROOP setting. Decreasing front droop (tighten droop screws) yields more on-power steering and quicker response at the expense of some stability in bumpy sections. It will also give less off-throttle steering.

Rear Droop: Increasing rear droop (loosen droop screws) will increase traction in bumpy sections, but will reduce high-speed stability. Remember to never loosen the screws beyond the FULL DROOP setting. Decreasing rear droop (tighten droop screws) will increase stability in high speed sections, but will reduce stability in bumpy sections.

Setup Sheets:

Most often the best way to get your car handling right is to go to our website www.rc10.com and click on the "racing" link, then the "Setups" link, then search for your vehicle. Our team of professional drivers help develop these setups at National events. Also, most drivers have a "base" setup that they use as a starting point for every event. Try running some of our base setups OR look for track conditions and tires that are similar to your local track and mimic that setup. Remember, each adjustment has a purpose, so copy everything from the setup sheet and then make adjustments based on the recommendations in here at <http://www.rc10.com/rc/tuning>.

:: Driver: Team Associated :: Date: _____
 :: Track: Standard SC8e Setup
 :: Event: _____

Setup Sheet for Team Associated's SC8e

Rev. 1

:: Front Suspension

anti-roll bar: 2.2 - black
 2.5 - silver
 2.8 - gold

front body mount hole:

hinge pin bushing # 1
 up down

camber: -2 °

caster: 16 °

toe: 0 °

ride height: 29mm

kickup bushing # 2
 up down

:: Rear Suspension

anti-roll bar: 2.2 - black
 2.5 - silver
 2.8 - gold

wheelbase: long
 medium
 short

rear body mount hole:

camber: -2 °

toe: 3 °

ride height: 29mm

anti-squat bushing # 2
 up down

:: Front Shocks

spring: (4.7 lb) Bronze piston: 1.3
 shock fluid: 40 wt length: 113mm
 shock cap: molded

:: Rear Shocks

spring: (4.0 lb) bronze piston: 1.3
 shock fluid: 40 wt length: 125mm
 shock cap: molded

:: Differentials

front fluid: 5,000cst center fluid: 5,000cst
 rear fluid: 5,000cst

:: Chassis Braces

pivot molded aluminum
 other: _____

:: Electronics

motor & wind: _____
 esc: _____ setting: _____
 batteries: _____
 radio: _____
 steering expo: _____
 brake e.p.a. : _____
 throttle expo: _____
 servo: _____
 initial brake: _____ drag brake: _____

:: Gearing

pinion gear: 15t
 spur gear: 46t

:: Tires

tire (F/R): _____ / _____
 compound (F/R): _____ / _____
 insert: _____ wheel: _____
 traction additive: _____

:: Race and Vehicle Comments

qualify: _____ main: _____ finish: _____ tq:
 comments: _____













:: Track Info

traction: high med. low
 surface: smooth bumpy
 blue groove soft dirt grass
 clay wet dusty
 other: _____

:: Hardware - 1:1















flat head (fhcs)

METRIC

	3x8mm (25201)
	3x10mm (25202)
	3x12mm (25203)
	3x14mm (89208)
	3x16mm (89224)
	3x18mm (25191)
	3x20mm (89210)
	3x22mm (89455)
	3x26mm (89211)
	4x6mm (89213)
	4x12mm (89214)
	4x14mm (89217)















cap head (shcs)

METRIC



	2.5x8mm (89222)
	3x8mm (89223)
	3x10mm (25620)
	3x12mm (89454)
	3x16mm (89224)
	3x18mm (25191)
	3x20mm (25192)
	3x22mm (89474)
	3x24mm (89225)
	3x26mm (89226)
	3x28mm (89227)
	3x40mm (89228)
	3x45mm (89279)
	3x50mm (89452)

button head (bhcs)





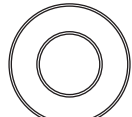
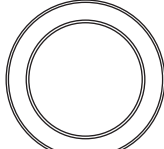

METRIC

	2x4mm black (89416) silver (89417)
	2.5x3mm (89201)
	2.5x6mm (31520)
	3x6mm (31531)
	3x10mm (25211)
	3x12mm (89202)
	3x14mm (25187)
	3x16mm (89203)
	3x18mm (2308)
	3x20mm (25188)
	3x24mm (89204)
	3x26mm (89205)
	3x35mm (89453)
	4x10mm (89206)
	4x12mm (89207)

ball bearings



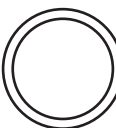

	steering bearing (89161)
	5x10mm (25237)
	6x10mm (31404)
	8x16mm (25236)
	15x21mm (89162)

shims & washers



	aluminum balltud washer (9630)
	3x5.6mm steel washer (89528)
	2.5mm washer (89278)
	blue countersunk washer (89229)
	silver cone washer (89230)
	3x8mm thin washer (89218)
	diff washer (89120)
	diff shim (89117)

setscrews

METRIC

	3x3mm (25225)
	3x5mm (89219)
	4x3mm (25223)
	4x12mm (89220)
	5x4mm (89221)

nuts (lock/plain)

	piston locknut (89215)
	m3 locknut (25215)
	flanged m3 locknut (25612)
	m4 locknut (89216)

Setup Sheet for Team Associated's SC8e

Rev. 1

:: Front Suspension

- anti-roll bar:
- 2.2 - black
 - 2.5 - silver
 - 2.8 - gold

front body mount hole



hinge pin bushing

- up down

camber: _____

caster: _____

toe: _____

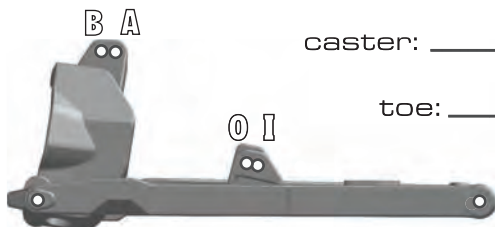

ride height: _____

kickup bushing

- up down

:: Rear Suspension

- anti-roll bar:
- 2.2 - black
 - 2.5 - silver
 - 2.8 - gold

wheelbase:

- long
- medium
- short

rear body mount hole



camber: _____

toe: _____

hub:
upper
lower

ride height: _____

anti-squat bushing

- up down

:: Front Shocks

spring: _____ piston: _____
 shock fluid: _____ length: _____
 shock cap: _____

:: Rear Shocks

spring: _____ piston: _____
 shock fluid: _____ length: _____
 shock cap: _____

:: Differentials

front fluid: _____ center fluid: _____
 rear fluid: _____

:: Chassis Braces

- pivot molded aluminum

other: _____

:: Electronics

motor & wind: _____
 esc: _____ setting: _____
 batteries: _____
 radio: _____
 steering expo: _____
 brake e.p.a. : _____
 throttle expo: _____
 servo: _____
 initial brake: _____ drag brake: _____

:: Gearing

pinion gear: _____
 spur gear: _____

:: Tires

tire (F/R): _____ / _____
 compound (F/R): _____ / _____
 insert: _____ wheel: _____
 traction additive: _____

:: Race and Vehicle Comments

qualify: _____ main: _____ finish: _____ tq:
 comments: _____

:: Track Info

traction: high med. low
 surface: smooth bumpy
 blue groove soft dirt grass
 clay wet dusty
 other: _____
