

# ASSOCIATED 1:10 SCALE ELECTRIC TRUCK MANUAL



## INSTRUCTION MANUAL FOR THE TEAM ASSOCIATED RC10T4 TRUCK



- >> New Longer MIP CVD dog bones and axles.
- >> Lower motor mounting position.
- >> Kimbrough Spur Gear.
- >> Racing compound front and rear tires.
- >> Plenty of chassis room to hold most electronics.
- >> All-new molded composite low-CG chassis.
- >> Adjustable battery position.
- >> New design battery hold-down strap.
- >> Rugged steel turnbuckles.
- >> Fully adjustable caster, camber, and toe-in.
- >> Angled bellcrank "co-planar" steering.
- >> Built-in servo saver.
- >> Vertical ball end adjustment, front & rear.

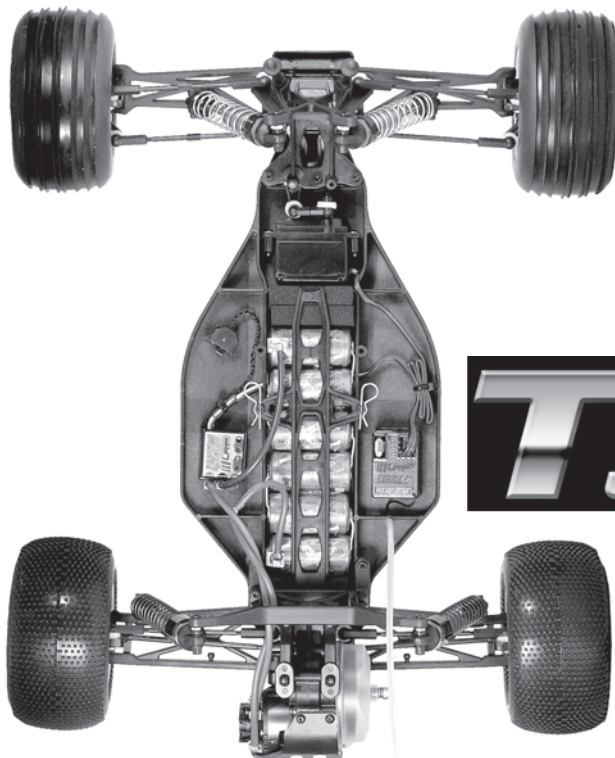

## T4 Truck Kit #7020

Hard anodized shock bodies.  
CVD rear axles.  
Unpainted body.

**Also includes:**  
Bearing Stealth Transmission.  
Racing compound tires



## TOOLS

### KIT TOOLS SUPPLIED

- 1 Allen wrenches #6950 (.050", 1/16", 3/32", 5/64")
- 2 Molded tools #6956
- 3 Camber gauge #1719
- 4 Shock building tool #6429

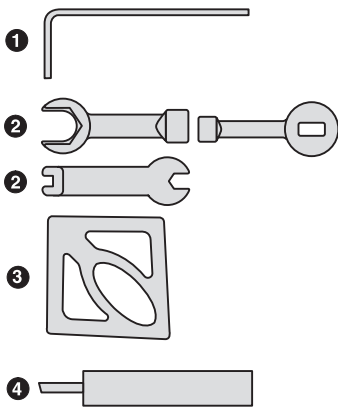

### HELPFUL ITEMS (NOT REQUIRED)

- 1 Allen drivers (straight Allen wrenches with hex shaped handles) such as the following made by Associated:
  - #6957 .050" driver
  - #6958 1/16" driver
  - #6959 5/64" driver
  - #6960 3/32" driver
  - #6961 2.5mm driver
- 2 Vernier calipers
- 3 Body Scissors (#1737)
- 4 Green Slime shock lube (#1105)
- 5 Nut drivers (screwdriver-handled hex socket tools)
  - 3/16" nut driver
  - 1/4" nut driver
  - 11/32" nut driver

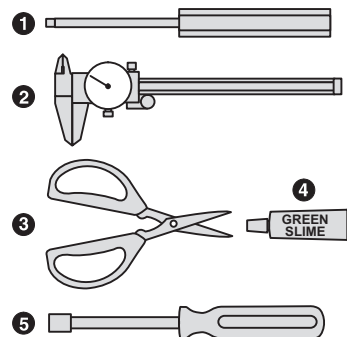

### EXTRA TOOLS NEEDED

- 1 Phillips screwdriver
- 2 Needle-nose pliers
- 3 Soldering iron (40-50 watts) and a small amount of Rosin core solder. Pencil-type soldering iron is better than the gun type.
- DANGER! Tip will be HOT!**
- 4 Thread locking compound (#1596 Locking Adhesive or equivalent)
- 5 Super glue (cyanoacrylic glue or #1597 Tire Adhesive).
- 6 Hobby knife **WARNING! This knife cuts plastic and fingers with equal ease, so be careful.**
- 7 Precision ruler

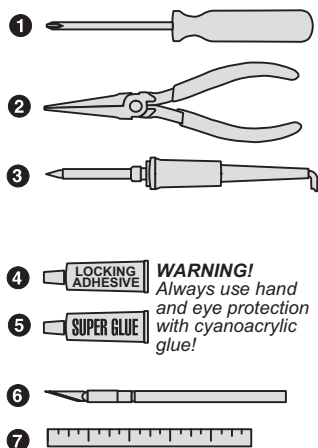

**WARNING!**  
Always use hand and eye protection with cyanoacrylic glue!

### WARNING!

Do not use a power screwdriver to install screws into nylon, plastic, or composite materials. The fast rotation speed can heat up the screws being installed. They can then break the molded parts or strip the threads during installation.

## ITEMS NEEDED TO COMPLETE YOUR KIT

- 1 R/C two channel surface frequency radio system.
- 2 \*Battery pack (6 cell).
- 3 \*Battery charger (we recommend a peak detection charger).
- 4 \*Electronic speed control.
- 5 \*R/C electric motor.
- 6 \*Pinion gear, size to be determined by type and wind of motor you will be using.

\*Available from Team Associated. See your catalogs.

# CONTACTING US

## CUSTOMER SUPPORT

(714) 850-9342  
 Fax (714) 850-1744  
<http://www.rc10.com/help>



©2003 Associated Electrics, Inc.

## ASSOCIATED ELECTRICS, INC.

3585 Cadillac Ave.  
 Costa Mesa, CA 92626  
 USA  
<http://www.TeamAssociated.com/>

# BEFORE BUILDING

## OPEN THE BAGS IN ORDER

The assembly is arranged so that you will open and finish that bag before you go on to the next bag. **Sometimes you will have parts remaining at the end of a bag. These will become part of the next bag.**

## LEFT AND RIGHT

When we refer to left and right sides of the truck, we are referring to the driver's point of view while sitting in the truck.

## SUPPLEMENTAL SHEETS

Improvements to our kits, if any, will be noted in supplementary sheets located in a parts bag or inside the kit box. Check the kit box before you start and each bag as it is opened. When a supplement is found, attach it to the appropriate section of the manual.

◀1:1▶ = Actual size part.      x2 = Quantity for step.  
 Rear x2 = Do entire step twice.      ! = Pay attention to this detail.

# BAG A

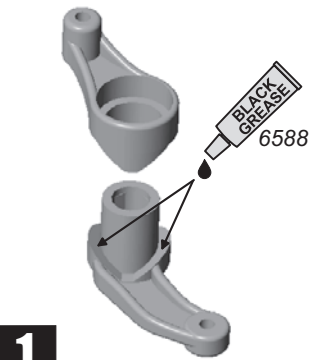
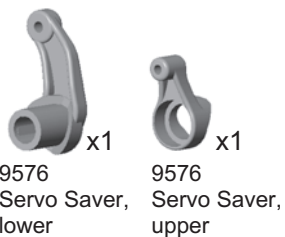

1

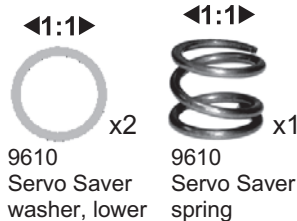

2

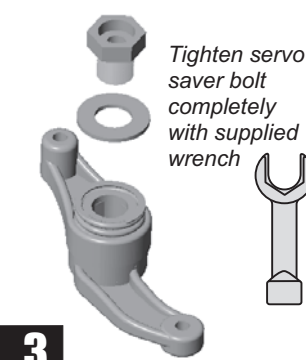
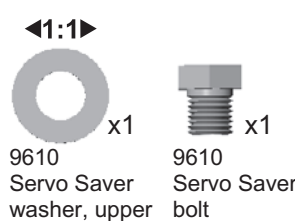

3

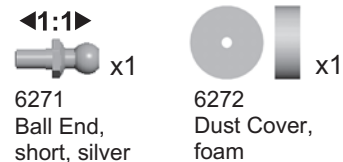

4

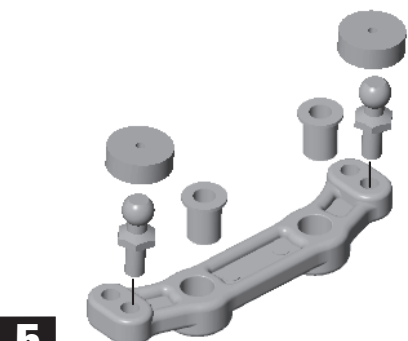
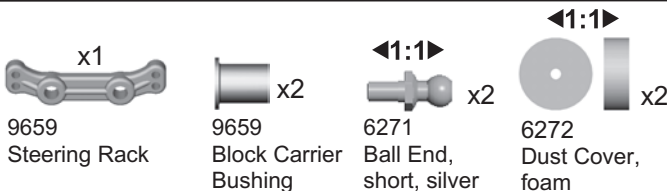

5

### NOTE

Install ball ends here only when using **OPTIONAL** inline axles #9577, 9623

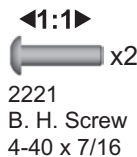

6

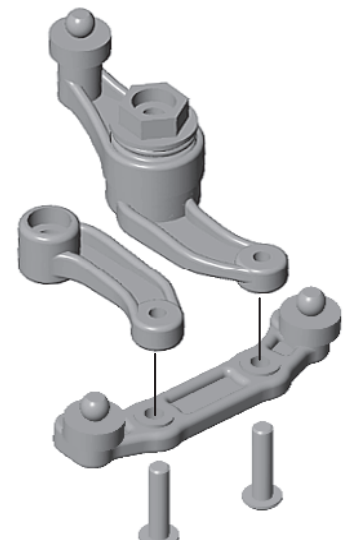

3

# BAG A

- 9566 Top Plate x1
- 3856 Steering Rack Bushing x4
- 9659 Steering Brace x1
- 9640 Steering Bolt, right x1
- 9640 Steering Bolt, left x1

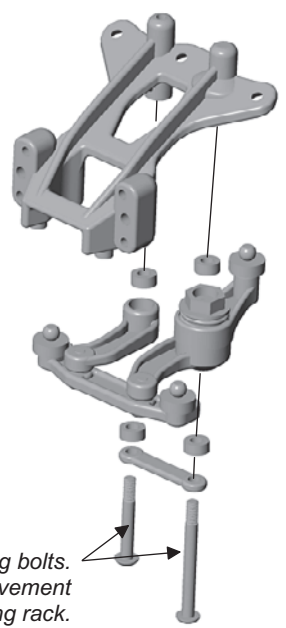

*Do not overtighten steering bolts. Make sure there is free movement in the steering rack.*

**7**

- 9563 Front Bulkhead x1
- 6925 S. H. Screw 4-40 x 1/2 x3
- 6915 F. H. Screw 4-40 x 5/8 x2
- 7440 T4 Chassis x1

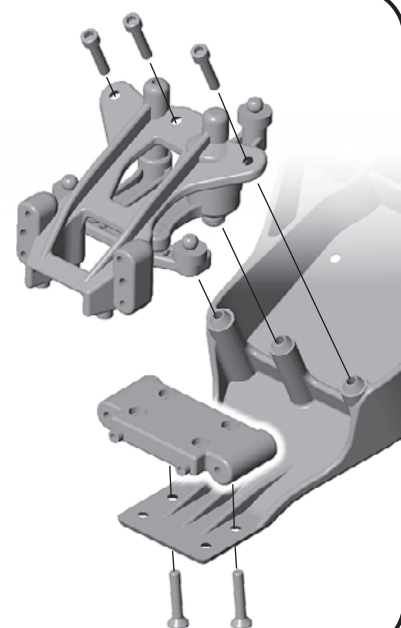

**8**

# BAG B

- 9581 Steering Block, right x1
- 9581 Steering Block, left x1
- 6272 Dust Cover, foam x2
- 6273 Ball End, long, silver x2
- 6299 E-clip x2
- 4187 .030 Washer x2
- 7456 Front Axle, trailing x2

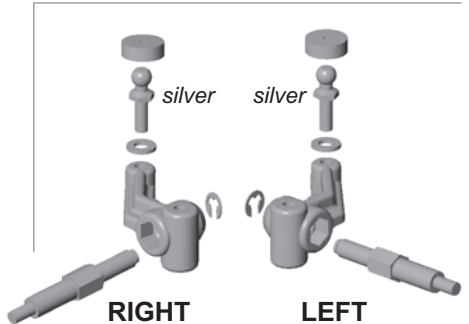

**1**

- 9580 25° Caster Block, right x1
- 9580 25° Caster Block, left x1
- 6272 Dust Cover, foam x2
- 3858 Ball End, long, black x2

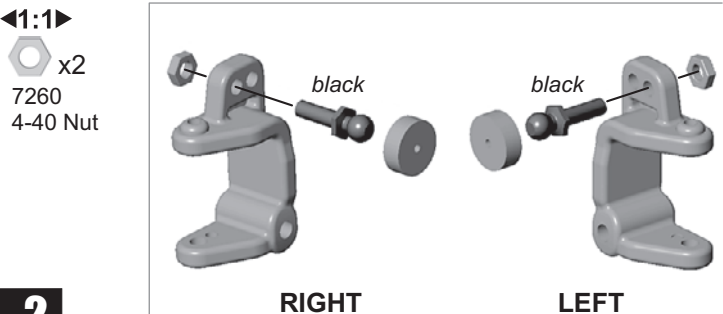

**2**

- 9622 Kingpin x2
- 4187 .030 Washer x4
- 9645 B. H. Screw 2-56 x 1/8 x2

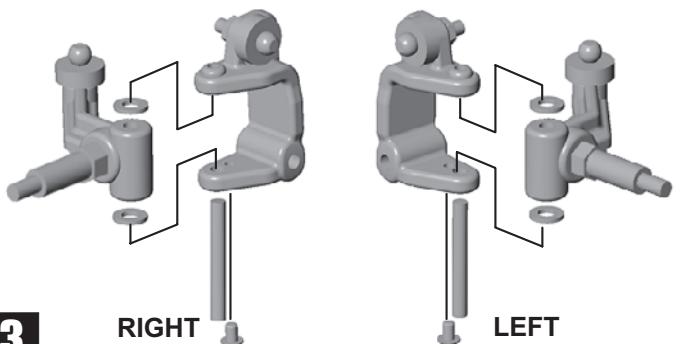

**3**

**STEPS 1-3 ASSEMBLED RIGHT**

**STEPS 1-3 ASSEMBLED LEFT**

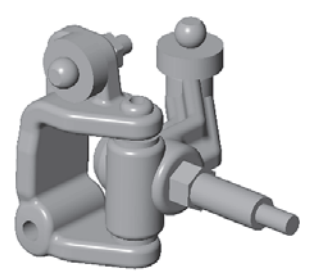
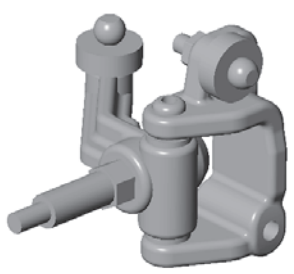

**4**

# BAG B

- x2 7446 A-arms, front
- 9580 Spacer
- 9645 B. H. Screw 2-56 x 1/8
- 9622 Hinge Pin, front outer

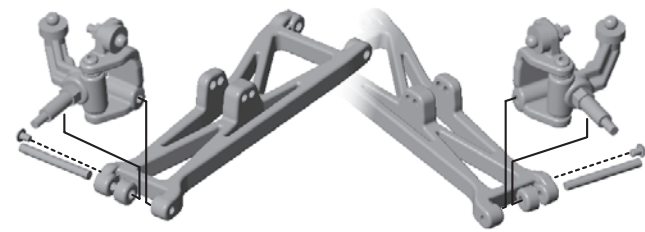

RIGHT

LEFT

4

- x1 9564 Front Hinge Pin Brace
- 9621 Hinge Pin, front inner
- 9645 B. H. Screw 2-56 x 1/8
- 4334 B. H. Screw 2-56 x 5/16

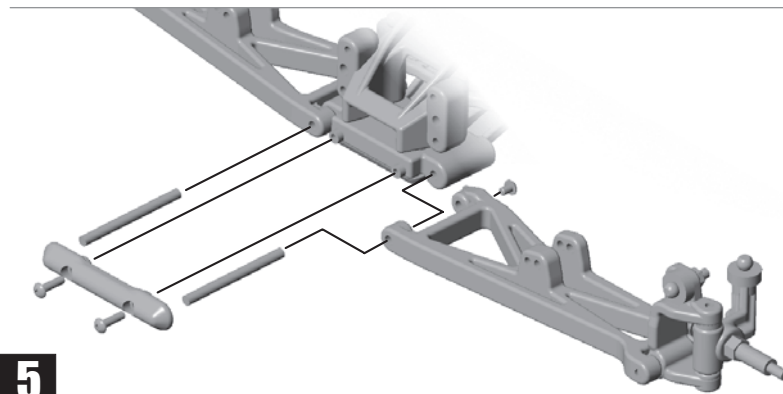

5

- 6272 Dust Cover, foam
- 6273 Ball End, long, silver
- 9630 washer
- 6295 4-40 nut
- 7442 Front Shock Tower
- 6924 S. H. Screw 4-40 x 3/8

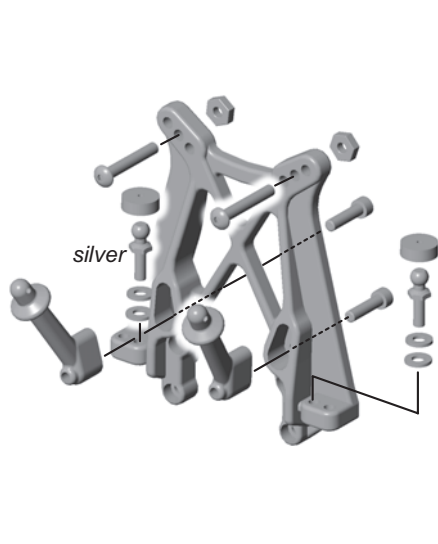
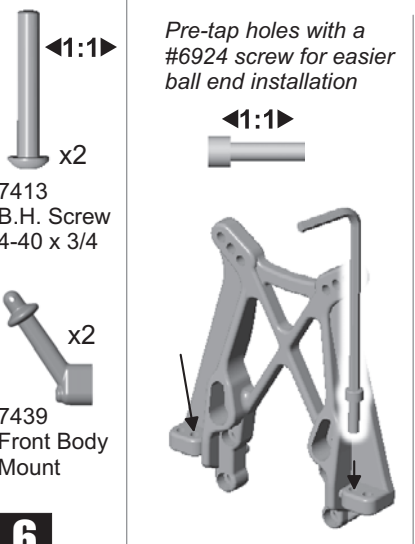

6

- 9562 Front Bumper
- 6924 S. H. Screw 4-40 x 3/8
- 6915 F. H. Screw 4-40 x 5/8

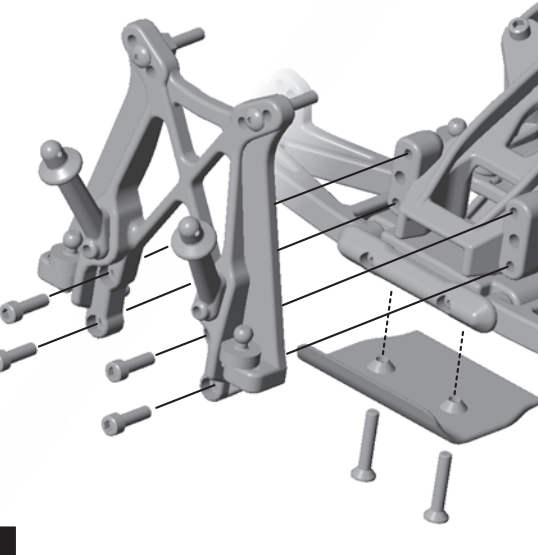

7

- 7253 2.62" Turnbuckle
- 7230 Ball Cup, large
- 7101 2.80" Turnbuckle

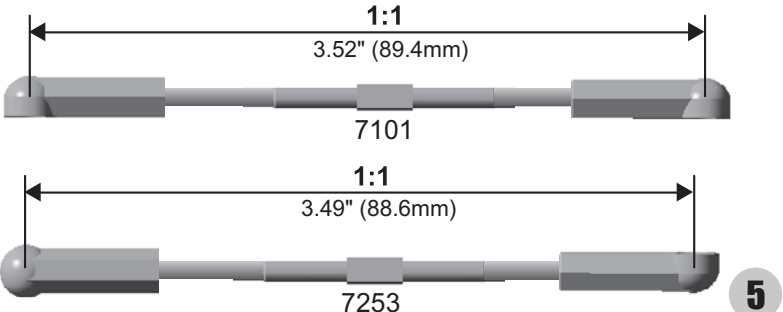
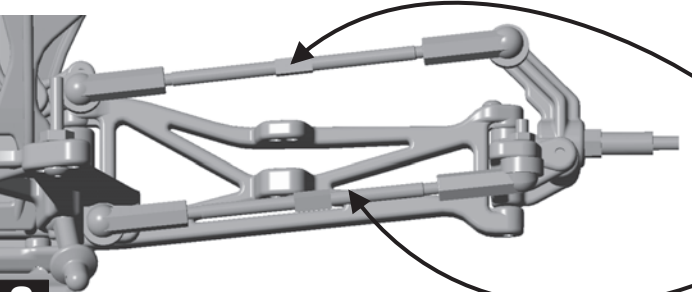

8

5

# BAG C

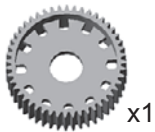

7664  
Diff Gear, 52T

◀1:1▶  
● x12

6581  
Carbide Diff Balls  
3/32

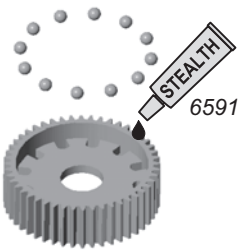

Fill ball holes  
with Stealth lube

1

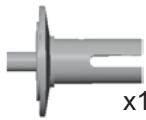

7668  
Diff Outdrive  
Hub, left



7666  
Diff Ring



Apply Stealth lube  
to rim

2

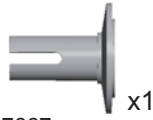

7667  
Diff Outdrive  
Hub, right



7666  
Diff Ring



Apply Stealth lube  
to rim

3

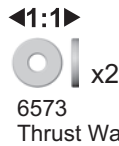

◀1:1▶  
● x6

6574  
Diff Thrust Ball,  
5/64

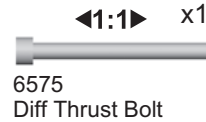

6575  
Diff Thrust Bolt

4

Apply Black Grease  
to washer to hold balls  
in place



6589  
Ball Bearing,  
5/32 x 5/16



6

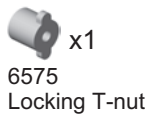

6575  
Locking T-nut



6582  
Diff Thrust Spring



Compress spring first.

7

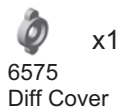

6575  
Diff Cover

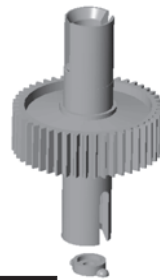

8

## SETTING THE DIFFERENTIAL

As you tighten the diff bolt, you will notice the T-nut ears moving closer to the bottom of the outdrive slot. This compresses the spring behind the T-nut. The spring should be completely compressed at the same time the T-nut reaches the end of the slot.

**Caution:** Pay close attention to the feeling when the spring is completely compressed. Do not overtighten the bolt. When you feel the spring completely compressed, loosen the diff bolt 1/8 of a turn. Your diff should now operate smoothly with resistance as the outdrives move in opposite directions. **After you have driven the car once, recheck the diff setting.**

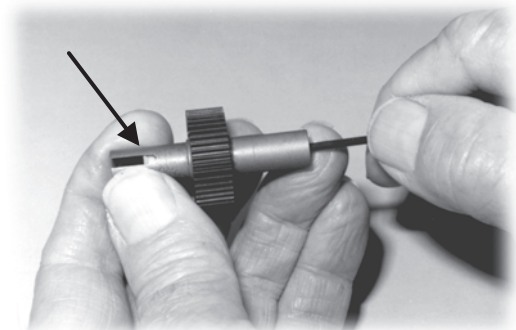

9



5

# BAG C

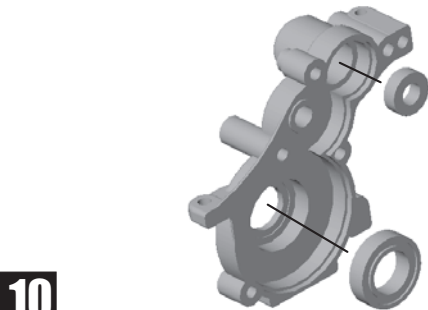
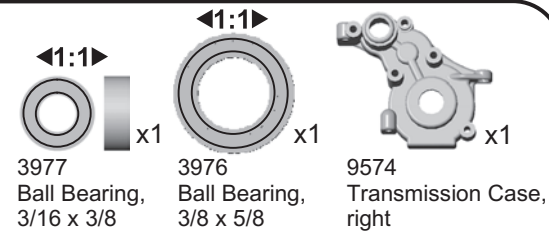

10

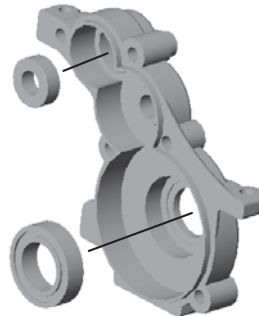
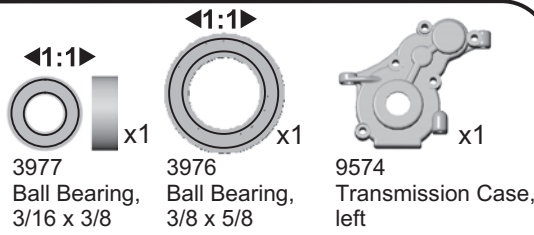

11

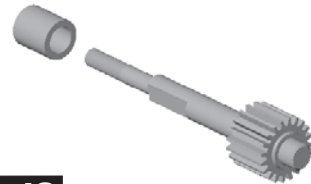
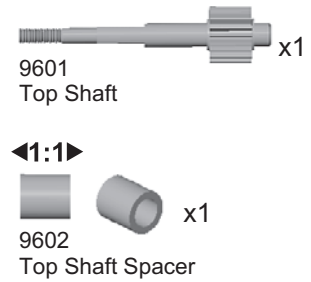

12

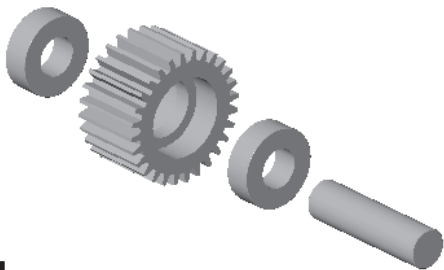

13

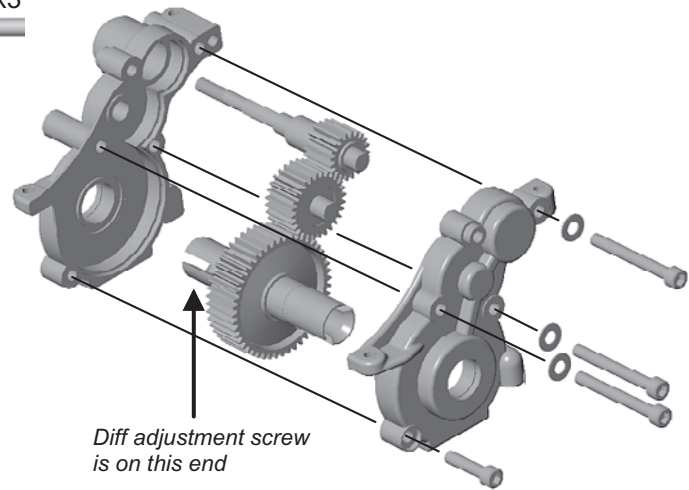
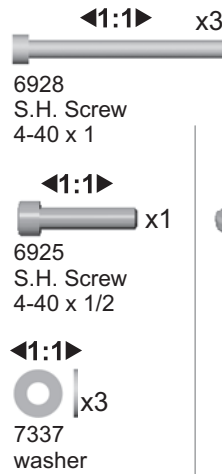

14

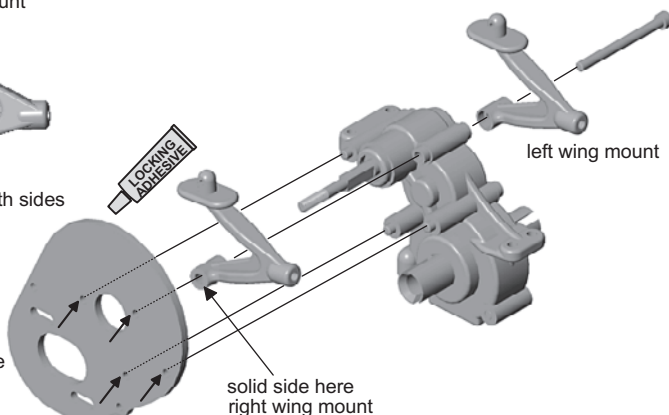
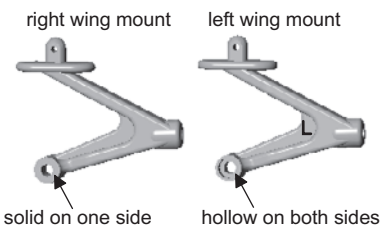
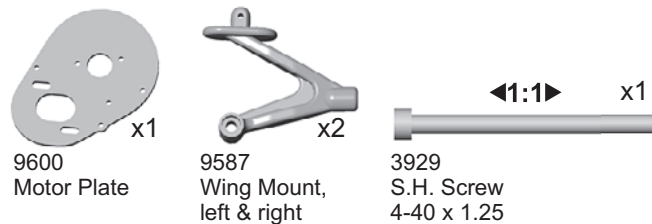

**Racer's Tip:**  
Apply a small amount of locking adhesive to these holes to prevent screws from loosening.

solid side here  
right wing mount

15

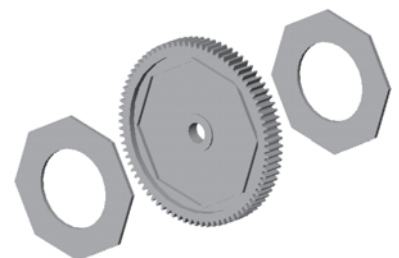
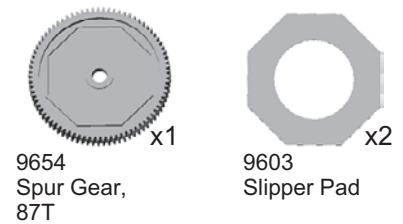

Press pads into spur gear.

16

7

# BAG C

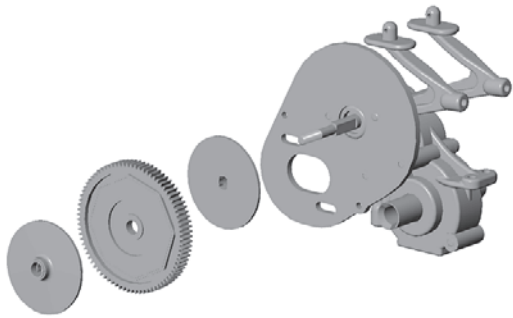
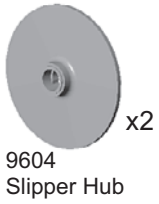

17

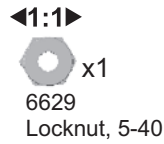

Install locknut until even with end of shaft. Then tighten 3 turns for kit slipper setting. Recheck after initial run.

Compress spring first.

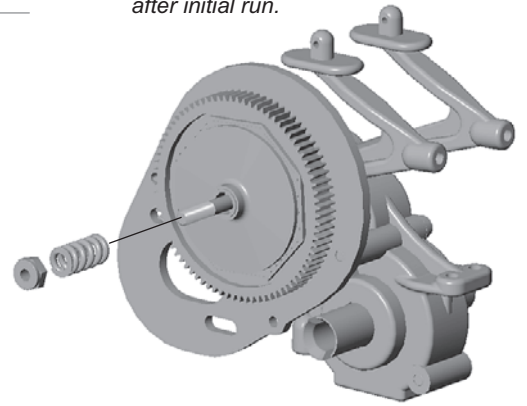

18

# BAG D

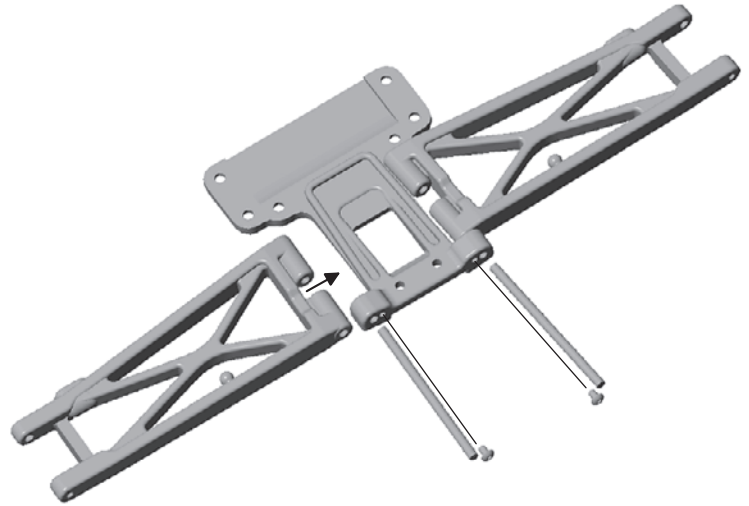
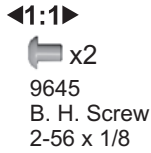
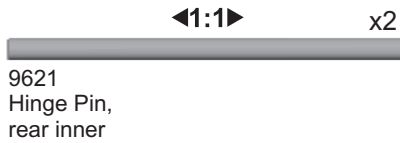
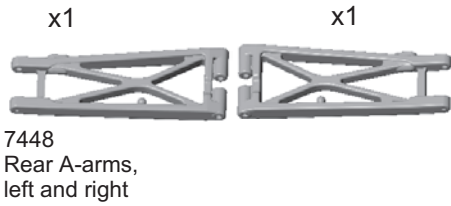
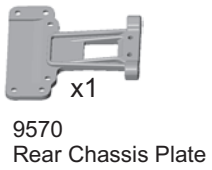

1

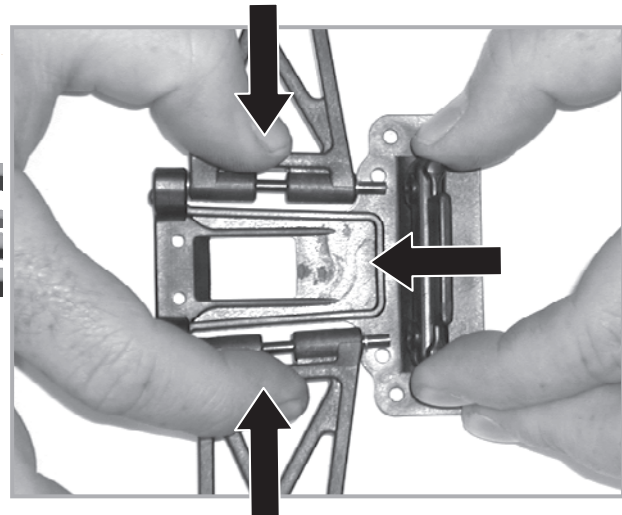
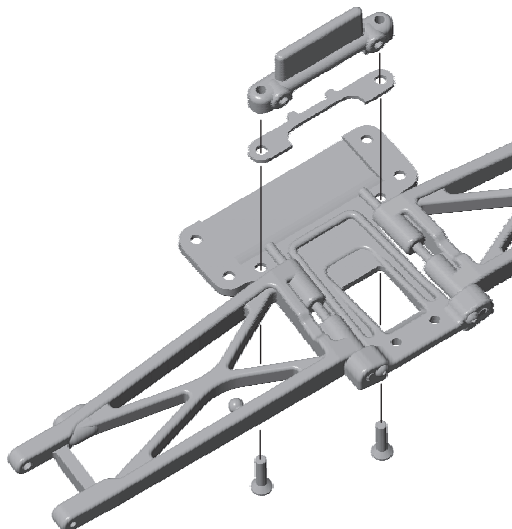
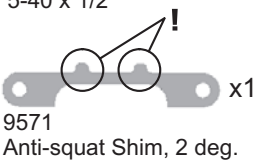
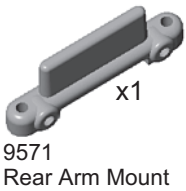

8

2



# BAG D

- ◀1:1▶ x4  
9269  
S. H. screw,  
5-40 x 1/2

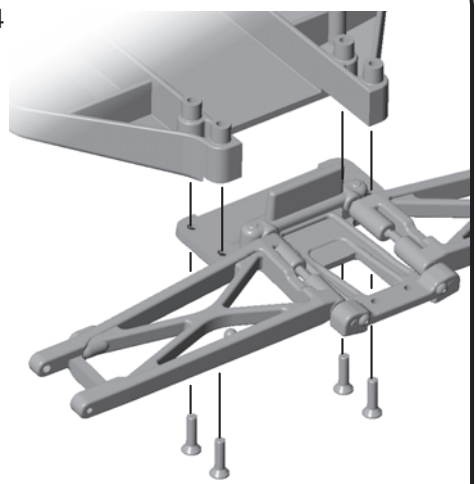

3

- ◀1:1▶ x2  
6272  
Dust Cover,  
foam
- 9564  
Brace x1

- ◀1:1▶ x2  
6273  
Ball End,  
long, silver
- ◀1:1▶ x2  
9630  
washer

*Pre-tap holes with a #6924 screw for easier ball end installation*

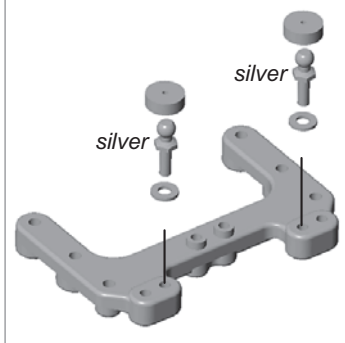
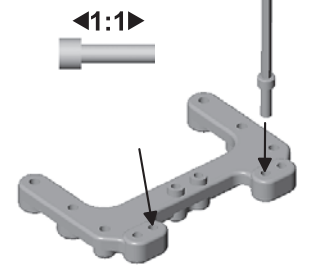

4

- ◀1:1▶ x2  
9643  
S. H. Screw  
5-40 x 7/16

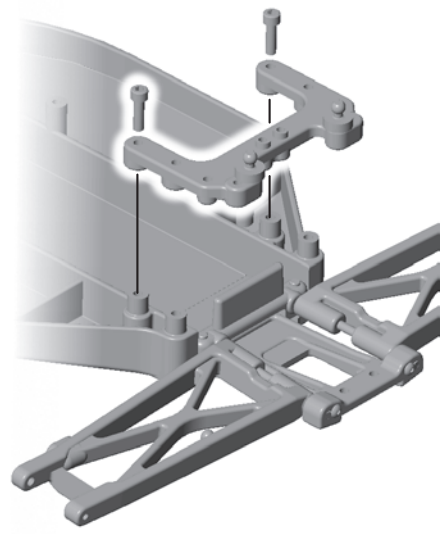

5

- ◀1:1▶ x2  
7413  
B. H. screw,  
4-40 x 3/4

- ◀1:1▶ x2  
7260  
4-40 nut
- 7444  
Rear Shock Tower



6

- ◀1:1▶ x2  
9644  
S. H. screw,  
5-40 x 9/16

- ◀1:1▶ x2  
9643  
S. H. screw,  
5-40 x 7/16

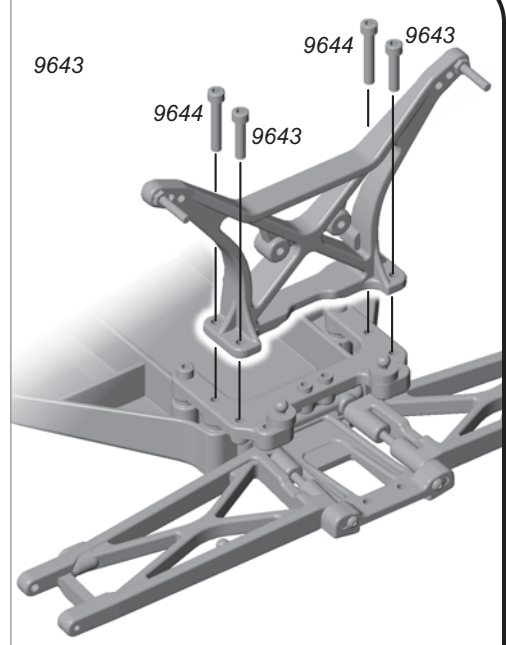

7

- ◀1:1▶ x2  
6925  
S. H. screw,  
4-40 x 1/2

- ◀1:1▶ x2  
6915  
F. H. screw,  
4-40 x 5/8

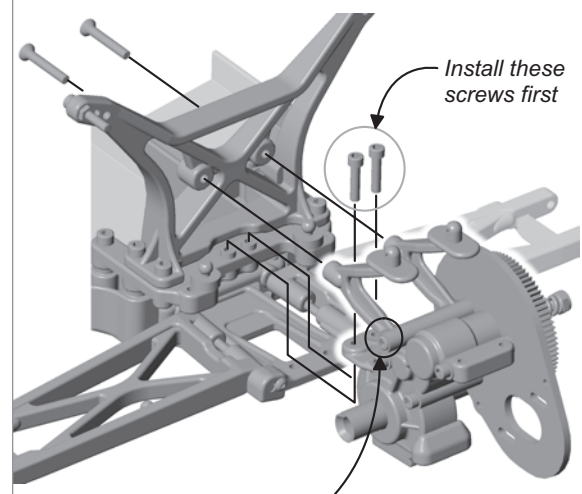

*Tighten screw from step C15*

8

9

# BAG D

- ◀1:1▶ x2  
6919 B. H. screw, 4-40 x 5/16
- ◀1:1▶ x2  
6922 F. H. screw, 4-40 x 1/2
- x1  
9575 Motor Guard

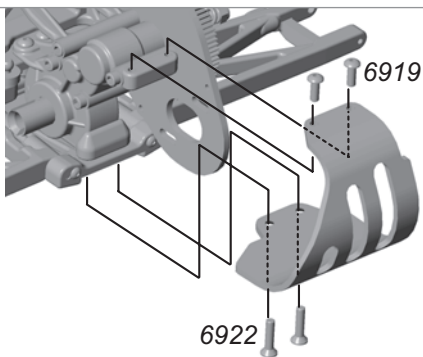

9

# BAG E

- ◀1:1▶ x2  
6272 Dust Cover, foam
- ◀1:1▶ x2  
3858 Ball End, black
- x1  
9584 Rear Hub Carriers, left and right

- ◀1:1▶ x2  
7260 Plain Nut

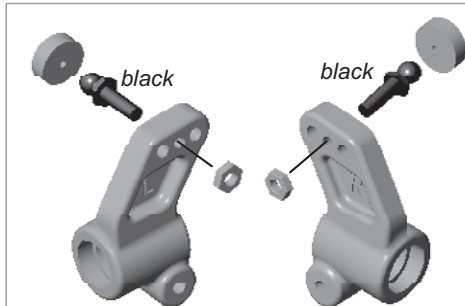

1

- ◀1:1▶ x2  
7377 Bearing Spacer
- ◀1:1▶ x4  
3977 Ball Bearing, 3/16 x 3/8

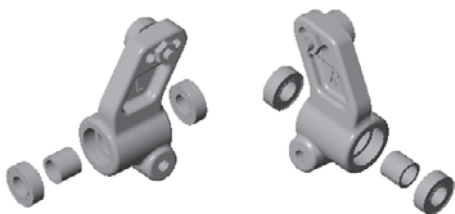

2

- x2  
9598 MIP CVD Axle
- x2  
7381 CVD Coupling

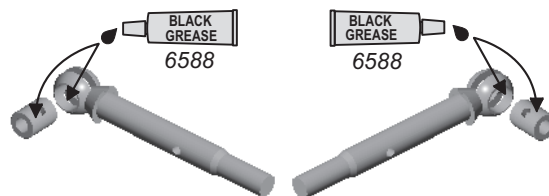

3

- x2  
7453 CVD Bone
- ◀1:1▶ x2  
7381 CVD Cross Pin
- ◀1:1▶ x2  
7381 Set Screw

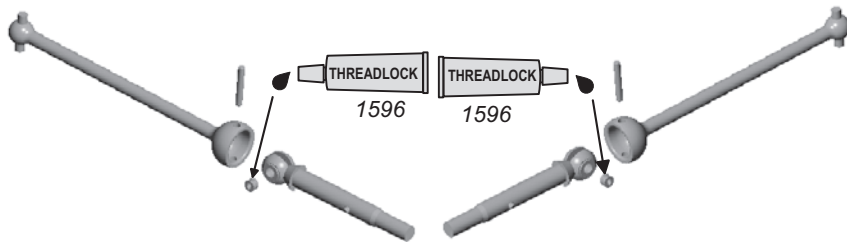

4

- ◀1:1▶ x2  
9608 Wheel Spacer
- ◀1:1▶ x4  
7368 3/16 Axle Shim
- ◀1:1▶ x2  
7369 Roll Pin

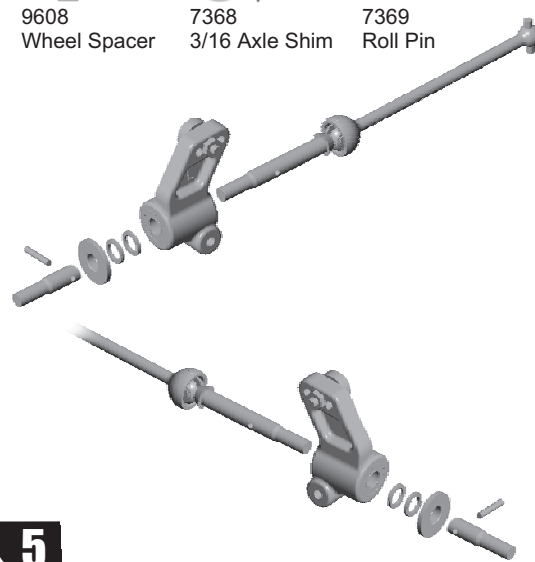

5

10

# BAG E

## x2

◀1:1▶ x1



9622  
Hinge Pin,  
rear outer

◀1:1▶ x1



9645  
B.H. Screw  
2-56 x 1/8

◀1:1▶



4187  
Spacer

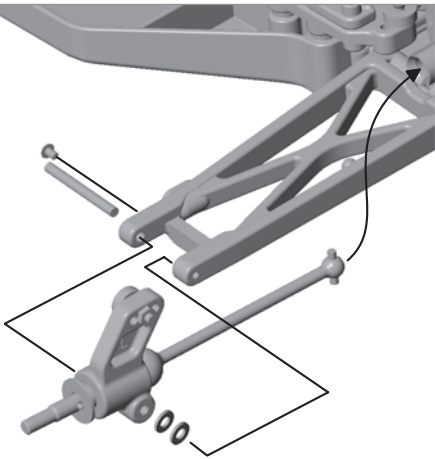

### 6

# x2

◀1:1▶

x1



7101  
Turnbuckle, 2.80"



7230  
Ball Cup

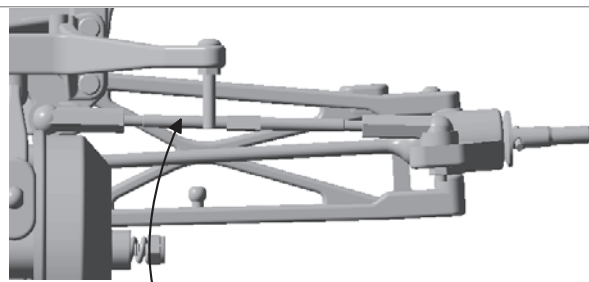

1:1  
3.52" (89.4mm)

### 7

# BAG F

## Front x2



6440  
Clamp



6440  
Thick Washer



6440  
Thin Washer



5407  
Red O-ring



remove burrs

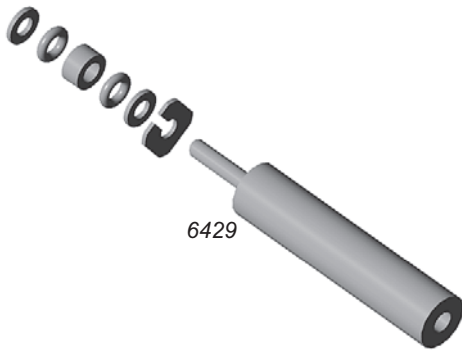

6429

### 1

## Front x2

◀1:1▶

x1



6436  
Front Shock Body  
hard anodized, 1.02"



5422  
Racer's Tip:  
Use Green Slime  
#1105 shock lube  
instead of oil.

Place on table  
and push down  
hard until clamp  
snaps into place

### 2

## Front x2



6469  
Shock Cap O-ring



### 3

## Front x2



6299  
E-clip



6465  
Shock Piston #2



6459  
Shock Shaft, 1.02 stroke



6466  
Shock Downstop (Limiter), 1/32



remove burrs

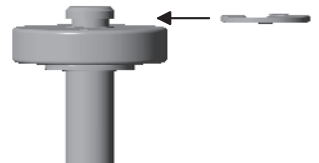
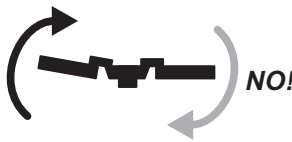

### 4

### 11



**BAG F****Front x2**

x1

7217  
Pivot Ball

x1

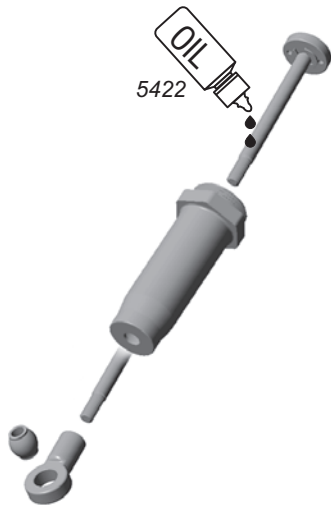
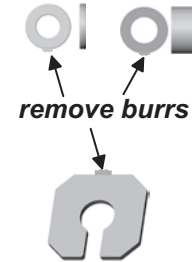
7217  
Eyelet**5****BAG F****Rear x2**6440  
Clamp6440  
Thick Washer6440  
Thin Washer5407  
Red O-ring**REAR SHOCKS**

remove burrs

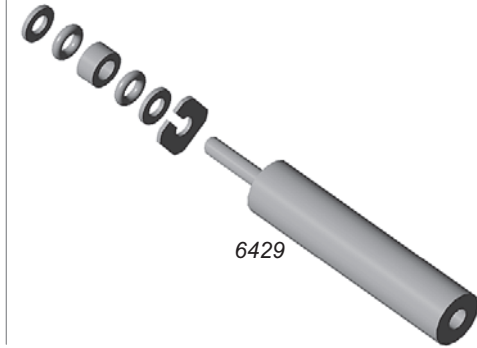

6429

**6****BAG F****Rear x2**

1:1

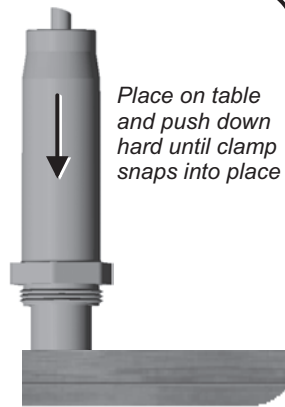

5422

**Racer's Tip:**  
Use Green Slime  
#1105 shock lube  
instead of oil.Place on table  
and push down  
hard until clamp  
snaps into place

x1

7410  
Rear Shock Body  
hard anodized, 1.39**7****Rear x2**6469  
Shock Cap O-ring**8****Rear x2**6299  
E-clip6465  
Shock Piston #16458  
Shock Shaft, 1.32 stroke

x1

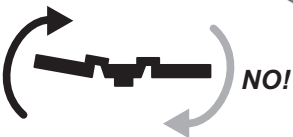
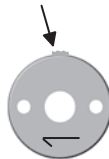

remove burrs

**9****Rear x2**

x1

7217  
Pivot Ball

x1

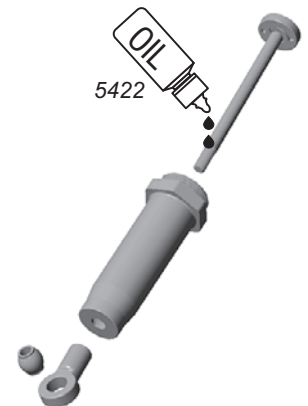
7217  
Eyelet

5422

**10**

# BAG F

5422

OIL

Fill to top with oil

**11**

Move shaft up and down to remove air bubbles

**12**

5422

OIL

Fill to top with oil

**13**

Push the shaft in

**14**

5422

OIL

6428 Shock Cap, molded

**1** Fill cap with oil

**2** Retain oil as you screw cap on

**Tightening your shock cap**

**15**

Move the shock shaft in and out a few times. Then push it all the way in

**16**

The shaft should push itself out by the amount shown

1/4" to 3/8"  
(6.3mm - 9.5mm)

**17**

If the shaft does not push out that far, do steps 15-17 again

**A**

If the shocks push out farther than the distance in step 17, or you cannot push the shaft in until the eyelet hits the body, there is too much oil. Loosen the cap a half turn (with the shaft extended) and pump out a small amount of oil by pushing the shaft in. Retighten the cap and try steps 15-17 again.

**B**

## Front x2

7428 Spring, silver x1

6475 Spring Collar x1

6475 Spring Cup x1

8846 Preload Spacer, 1 each of .12, .06, .03

**4** Install spring, then compress to insert cup

**18**

## Rear x2

6475 Spring Collar x1

6480 Spring, green x1

8846 Preload Spacer, 2 each of .25, 1 each of .12

6475 Spring Cup x1

**4** Install spring, then compress to insert cup

**19**

# BAG F

# Front x2

◀1:1▶  
 6472  
 4-40/5-40 Plastic Nut

6473  
 Shock Bushing

◀1:1▶ x1  
 7738  
 S.H. Screw  
 4-40 x 7/8

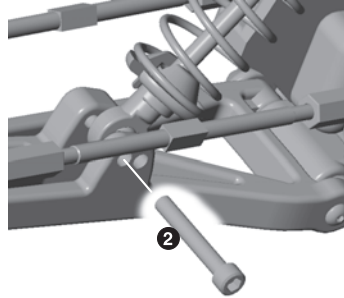
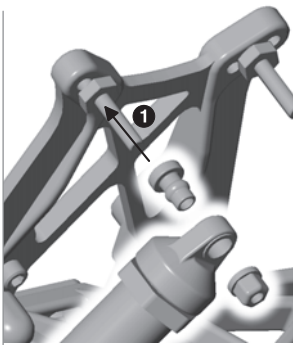

# Rear x2

◀1:1▶  
 6472  
 4-40/5-40 Plastic Nut

6473  
 Shock Bushing

◀1:1▶ x1  
 6925  
 S.H. Screw  
 4-40 x 1/2

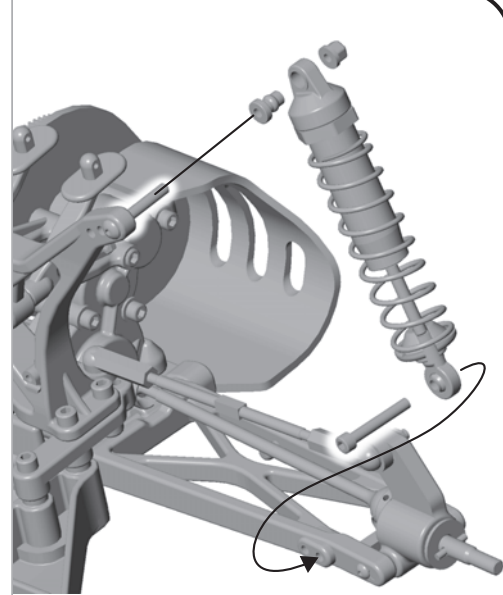

20

21

# BAG G

1  
**FIND YOUR SERVO TYPE**

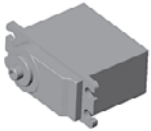

2  
**SELECT YOUR SPACER(S)**



3  
**SELECT YOUR SERVO HORN**



1  
**STEERING SERVO TYPE**  
*(Steering servo is sold separately)*  
**NOT ALL SERVOS ARE LISTED**



2  
  
**#7337  
 SPACER**

3  
  
**#9180  
 SERVO  
 ARM**

**Airtronics**  
 94102

**Airtronics**  
 94738, 94157, 94158, 94257, 94258, 94357, 94358, 94452, 94453, 94751, 94755

**Hitec**  
 HS-5625MG, HS-5645MG, HS-625MG, HS645MG

**Hitec**  
 HS-303, HS-300BB, HS-945MG, HS-925MG, HS-5945MG, HS-5925MG, HS-525MG, HS-525BB, HS-425BB, HS-422

**JR**  
 Z4725, Z4750, Z2750, Z8450, Z8550, NES-4750

**JR**  
 Z250, Z550

**Futaba**  
 S9204, S9250, S9450, S148

**Futaba**  
 S3003, S9202, S9101

**Futaba**  
 S9404

**KO**  
 PS-401, PS-2001, PS-2004, PS-2015, PS-2173, PS-2174, PS-2123, PS-2143, PS-2144

no spacer

**A**

thick spacer

**A**

no spacer

**H**

thin spacer

**H**

no spacer

**J**

thin spacer

**J**

no spacer

**F**

thin spacer

**F**

thick spacer

**F**

thin spacer

**J**

◀1:1▶  
 6272  
 Ball End Dust Cover



9180  
 Servo Horn

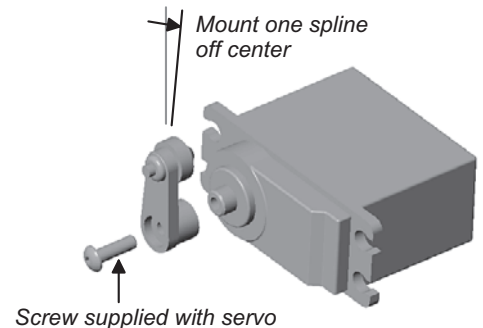

◀1:1▶  
 3858  
 Ball End, black



2

16

-  x2
-  x0 or x2

-  x4
-  x4

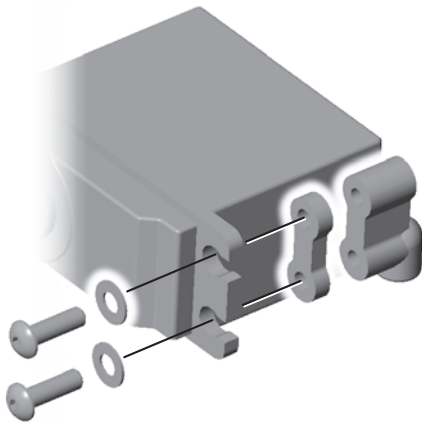

-  x2
- 9170 Servo Link Cup
-  x1
- 9170 Servo Link

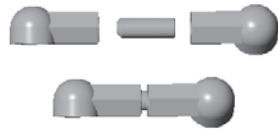



3

4

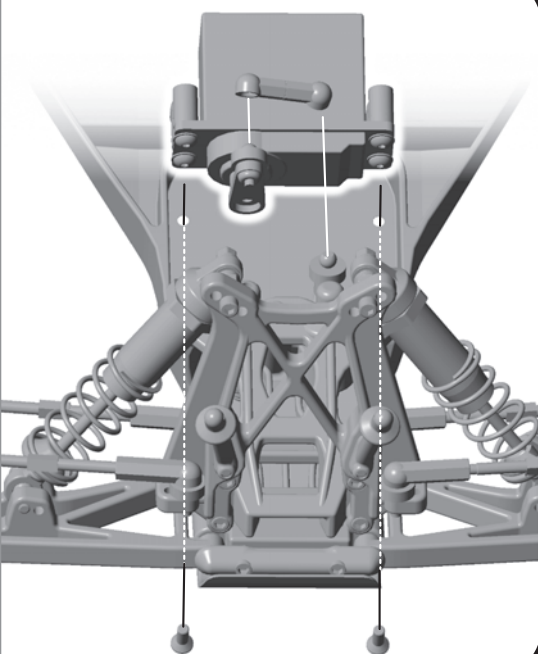
-  x2
- 7673 F. H. Screw 4-40 x 5/16



5

-  x2
- 3934 B.H. screw 3mm
-  x2
- 6936 Washer

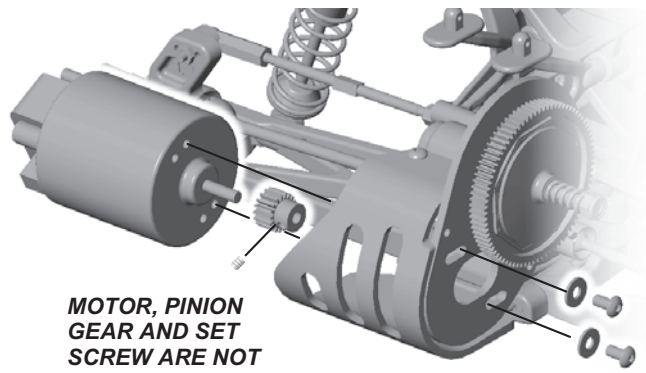

6

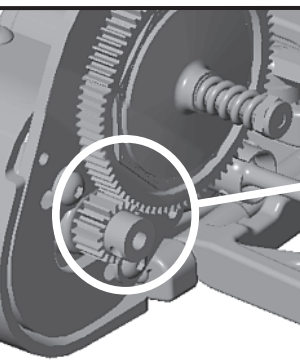

**SET THE GEAR MESH**  
 You should be able to rock the spur gear back and forth in the teeth of the pinion gear without making the pinion gear move. If the spur gear mesh is tight, then loosen the #3934 screws and move the motor away, then try again. A gear mesh that is too tight or too loose will reduce power and damage the gear teeth.

7

-  x2
- 6920 B.H. screw 4-40 x 3/16
-  x1
- 9609 Gear Cover

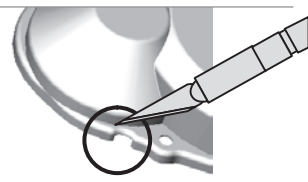
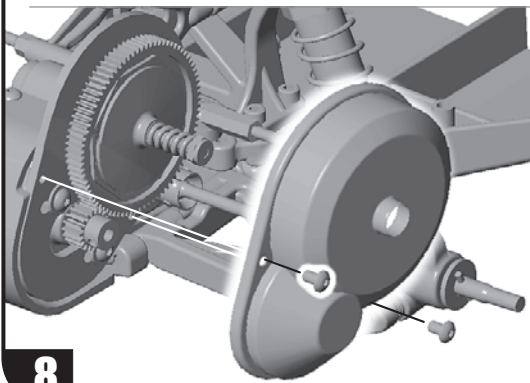

8

17



1. Feed ESC wire through holes as shown.
2. Attach servo tape under ESC and attach ESC where shown.
3. Feed antenna wire through antenna mount.
4. Attach servo tape under receiver and attach receiver where shown.
5. Thread ESC wires through tower and connect to motor.
6. Plug ESC wire into receiver channel 2.
7. Plug steering servo wire into receiver channel 1.
8. Thread antenna wire up antenna tube. Add antenna cap to end of tube.
9. Screw two #6929 bolts where shown, leaving 1/16" gap.

◀1:1▶

6929  
4-40 x 3/8 S.H. Screw  
with hole

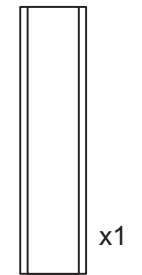

6727  
Servo Tape  
double-sided



6338  
Antenna and  
Antenna Cap

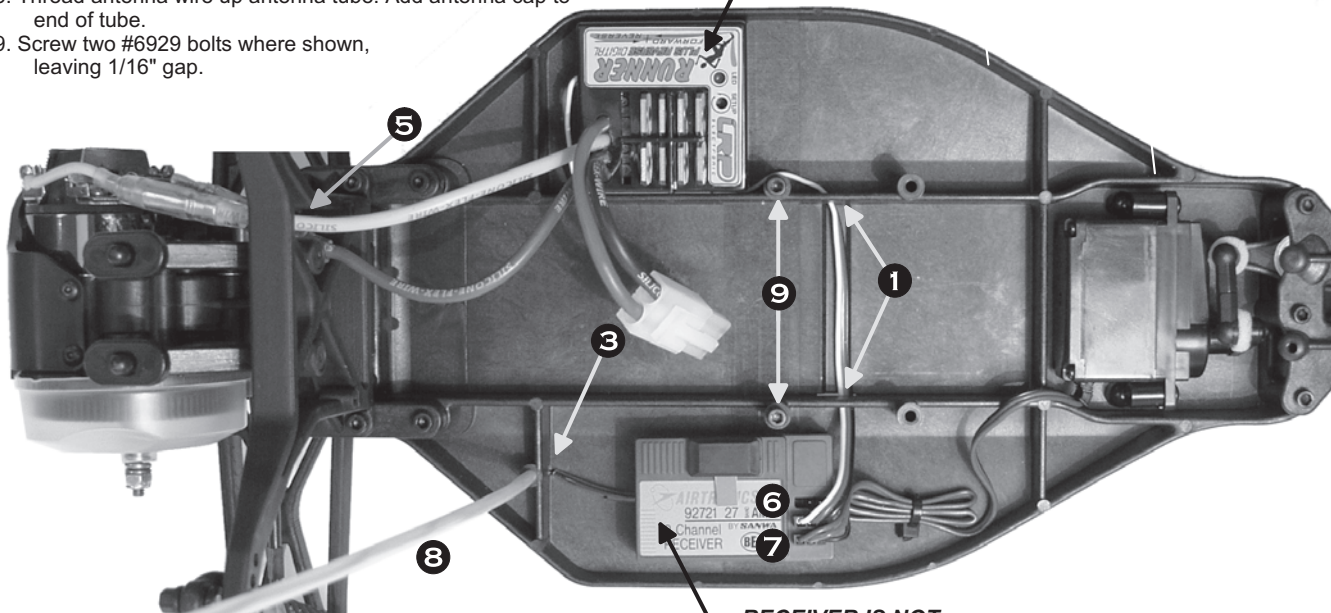

2 SPEED CONTROL (ESC)  
IS NOT INCLUDED IN KIT

4 RECEIVER IS NOT  
INCLUDED IN KIT

9



6332  
Body Clip

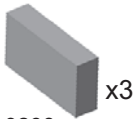

9238  
Battery Spacer Block



7450  
Battery Holddown Strap

Your **OPTIONAL** batteries may come in stick pack form, shown here.



**CONNECT BATTERY  
PLUG TO ESC PLUG**

If you need help on  
assembling your battery  
pack, please see page 20.

**BATTERIES  
ARE SOLD  
SEPARATELY**

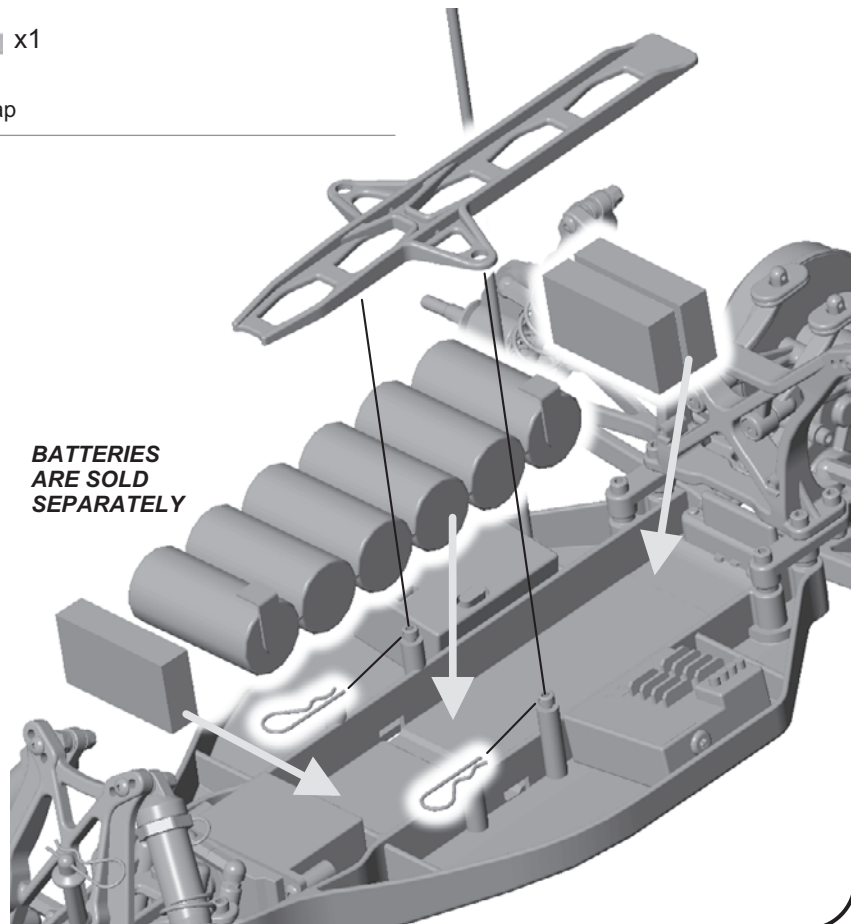

10

# BAG H

# Kit only--Front x2

- 7463 Front Wheel x1
- 7466 Front Tire x1
- 7466 Front Insert x1

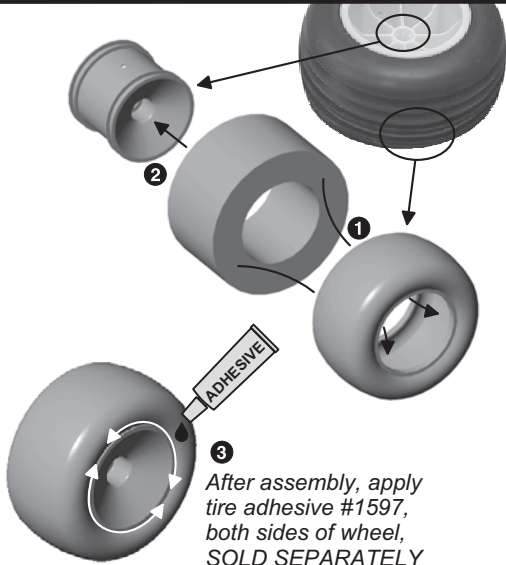

After assembly, apply tire adhesive #1597, both sides of wheel, SOLD SEPARATELY

1

# Kit only--Rear x2

- 7464 Rear Wheel x1
- 7465 Rear Tire x1
- 7465 Rear Insert x1

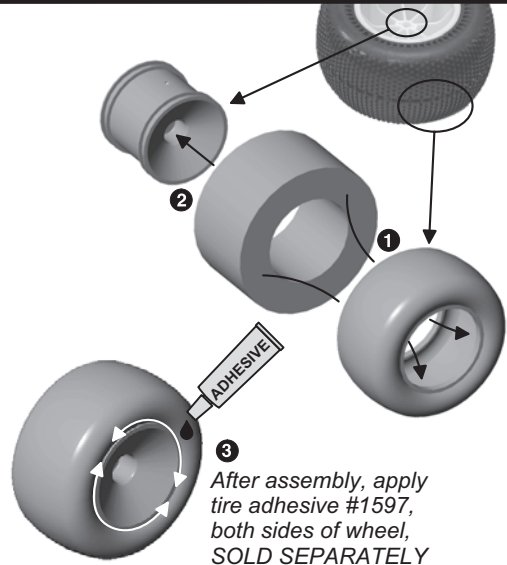

After assembly, apply tire adhesive #1597, both sides of wheel, SOLD SEPARATELY

2

# Front x2

- 6222 4-40/5-40 locknut x1
- 3977 3/16 x 3/8 ball bearing x2

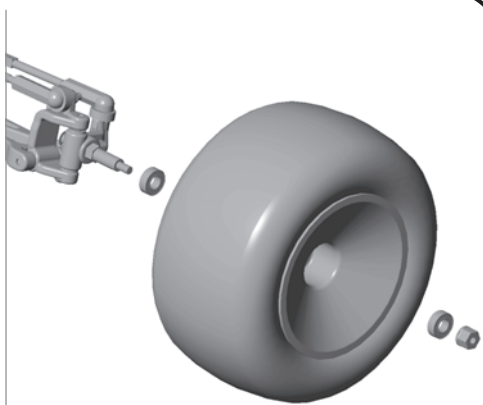

3

# Rear x2

- 3438 8-32 Alum. Locknut x1

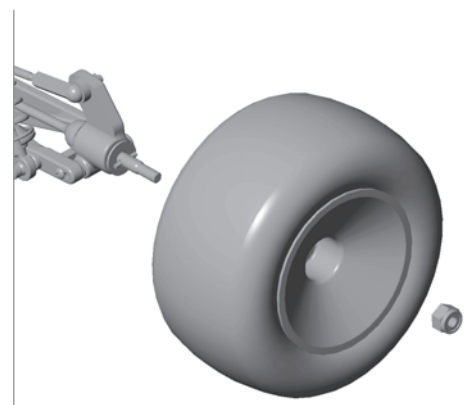

4

- 9587 Wing Angle Shim x2

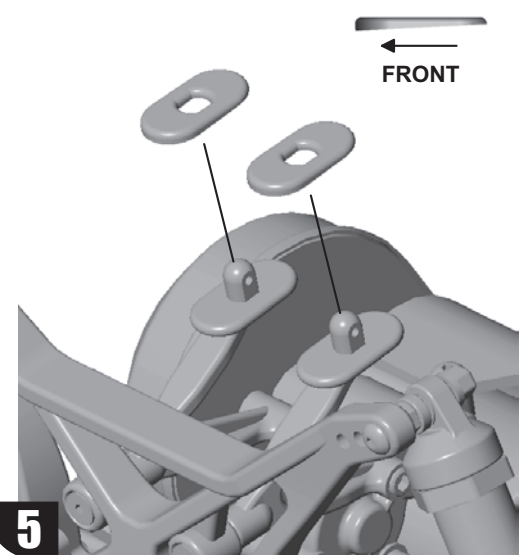

5

- 6332 Body Clip x4

- 7457 Body & Spoiler x1

- 6288 4-40 x 1/4 BH Screw x2

- 6472 4-40/5-40 Plastic Nut x2

Trim and paint body and wing

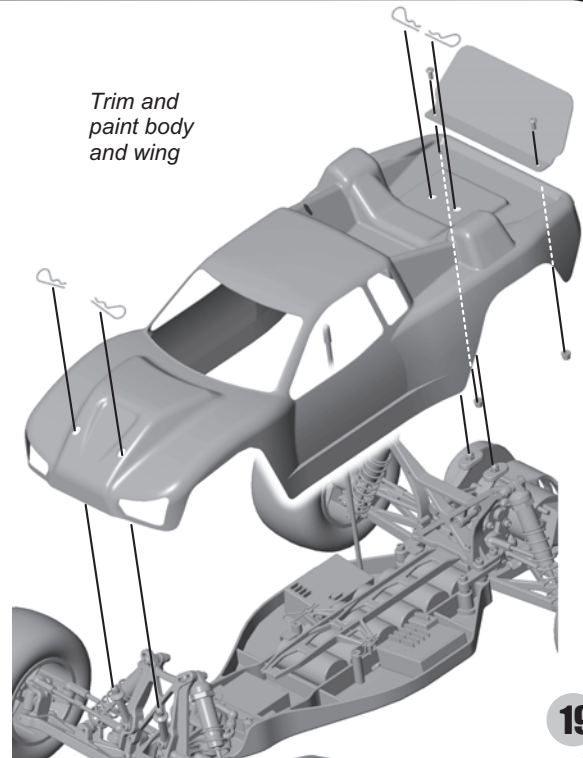

6

19

## FINAL ADJUSTMENTS

### RADIO ADJUSTMENTS

Use the following steps to make the final adjustments on your car.

1. Turn the transmitter on.
2. Make sure the motor is disconnected.
3. Connect your battery pack and turn the power switch on.
4. Move the steering control on the transmitter to the right and left. Do the wheels move in the correct direction? If not, you must reverse the steering servo direction on your transmitter (see radio manual.)
5. Adjust your steering trim (see radio manual) until the #9576 steering rack is centered under the top plate. Then, using the two steering turn-

buckles, adjust the front wheels so they are pointing straight ahead.

6. Adjust the ESC (electronic speed control) according to the speed control manufacturer's instructions. *Some manufacturers have the motor connected during adjustment and some do not.* Now turn the power switch off.

7. Connect the motor. Place your car on a block or car stand so that all four wheels are elevated. Turn the power switch on again. Check the ESC and steering settings you have made and then turn the power switch back off.

8. Remember this! The transmitter is always the **FIRST TO BE TURNED ON** and the **LAST TURNED OFF**.

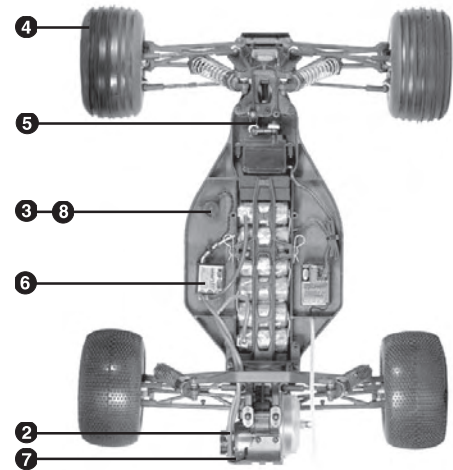

### ASSEMBLE BATTERY PACK

If you are not using a stick battery pack, here is how to assemble your battery pack. Solder individual cell connections as shown.

Team racers prefer battery bars for sturdier connections. Insulated wire will not allow the pack to fit in the battery slot.

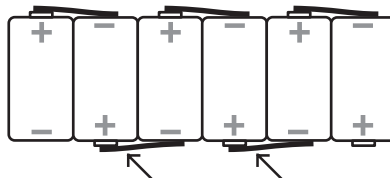

Solder connections with battery bars (#651)

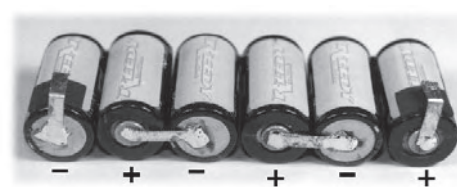

← Aim negative lead toward the front

### MOTOR GEARING

To get the most from your motor, proper gearing is important. The gear ratios listed in the chart are recommended starting gear ratios. Ratios can vary from track to track, but you should not change the pinion size more than one tooth from the recommended ratio.

**CAUTION!** Increasing the pinion size by more than one tooth can damage your motor from excess heat.

MOTOR	PINION	SPUR	FINAL DRIVE RATIO
24° stock (torque-based)	20	87	11.31:1
24° stock (RPM-based)	19	87	11.91:1
14 turn	19	87	11.91:1
14 turn modified motor	22	87	10.28:1
13 turn modified motor	21	87	10.77:1
12 turn modified motor	20	87	11.31:1
11 turn modified motor	19	87	11.91:1
10 turn modified motor	18	87	12.57:1

## MAINTENANCE

### CHECK FOR FIT

You should periodically check all the moving parts: front and rear end, suspension arms, steering blocks, steering linkage, shocks, and so on. If any of these should get dirty or bind then your car's performance will suffer.

### MOTOR MAINTENANCE

Between runs, inspect the brushes to ensure they are moving freely in the brush holder. This is done by carefully removing the spring and sliding the brush in and out of the holder. If there is any resistance or rough spots, remove the

brush and carefully wipe the brush clean. This will clean off any buildup so the brush slides smoothly in the brush holder.

After every 3 to 5 runs, remove the brushes from the holders and inspect the tips for wear and/or burning. If there is a noticeable amount of wear, replace the brush with a new pair. If the tip is a burnt blue color, then the lubricant in the brush has been burned away and new brushes should be installed.

After every other battery charge you should carefully clean the motor. One recommended

method is to spray motor cleaner directly on the brush and commutator area. Run the motor for approximately 15 seconds. Disconnect the motor and spray it again, making sure the runoff is clear and clean. If the runoff is still dirty, repeat the spraying action until clean. After completing the cleaning, apply a small amount of lightweight oil to each bushing or bearing for lubrication. Be careful not to apply too much oil, for this will pick up dirt and contaminate the commutator and brushes.

### DIFFERENTIAL

Adjust the differential ("diff") as noted on page 6. Adjusting the diff is not meant to be a tuning option. If you can hear the diff making a "barking" or "chirping" sound on jump landings, either your diff is set too loose or your slipper clutch is set too tight. First check your slipper setting, then re-set the diff according to the instructions on step C-9.

### SLIPPER CLUTCH

The assembly instructions give you a base setting for your clutch. Turn the nut on the shaft so that the end of the top shaft is even with the outside of the nut. Tighten the nut 3 more turns. At the track, tighten or loosen the nut in 1/8 turn increments until you hear a

faint slipping sound for 1-2 feet on takeoffs.

Another popular way to set the clutch is to hold both rear tires firmly in place and apply short bursts of throttle. If the clutch is properly set, the front tires should lift slightly up off the surface.

## TUNING & SETUP TIPS

*These steps prepare your buggy for maximum performance*

### FRONT CAMBER LINKS

Changing the length of the camber link is considered a bigger step than adjusting the ball end height on the tower. Shortening the camber link (or lowering the ball end) will give the front end less roll and quicken steering response. Lengthening the camber link (or raising the ball end) will give the front more roll and slower steering response.

Longer camber links are typically used on high grip tracks and shorter links tend to work better on medium-grip loose tracks.

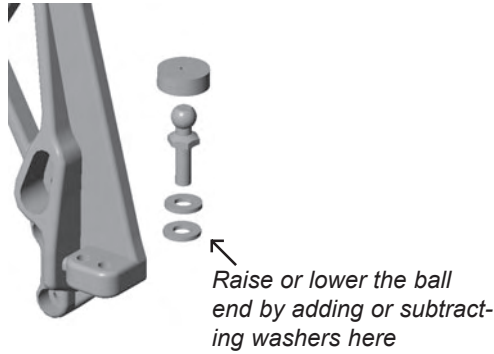

### STEERING BLOCKS

The included trailing steering blocks (#9581) should be used in most cases. The Team especially recommends the trailing blocks on high-grip or “blue-groove”.

Changing to the optional inline steering blocks (#9577) will give the car an overall aggressive feeling. Steering entering and exiting the corners is increased, but straight line stability is slightly reduced.

### CASTER

Caster describes the angle of the kingpin as it leans toward the rear of the vehicle. Positive caster means the kingpin leans rearward at the top.

The supplied 25° caster blocks (#9580) are recommended in most cases. For more corner entry steering and less exit steering, try the optional 30° blocks (#9593).

The optional 20° blocks (#9592) will give you more exit steering and less entry steering.

### CAMBER

Camber describes the angle at which the tire and wheel rides when looked at from the front. Negative camber means that the tire leans inward at the top.

A good starting camber setting is  $-1^\circ$ . Use the included #1719 camber gauge to set your camber as shown. Positive camber, where the top of the tire is leaning out, is not recommended.

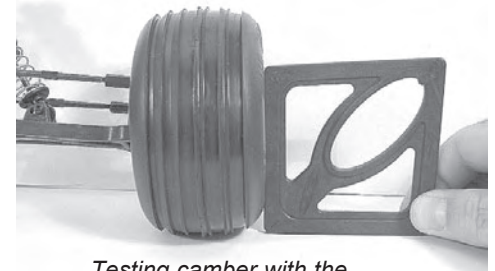

*Testing camber with the camber gauge*

### FRONT TOE-IN

Toe-in describes the angle of the front tires when viewed from the top. With toe-in, the front of the tires point inward.

Zero degree toe-in (tires pointing straight forward) is the setting that should be used in almost all track conditions. Occasionally you can increase turn in by adding a little toe-out (front of tires point slightly out). Front toe-in is not a typical tuning adjustment used by the Team.

### FRONT RIDE HEIGHT

Ride height is the distance from the ground to the bottom of the chassis.

The standard front ride height setting is with the front arms level (referred to as “arms level”). Check the ride height by lifting up the entire car about 8-12 inches off the bench and drop it. After the suspension “settles” into place, add or remove pre-load clips so that the left & right arms appear to be flat as seen in the following picture.

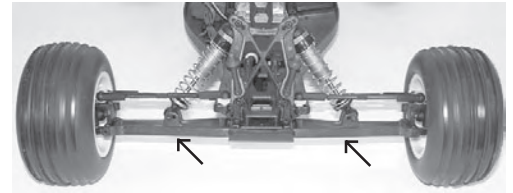

*Front arms should be in a straight line when ride height is set as “arms level”*

### ANTI-SQUAT

Anti-squat denotes the angle of the rear arms relative to the ground. Zero anti-squat means that the rear arms are flat, parallel with the ground. The kit setting is  $2^\circ$ , and can be adjusted by installing or removing the included

shims underneath the arm mount.

The shim with 2 tabs is for  $2^\circ$  and the shim with 1 tab is for  $1^\circ$ . You can use any combination of shims to get 0, 1, 2, or  $3^\circ$  anti-squat. Adding anti-squat tends to make the car “rotate” more in corners, but doesn’t handle as well through the bumps.



*Upper shim (with one tab),  $1^\circ$   
Lower shim (with two tabs),  $2^\circ$*

### REAR CAMBER LINK

Changing the length of the camber link is considered a bigger step than adjusting the ball end height on the rear chassis brace. Shortening the camber link (or lowering the ball end) will give the rear end less roll and the car will tend to accelerate or “square up” better. Lengthening the camber link (or raising the ball end) will give the rear more roll and more cornering grip. Longer camber links are typically used on high grip tracks, while shorter links tend to work better on med-grip loose tracks. The kit setting is the best compromise of cornering grip and acceleration.

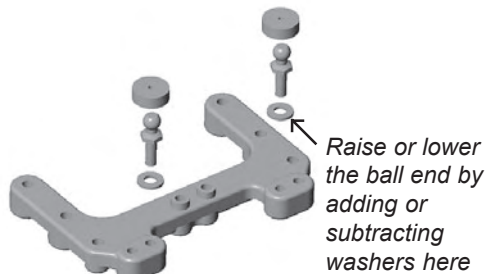

### REAR CAMBER

Camber describes the angle at which the tire and wheel rides when looked at from the back. Negative camber means that the tire leans inward at the top.

A good starting camber setting is  $-1^\circ$ . Use the included #1719 camber gauge to set your camber (shown above). Adding a small amount of positive camber, where the top of the tire is leaning out, will tend to improve straight-line acceleration on loose tracks.

## WHEELBASE ADJUSTMENT

You have three options for rear hub spacing, Forward, Middle, & Back. The kit setting provides the most rear traction, and will be used most often. For improved handling in bumps or rhythm sections, try moving the hubs to the Middle or Back position. This can also make the car handle better in 180° turns.

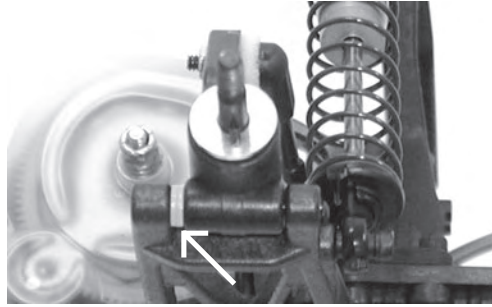

*Spacers to the rear will place hubs forward, shortening the wheelbase*

## ANTI-ROLL BAR

The optional #9635 B4/T4 rear anti-roll bar kit (also called the “swaybar”) allows you to add roll resistance to the rear end with minimal effect on handling over bumps and jumps. It is an especially helpful tuning item on high-grip tracks (try the gold bar). The silver and black anti-roll bars are typically used on medium-grip loose tracks.

## REAR RIDE HEIGHT

Ride height is the distance from the ground to the bottom of the chassis.

The rear ride height setting you should use most often is with the outdrive, driveshaft, and axles all on the same imaginary horizontal line (referred to as “bones level”). Check the ride height by lifting up the entire car about 8-12 inches off the bench and dropping it. After the suspension “settles” into place, add or remove pre-load clips so that the left & right driveshafts appear to be flat as seen in the following picture.

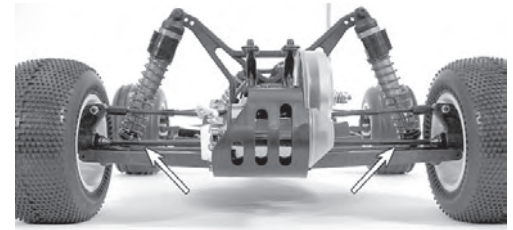

*Dogbones should be in a straight line when ride height is set as “dogbones level”*

## BATTERY PLACEMENT

This is one of the best adjustments on the car, and it can have the biggest effect on handling. Most of the time, moving the battery pack back will yield more rear traction and decrease steering. Conversely, moving the battery pack forward will yield less rear traction and increase steering. But in some cases on extremely high grip or extremely low grip tracks, moving the pack forward will make the car feel more balanced and actually improve rear grip.

FRONT

REAR

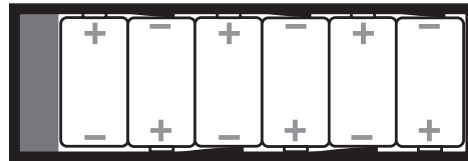

*Spacers to the front will place batteries to the rear*

FRONT

REAR

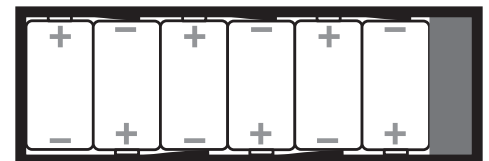

*Spacers to the rear will place batteries to the front*

## SETUP SHEETS

The best way to get your car handling right is to go to our website, [www.rc10.com](http://www.rc10.com), and click on the links for setup sheets. Our Team Drivers help develop these setups at National events.

Also, most drivers have a “base” setup that they use as a starting point for every event. Try running some of these base setups or look for

track conditions and tires that are similar to your local track and mimic that setup.

Remember, each adjustment has a purpose, so copy everything from the setup sheet and then make adjustments based on the recommendations in here.

## TEAM ASSOCIATED ONLINE

Get online help, tips, and new product information for your kit through Team Associated’s web site, [www.TeamAssociated.com](http://www.TeamAssociated.com).

**Kit Tips & Help.** Have questions? Look here first!

**Parts Catalogs.** Your printed catalog is probably already out of date! Find the most up-to-date listing of parts for your kit.

**Contact Associated.** Our expert staff answers your toughest questions about Associated, Reedy, and LRP products.

**Racer’s Spotlight.** Racers proudly show off their favorite kits. Get your painting ideas here!

**Setup Sheets.** Where racers find blank and standard setups for different track conditions. What are the winning racers using?

**New Products.** Learn of new kits and parts before they are announced anywhere else.

**Team Associated Insider’s Newsletter.** Sign up for it if you want the latest Team Associated news delivered right to your e-mail box.

**Hobby Shop and Track Directory.** Locate shops carrying spare parts and find tracks where you may race your car.



**SETUP SHEET for the Team Associated RC10T4**

Driver \_\_\_\_\_  
 Track / City \_\_\_\_\_  
 Event \_\_\_\_\_ Date \_\_\_\_\_

**FRONT SHOCK MOUNTING & CAMBER LINK**

RIDE HEIGHT \_\_\_\_\_

CAMBER \_\_\_\_\_ °

**REAR SHOCK MOUNTING & CAMBER LINK**

RIDE HEIGHT \_\_\_\_\_

CAMBER \_\_\_\_\_ °

TOE-IN (+) / OUT (-) \_\_\_\_\_ °

BUMP STEER SPACER \_\_\_\_\_

AXLE HEIGHT  up  middle  down

CASTER  20°  25°  30°

STEERING BLOCK  trailing  inline

ANTI-SQUAT  0°  1°  2°  3°

WHEELBASE  long  medium  short

ANTI-ROLL BAR  none  black (soft)  silver (med)  gold (heavy)

**FRONT SHOCKS** OIL \_\_\_\_\_ wt

SPRING (color) \_\_\_\_\_ PISTON # \_\_\_\_\_

SHAFT  unobtainium  STD # LIMITERS \_\_\_\_\_

**REAR SHOCKS** OIL \_\_\_\_\_ wt

SPRING (color) \_\_\_\_\_ PISTON # \_\_\_\_\_

SHAFT  unobtainium  STD # LIMITERS \_\_\_\_\_

**FRONT TIRES & WHEELS**

FRONT TIRES \_\_\_\_\_

INSERTS \_\_\_\_\_ WHEELS \_\_\_\_\_

TRACTION COMPOUND \_\_\_\_\_

**REAR TIRES & WHEELS**

REAR TIRES \_\_\_\_\_

INSERTS \_\_\_\_\_ WHEELS \_\_\_\_\_

RADIO/BATTERIES	MOTOR	OTHER
RADIO _____ SERVO _____	MOTOR & WIND _____	BODY _____
ESC _____	BRUSHES _____	SPOILER _____
DRAG BRAKE _____ INIT BRAKE _____	SPRING _____	CHASSIS _____
BATTERIES _____	PINION / SPUR _____ / _____	
BATTERY PLACEMENT: spacers in front _____ spacers in rear _____		

**CONDITIONS**

smooth  sandy  
 bumpy  soft dirt  
 low traction  grass  
 med traction  blue groove  
 high traction  clay

wet  dusty  
 dry  other

**COMMENTS**

NOTES \_\_\_\_\_  
 \_\_\_\_\_  
 \_\_\_\_\_  
 \_\_\_\_\_

**WE RECOMMEND REEDY POWER FOR THE T4!**

# REEDY MOTOR

## **Reedy Spec 19 "Quad-Mag" motor!**

Hot on the heels of Reedy's new "Krypton" (Kr) Modified comes the Reedy 19-turn "Spec" class motor. This all-new motor is designed specifically for all classes of electric spec-class racing -- off road, on road, oval, and touring car -- and utilizes the Kr's trend-setting four-magnet can, standard-sized commutator, laydown brushes, black can, and a distinctive bright orange endbell. The Spec 19 is offered with a machine-wound armature, with separate armatures also available.



# REEDY CHARGER Quasar

## **AC/DC Chargers for NiCD and NiMH batteries!**

- 120 AC, 15V DC switching power supply. Pro version is also available in 240V.
- Pro version has discharge and cycle modes.



# AC/DC Ni<sup>CD</sup> Ni<sup>MH</sup>

## **Cycled, matched, and voltage-treated for maximum on-track performance!**

- Reedy/Yokomo Gold Peak 3300s.
- Longer run times than most other 3300 NiMH cells.
- 4 and 6 cell versions available.

# REEDY

# BATTERIES

## **Assembled 3000 cells in convenient stick pack format!**

- Cycled, matched, and voltage treated.
- Clear tubes allow you to see the matching info in the package.
- Available in Sanyo and Panasonic configurations.



**FOR PRICING AND AVAILABILITY, GO TO: [www.RC10.com](http://www.RC10.com) and click on REEDY**