

TEAM ASSOCIATED

STARTER BOX #1750

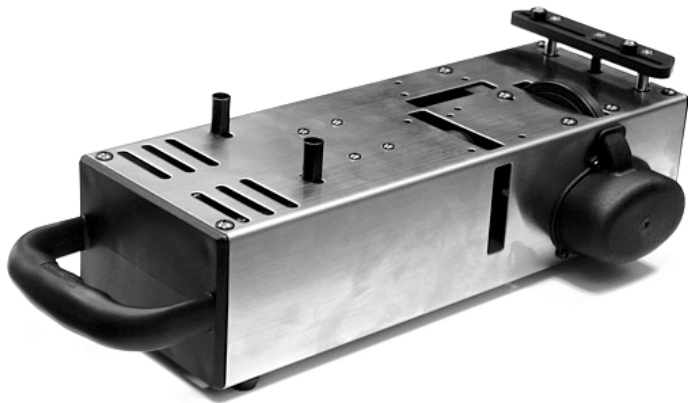

SPECIFICATIONS

| | |
|--------------|--|
| Power source | 14.4V DC (two 7.2V stick battery packs) or (not included) 12V DC (gel cell, car battery, power supply, etc.) |
| Motor | 775-size 10V - 14V DC electric |
| Pulley ratio | 4.307:1 (13T pinion pulley / 56T spur pulley) |
| Length | 13.38" (340mm) without handle |
| Width | 4.72" (120mm) |
| Weight | 64 zo. (1800g) without batteries |
| Post height | .79" (20mm) front, .24" (6mm) rear |

FEATURES

- Fits RC10GT and Nitro TC3
- Compact, lightweight design
- Brushed stainless steel case
- Oversized ergonomic handle
- Tough, nylon composite parts
- Top/single tool adjustable posts
- Durable rubber flywheel
- Selectable flywheel orientation (1:8, 1:10, on or off road)
- Adjustable flywheel engagement point
- Efficient belt-drive system
- Single, large, heavy-duty 775 size motor
- High torque pulley/belt reduction system
- Accepts twin 7.2V packs or 12V DC power
- Factory assembled,



1

STARTER BOX SETUP

1 Identify the car's flywheel orientation. The starter box currently is built to start an engine which has its crankshaft lined up with the chassis.

For cars with the crankshaft aimed perpendicular to the chassis centerline, remount it 90 degrees according to instructions on the back.

2 Line up the engine flywheel with the starter box's flywheel. The chassis needs to line up where the apex of the engine flywheel meets the starter box flywheel in an up and down motion.

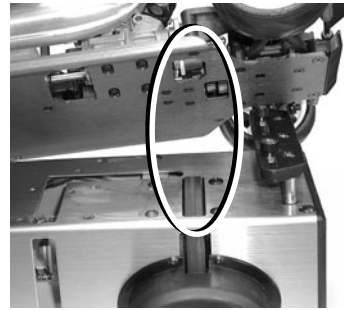

Set the chassis down so the flywheels line up

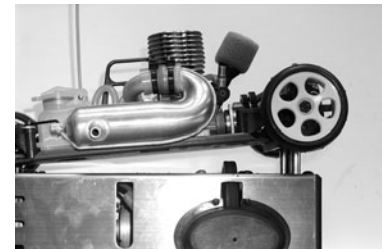
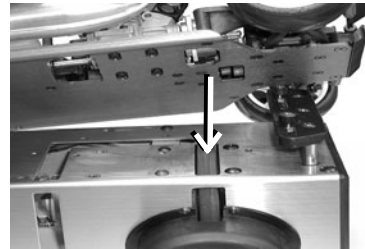

3 With the chassis lined up like step #2, adjust the spring-loaded platform to support the rear of the chassis. The spring-loaded platform can be flipped to accommodate the length of the chassis. If needed, disassemble, turn the platform 180 degrees, and reassemble.



Spring-loaded platform reverses direction to accommodate different chassis lengths



2

4 With chassis lined up like step #2, unscrew the front posts and move them so that they are located behind the front lower suspension arms. You may slide them sideways or move them to the next slot.

Then slide the posts inward so that they pinch the chassis loosely and tighten them down.

Move the front posts to behind the suspension arms and against the chassis

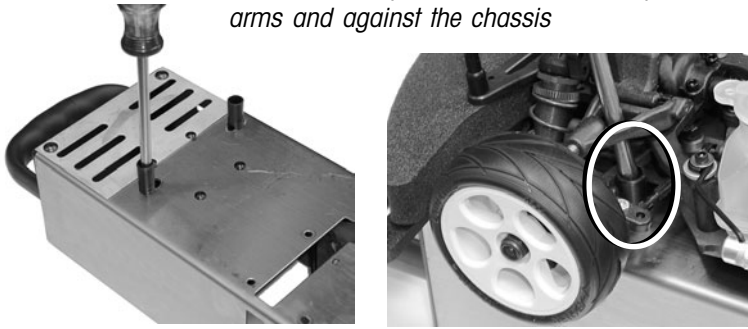

5 With chassis lined up like step #2 and front posts already set, unscrew and slide the rear posts located on the rear platform so that they are pinching the rear of the chassis loosely.

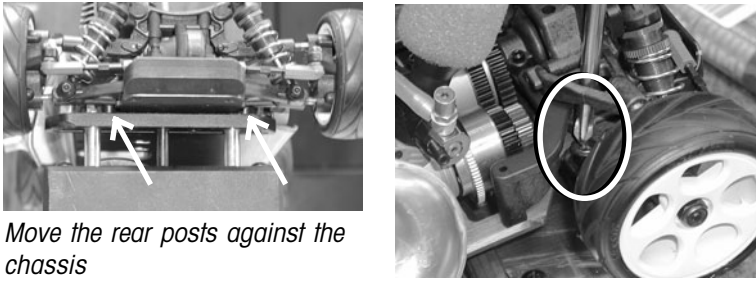

Move the rear posts against the chassis

6 Here are two ways to hook up the power:

Clip the female end of the three point adapter into the starter box. Then clip the remaining two male ends of the adapter into the two 7.2V stick battery packs (not included). Then place the battery packs into the battery holder and flip down the restraining clip.

OR clip the female end of the adapter with alligator clips into the starter box. Then clip the alligator clips of the power cord to the 12V DC source. Make sure the polarity of the connection is correct: red to positive and black to negative.

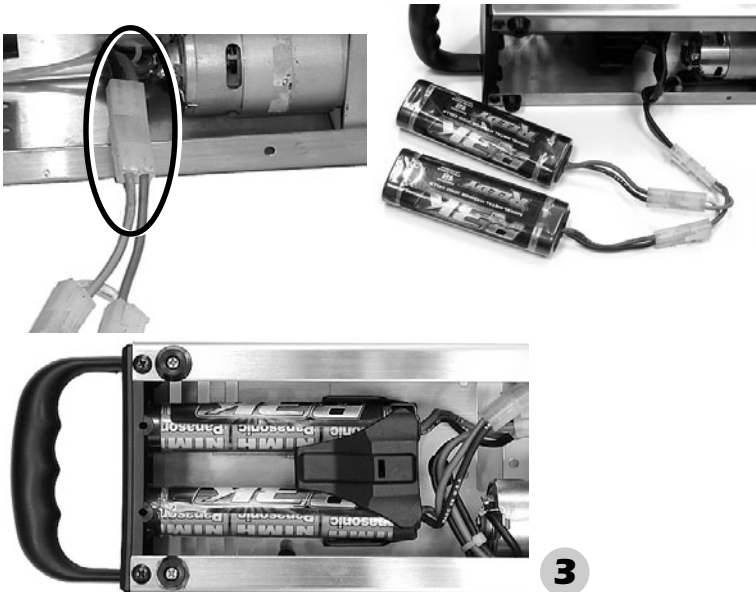

3

7 Now when you press on the spring-loaded platform, the flywheel should spin clockwise (looking from spring-loaded platform to fall front posts).

If it spins counter-clockwise:

- The polarity of the connection is likely to be wrong. Double-check the plugs or power cord.

Reconnect red to positive and black to negative.

If it does not spin:

- The 7.2V battery packs or the 12V DC source is bad, dead, or the adapter's power cord is not making a solid connection. Check them with a voltmeter.

- The spring-loaded switch is not making a connection. Check the switch, and turn the engagement adjustment screw clockwise so that it engages sooner.

- The pulley belt is too tight. Loosen the two screws which are holding the motor, adjust the pulley tension (1mm in from the outermost limit where the belt will allow the pulley to separate), and tighten the two screws again.

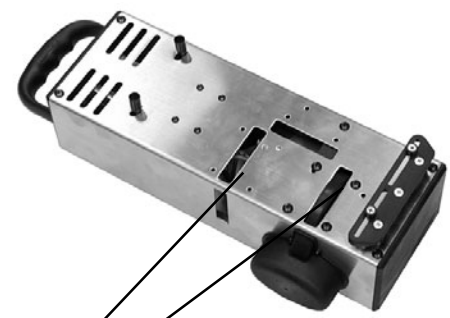

*In this slot it spins clockwise.
In this slot it spins counter-clockwise.*

8 The starter box flywheel should start spinning right before it contacts the engine flywheel. To adjust when the flywheel starts to spin, position the car on top of the starter box aligned with the posts so that the flywheels line up. Press down slowly on the car until the starter box flywheel starts spinning.

If it starts to spin too early, turn the engagement screw clockwise. If the engine and starter box flywheels contact before it starts to spin, turn the engagement screw counterclockwise.

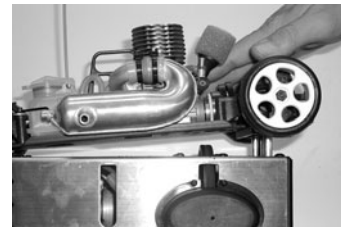

Flywheel stationary

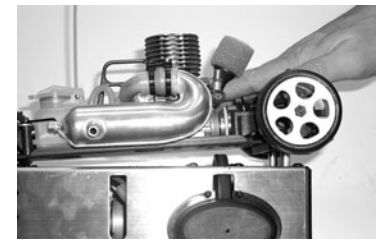

Flywheel spinning

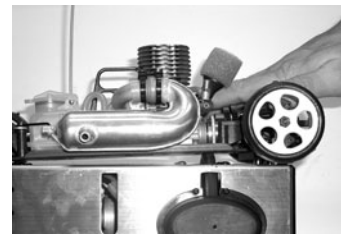

Flywheels engage

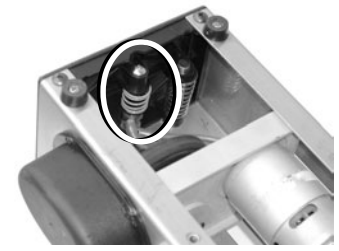

Turn the engagement screw to adjust when the flywheel starts spinning

4

OPERATING INSTRUCTIONS

1 Place the starter box on the ground or a flat, solid, and stable surface like a table.

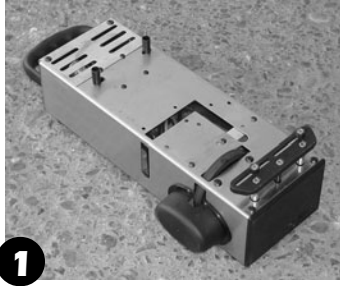

2 Properly place the car on top of the starter box within the preset posts.

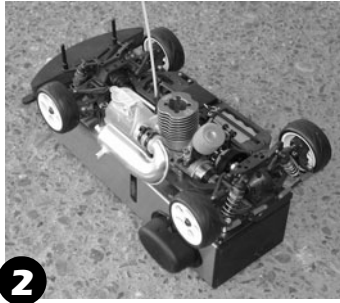

3 (If the engine had already been started moments before, skip this step.) If the engine has not been started, press down on the car (with the carburetor fully open) to turn over the engine for a few seconds. Repeat until you see the fuel reaching the engine's carburetor.

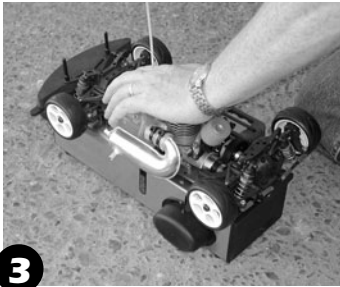

4 Make sure the radio is on and you have full control of the carburetor/throttle.

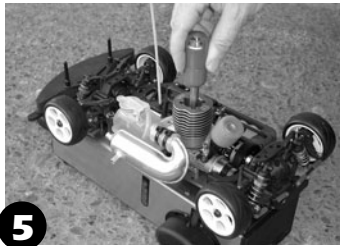

5 Place the glow igniter on the engine.



6 Press down on the car for a few seconds. Release if the engine starts. When the flywheels engage, keep the car down so that the flywheels keep contact, but do not press down further.

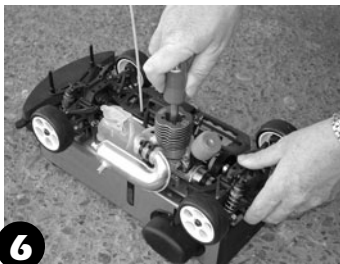

7 Repeat if the engine does not start and consult the owner's manual for this engine.



8 After the engine has started, remove the glow igniter from the engine and the car from the starter box.

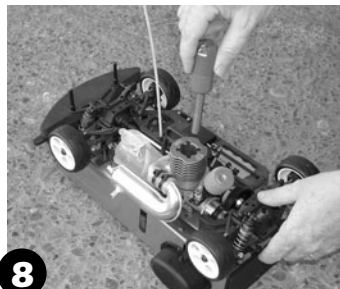

5

TURNING THE WHEEL 90 DEGREES

1 Disconnect the batteries. Remove the motor bracket, motor bulkhead and platform screws. Remove the case end screws, top and bottom.



2 Remove the case end and starter bulkhead.

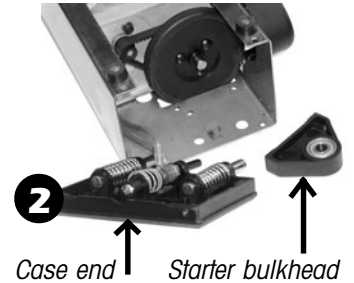

3 Remove the three screws from the flywheel. Remove the flywheel and belt. Turn the motor bracket slightly and slide it out.

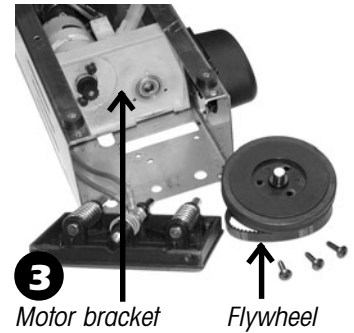

4 Remove the two screws holding the motor to the bracket, turn the bracket around, and mount the motor back on. Remove the screws holding the bearing cap and mount it on the other side, as shown.

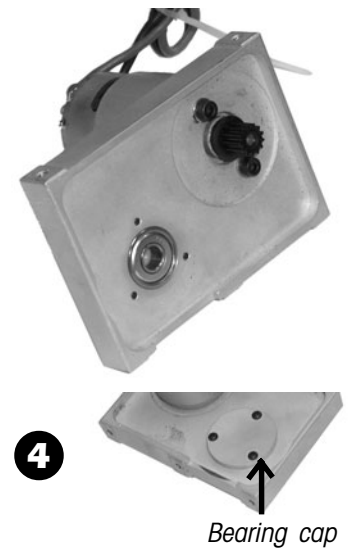

5 Slide the motor bracket into the unit and do the following.

6 Place the flywheel/belt into position and mount it.

7 Mount the motor bracket to the starter box.

8 Mount the starter bulkhead to the starter box.

9 Push the case end into position and mount the case end and platform.

10 Connect the batteries.

6

ASSEMBLY DIAGRAM

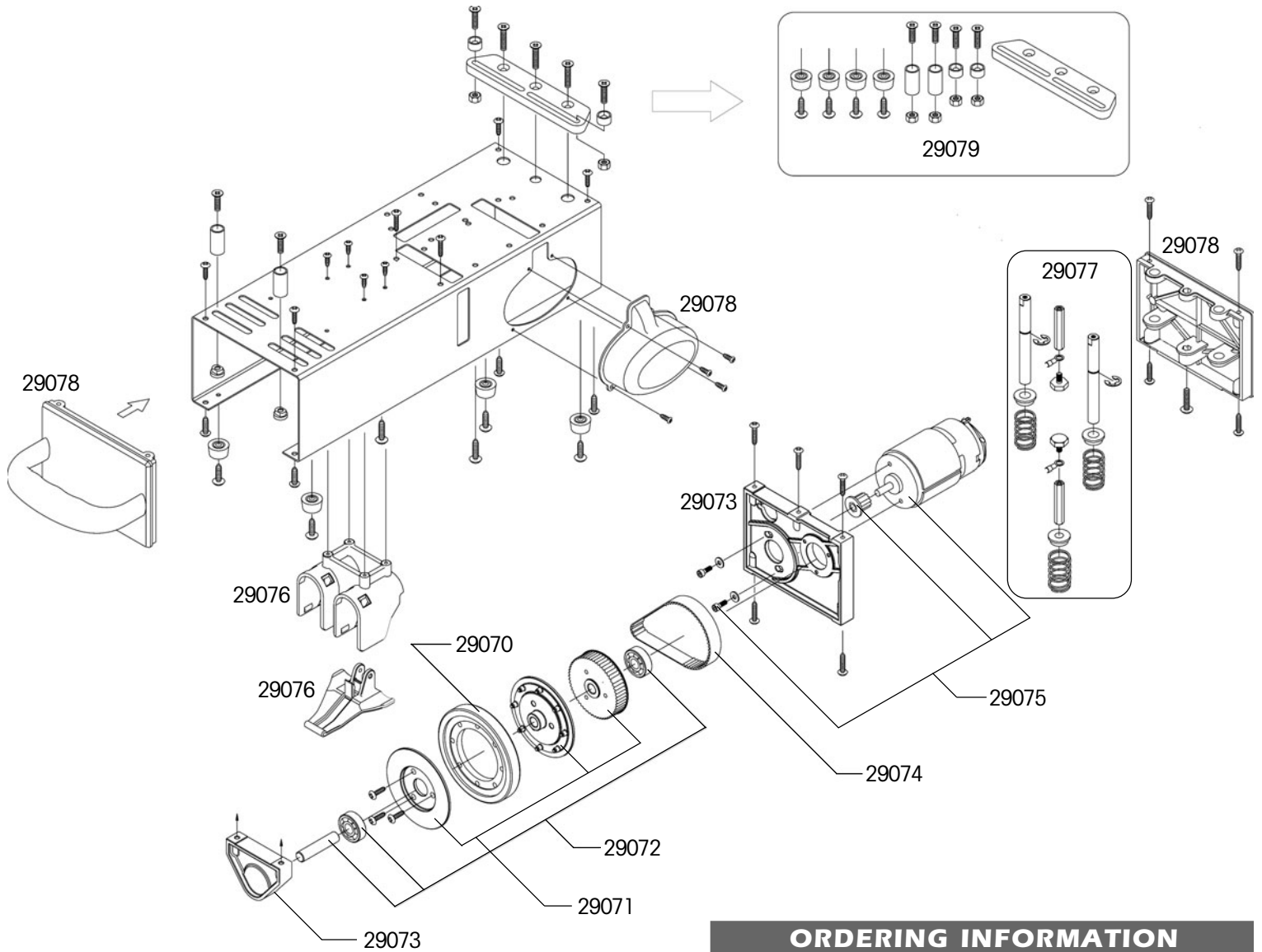

ORDERING INFORMATION

| Part no. | Description | Retail price |
|----------|-----------------------------|--------------|
| 1750 | Team Associated Starter Box | 99.99 |
| 29070 | Starter Flywheel | 5.00 |
| 29071 | Spur Pulley Set | 8.00 |
| 29072 | Bearing/Axle Set | 7.00 |
| 29073 | Starter Bulkhead | 6.00 |
| 29074 | Drive Belt | 13.00 |
| 29075 | Starter Motor | 40.00 |
| 29076 | Battery Holder | 5.00 |
| 29077 | Post, Spring, Switch Set | 5.00 |
| 29078 | Case Ends/Cap | CALL |
| 29079 | Feet, Post, Platform Set | 4.00 |

TEAM ASSOCIATED
3585 Cadillac Ave.
Costa Mesa, CA 92626



phone: (714) 850-9342
fax: (714) 850-1744
web site: <http://www.teamassociated.com>