

ASSOCIATED NURF WING

NOTE: This wing is highly necessary for oval racing. Bolt each wing just forward of the rear tires where shown in Fig. 1 as follows:

STEP 1 Place the wing hole over rear body mount hole as shown on top of chassis. Position body mount on top of the nurf wing and bolt it down by the screw.

STEP 2 Drill a .110" hole into the chassis through the second hole of the nurf wing.

STEP 3 Slide the 4-40 x 1/2 screw up through the bottom and screw down the locknut on top of the wing.

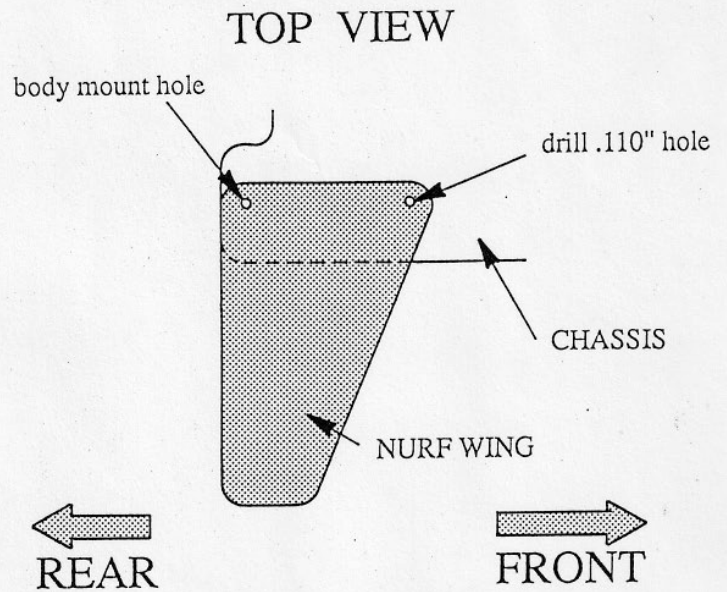

Fig. 1