

step 4

- 1 Holding the shock upright, fill with oil to the top of the body.

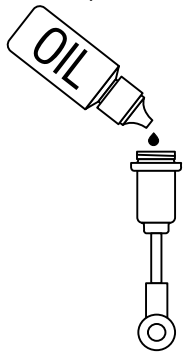

- 2 Slowly move the shaft up and down several times to allow air bubbles to escape to the top.

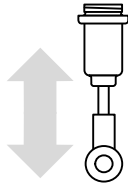

- 3 Refill with oil to the top of the body.



- 4 Push the shaft up until the piston is level with the top of the body. The oil will bulge up above the shock body.

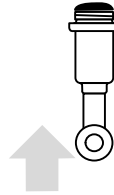

- 5 Fill The #6428 shock cap about halfway with oil and install onto the body. Try to retain as much oil as possible during assembly. The shaft will extend out as you tighten the cap down.

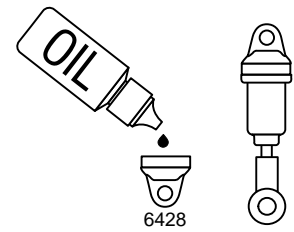

DISASSEMBLY

- 1 To take out the VC foam/bobbin, unscrew the ball cup and shock cap, and push the shock shaft out.
- 2 Push your Allen wrench tip into the shock bottom and push the bobbin out, as shown. The O-rings should just fall out by themselves.

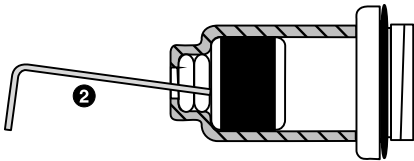

DS Qualifier SUPPLEMENTARY SHEET

The following steps replace steps 90-103 on pages 27-30.

REMOVE THESE PARTS

1:1 = actual size part

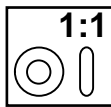

5407, qty 8
red O-ring

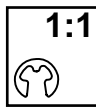

6299, qty 8
E-clip



7217, qty 4
pivot ball
plastic



8456, qty 4
VC foam

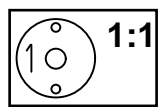

6465, qty 4
shock piston #1

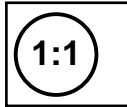

6469, qty 4
large O-ring

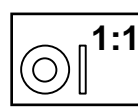

6466, qty 4
1/32" spacer

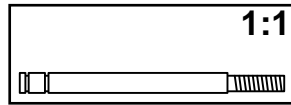

8844, qty 4
shock shaft



8456, qty 4
VC bobbin

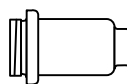

8458, qty 4
macro shock
body



6428, qty 4
shock cap



7217, qty 4
eyelet
nylon



5421, qty 1
40 wt
silicone oil

TOOLS USED

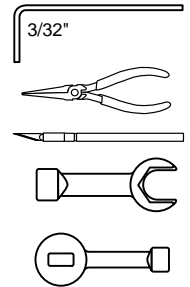

step 1

TRIM SHOCK PISTON

- 1 Burrs interfere with smooth shock action within the shock body. To remove from tree without creating burrs, twist up, not down. Remove one #1 shock piston.
- 2 Remove remaining burrs carefully with hobby knife.

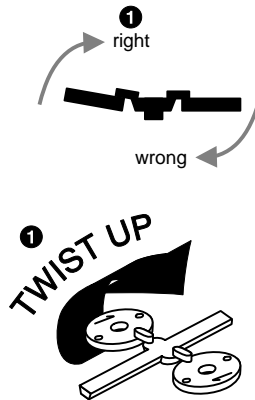
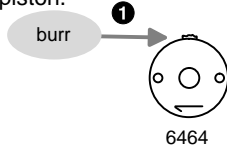

step 2

VC FOAM AND PISTON

Soak the #8456 VC foam with #5422 shock oil and install it onto the #8456 VC bobbin.

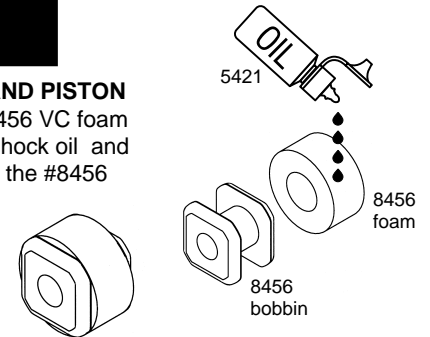

step 3

- 1 Install the #6469 O-ring over the threads of the #8458 shock body.
- 2 Install a #6299 E-clip on either side of a #6465 (#1) piston.
- 3 Slide one #6466 1/32" spacer onto the shock shaft.
- 4 Next install the assembled VC foam/bobbin over the shaft followed by two #5407 red O-rings. Place a couple of drops of oil on the O-ring. Insert the assembly into the shock body and pull the shaft through firmly to seat the VC bobbin at the base of the shock bore.
- 5 Push the #7217 pivot ball and eyelet together, then screw the eyelet onto the end of the shock shaft.

